

MAHA BODHI SCHOOL
2024 SCIENCE REVIEW 2
PRIMARY FIVE

Name : _____ ()

Date : 21 August 2024

Class : Primary 5 _____

Duration : 50 min

Marks:

/ 30

Parent's signature : _____

Section A : [8 x 2 marks = 16 marks]

For each question from 1 to 8, four options are given. One of them is the correct answer. Make your choice (1, 2, 3 or 4). **Write your answer in the bracket.**

1. The diagram below shows how water changes from one state to another during processes A, B, C and D.

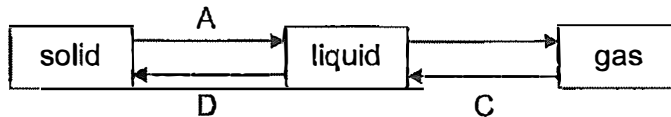

Which of the following statements is correct?

- (1) Process C occurs at a specific temperature.
- (2) Water gains heat during processes C and D.
- (3) There can only be one process to represent B.
- (4) Processes A and D occur at the same temperature.

()

Marks :

/ 2

2. The diagram below shows the human respiratory system.

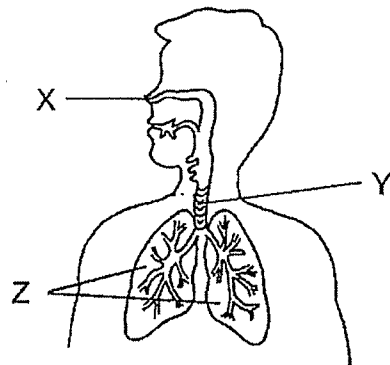

Which of the following statements about this system are correct?

- A. Air and food pass through Part Y.
- B. Exchange of gases takes place in part Z.
- C. Air can only enter the human body through part X.
- D. Dust is removed from the air we breathe in at part X.

- (1) A and C only
- (2) B and D only
- (3) A, B and D only
- (4) A, B, C and D

()

Marks :

12

3. The stem of a green plant was cut at two parts, X and Y, as shown below. The plant was left under the sun for one week. The soil was kept moist.

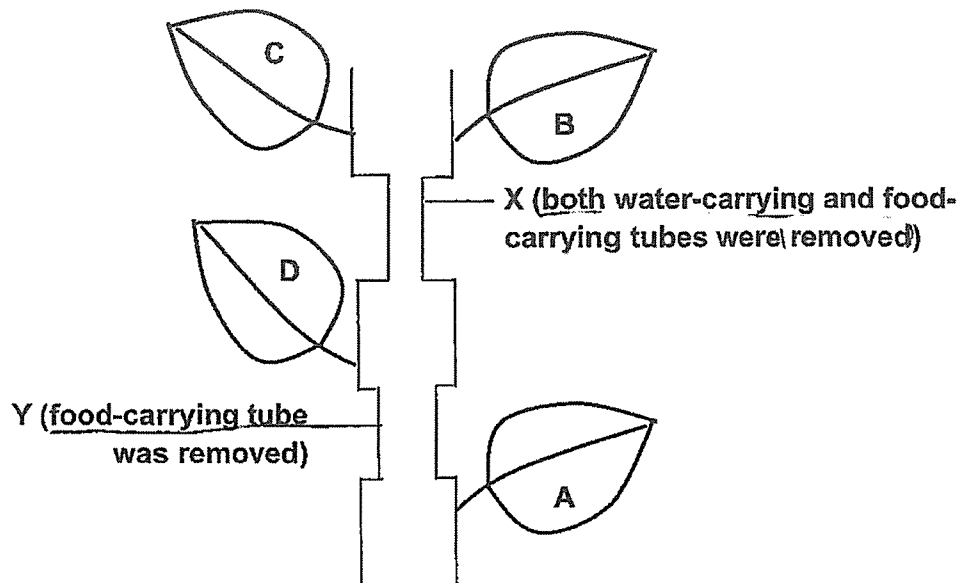

Which of the leaves would start to dry up after a week?

- (1) A and D only
 (2) B and C only
 (3) B, C and D only
 (4) A, B, C and D

()

4. The table below shows the melting and boiling points of two substances, K and L.

Substance	Melting point (°C)	Boiling point (°C)
K	52	300
L	44	280

Which of the following shows the correct state of K and L at 285°C?

	K	L
(1)	liquid	liquid
(2)	liquid	gas
(3)	gas	liquid
(4)	gas	gas

()

Marks :

/ 4

5. Siti prepared four set-ups W, X, Y and Z using identical containers of water. The table below shows the different conditions at the start of each experiment.

	Set-up			
	W	X	Y	Z
Room temperature (°C)	25	16	16	16
Exposed surface area of water (cm ²)	40	150	40	40
Volume of water (cm ³)	300	300	200	300

Siti wanted to find out how the volume of water was affected by the temperature.

Which of the following two set-ups should Siti compare?

- (1) W and X
- (2) W and Y
- (3) W and Z
- (4) X and Z

()

6. Five people were trapped in a locked room without any windows.

Which of the following shows the changes in their breathing rate and the amount of gases breathed out by them?

	Breathing rate	Amount of gases/breathed out		
		carbon dioxide	oxygen	water vapour
(1)	decrease	decrease	increase	increase
(2)	decrease	increase	decrease	increase
(3)	increase	decrease	increase	decrease
(4)	increase	increase	decrease	increase

()

Marks : / 4

7. Study the diagrams below.

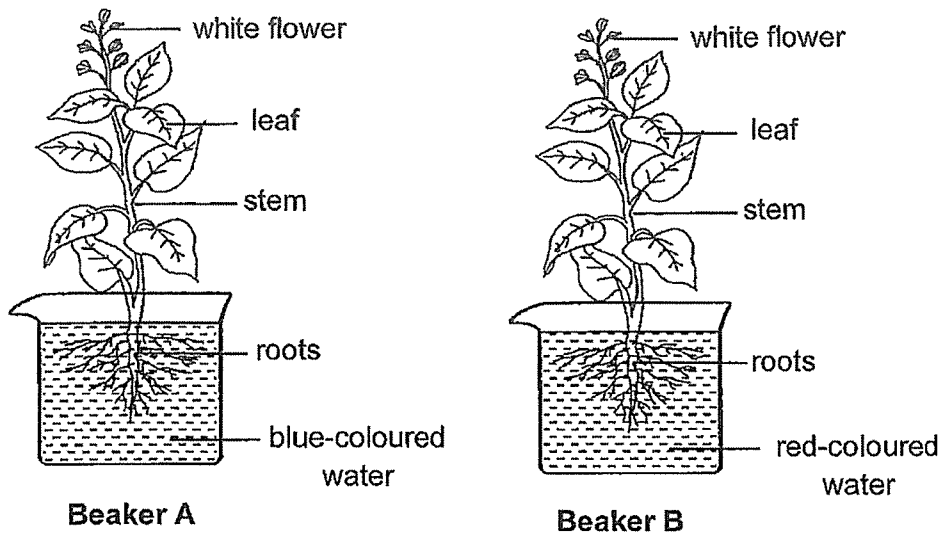

Two similar plants with white flower were placed in two identical beakers. Beaker A was filled with blue water while Beaker B was filled with red water. After one day, the flowers of the plant in Beaker A became blue and the flowers in Beaker B became red.

What is the conclusion that can be drawn from the experiment?

- (1) Plants need water to stay alive.
- (2) The leaves transported the coloured water to the flowers.
- (3) The food-carrying tubes carried the water from the leaves to the flowers.
- (4) The water-carrying tubes carried the water from the roots to the flowers.

()

Marks :

/ 2

8. The diagram below shows how food and water are being transported to and from the different parts (A, B and C) of a plant.

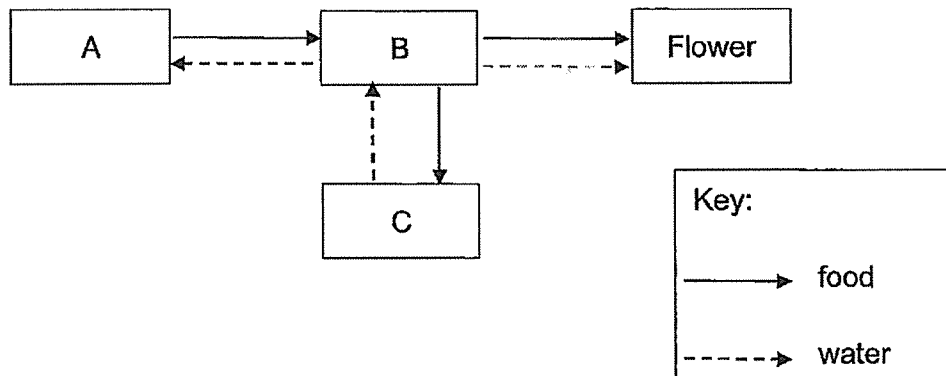

Which of the following represent parts A, B and C?

	A	B	C
(1)	leaves	stem	roots
(2)	roots	stem	leaves
(3)	leaves	roots	stem
(4)	stem	leaves	roots

()

Marks : / 2

SECTION B : [14 marks]

For questions 9 to 12, write your answers in this booklet.

The number of marks available is shown in the brackets [] at the end of each question or part-question.

9. Meifen put a block of butter into a container. After leaving the container on the kitchen table for a few hours, the butter turned into oil as shown below.

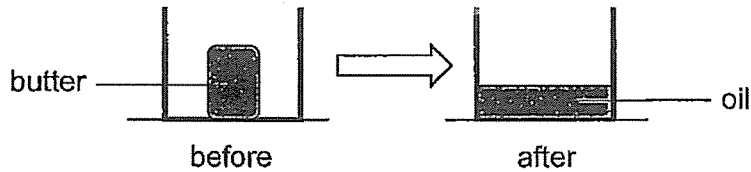

- (a) Name the process that caused the butter to turn into oil. [1]

- (b) What would Meifen observe about the temperature of the butter during the process mentioned in (a)? [1]

Meifen covered a pot of water with oil as shown below.

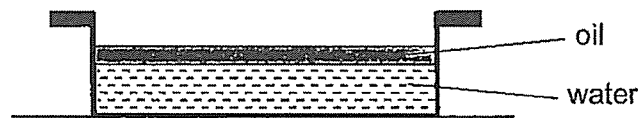

She kept the pot in a refrigerator at a temperature of 5°C. After some time, the oil froze on top of the water.

- (c) What can Meifen tell about the freezing point of oil? [1]

Marks:

/ 3

11. A farmer removed the food-carrying tubes from one part of the stem of a plant as shown below.

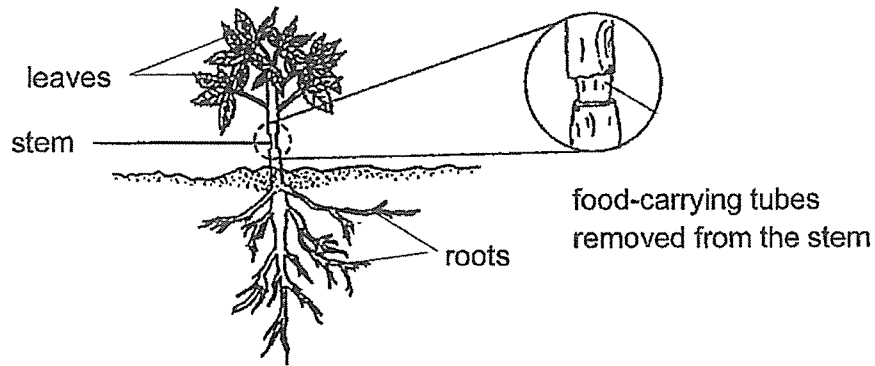

- (a) State the function of the food-carrying tubes. [1]

- (b) The farmer observed that the leaves of the plant did not dry up after a few weeks. Explain his observation. [2]

Marks:

/ 3

12. Leaves have tiny openings on their surfaces. Water is lost through these tiny openings in the form of water vapour.

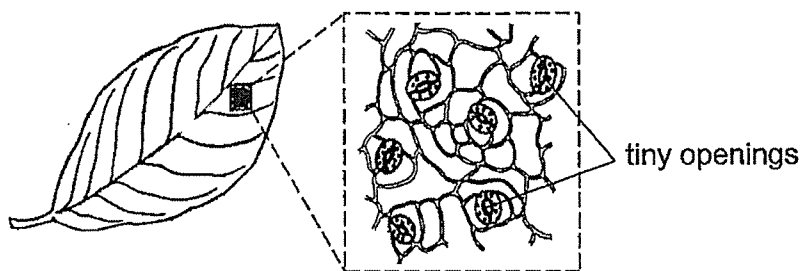

magnified view of an area of a leaf

- (a) What is another function of these tiny openings on the surfaces of leaves? [1]

- (b) An experiment was set up using four similar leaves E, F, G and H growing on the same plant X. These leaves had tiny openings on both their upper and lower surfaces.

Some surfaces of the leaves were coated with oil as shown in the table below.

Leaf	Coated with oil	
	Upper surface	Lower surface
E	no	yes
F	yes	yes
G	no	no
H	yes	no

Plant X was placed under bright sunlight for two hours, after which the mass of each leaf was measured. The results are shown in the graph below.

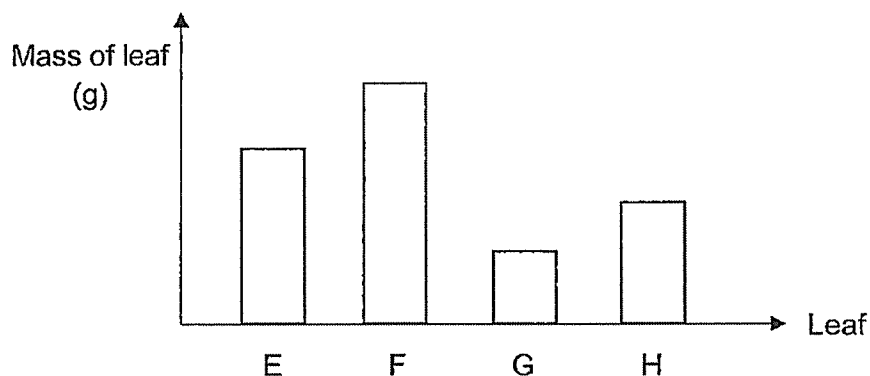

Marks: / 1

- (i) Based on the results of the experiment, arrange the leaves E, F, G and H according to the amount of water lost through the tiny openings. [1]

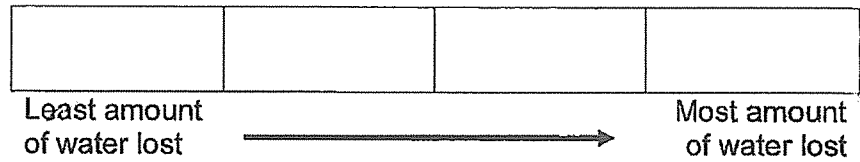

- (ii) Are there more tiny openings on the lower or upper surface of the leaves of the plant? Explain your answer based on the results of the experiment. [1]

- (c) The diagram below shows the respiratory system of a fish.

The gills of the fish also perform the same function as the tiny openings in the leaves which you have stated in (a).

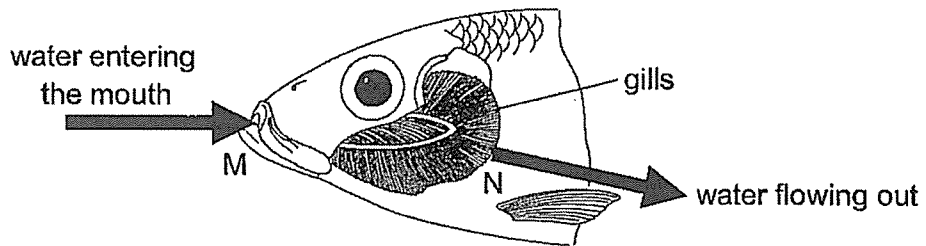

Show the differences between the water at M and N according to the amount of dissolved oxygen and carbon dioxide present by completing the table below with the words "more", "less" or "same". [1]

	Amount of dissolved oxygen	Amount of dissolved carbon dioxide
Water at M		
Water at N		

Marks: / 3

~ END OF PAPER ~

SCHOOL : MAHA BODHI SCHOOL
LEVEL : PRIMARY 5
SUBJECT : SCIENCE
TERM : 2024 WA2

Q1	Q2	Q3	Q4	Q5	Q6	Q7	Q8
4	2	2	2	3	4	4	1

Q9	<p>a) Melting</p> <p>b) The temperature stays the same.</p> <p>c) The freezing point of oil higher than the freezing point of water.</p>
Q10	<p>a) The water in the sea water gained heat from the surroundings and evaporated into water vapour. The water vapour touched the inner surface of the bottle. The water vapour lost heat and condensed into water droplets. The water droplets flowed downwards to be collected.</p> <p>b) The water had a larger exposed surface area and evaporated faster.</p> <p>c) The water vapour escaped. There is less water vapour to condensed.</p>
Q11	<p>a) The food-carrying tubes transport food made by the leaves to all parts of the plant.</p> <p>b) When the food-carrying tubes were removed, the water-carrying tubes were still present. So water absorbed by the roots could still be transported to the leaves through the water-carrying tubes.</p>
Q12	<p>a) Those tiny opening on the surface of the leaves help in gaseous exchange by taking in carbon dioxide and releasing oxygen through them.</p> <p>b) i) F, E, H, G ii) Lower. E lost less water than H.</p> <p>c) Water at M : more / less Water at N : less / more</p>