

**Anglo-Chinese School (Junior)**  
**P5 Science EYE Revision Paper 2**

Name: \_\_\_\_\_ ( ) P: 5. ( ) Date: \_\_\_\_\_

For each question from 1 to 28, four options are given. One of them is the correct answer. Make your choice (1, 2, 3 or 4). Shade your answer on the Optical Answer Sheet.

**(56 marks)**

1. Which statement is correct about yeast?

- (1) It is a type of bacteria.
- (2) It is used to make bread.
- (3) It can make its own food.
- (4) It is not a microorganism.

2. Study the flowchart.

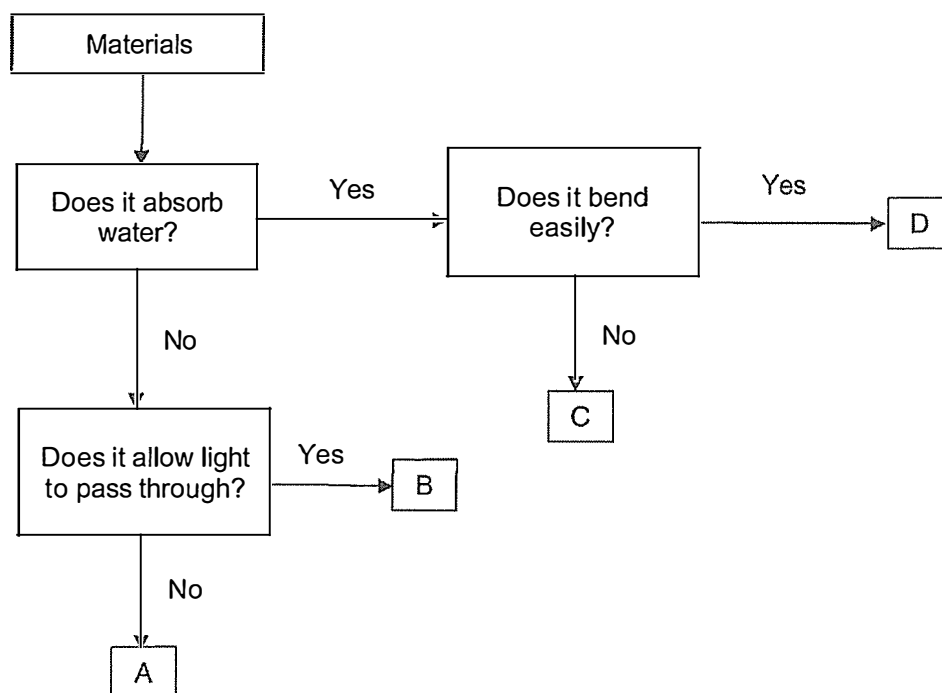

Which material, A, B, C or D, is most suitable to make part X of the sunglasses as shown?

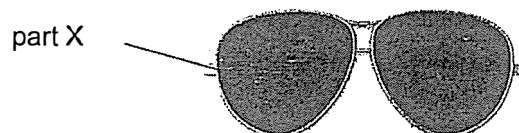

- (1) A
- (2) B
- (3) C
- (4) D

3. Study the life cycles of animals J and K.

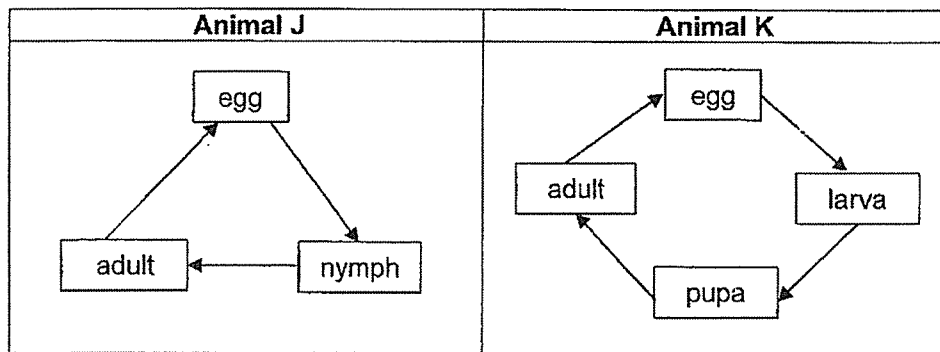

Which two statements are true?

- A The larva of animal K eats a lot.
- B Animal J could be a grasshopper.
- C Animal K's young resembles its adult.
- D Both life cycles of animals J and K begin with the egg stage.

- (1) A and B
- (2) A and D
- (3) B and C
- (4) C and D

4. Aneesa placed five identical green bean seeds each into four identical containers, A, B, C and D. She placed the containers at different locations as shown and watered the seeds daily for three days.

Container	Location
A	Garden
B	Freezer
C	Dark Cupboard
D	On the kitchen table

In which container(s) will the seeds germinate over the next few days?

- (1) B only
- (2) A and D only
- (3) B and C only
- (4) A, C and D only

5. The diagram shows the seed dispersal patterns of plants A, B and C.

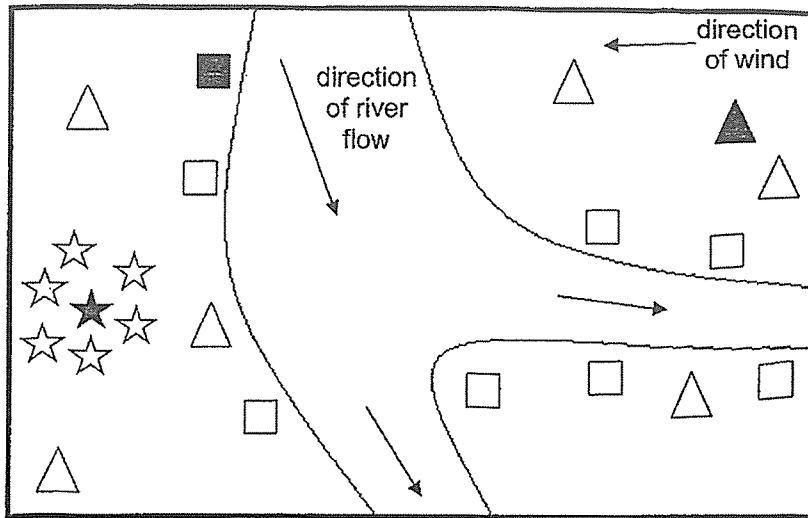

Key :

■ Parent plant A	□ Young plant of A
★ Parent plant B	☆ Young plant of B
▲ Parent plant C	△ Young plant of C

Which of the following characteristics do the fruits/seeds of plants A, B and C have?

	Plant A	Plant B	Plant C
(1)	pod	hooks	wing-like structure
(2)	fibrous husk	pod	hooks
(3)	hooks	wing-like structure	fibrous husk
(4)	wing-like structure	fibrous husk	pod

6. The diagram shows the cross-section of a flower and fruit from plant X.

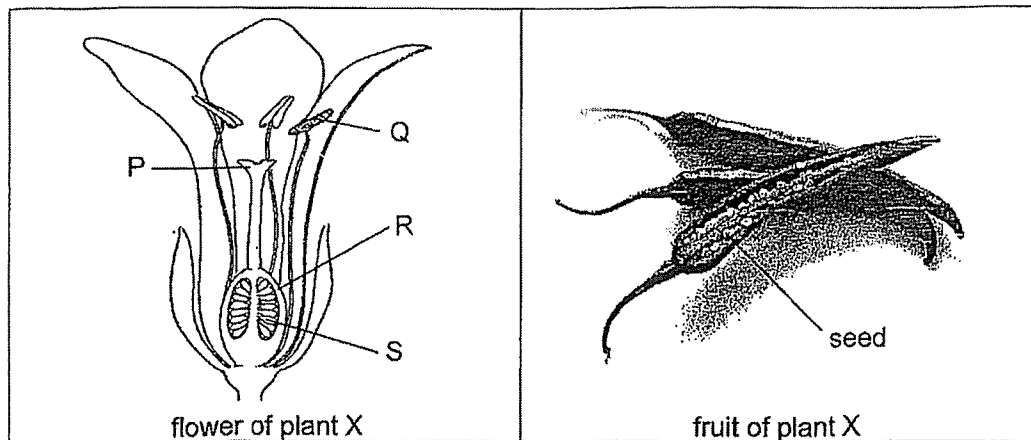

Which parts of the flower did the seed and fruit develop from?

	Seed	Fruit
(1)	P	Q
(2)	Q	P
(3)	R	S
(4)	S	R

7. The diagram shows the parts of the human female reproductive system. A cut was made at X.

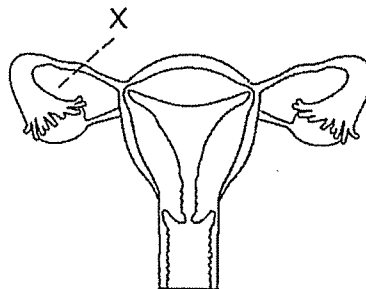

Which of the following statement(s) is/are true?



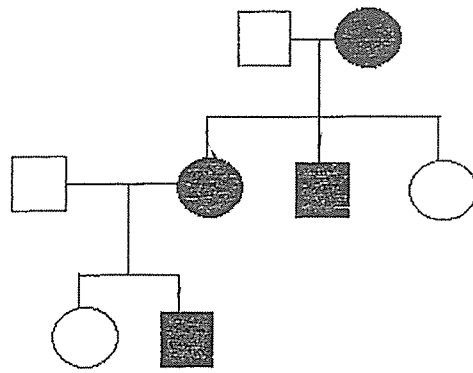

- A Eggs will not be released.
  - B Fertilization can take place.
  - C Sperms can enter the vagina.
  - D The foetus will not be able to develop.
- (1) D only  
 (2) B and C only  
 (3) C and D only  
 (4) A, B and C only

8. Study the family tree.



Xueling

Key :

	male with double eyelids
	male with single eyelid
	female with double eyelids
	female with single eyelids

Which statement about Xueling is true?

- (1) Her aunt has single eyelids.
  - (2) Her father has double eyelids.
  - (3) Her brother has single eyelids.
  - (4) Her grandfather has double eyelids.
9. The diagram shows the water cycle with processes A and B.

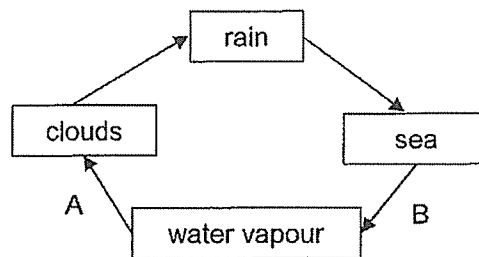

Which statement about process A or B is correct?

- (1) Water loses heat during process A.
- (2) Water gains heat during process B.
- (3) Process B takes place at a fixed temperature.
- (4) There is no change in the state of matter during process A.

10. Shariq filled identical containers Q, R and S, with 50 ml of water each and covered them with different lids as shown. He left the containers at the Science lab and measured the volume of water left in each container after three hours.

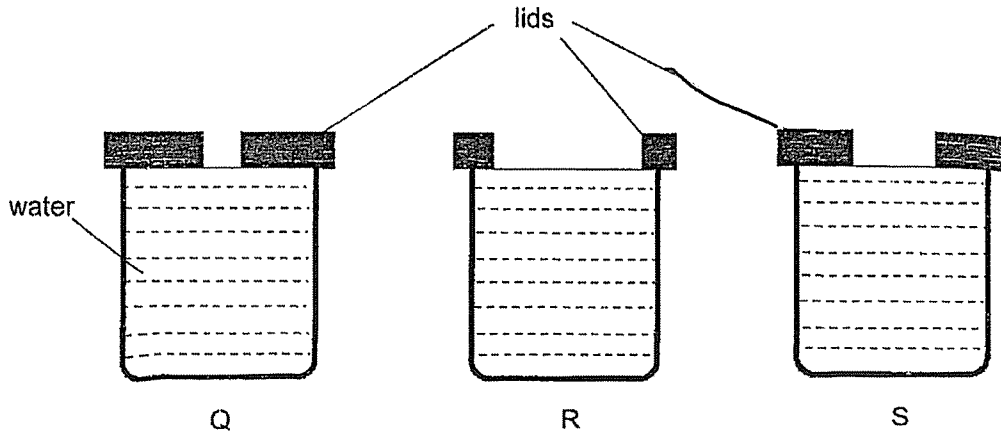

Which of the following graph shows the correct volumes of water left in containers Q, R and S, after three hours?

(1) Volume of water left (ml)

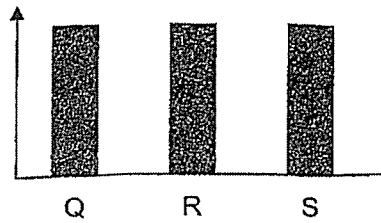

(2) Volume of water left (ml)

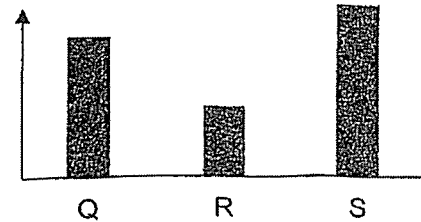

(3) Volume of water left (ml)

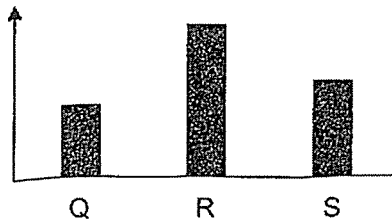

(4) Volume of water left (ml)

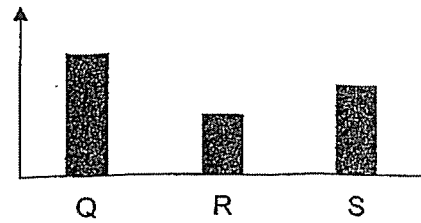

11. The diagram shows the arrangement of five magnets.

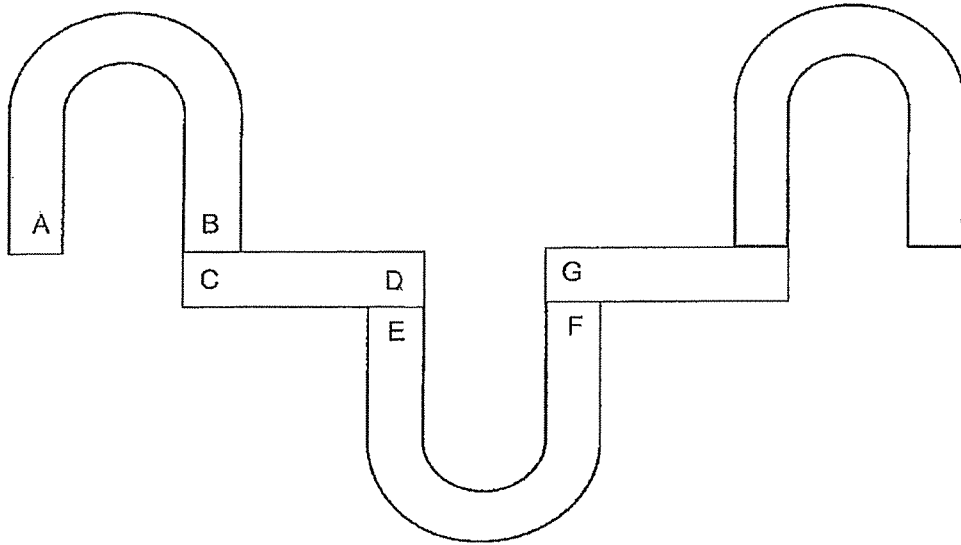

Which of the following arrangements is **not** possible?

(1)

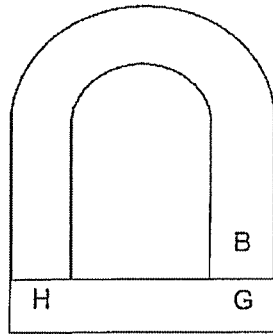

(2)

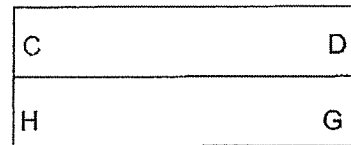

(3)

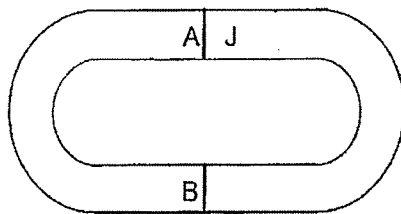

(4)

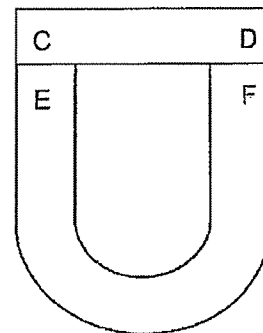

12. Adam used the stroke method to make the iron nail into a temporary magnet as shown. He then placed the temporary magnet near some steel clips. Only one steel clip was attracted to the temporary magnet.

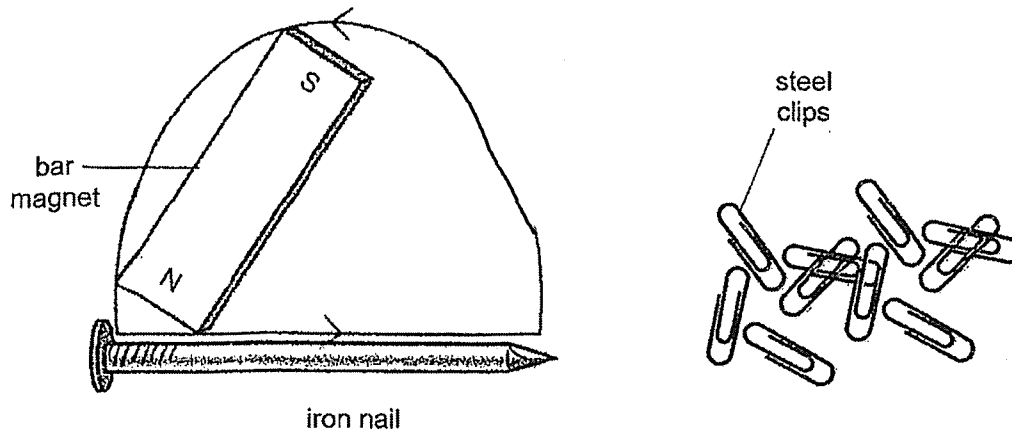

What should he do to the temporary magnet so that it can attract more steel clips?

- A Put it over a flame.
  - B Drop it from a height.
  - C Bring it nearer to the steel clips.
  - D Stroke it more times using the North pole of the bar magnet in the same direction.
- (1) C only  
 (2) C and D only  
 (3) A and B only ✗  
 (4) A, B and D only



13. Peter labelled one end of objects J, K, L and M as X. He brought each end of a magnet towards end X of all four objects.

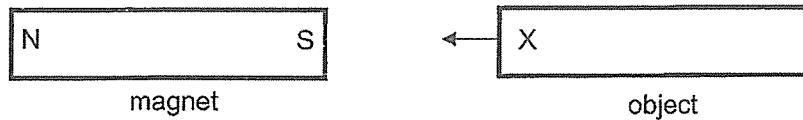

He recorded the interactions in the table as shown.

Object	When North pole of the magnet was brought near end X	When South pole of the magnet was brought near end X
J	Attracted	Attracted
K	No interaction	No interaction
L	Attracted	Repelled
M	Repelled	Attracted

Which of the following statement(s) is/are correct?

- A Object J is made of aluminium.
- B Objects J, L and M are magnets.
- C Object K is made of a non-magnetic material.

- (1) C only
- (2) A and B only
- (3) A and C only
- (4) A, B and C

14. Which parts of the body are correctly matched to the human organ systems?

	Digestive system	Respiratory system	Skeletal system
(1)	mouth	heart	skull
(2)	stomach	lungs	muscles
(3)	blood vessels	nose	ribcage
(4)	large intestine	windpipe	backbone

15. The diagram shows a plant.

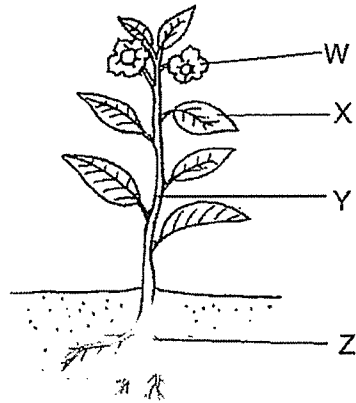

Which statement(s) is/are correct?

- A Part X makes food.
- B Part W contains seeds.
- C Part Y holds the plant upright.
- D Part Z takes in water and mineral salts.

- (1) A only
- (2) B and C only
- (3) A, C and D only
- (4) B, C and D only

16. The diagram shows the movement of food and water in a plant.

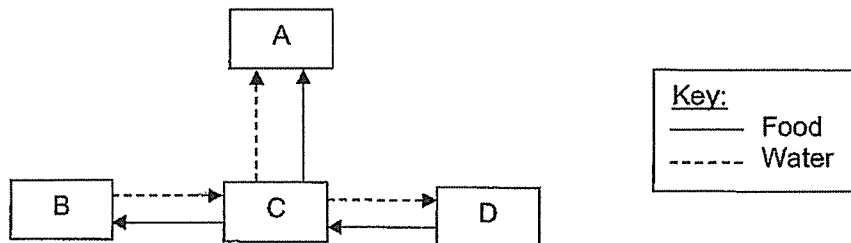

What are parts A, B, C and D?

	A	B	C	D
(1)	Fruit	Roots	Stem	Leaves
(2)	Roots	Stem	Leaves	Fruit
(3)	Fruit	Leaves	Stem	Roots
(4)	Leaves	Stem	Roots	Fruit

17. A potted plant was placed in a glass container and left in the garden. The amount of carbon dioxide in the glass container was measured and recorded over 24 hours in the graph as shown.

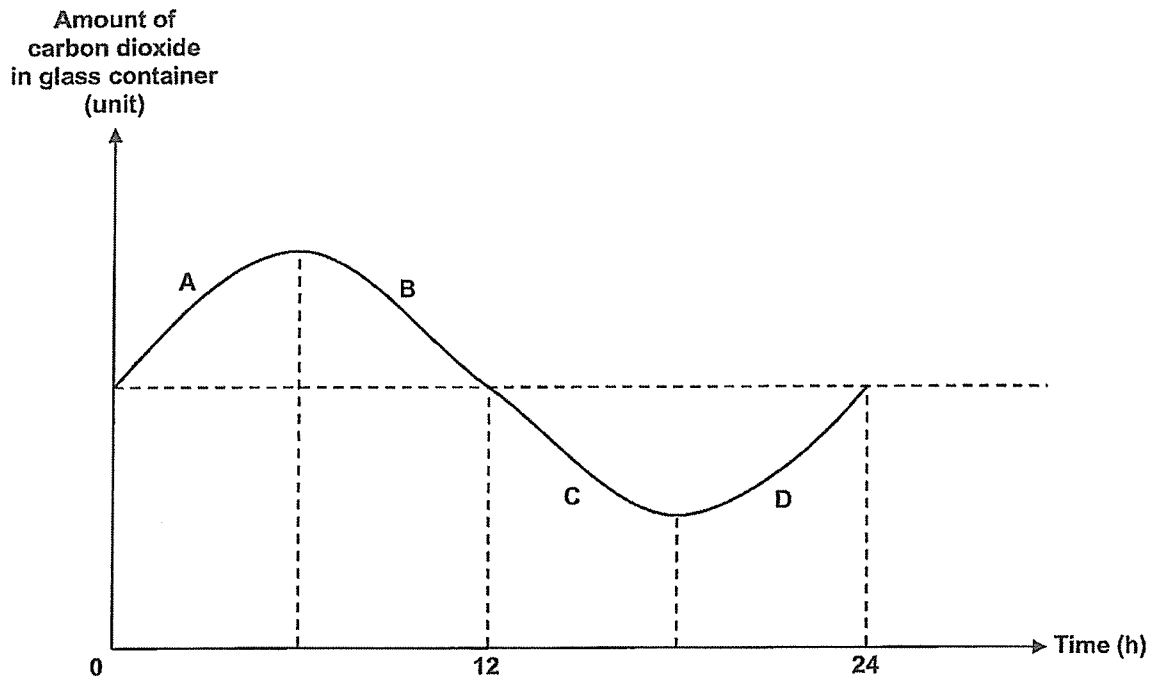

Which two parts of the graph show that the plant was carrying out photosynthesis?

- (1) A and B
- (2) B and C
- (3) C and D
- (4) A and D

18. The diagram shows the flow of blood in the human body. X and Y represent organs in the human body while P, Q, R, S, T and U represent the blood vessels in the body.

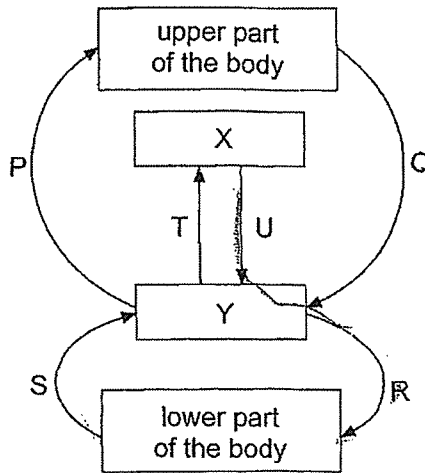

Which of the following correctly represents organs X and Y and describes the amount of oxygen and carbon dioxide in the blood of the blood vessels?

	X	Y	Blood rich in oxygen	Blood rich in carbon dioxide
(1)	Lungs	Heart	P, R and T	Q, S and U
(2)	Heart	Lungs	P, S and T	Q, R and U
(3)	Lungs	Heart	P, R and U	Q, S and T
(4)	Heart	Lungs	Q, R and U	P, S and T

19. The table lists some information about four cell parts.

Which of the following is correct?

	Cell part	Function of cell part	Present in animal cell?	Present in plant cell?
(1)	Cytoplasm	Controls the movement of substances in and out of the cell.	Yes	Yes
(2)	Chloroplast	Contains chlorophyll which traps light to make food.	No	Yes
(3)	Cell Membrane	Allows the movement of substances within the cell.	Yes	No
(4)	Cell Wall	Protects the cell and gives it a fixed shape.	Yes	Yes

20. Circuits P, Q, R and S are set up using identical batteries and bulbs, which are in working condition.

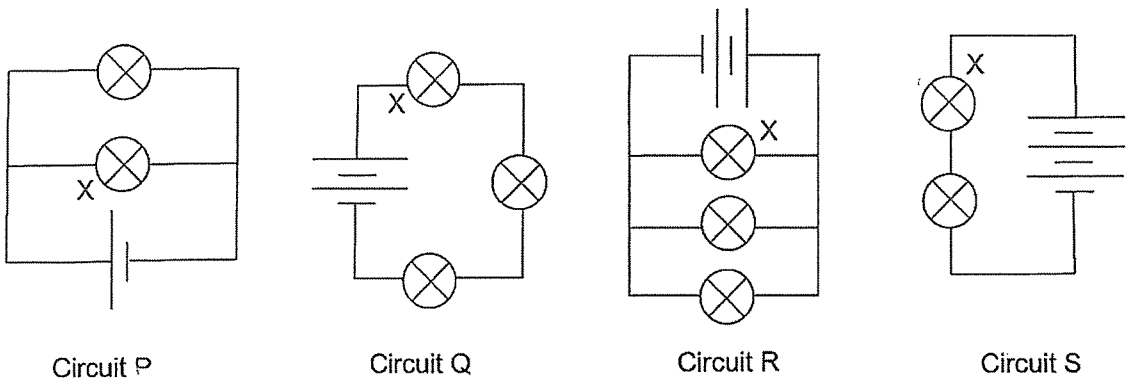

Which of the following shows the correct order of the brightness of bulb X in each circuit, from the dimmest to the brightest?

- (1) S, R, Q, P
  - (2) Q, P, S, R
  - (3) P, Q, R, S
  - (4) R, S, P, Q
21. Ari used a syringe to pump  $100 \text{ cm}^3$  of air into a container with a volume of  $250 \text{ cm}^3$ .

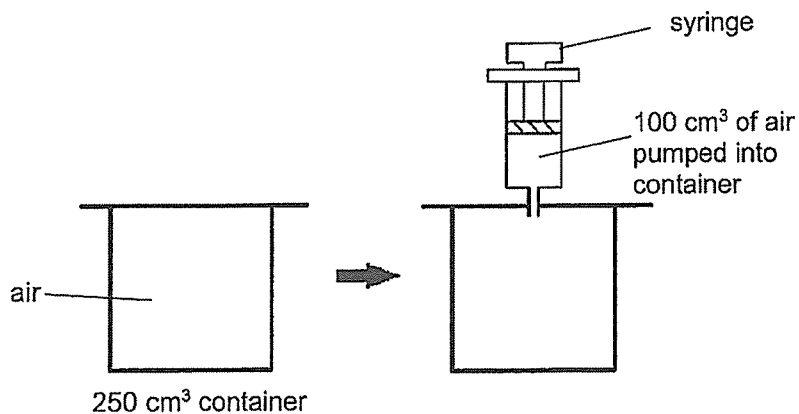

After  $100 \text{ cm}^3$  of air was pumped in, which of the following about the mass and volume of air in the container is correct?

	Mass of air in container	Volume of air in container
(1)	increased	increased
(2)	increased	remained the same
(3)	remained the same	increased
(4)	remained the same	remained the same

22. Anna used a circuit tester to test a circuit card. She connected points X and Y of the circuit tester to the metal pins A, B, C, D and E on the circuit card and observed if the bulb would light up.

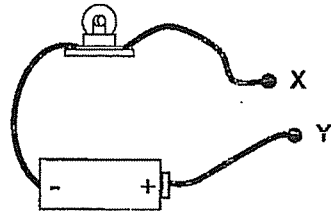

circuit tester

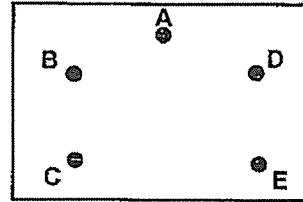

circuit card

She recorded the results in the table.

Metal pins connected	Did the bulb light up?
A and B	No
A and C	Yes
C and D	Yes
D and E	No

Which circuit card did Anna test?

<p>(1)</p>	<p>(2)</p>
<p>(3)</p>	<p>(4)</p>

23. Jeffri sets up two circuits using similar electrical components in working condition and four objects, A, B, C and D, as shown.

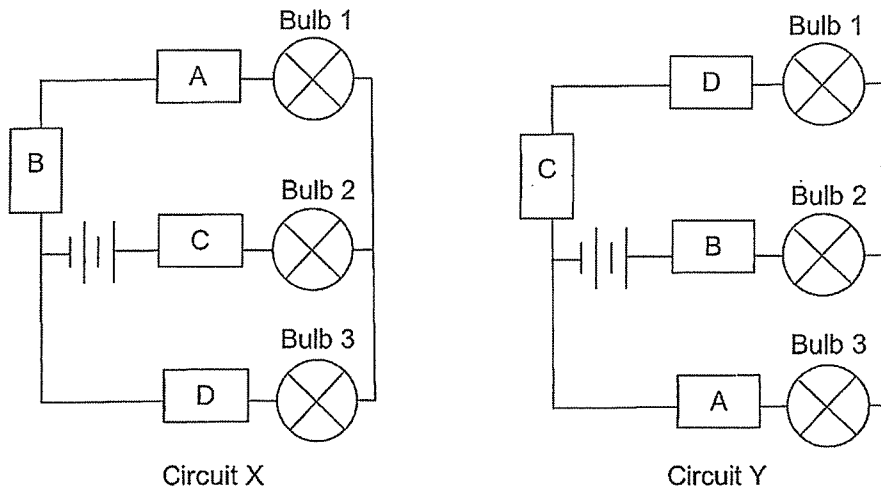

The table shows the results of his experiment.

	Did the bulbs light up?		
	Bulb 1	Bulb 2	Bulb 3
<b>Circuit X</b>	No	No	No
<b>Circuit Y</b>	No	Yes	Yes

Which one of the following is correct?

	Conductors of electricity	Non-conductors of electricity	Not possible to tell
(1)	A	B	C and D
(2)	A	None	B, C and D
(3)	A and B	C and D	None
(4)	A and B	C	D

24. The diagram shows a man walking down a street from lamp A to lamp D. Of the four street lamps along the street, only one was lighted up. The street lamps were the same distance apart from each other.

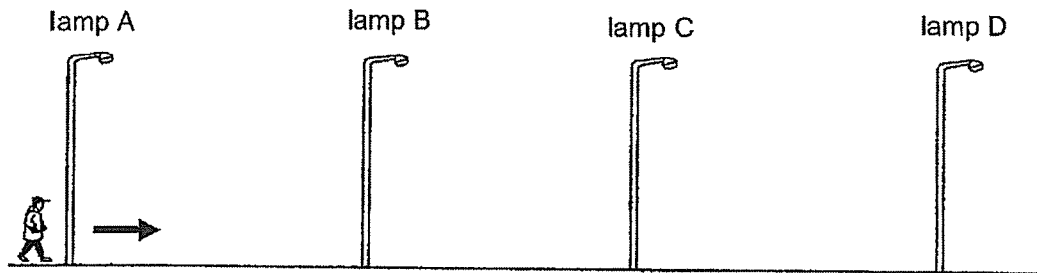

The graph shows how the length of his shadow changes as he walked from lamp A to lamp D.

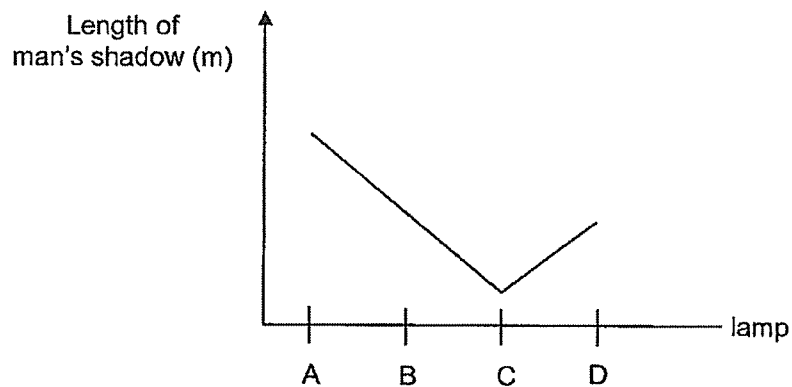

Based on the graph, which street lamp, A, B, C, or D, was lighted up?

- (1) A
- (2) B
- (3) C
- (4) D



25. Ryan set up an experiment using three identical beakers, each containing a different liquid as shown. The volume of liquid in each beaker and the intensity of light from the torches are the same.

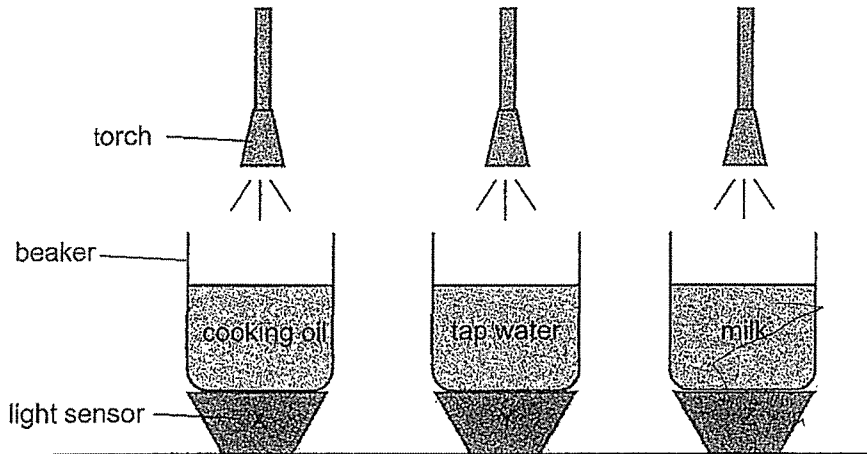

He used identical light sensors, X, Y and Z, to measure the amount of light that passed through each beaker of liquid and recorded the readings.

Which is the most likely reading from the light sensors?

Units of light			
	X	Y	Z
(1)	0	200	100
(2)	200	100	0
(3)	0	100	200
(4)	100	200	0

26. Susie poured herself a glass of water. She then added some ice cubes and a metal spoon to the glass of water as shown.

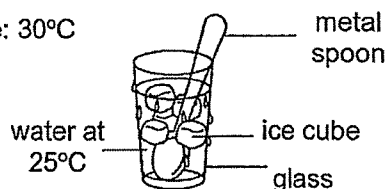

Which two statements are **incorrect**?

- A The glass loses heat to ice cubes.
- B The ice cubes gain heat from the water.
- C The water loses heat to the surrounding air.
- D The metal spoon gains heat from the ice cubes.

- (1) A and B
- (2) B and C
- (3) C and D
- (4) A and D

27. An experiment was carried out using the two identical set-ups with different volumes of water as shown. The Bunsen burners were turned on at the same time to heat the water in the beakers until the water reached 100°C.

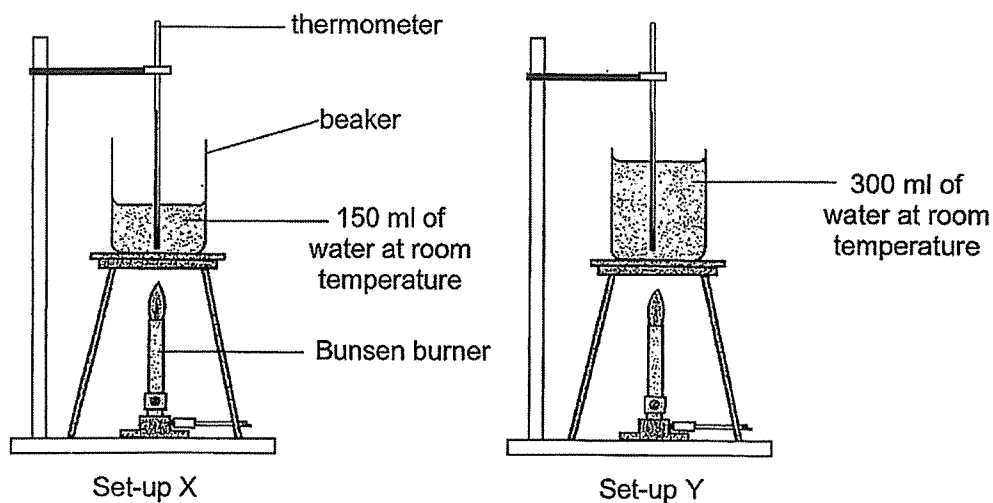

Which statement is correct?

- (1) Water in both set-ups have the same amount of heat.
- (2) Water in both set-ups reached 100°C at the same time.
- (3) Water in Set-up X has more heat than the water in Set-up Y.
- (4) Water in Set-up X will reach 100°C faster than the water in Set-up Y.

28. The diagram shows a leaf of a plant partially covered with black paper on both sides of the leaf.

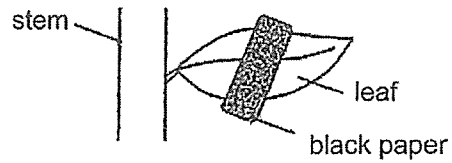

The plant was then placed in an area with plenty of sunlight and given sufficient water daily. After five days, the same leaf was tested for starch using iodine solution. Iodine solution changes from brown to blue-black in the presence of starch.

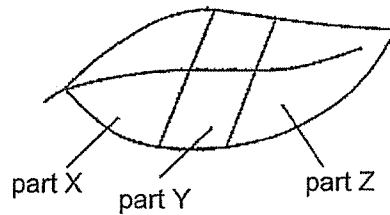

Which part(s) of the leaf would the iodine solution remain brown?

- (1) Part X only
- (2) Part Y only
- (3) Parts X and Z only
- (4) Parts X, Y and Z only

**End of Booklet A**



SCHOOL : ACS (J) PRIMARY SCHOOL  
LEVEL : PRIMARY 5  
SUBJECT : SCIENCE  
TERM : 2024 WA2

---

Q 1	Q2	Q3	Q4	Q5	Q6	Q7	Q8	Q9	Q10
2	2	1	4	2	4	2	1	2	4
Q11	Q12	Q13	Q14	Q15	Q16	Q17	Q18	Q19	Q20
4	2	1	4	3	1	2	3	2	2
Q21	Q22	Q23	Q24	Q25	Q26	Q27	Q28		
2	3	4	3	4	3	4	2		

sgTestpaper.com  
has more papers

