

Anglo-Chinese School (Junior)
P5 Science EYE Revision Paper 1

Name: _____ () P: 5. () Date: _____

For each question from 1 to 28, four options are given. One of them is the correct answer. Make your choice (1, 2, 3 or 4). Shade your answer on the Optical Answer Sheet.

(56 marks)

1. Jaryl carried out an experiment as shown. He placed the same amount of mushroom spores in two bags with the same amount of wet soil and left the bags in different rooms at the same temperature.

The diagrams show what he observed after a week.

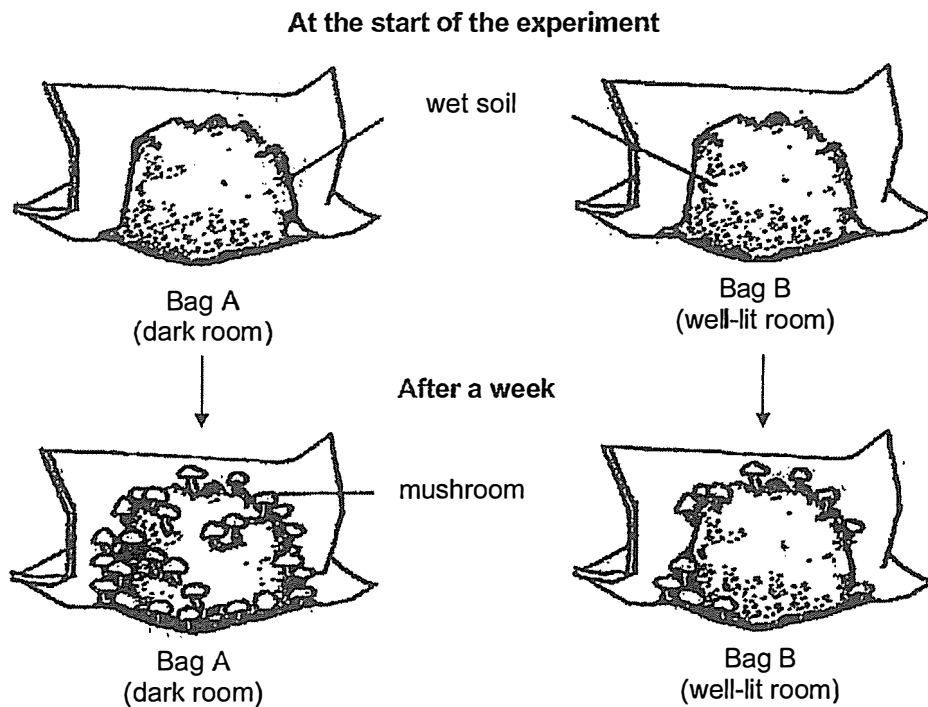

Which condition increased the rate of reproduction in mushrooms?

- (1) Absence of air
- (2) Absence of light
- (3) Presence of soil
- (4) Presence of water

2. Study the flowchart of materials A, B, C and D.

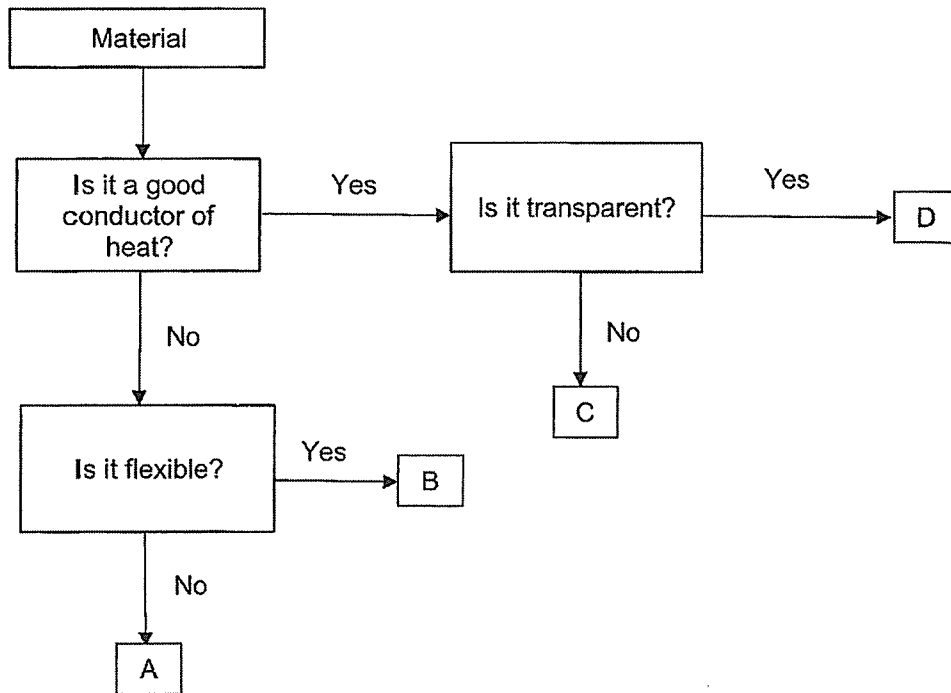

All firefighters need to put on a firefighter suit as a safety feature when they put out fires.

Based on the flowchart, which material is most suitable for making the suit?

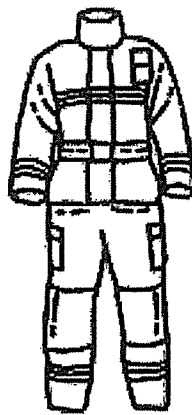

A firefighter suit

- (1) A
- (2) B
- (3) C
- (4) D

3. The diagrams show the stages in the life cycles of two insects.

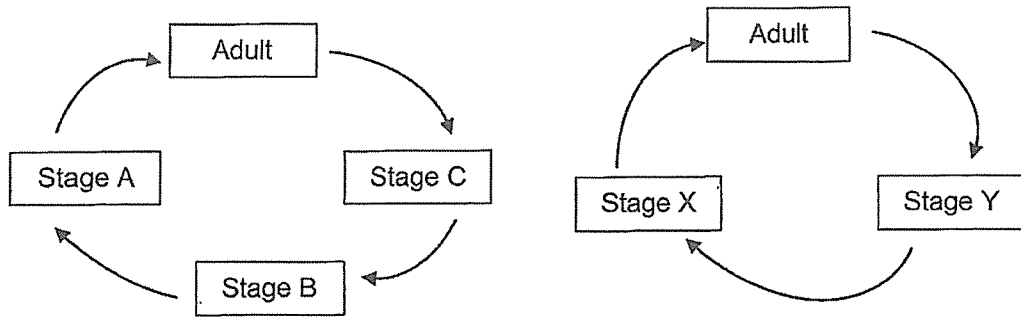

Which of the following are stages A and X?

	Stage A	Stage X
(1)	nymph	larva
(2)	larva	egg
(3)	egg	pupa
(4)	pupa	nymph

4. The development of a flowering plant is described in the table.

	Development
A	Some flowers develop into fruits with seeds
B	Seeds are planted in the ground
C	Shoot grows upwards
D	Plant grows taller and bears flowers

Which of the following shows the correct order of the development of the flowering plant?

- (1) A, B, D, C
- (2) A, D, C, B
- (3) B, C, D, A
- (4) B, D, A, C

5. Elliott filled two identical measuring cylinders with 50 ml of water. When he placed two solid objects, A and B, into the measuring cylinders, the water in both measuring cylinders overflowed.

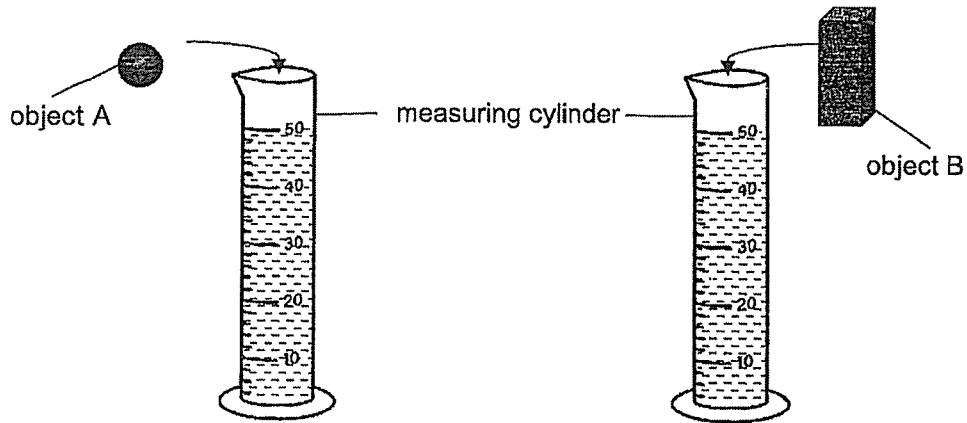

Which statement about objects A and B is correct?

- (1) A has more mass than B.
 - (2) A occupies more space than B.
 - (3) B will displace more water than A.
 - (4) The volume of water that overflowed is the volume of the objects.
6. Study the diagram.

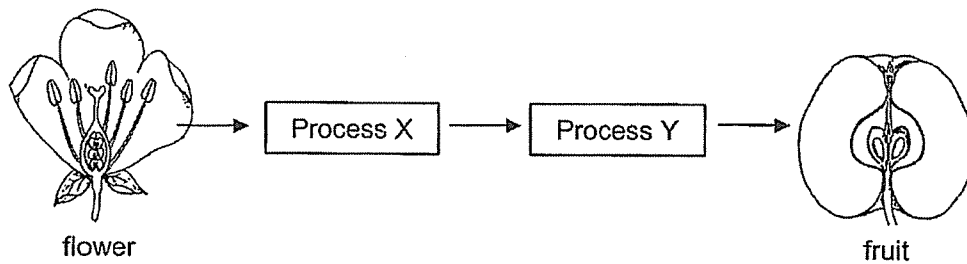

Which of the following correctly represents processes X and Y?

	Process X	Process Y
(1)	Pollination	Fertilisation
(2)	Pollination	Germination
(3)	Fertilisation	Pollination
(4)	Germination	Fertilisation

7. Study the seed dispersal pattern of plants A, B and C.

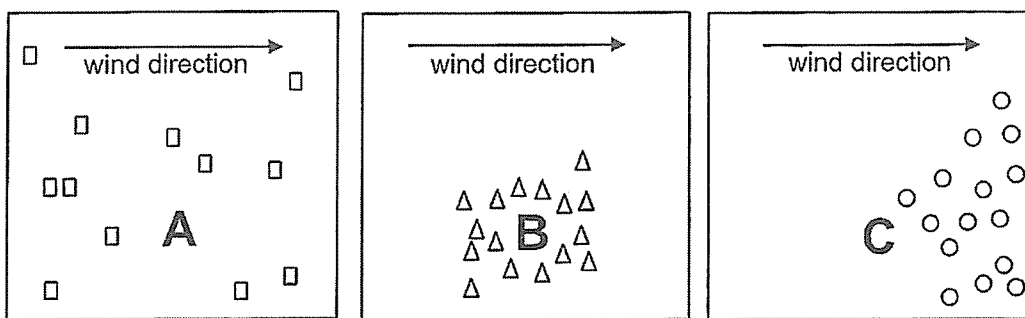

Key:

- seed of A
- △ seed of B
- seed of C

What characteristics do the fruits/seeds of plants A, B and C have?

	Plant A	Plant B	Plant C
(1)	fleshy fruit	pod	wing-like structure
(2)	fibrous husk	hooks	pod
(3)	hooks	fibrous husk	wing-like structure
(4)	fleshy fruit	pod	hooks

8. Study the two human reproductive systems as shown.

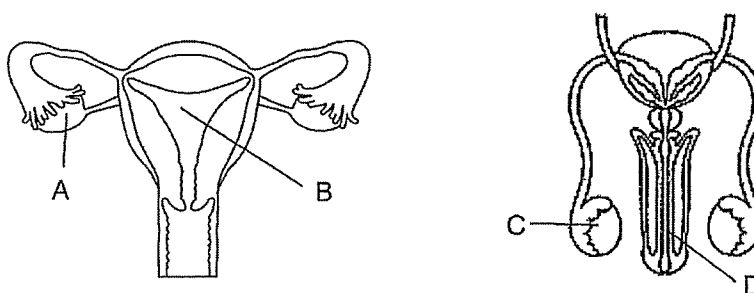

Which of the following is correct?

- (1) Fertilisation occurs in B and D.
- (2) The fertilised egg is found in A.
- (3) Only one sperm will be released through D.
- (4) Reproductive cells are produced in A and C.

9. Hannah opened the lid of a rice cooker after cooking some rice. She saw white mist coming out of the rice cooker as shown.



What is the state of the mist and how did the mist form?

	State of mist	How the mist formed
(1)	liquid	water vapour gained heat from the cooked rice
(2)	liquid	water vapour lost heat to the surroundings
(3)	gas	water vapour gained heat from the cooked rice
(4)	gas	water vapour lost heat to the surroundings

10. Jinhao placed identical glasses with 200 ml of water at 10°C in different locations, A and B. After three minutes, he noticed some water droplets on the glasses as shown.

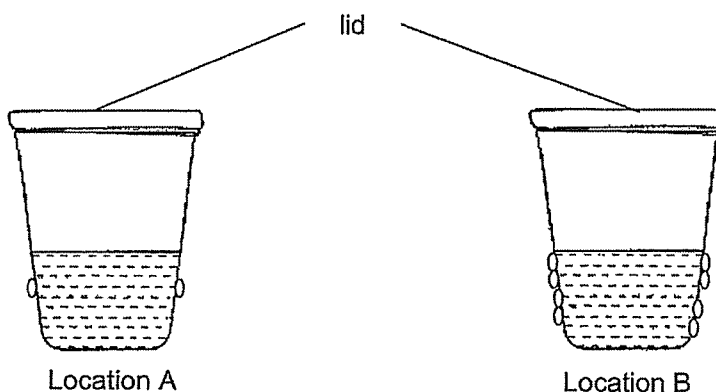

Which of the following is most likely the temperature of the location where glasses A and B were placed?

	A	B
(1)	15°C	40°C
(2)	30°C	10°C
(3)	10°C	15°C
(4)	40°C	30°C

11. Which of the following is a possible effect on the water cycle when the temperature of the environment decreases?
- (1) Rate of evaporation of water decreases resulting in less rain.
 - (2) Rate of condensation of water vapour decreases resulting in more rain.
 - (3) Rate of condensation of water vapour increases causing less clouds to form.
 - (4) Rate of evaporation of water increases causing more water vapour to form in the air.
12. Farhan used strings to hang three similar magnets, with ends QR, WX and YZ from a plastic rod as shown.

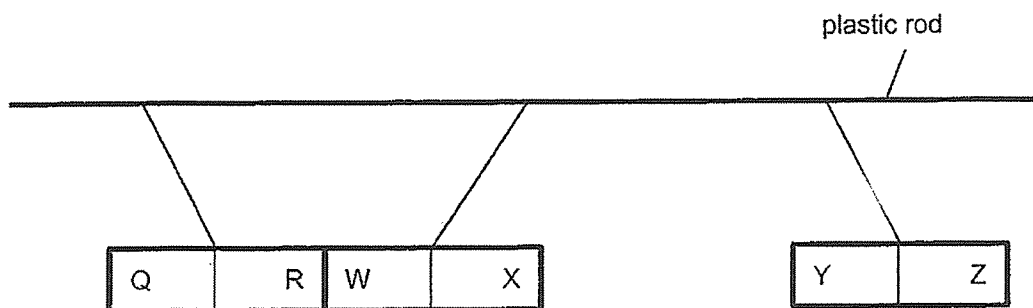

Which two statements are true?

- A X and Y are repelling.
 - B Q and Y are like poles.
 - C R and W are unlike poles.
 - D R and Y will attract when facing each other.
- (1) A and B
 - (2) A and C
 - (3) B and D
 - (4) C and D

13. Wenjie hung four magnets, W, X, Y and Z, above a tray of identical steel clips as shown.

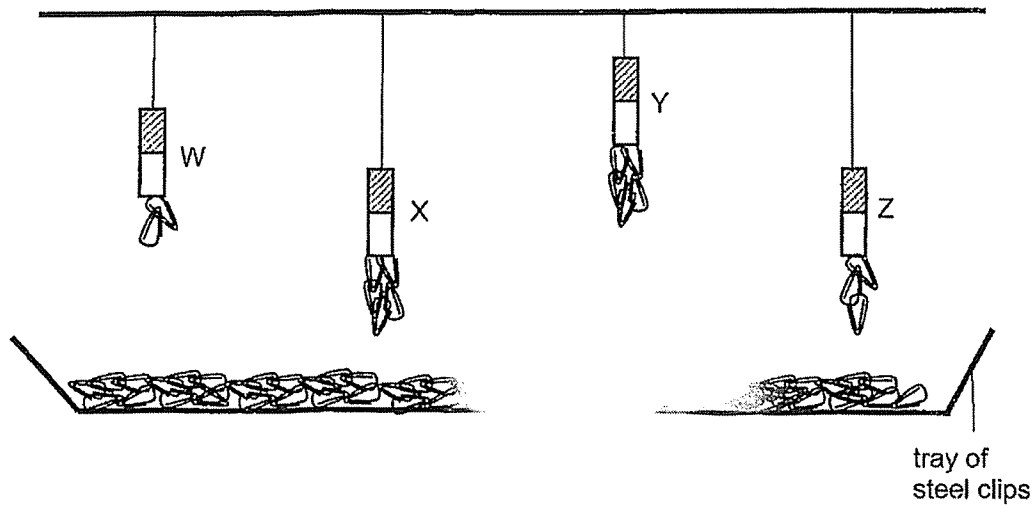

Which of the following conclusions is **not** possible?

- (1) Y is a stronger magnet than X.
 - (2) X is a stronger magnet than Z.
 - (3) W is a stronger magnet than Z.
 - (4) Y is a stronger magnet than W.
14. Which of the following actions will increase the strength of the electromagnet?

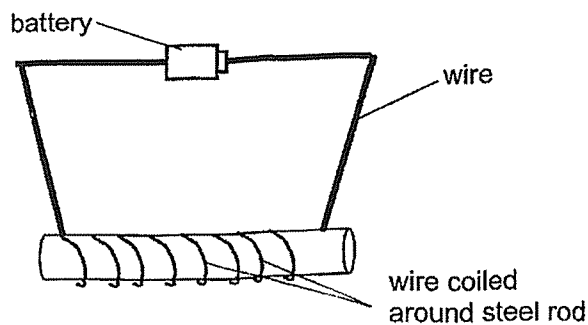

- A Adding a bulb to the circuit.
 - B Adding more batteries to the circuit.
 - C Increasing the number of coils of wire.
- (1) A only
 - (2) C only
 - (3) A and B only
 - (4) B and C only

15. The diagram shows an animal.

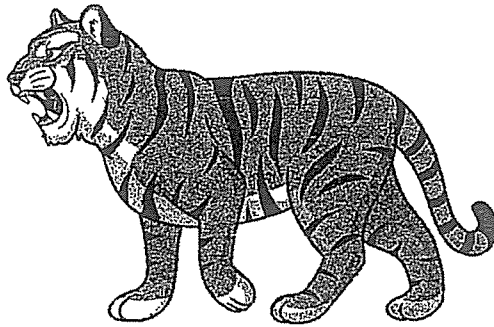

Which of the following statements are true?

- A The animal is made up of many cells.
 - B All the cells in the animal have a cell membrane.
 - C The cells in the animal are of different shapes and sizes.
 - D All the cells in the animal have a cell wall which gives the animal its shape.
- (1) A and C only
(2) B and D only
(3) A, B and C only
(4) A, C and D only
16. Which statement about the human skeletal system is **incorrect**?
- (1) The skull protects the brain.
 - (2) The skeletal system supports the body.
 - (3) The ribcage protects the heart, lungs, and stomach.
 - (4) The skeletal system gives the human body its shape.

17. The diagram shows a tree.

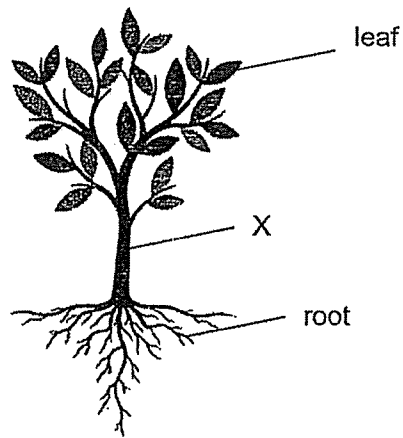

Which direction does water and food move at part X of the tree?

	Direction of movement of water	Direction of movement of food
(1)	Upwards only	Downwards only
(2)	Downwards only	Upwards only
(3)	Upwards only	Upwards and downwards
(4)	Downwards only	Upwards and downwards

18. Marcus conducted an experiment to find out how the number of leaves a plant has affects the rate of photosynthesis. He prepared set-up 1 as shown and recorded the number of bubbles produced in each set-up for one minute in the table. He repeated the experiment with set-up 2 and 3.

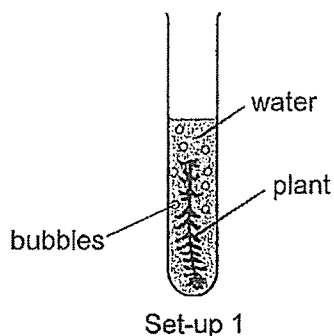

Set-up	Type of plant	Size of leaves	Number of leaves	Location
1	X	small	30	Garden
2	Y	medium	22	Garden
3	Z	large	10	Garden

Marcus' teacher told him that his experiment is not fair. Which change(s) should Marcus make to the set-ups to ensure he can test his aim?

- A Use the same type of plant.
- B Put the plants in different locations.
- C Use plants with the same size of leaves.
- D Use plants with the same number of leaves.

- (1) D only
- (2) A and C only
- (3) B and D only
- (4) A, B and C only

19. The diagram shows four electrical circuits, A, B, C and D.

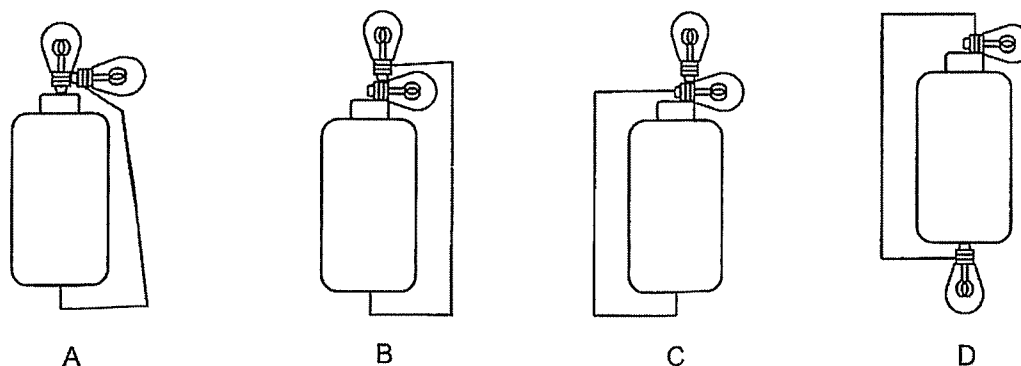

In which circuit(s) will only one bulb light up?

- (1) A only
 - (2) B and C only
 - (3) B, C and D only
 - (4) A, B, C and D
20. Sameer found a plant with a broken stem and placed it in a beaker of water as shown. He wrapped the roots of the plant with a plastic bag and placed it next to the window.

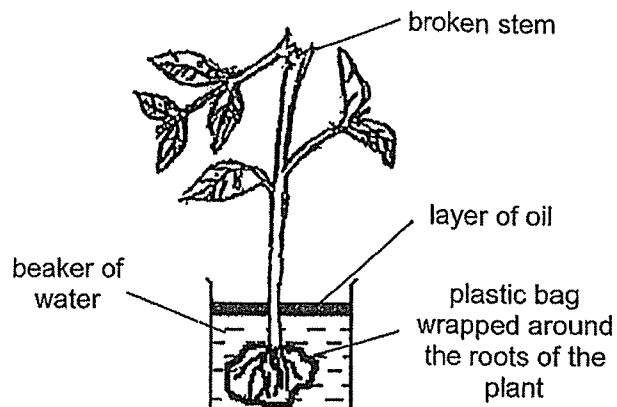

Which of the following explains why the plant died after a few days?

- (1) The roots were not able to take in water.
- (2) The plant could not bear fruit as there were no flowers.
- (3) The leaves of the plant were unable to reach for sunlight.
- (4) Food could not be transported to the roots as the stem broke.

21. Adrian set up an electrical circuit.

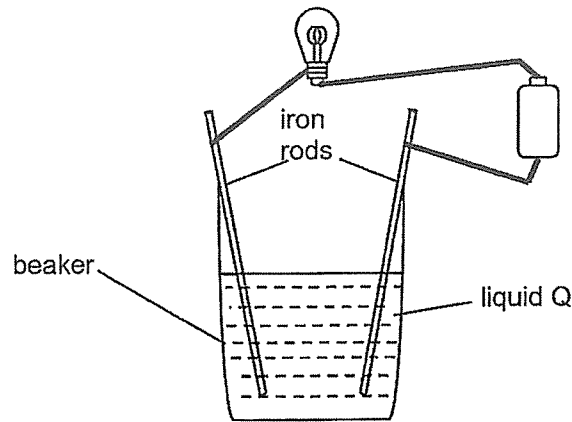

The bulb does not light up in the circuit.

Which of the following is **not** a possible conclusion?

- (1) The bulb has fused.
 - (2) The circuit is an open circuit.
 - (3) Liquid Q is an insulator of electricity.
 - (4) The iron rods are electrical insulator.
22. A piece of copper wire was hung in the garden as shown.

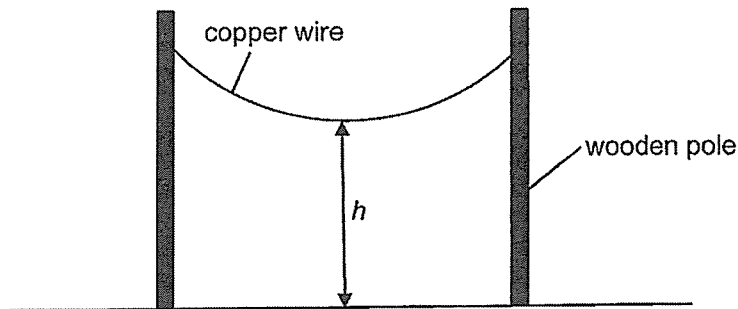

The temperature in the garden dropped to 5°C at night.

Which observation of h and the explanation is correct?

	Observation of h	Explanation
(1)	Increased	The copper wire contracted.
(2)	Increased	The copper wire is a poor conductor of heat.
(3)	Decreased	The copper wire expanded.
(4)	Remain the same	The copper wire conducts heat.

23. Bernard set up an experiment with two identical balloons, P and Q, balanced on a beam as shown.

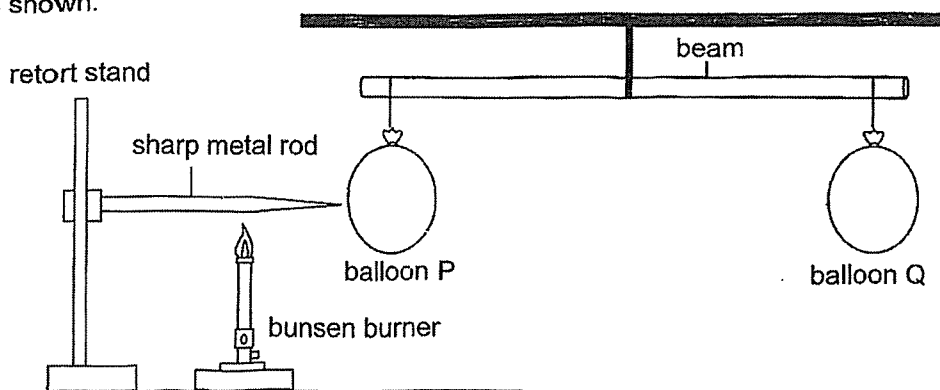

Which of the following will Bernard observe after he heats the metal rod with the bunsen burner for 30 minutes?

- (1) The beam will remain balanced.
 - (2) The mass of balloon P increased.
 - (3) The beam will tilt down towards balloon P.
 - (4) The beam will tilt down towards balloon Q.
24. The diagram shows the top view of a well-lit tunnel with mirrors placed at various corners as shown.

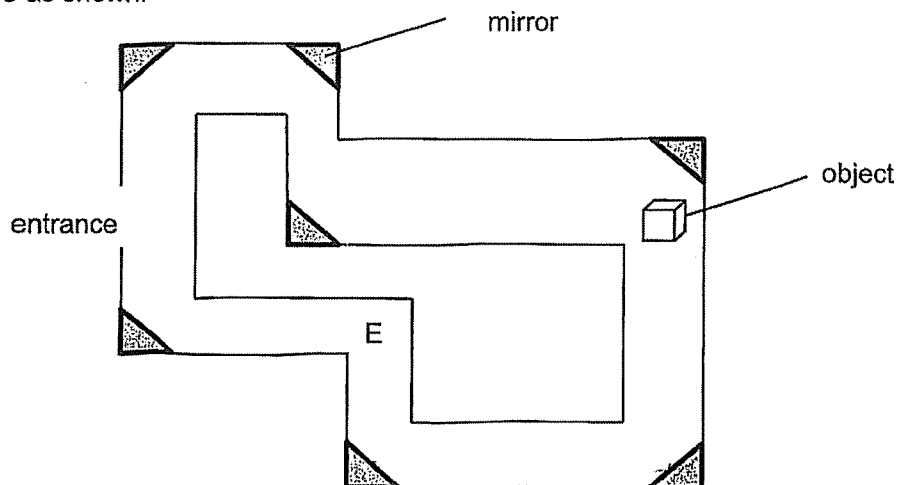

Jovan is standing at point E. What is the least number of mirrors that Jovan needs to use to see the object?

- (1) 1
- (2) 2
- (3) 3
- (4) 4

25. Dan Heng placed the following set-up in a dark room. He measured the amount of light from the bulb passing through the tracing paper.

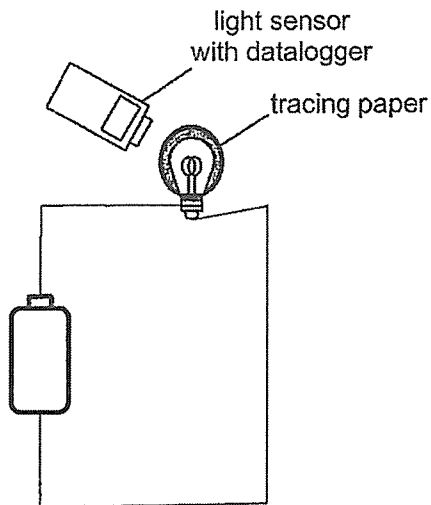

He changed variable X in his experiment. The graph shows the results.

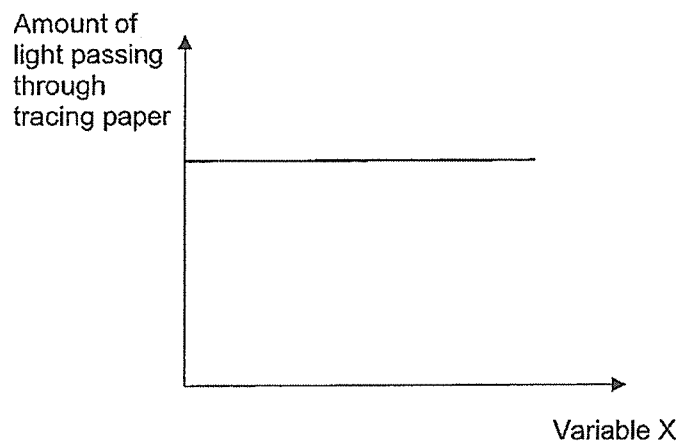

What could variable X be?

- (1) Thickness of tracing paper
- (2) Number of bulbs arranged in series
- (3) Number of bulbs arranged in parallel
- (4) Distance between tracing paper and the light sensor

26. The diagram shows three objects, A, B and C, of the same height placed at different distances from the light source. The three objects did not block one another.

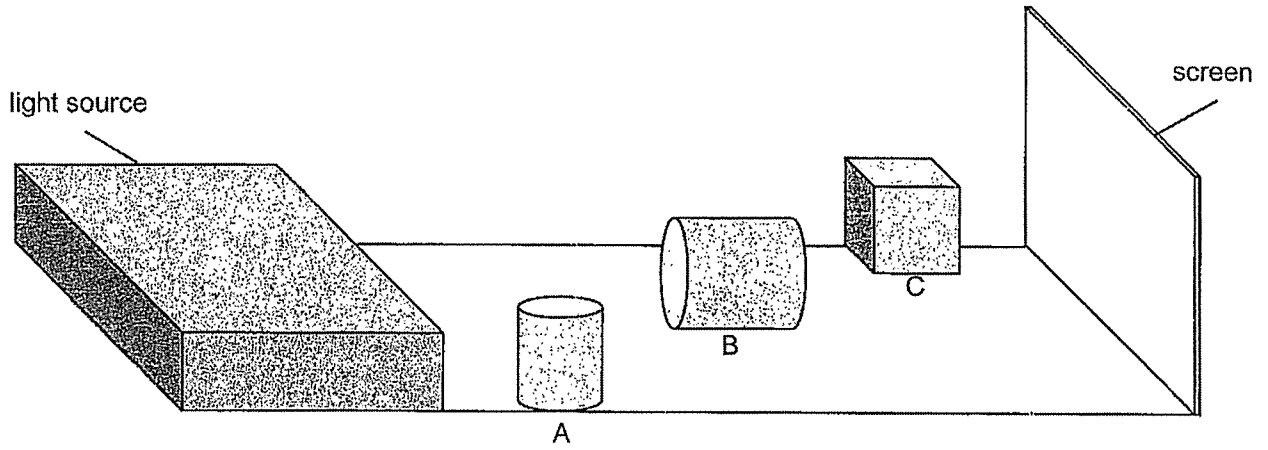

Which of the following correctly shows the shadows of objects of A, B and C cast on the screen when the light source was switched on?

	A	B	C
(1)			
(2)			
(3)			
(4)			

27. Which of the following statements about the human circulatory system is correct?

- (1) Digested food enters the bloodstream at the large intestine.
- (2) Carbon dioxide is absorbed into the bloodstream at the lungs.
- (3) The heart pumps blood containing substances to all parts of the body.
- (4) Water is transported to all parts of the body by the water-carrying tubes.

28. The diagrams show four different organisms.

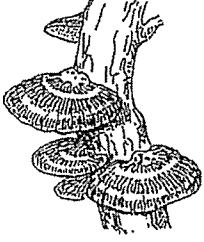
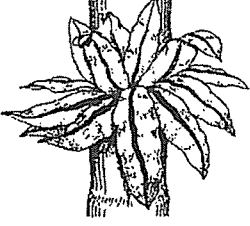
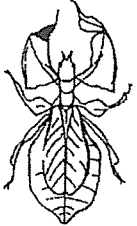
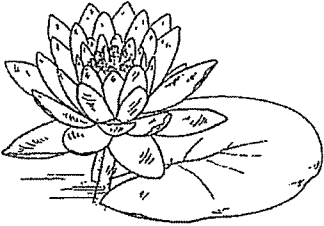
A	 <p data-bbox="523 846 699 875">bracket fungus</p>	B	 <p data-bbox="1029 846 1204 875">bird's nest fern</p>
C	 <p data-bbox="571 1173 699 1202">leaf insect</p>	D	 <p data-bbox="1074 1173 1182 1202">water lily</p>

Which of the following organisms get their energy directly from the sun?

- (1) A and C only
- (2) B and D only
- (3) A, B and C only
- (4) B, C and D only

End of Booklet A

SCHOOL : ACS (J) PRIMARY SCHOOL
 LEVEL : PRIMARY 5
 SUBJECT : SCIENCE
 TERM : 2024 WA1

Q 1	Q2	Q3	Q4	Q5	Q6	Q7	Q8	Q9	Q10
2	2	4	3	3	1	1	3	2	1
Q11	Q12	Q13	Q14	Q15	Q16	Q17	Q18	Q19	Q20
1	2	3	4	3	3	1	2	3	1
Q21	Q22	Q23	Q24	Q25	Q26	Q27	Q28		
4	1	3	2	3	2	3	2		

sgTestPaper.com
 has more papers

