



MAHA BODHI SCHOOL  
2024 END OF YEAR EXAMINATION  
PRIMARY FIVE SCIENCE  
(BOOKLET A)

Name : \_\_\_\_\_ (      )

Class : Primary 5 \_\_\_\_\_

Date : 24 Oct 2024

Total Duration for Booklets A and B: 1 h 45 min

---

**INSTRUCTIONS TO CANDIDATES:**

1. Do not turn over this page until you are told to do so.
2. Follow all instructions carefully.
3. Answer all questions.
4. Shade your answers in the Optical Answer Sheet (OAS) provided.

This booklet consists of 20 printed pages.

**BLANK PAGE**

**BOOKLET A : [28 x 2 marks = 56 marks]**

For each question from 1 to 30, four options are given. One of them is the correct answer. Make your choice (1, 2, 3 or 4). Shade your answer on the Optical Answer Sheet.

1. The diagram shows a plant cell.

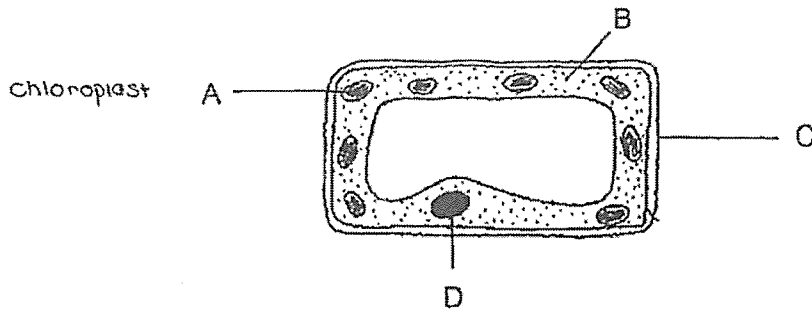

Which of the parts A, B, C or D are not present in animal cells?

- (1) A and B only
  - (2) A and C only
  - (3) B and C only
  - (4) B and D only
2. Study cells P and Q shown below.

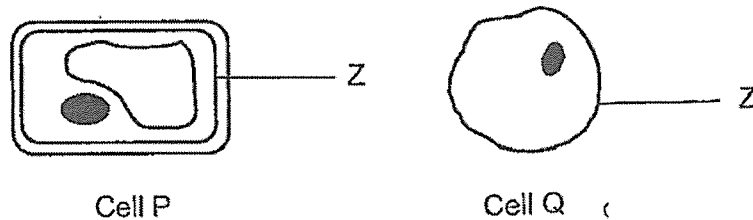

Which of the following gives the correct classification of the cells and the function of part Z?

	Animal cell	Plant cell	Function of part Z
(1)	P, Q	-	gives the cell a shape
(2)	P	Q	gives the cell a shape
(3)	Q	P	controls movement of substances in and out of cell
(4)	-	P, Q	controls movement of substances in and out of cell

3. Which of the following shows the substances transported by the human circulatory system and the plant transport system?

	human circulatory system	plant transport system
(1)	oxygen, digested food, waste materials	oxygen, food, water, carbon dioxide
(2)	oxygen, digested food, water, waste materials	food, water
(3)	oxygen, digested food, water, carbon dioxide	food, water, waste materials
(4)	oxygen, digested food, water, carbon dioxide	oxygen, food, water

4. Which of following diagrams correctly shows the flow of blood in the human circulatory system?

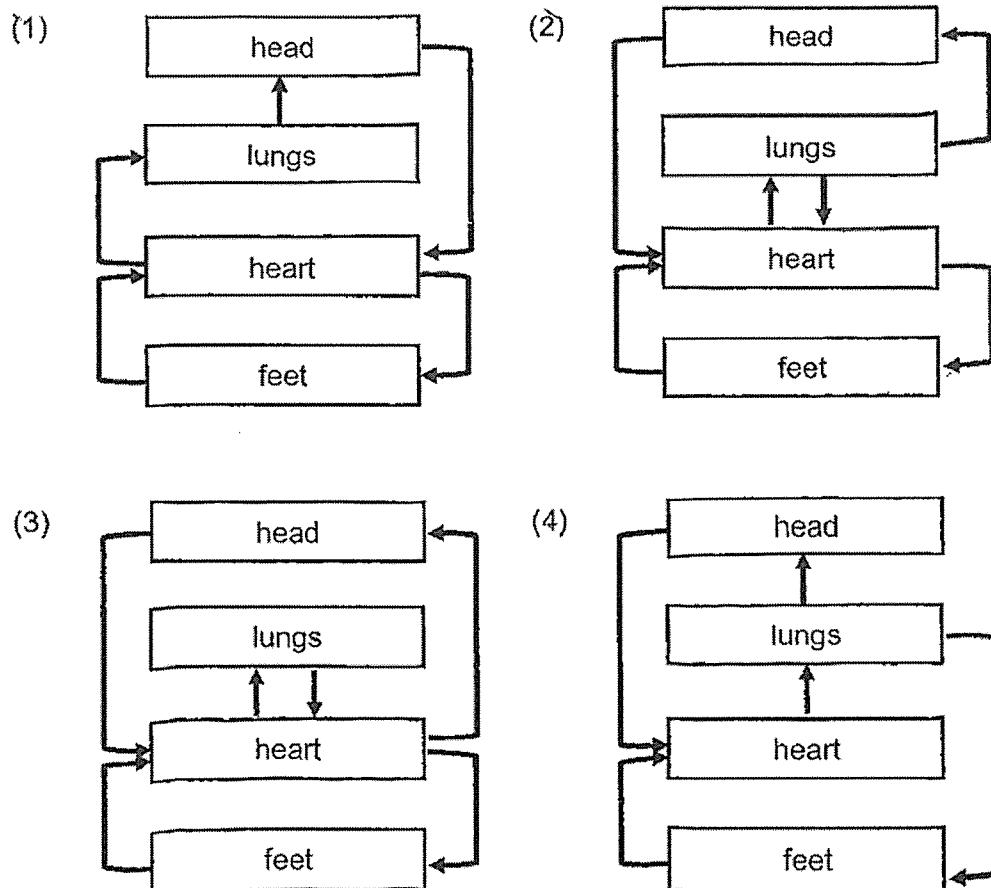

5. The diagram below shows the blood vessels, X and Y, which send blood towards and away from the small intestine.

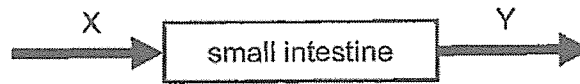

Which of the following shows the change in the amount of each substance in Y compared to that in X?

	oxygen	carbon dioxide	digested food
(1)	increase	decrease	increase
(2)	decrease	increase	decrease
(3)	increase	remains the same	decrease
(4)	decrease	increase	increase

6. Sam cut fruit X open and drew his observation as shown below.

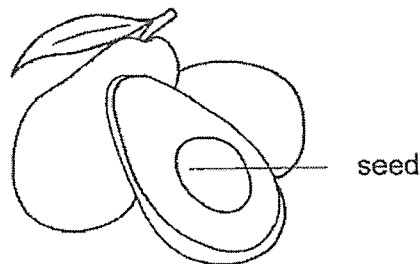

Based on his observation, which of the following statements is likely true about the flower that fruit X developed from?

- (1) The flower has only one ovule.
- (2) The flower does not have a stigma
- (3) The flower does not have male parts.
- (4) The flower went through pollination only before the fruit was developed.

7. The diagrams below show the transfer of pollen grains between flowers.

In which of the following will fertilisation most likely take place?

(1)

transfer of pollen

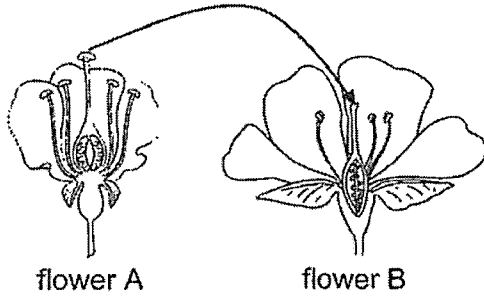

(2)

transfer of pollen

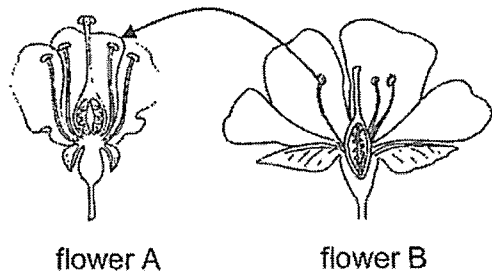

(3)

transfer of pollen

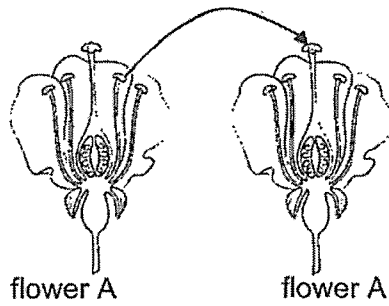

(4)

transfer of pollen

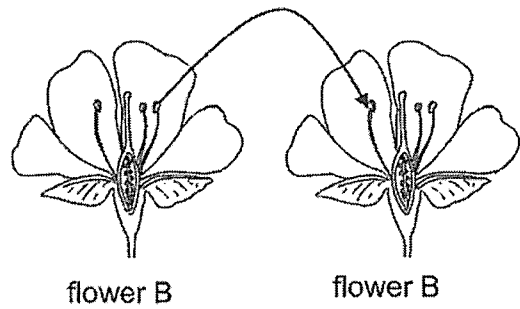

8. The diagram below shows the processes S, T and U, involved in the reproduction of flowering plants.

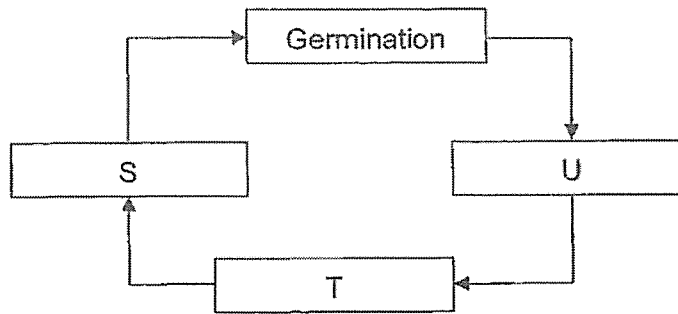

Which of the following correctly identifies the processes in the above diagram?

	<b>S</b>	<b>T</b>	<b>U</b>
(1)	seed dispersal	pollination	fertilisation
(2)	pollination	fertilisation	seed dispersal
(3)	seed dispersal	fertilisation	pollination
(4)	fertilisation	seed dispersal	pollination

9. Study the classification chart below.

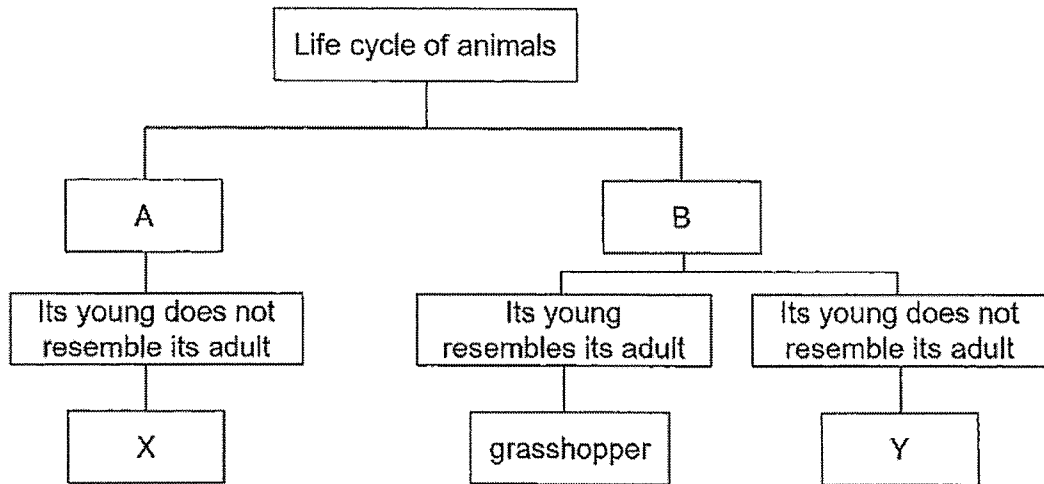

Which of the following correctly represents A, B, X and Y respectively?

	<b>A</b>	<b>B</b>	<b>X</b>	<b>Y</b>
(1)	3-stage life cycle	4-stage life cycle	cockroach	beetle
(2)	3-stage life cycle	4-stage life cycle	cockroach	frog
(3)	4-stage life cycle	3-stage life cycle	butterfly	chicken
(4)	4-stage life cycle	3-stage life cycle	butterfly	frog



10. Three cells were classified with the chart as shown below.

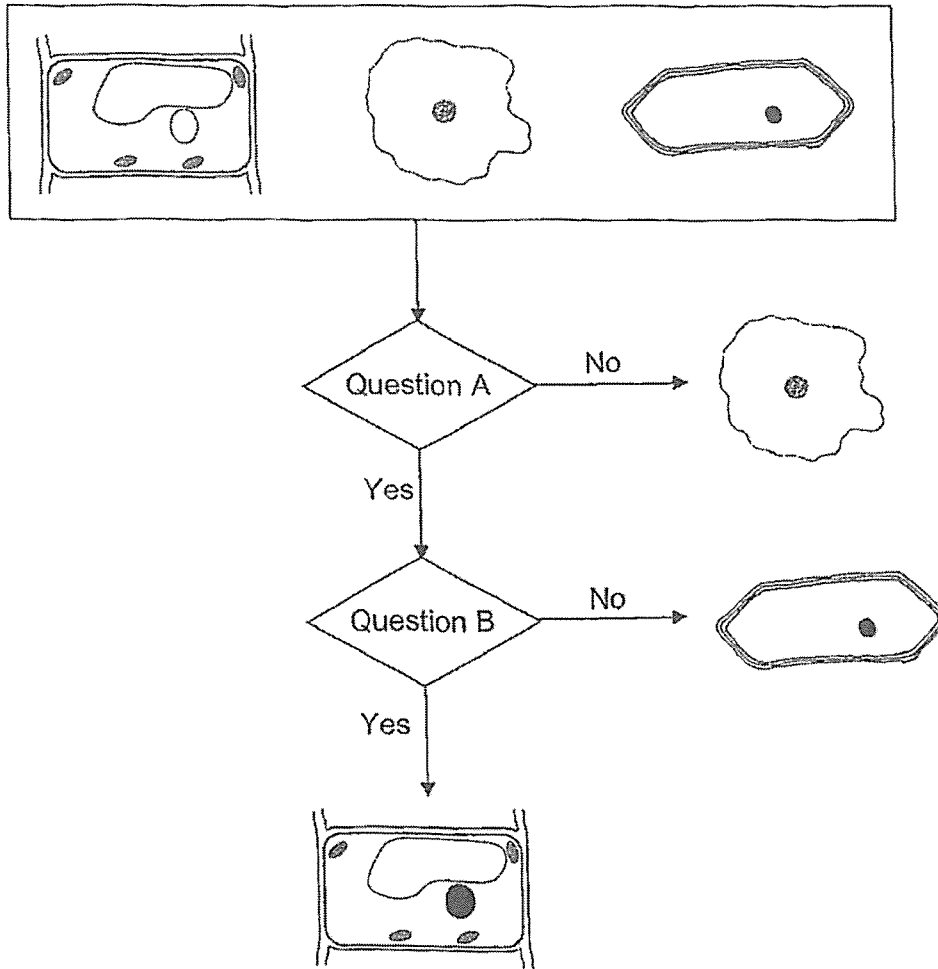

What were the two questions, A and B?

	Question A	Question B
(1)	Is there a cell wall?	Are there chloroplasts?
(2)	Are there chloroplasts?	Is there a cell wall?
(3)	Is there a cell wall?	Is there a cell membrane?
(4)	Is there a cell membrane?	Are there chloroplasts?

11. An experiment was carried out on a stem of a plant as shown below. Two outer rings of the stem were removed at two parts Y and Z. At part Y, the tubes which carry food and water were removed. At part Z, only the tubes carrying food were cut off. The pot of plant was watered regularly.

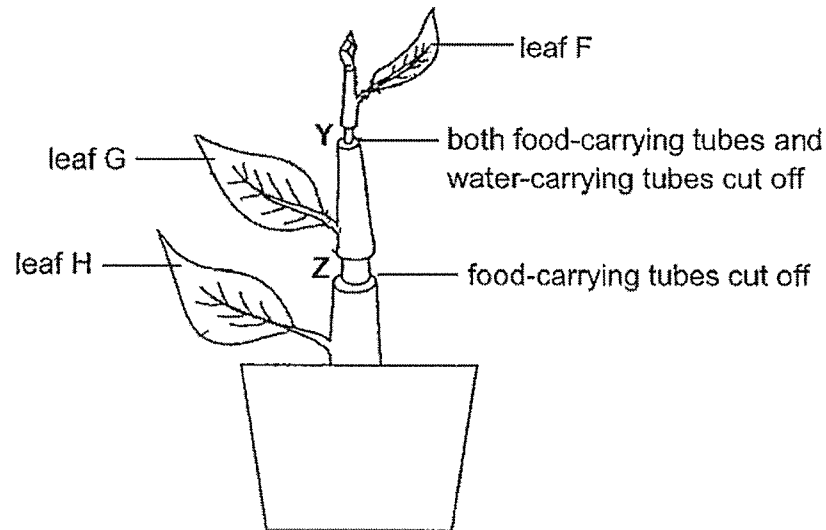

Which of the following statements about this plant, after some time, are correct?

- A. The part above and below the cut at Z would swell.
- B. Leaf F would die but leaf H would continue to grow healthily
- C. The roots would survive and continue to absorb water and mineral salts for the plant.
- D. The food made by leaf H could be transported to the roots and to all parts of the plant above the cut at Z.

- (1) A and B only
- (2) C and D only
- (3) A, B and C only
- (4) B, C and D only

12. The following diagrams show the plant reproductive system and the human reproductive system.

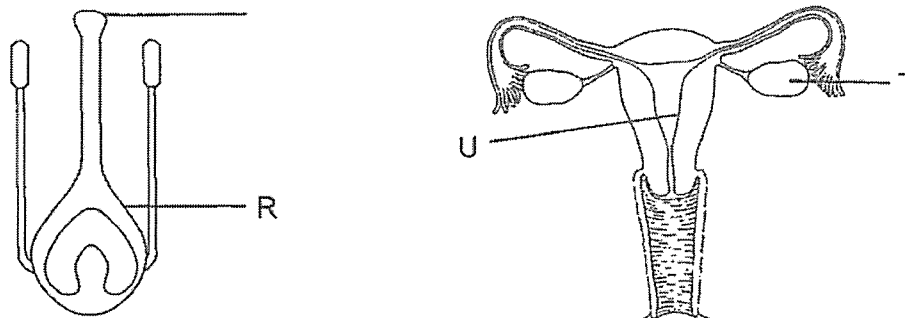

Which of the following statements is correct?

- (1) P and U have the same function.
  - (2) Fertilised egg will develop in R and T.
  - (3) Fertilised egg will develop in R and U.
  - (4) Female reproductive cells are produced in P and T.
13. Hannah conducted an experiment to find out how the size of structure K affects the time the fruit below stays in the air.

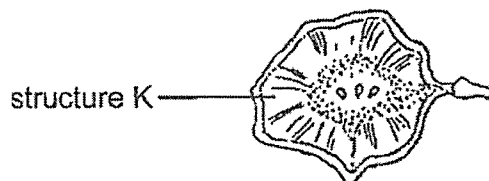

The fruit was dropped from a height above ground three times and the average time taken for the fruit to reach the ground was calculated.

Which of the following shows the changed variable of the experiment and the action she should take before repeating the experiment?

	Changed variable	Action to be taken
(1)	wind speed	switch on a fan
(2)	mass of the fruit	place some weights on the fruit
(3)	size of structure k	cut some parts of structure k away
(4)	time the fruit stays in the air	restart the stopwatch

14. The diagram below shows the life cycle of a mosquito.

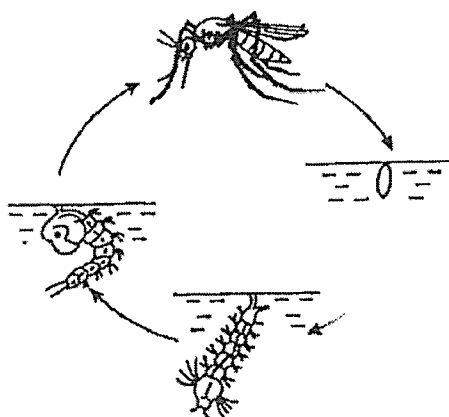

Iman placed an equal number of mosquito eggs into identical containers, A, B, C and D.

The table below shows the different conditions at the start of each experiment.

Container	Type of water	Presence of a layer of oil	Temperature of water (°C)
A	rain water	no	25
B	rain water	no	35
C	pond water	no	35
D	pond water	yes	25

Iman wanted to find out if the temperature of water affects the number of days taken for the eggs to develop into adult mosquitoes.

Which two set-ups should he use to carry out the experiment?

- (1) A and B
- (2) A and C
- (3) B and C
- (4) C and D

15. The diagram below shows a block of potato that was placed into a beaker of digestive juice. The time the potato took to be digested was recorded.

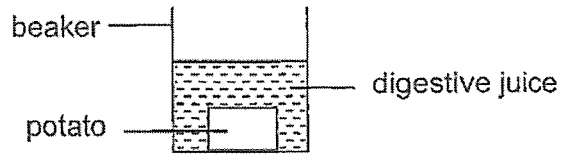

Which of the following would cause the block of potato to be digested within a shorter time?

- (1) use a bigger beaker
  - (2) use a bigger block of potato
  - (3) decrease the amount of digestive juice
  - (4) cut the block of potato into smaller pieces
16. The diagram below shows the water cycle.

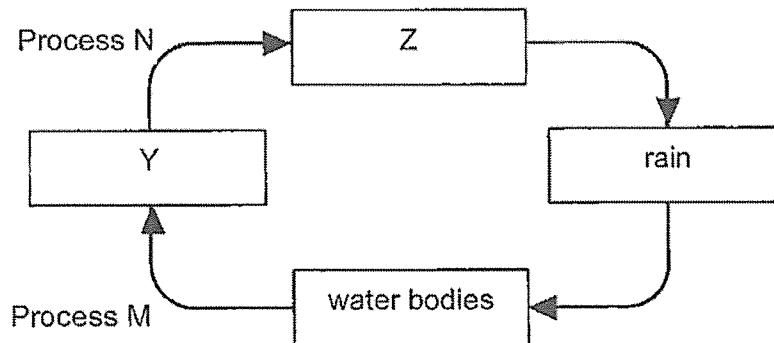

Which of the following statements are correct?

- A. Y represents water vapour. ✓
- B. Water loses heat during process M.
- C. Process N represents condensation. ✓
- D. Z represents the clouds made up of water vapour. ✓

- (1) A and C only
- (2) B and D only
- (3) C and D only
- (4) A, B and C only

17. Alan heated a beaker of ice for some time before turning off the heat. The graph below shows how the temperature of the contents in the beaker changed over time.

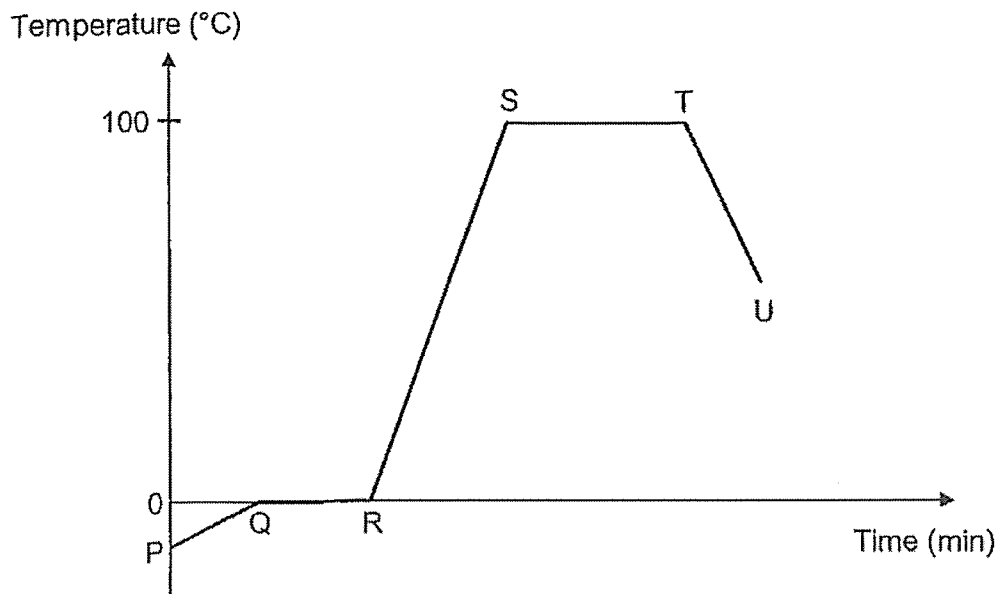

Which of the following statements are correct?

- A. The ice was melting between P and Q.
- B. Water existed in two states between R and S.
- C. Water was gaining heat between S and T.
- D. Water was evaporating between T and U.

- (1) A and B only
- (2) B and C only
- (3) B, C and D only
- (4) A, B, C and D

18. Thomas placed two sticks of solid D in liquid E and connected them to a circuit as shown in the diagram below. The bulb lit up.

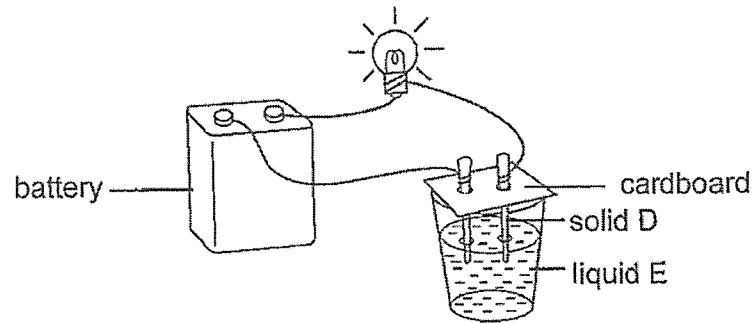

What can Thomas conclude from his observation?

- (1) Only D is an electrical conductor.
  - (2) Only E is an electrical conductor.
  - (3) Both D and E are electrical conductors.
  - (4) Both D and E are not electrical conductors.
19. The diagram shows an electromagnet.

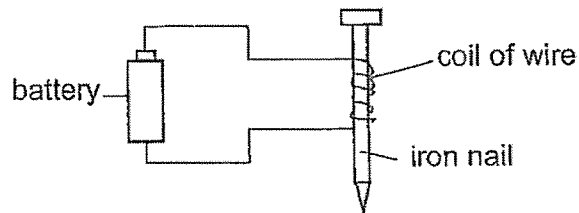

Which action will increase the strength of the electromagnet?

- (1) Increase the length of the wire.
- (2) Decrease the length of the wire.
- (3) Change the direction of the battery.
- (4) Increase the number of coils of wire around the nail.

20. The melting point and boiling point of two substances, X and Y, are shown in the table below.

substance	melting point (°C)	boiling point (°C)
X	40	480
Y	25	350

Which of the following shows the correct state of substances X and Y at 30°C and 420°C?

state of substance X at		state of substance Y at		
30°C	420°C	30°C	420°C	
(1)	liquid	gas	liquid	gas
(2)	liquid	gas	solid	liquid
(3)	solid	gas	solid	gas
(4)	solid	liquid	liquid	gas



21. Four set-ups containing equal amount of water at different temperatures were prepared as shown in the diagrams below. The set-ups were placed in a room of temperature 28°C. The amount of water collected in each of the basins was measured after one hour.

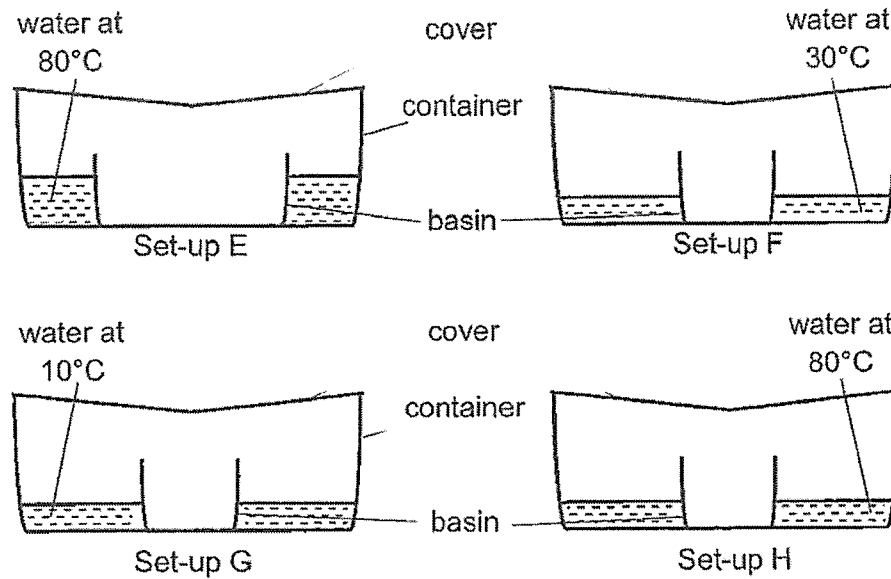

Which of the following statements are correct?

- A. Most amount of water would be collected in set-up H.
- B. Rate of evaporation of water in set-up F was greater than in set-up G.
- C. It is a fair test to compare the amount of water collected in the basins of set-ups E and F.
- D. Water droplets would form slower on the underside of the cover in set-up F than in set-up H.

- (1) A and C only
- (2) B and D only
- (3) A, B and D only
- (4) B, C and D only

22. Study the circuit below.

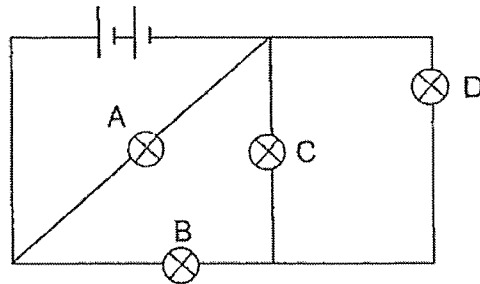

After one of the bulbs had fused, only one bulb remained lit.  
Which bulb, A, B, C or D had fused?

- (1) A
- (2) B
- (3) C
- (4) D

C

23. Three materials, P, Q and R, are connected in the circuit shown below.

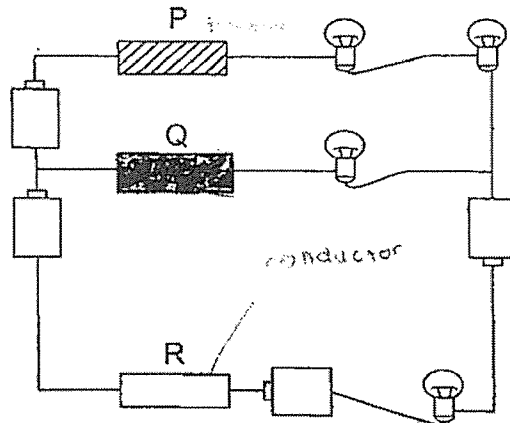

Only two of the light bulbs lit up.

Which one of the following correctly represents materials, P, Q and R?

	Material P	Material Q	Material R
(1)	steel	plastic	wood
(2)	plastic	wood	rubber
(3)	iron	ceramic	steel
(4)	wood	silver	copper

24. A set-up was prepared as shown below.

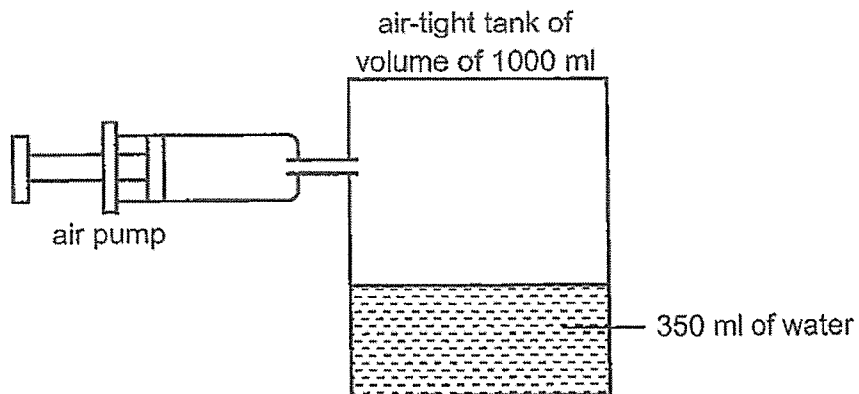

After five more pumps of air was introduced into the tank, which of the following would happen to the air and the water in the tank?

	Volume of air	Mass of air	Volume of water
(1)	increased	increased	decreased
(2)	remained the same	remained the same	remained the same
(3)	increased	remained the same	decreased
(4)	remained the same	increased	remained the same

25. The following experiment was conducted in a dark room.

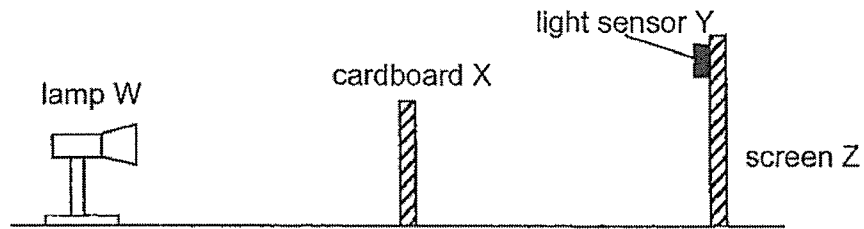

One of the objects in the set-up was moved. The graph below shows how the reading on Y changed over time.

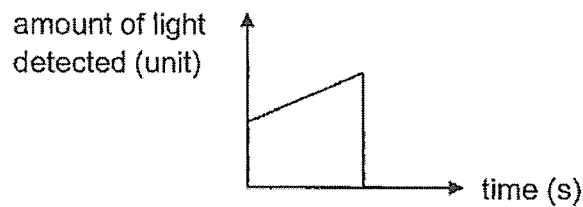

Based on the given information, which object was moved and in which direction?

- (1) screen Z away from lamp W ✓
- (2) lamp W towards cardboard X
- (3) cardboard X towards screen Z
- (4) lamp W away from cardboard X

26. Hot water is poured into a metal cup. It is too hot to hold the cup at part B but the cup can be held at part A instead.

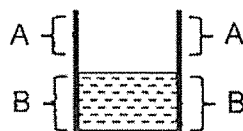

Which of the following best explains why the cup can be held at part A but not at part B?

- (1) Part B has a lower melting point.
- (2) Part A is a poorer conductor of heat. ✓
- (3) Part B can expand faster than part A.
- (4) Part A is further from the heat source.

27. Different amounts of water at room temperature were poured into two identical containers, F and G. The containers of water were then heated until the water boiled.

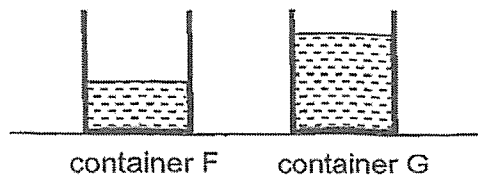

The temperatures of water in F and G were recorded every minute for some time. Which of the following is the correct graph for the results?

(1)

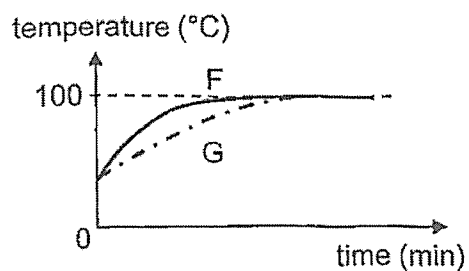

(2)

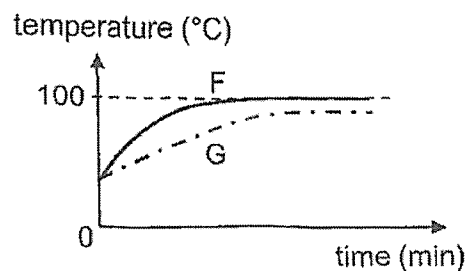

(3)

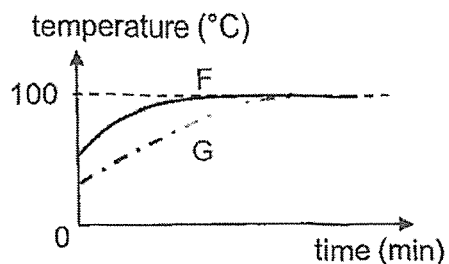

(4)

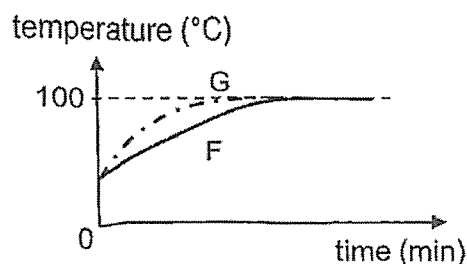

28. The diagram below shows apples placed in a container with holes. When this heavy container of apples is placed under a running tap, water flows out through the holes.

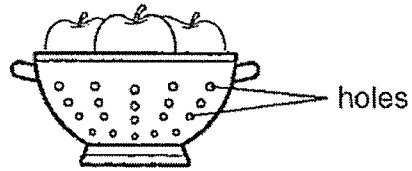

Based on the information, which material is most suitable for making the container?

	Material	Property	
		strong	waterproof
(1)	A	x	x
(2)	B	x	✓
(3)	C	✓	x
(4)	D	✓	✓

Key
✓ : yes
x : no

END OF BOOKLET A

GO ON TO BOOKLET B

**BOOKLET B : [44 marks]**

For questions 29 to 40, write your answers in this booklet.

The number of marks available is shown in the brackets [ ] at the end of each question or part-question.

29. John's average heart rate is 80 beats per minute when he is resting. The graph below shows his heart rate over a period of 60 minutes when he was at a park.

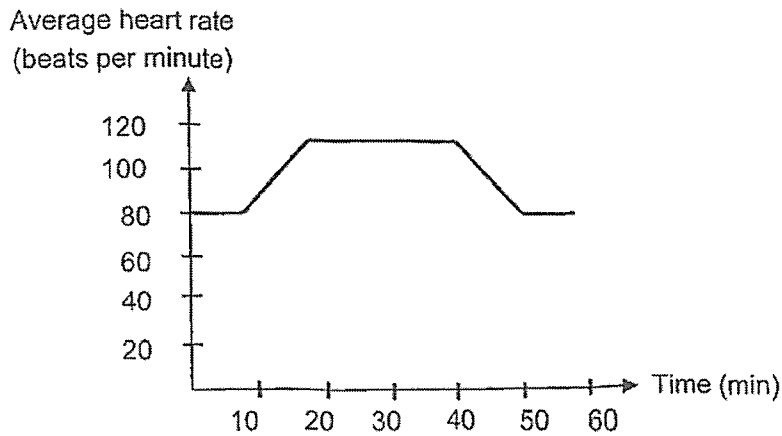

- (a) John started jogging after 10 minutes.  
Explain why his heart rate increased between 10<sup>th</sup> and 20<sup>th</sup> minute. [2]

\_\_\_\_\_ *breath* \_\_\_\_\_

- (b) State two functions of the small intestine. [1]

\_\_\_\_\_

- (c) Between 20<sup>th</sup> and 40<sup>th</sup> minute, less blood was transported to the small intestine during jogging as compared to resting.  
Explain how this affected one function of the small intestine. [1]

\_\_\_\_\_

to release

Marks :

/ 4

30. Four plants were placed in identical jars, each containing water at the same height of 30 cm and a layer of oil as shown in the diagram below. The four set-ups W, X, Y and Z were placed next to the window for two hours.

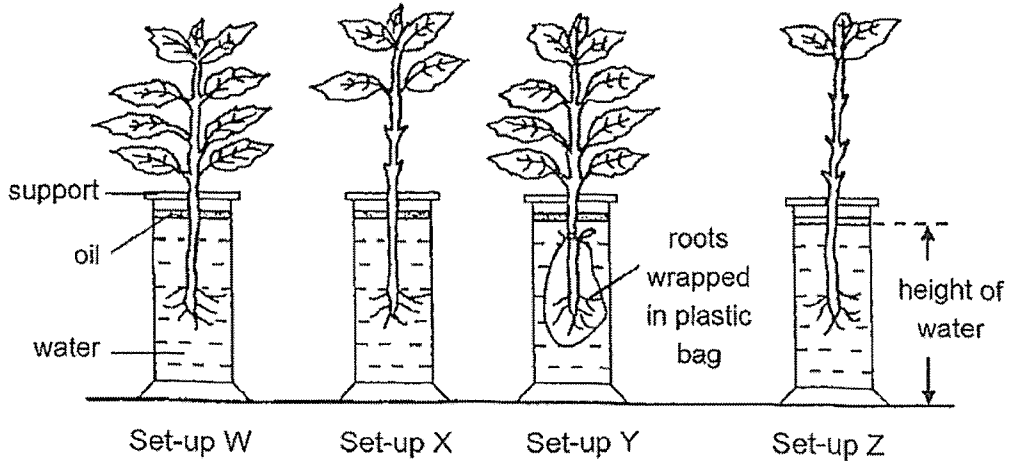

The table below shows the height of the water in each jar at the end of the experiment.

Set-up	Height of water (cm)
W	26.0
X	27.5
Y	30.0
Z	29.0

- (a) Based on the experiment, explain the relationship between the number of leaves of the plant and the amount of water left at the end of the experiment. [2]

leaves

---



---



---

roots are

---

Marks : / 2



30. (b) How did adding a layer of oil in each set-up make the experiment a fair test? [1]

---

---

(c) By comparing set-ups W and Y, explain how the results of set-up Y enable us to conclude about the function of the roots. [1]

some

---

---

31. The diagram below shows a process in the reproduction of humans.

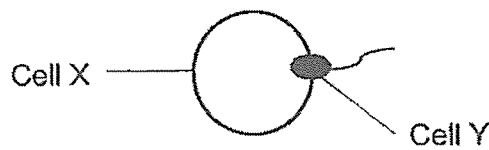

(a) Identify Cell X and Cell Y. [1]

Cell X: \_\_\_\_\_

Cell Y: \_\_\_\_\_

(b) What is the process shown above and state how the process takes place. [2]

---

---

Marks : 

/ 5
-----



32. The diagram below shows fruit G.

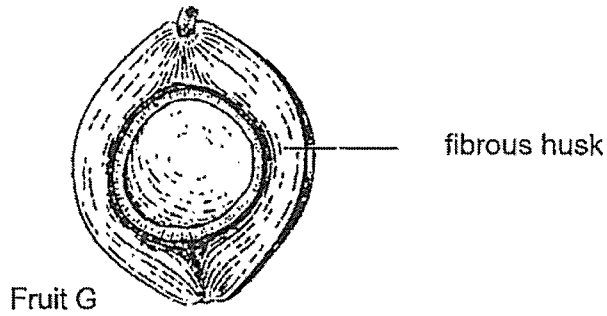

(a) (i) Explain how the fibrous husk helps fruit G with its dispersal. [1]

\_\_\_\_\_ the \_\_\_\_\_

(ii) State a characteristic of the outer covering of fruit G that helps in its dispersal. [1]

\_\_\_\_\_

(b) Study the map below.

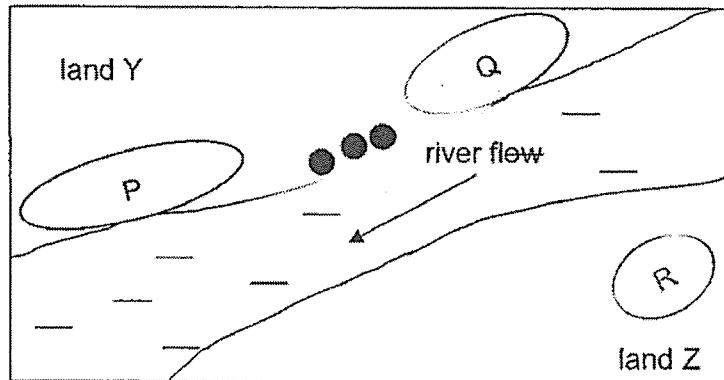

Key  
● : adult plant of fruit G

In which area, P, Q or R, will the young plants of fruit G be growing after some time? Explain your answer. [1]

\_\_\_\_\_ follows

\_\_\_\_\_

Marks :  / 3

33. Jonathon took some ice cubes from the freezer and placed them on the table. He noticed a 'white cloud' forming above the ice cubes.

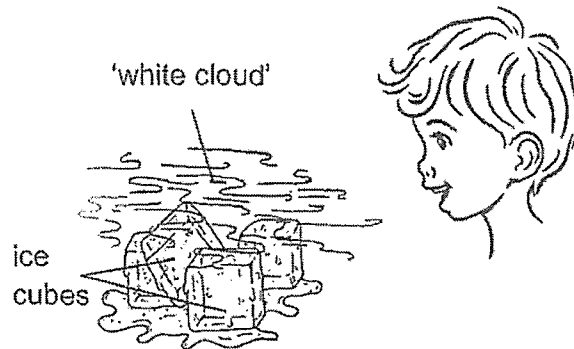

- (a) Name the process that caused the 'white cloud' to form. [1]

Process : \_\_\_\_\_

- (b) Explain how the 'white cloud' was formed above the ice cubes. [2]

Some ice

---



---



---

Jonathon then boiled water in a kettle and he noticed a 'white cloud' forming above the spout of the kettle.

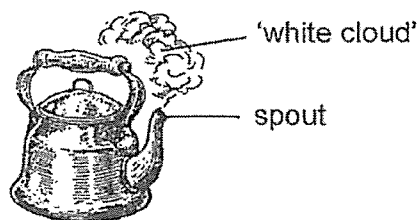

- (c) State one difference between the temperature of the water vapour that changed into the 'white cloud' above the spout of the kettle and above the ice cubes. [1]

---



---

Marks :

/ 4

34. Antonio wanted to find out how blowing an electric fan at a bowl of water would affect the rate of evaporation of the water. He prepared two set-ups as shown below.

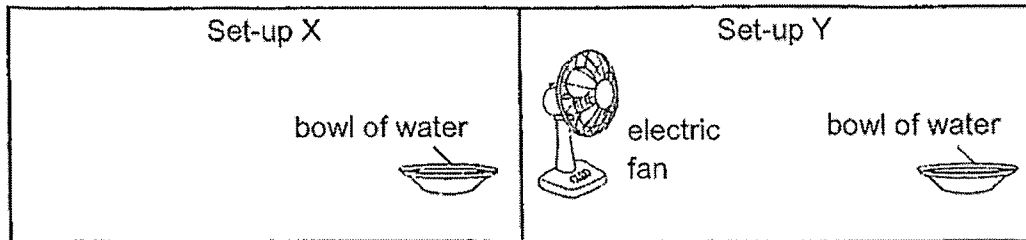

- (a) State one variable that should be kept constant to make his experiment a fair test. [1]

It was a very hot day. Antonio wanted to cool a small room which has no window. He placed a big piece of wet cloth over a wall-mounted hanger in the room and blew an electric fan at it as shown in the diagram below.

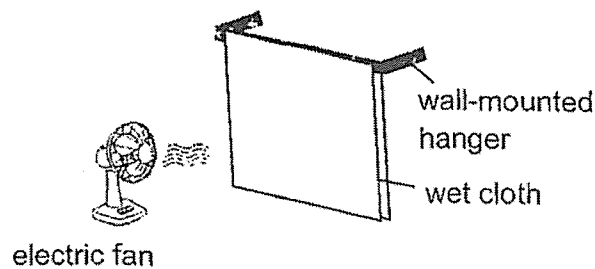

- (b) Explain how each of the following would cause the temperature of the small room to decrease. [2]

(i) wet cloth

---



---

(ii) electric fan

---



---

Marks :

1 / 3
-------

35. Study the set-up below.

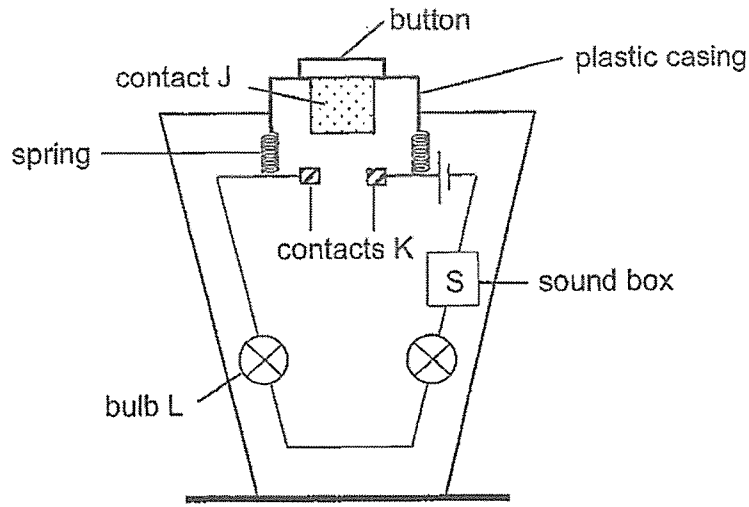

When the button is pressed, the set-up gives off light and produces a sound.

(a) State a property of contacts J and K must have for the set-up to work. [1]

\_\_\_\_\_ K are both electrical cond. [1]

(b) Describe how the set-up produces light and sound when the button is pressed. [2]

\_\_\_\_\_

\_\_\_\_\_

\_\_\_\_\_

\_\_\_\_\_

(c) After some time, bulb L stopped working. What could be observed about the set-up after the button is pressed? Explain your answer. [1]

\_\_\_\_\_

\_\_\_\_\_ even

Marks : 

4
---

36. (a) State what a matter is. [1]

is something and occupies

(b) Study the chart below.

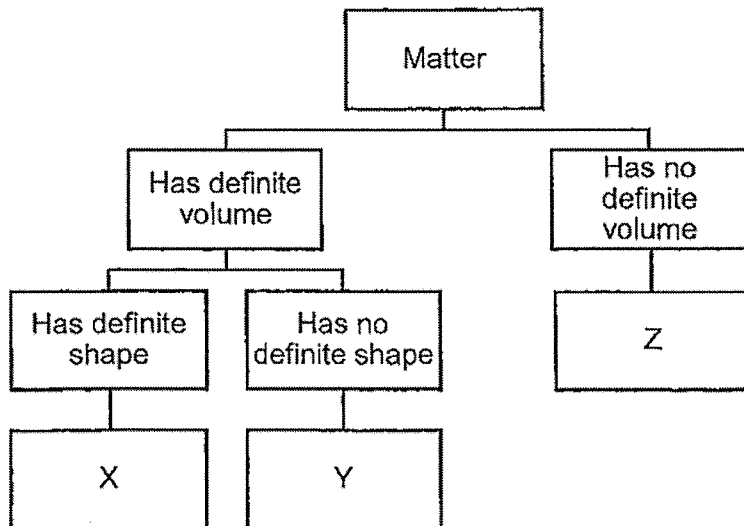

Which of the letters, X, Y or Z, represent the following matter? [1]

(i) ice cubes : \_\_\_\_\_

(ii) oxygen : \_\_\_\_\_



(c) The diagram shows a block of sponge and a wooden block of the same size.



sponge



wooden block



plastic container

The sponge can be fitted inside the plastic container, but the wooden block cannot. Explain this observation. [2]

does not have a definite shape and  
 occupies a certain extent as there are  
 irregular and square

Marks :  / 4

37. Jonathan set up a light source and a light sensor to find out how fast a fan turns as shown below.

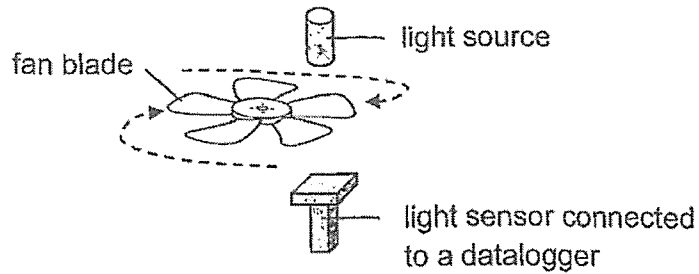

The graph below shows the results after the fan was turned for some time.

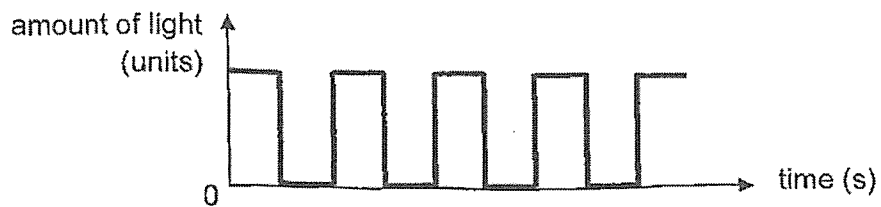

- (a) Based on the graph, were the fan blades made of clear plastic or metal? Explain your answer. [1]

allow

- (b) Based on the above results, did the fan make one complete turn? Explain your answer. [1]

a

- (c) State the difference in the results of one fan blade if the fan turns slower instead. [1]

Marks : / 3

38. (a) Joshua placed his hand on a sheet of metal and his hand felt cool. Explain Joshua's observation. [1]

is a

---

---

- (b) Joshua set up an experiment to find out if the presence of a metal sheet affects how fast ice melts.

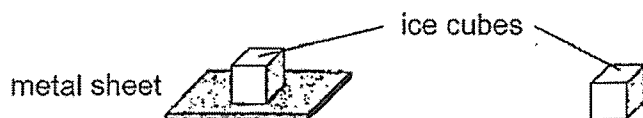

Joshua observed that the ice cube placed on the metal sheet took a shorter time to melt completely.

Explain how the metal sheet caused the ice cube to melt faster. [1]

is

---

---

Marks : 

/ 2
-----



- (c) Joshua conducted another experiment to find out how well different materials conduct heat.

He placed an ice cube on a sheet made of material F. He measured the time taken for the ice cube to melt completely. He repeated the experiment with sheets made of materials G and H.

The graph below shows his results of the experiment.

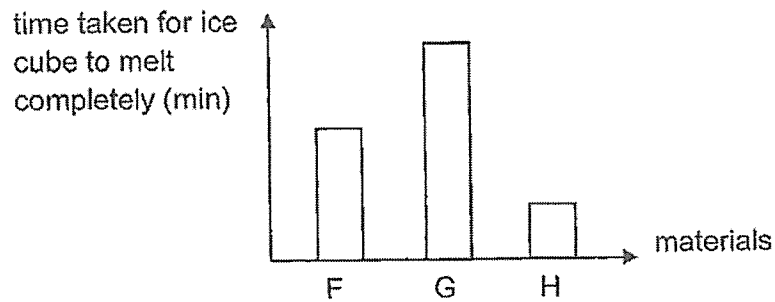

- (i) Explain how using thicker sheets may affect the results of the experiment. [1]

---

---

- (ii) Joshua wants to make a container that can keep his food warm for as long as possible.

Based on the graph, which material, F, G or H is most suitable to make the container? Explain your answer. [2]

---

---

---

Marks :

1	/ 3
---	-----

39. Ravi used three magnets, W, X and Y to create a swinging ball.

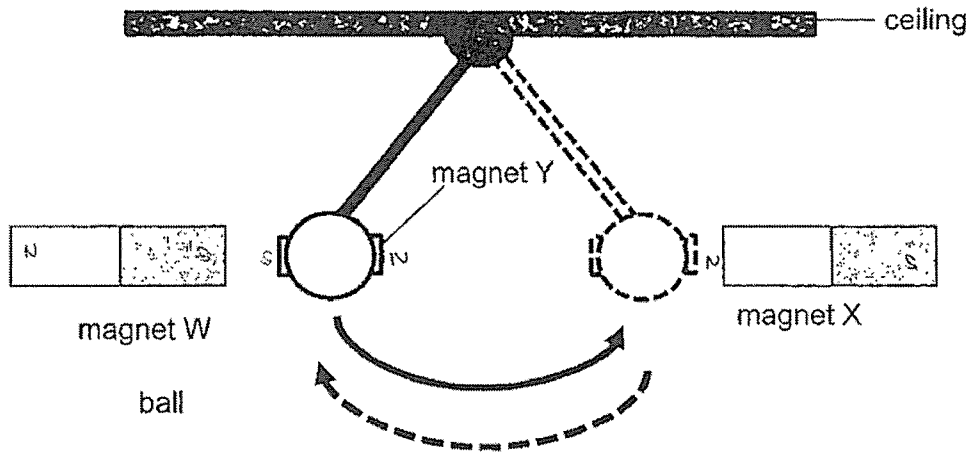

He brought the ball with magnet Y attached to it near magnet W and released it. The ball swung away from magnet W and moved towards magnet X. When the ball was near magnet X, it swung back towards magnet W.

(a) State a material magnets W, X and Y can be made of. [1]

---

(b) Ravi observed that the ball swung back and forth repeatedly without stopping. Explain his observation. [2]

---

---

---

Marks : 

/ 3
-----

40. Hui Ling conducted an experiment to compare a property of two equally long strips, P and Q, which are made of different materials. She inserted a metal hook into each strip and hung a 100g-weight onto each hook as shown below.

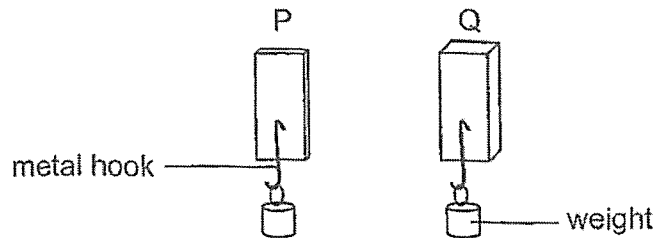

Both hooks slid downwards and tore the strips as soon as the weights were placed onto the hooks.

- (a) Which property of the strip was Hui Ling trying to compare? [1]

---

- (b) Hui Ling's experiment was not a fair test. Suggest one change to her set-up so that her experiment would be a fair test. [1]

---

---

- (c) Hui Ling repeated the experiment with a new piece of strip P and the result remained the same.

- (i) Give a reason why using only one 100g-weight caused the results to be inaccurate. [1]

---

---

- (ii) Suggest one way to make the results of the experiment to be more accurate for comparison. [1]

---

---

Marks : 

/ 4
-----

~ END OF PAPER ~

This is the property of Maha Bodhi School.

No part of this should be duplicated without the permission of the school.



SCHOOL : MAHA BODHI PRIMARY SCHOOL  
 LEVEL : PRIMARY 5  
 SUBJECT : SCIENCE  
 TERM : 2024 SA2

Q1	Q2	Q3	Q4	Q5	Q6	Q7	Q8	Q9	Q10
2	3	2	3	4	1	3	3	4	1
Q11	Q12	Q13	Q14	Q15	Q16	Q17	Q18	Q19	Q20
3	3	3	1	4	1	3	3	4	4
Q21	Q22	Q23	Q24	Q25	Q26	Q27	Q28		
3	2	4	4	2	4	1	4		

PAPER 2

Q29)	<p>a) He needs more energy when exercising. The heart rate increased to pump more blood rich in oxygen and digested food to all parts of the body faster.</p> <p>b) Digest food. Absorb digested food into the bloodstream.</p> <p>c) Less digested food is absorbed into the bloodstream.</p>
Q30)	<p>a) As the number of leaves increase, the amount of water left decrease. More water was absorbed for the leaves to make food.</p> <p>b) To prevent the water from evaporating.</p> <p>c) The height of the water remained unchanged. The roots in Y could not absorb water.</p>
Q31)	<p>a) Cell X: egg sell Cell Y: sperm</p> <p>b) Fertilisation. The sperm cell fuses with the egg cell.</p>

Q32)	<p>a) i) The fibrous husk trap air to help the fruit float on water. ii) Waterproof</p> <p>b) P. The fruit will follow the direction of the river flow.</p>
Q33)	<p>a) condensation</p> <p>b) The air around the ice cubes lost heat to the ice cube. Water vapour in the surrounding touch the cool air. The water vapour lost heat and condensed into water droplets.</p> <p>c) The water vapour about the spot is hotter than the water vapour above the ice cube.</p>
Q34)	<p>a) The amount of water.</p> <p>b) i) Water in the wet cloth is gaining heat from the air to evaporate. ii) Wind from the fan will increase the rate of evaporation of the water on the cloth.</p>
Q35)	<p>a) Conductor of electricity.</p> <p>b) J touches contacts K and the circuit is closed Electric current flows through the bulb and the sound box.</p> <p>c) There is no light and sound. The circuit is open.</p>
Q36)	<p>a) Anything that has mass and occupy space.</p> <p>b) i) X ii) Z</p> <p>c) The sponge has air that can be compressed. The wooden block cannot be compressed.</p>
Q37)	<p>a) Metal. No light was detected at some parts. The blade does not allow light to pass through.</p> <p>b) No. There are 5 blade but the sensor was only blocked 4 times.</p> <p>c) The light is blocked for a longer time. The light is unblocked for a longer time.</p>
Q38)	<p>a) His hand lost heat to the sheet.</p> <p>b) The sheet conducted heat from the surrounding to the ice cube faster.</p> <p>c) i) More time is needed for the heat to pass through the material. ii) G. Time taken for the ice cube to melt is the longest. Heat flow the food will be lost to surrounding the slowest.</p>
Q39)	<p>a) Steel.</p> <p>b) When magnet Y is near W, their like poles were facing each other Y is repelled and moved towards X. When Y is near X, the like poles were facing each other. Y is repelled and move back to W.</p>

Q40)	<ul style="list-style-type: none"><li>a) Strength.</li><li>b) Make the thickness the same.</li><li>c) <ul style="list-style-type: none"><li>i)The material may take less than 100g to tear.</li><li>ii)Use lighter weight. Hang them one at a time until the material tears.</li></ul></li></ul>
------	--

