

St Hilda's Primary School

P4 Term 1 Science Unweighted Assessment 2024

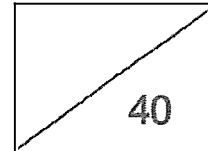

Name: _____

Date: _____

Class: P4 _____

Parent's Signature: _____

Duration: 50 mins

Topics: Human System, Matter

1. The structures below are grouped according to the body systems that they belong to. Which one has been placed incorrectly?

Digestive system	Skeletal system	Circulatory system
Lungs	Skull	Heart
Gullet	Backbone	Blood in blood vessels

- 1) Skull
- 2) Lungs
- 3) Backbone
- 4) Heart

()

2. Which of the following systems work together to help Fiona run?



- A. Respiratory system
- B. Circulatory system
- C. Muscular system
- D. Skeletal system ✓

- 1) A and B only
- 2) C and D only
- 3) A, C and D only
- 4) A, B, C and D

()

3. Which one of the following systems delivers digested food and oxygen to all parts of the body?

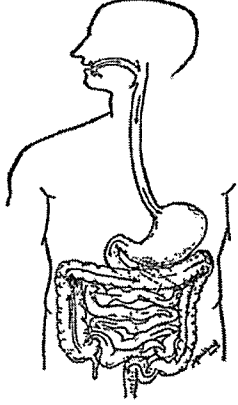
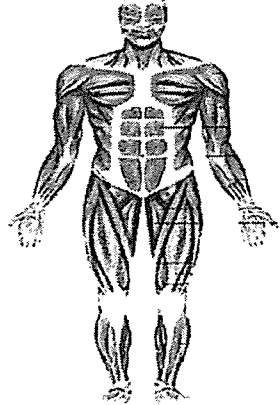
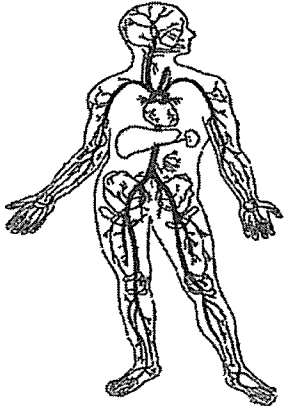
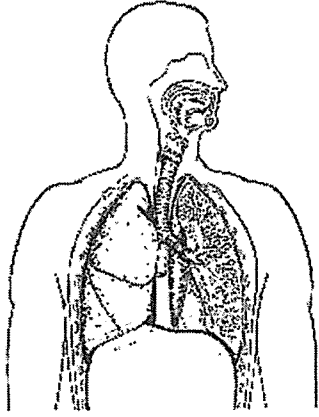
 <p>1) Digestive System</p>	 <p>2) Muscular System</p>
 <p>3) Circulatory System</p>	 <p>4) Respiratory System</p>

()

4. Digestion takes place at the _____.

- A: Mouth
- B: Gullet
- C: Stomach
- D: Small intestine
- E: Large intestine

- 1) C and D only
- 2) A, C and D only
- 3) B, C and D only
- 4) B, D and E only

(

5. Which of the following functions does not match with the human body system?

	System	Function
(1)	Skeletal	supports the body
(2)	Muscular	protects our vital organs
(3)	Respiratory	removes air from the body
(4)	Digestive	breaks down our food into simple substances

()

6. Study the diagram below.

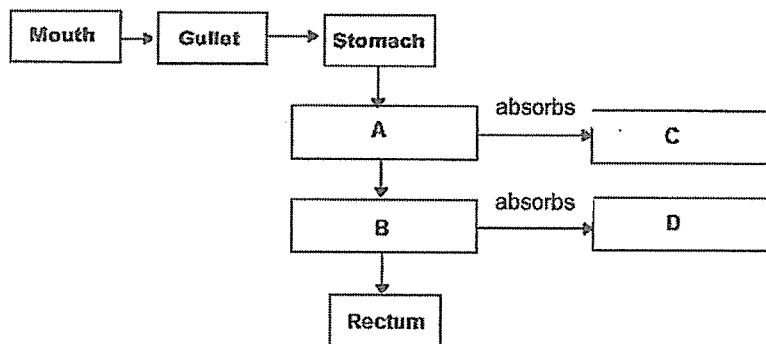

Which of the following is correct?

	A	B	C	D
1)	Small intestine	Large intestine	Digested food	Water
2)	Large intestine	Small intestine	Water	Digested food
3)	Small intestine	Large intestine	Water	Undigested food
4)	Large intestine	Small intestine	Undigested food	Water

()

7. A syringe is filled with an equal volume of air and water. The nozzle of the syringe is covered tightly by a finger as shown below.

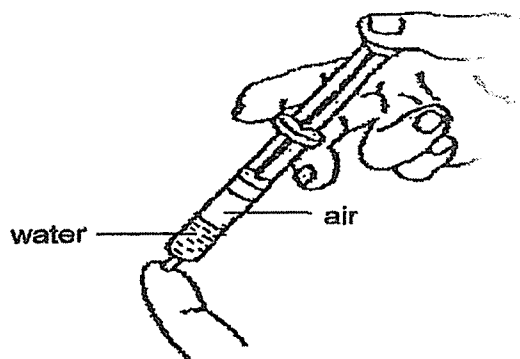

Which of the following is true when the plunger is pushed in?

	Volume of Air	Volume of Water
1	Decrease	Decrease
2	Decrease	No Change
3	No Change	Decrease
4	No Change	No Change

()

8. Study the table below. Which object is not ticked correctly?

√ means "has that property", X means "does not have that property".

Objects	Definite Shape	Definite Volume
Small Pebbles		
Oxygen		X
Milk	X	
Pen		

- 1) Milk
- 2) Pen
- 3) Oxygen
- 4) Small Pebbles

()

9. Karen placed Object A into a beaker of 150 cm^3 of water. The water level then rose to 300 cm^3 .

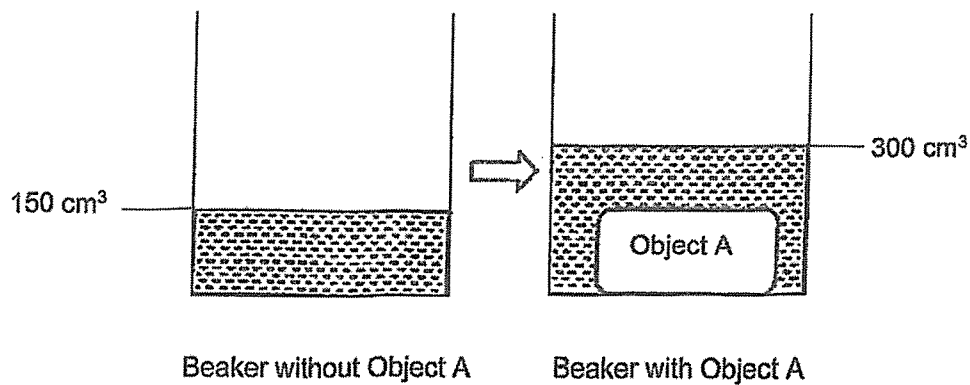

She removed Object A and cut it into two separate pieces. The diagram below shows the water level when she placed the two cut pieces of Object A back into the beaker.

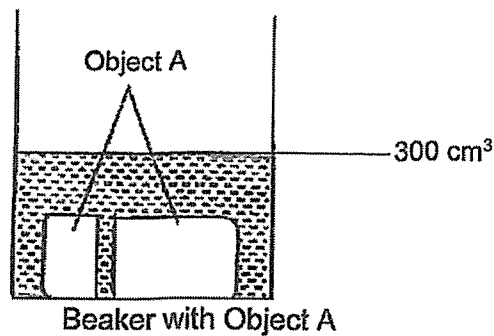

From the above observation, what can Karen conclude about the properties of Object A?

- A) Has mass ✓
- B) Can be compressed
- C) Has definite volume
- D) Has no definite volume

- 1) C only
- 2) A and B only
- 3) B and D only
- 4) All of the above

()

10. Study the diagram shown below.

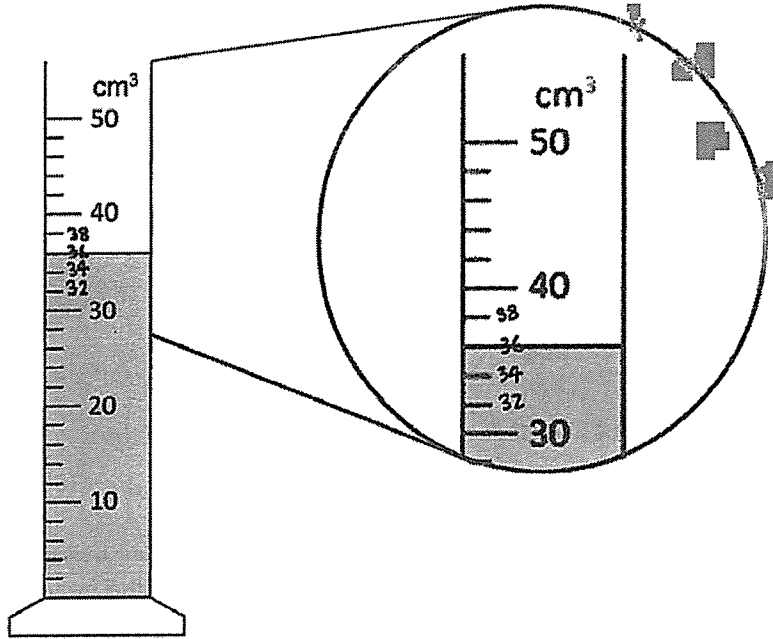

What is the volume of the liquid shown above?

- 1) 33 cm³
- 2) 35 cm³
- 3) 36 cm³
- 4) 38 cm³

()

11. When more air is pumped into a volley ball as shown in the diagram below, it does not get any bigger.

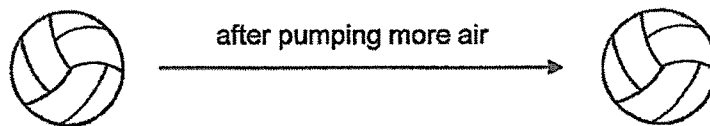

Which one of the following property of air does the above diagram show?

This shows that air _____.

- 1) has mass
- 2) has volume
- 3) can be compressed
- 4) does not occupy space

()

12. Which one of the following diagrams shows the correct water level in the container when the container is placed on the table after awhile?

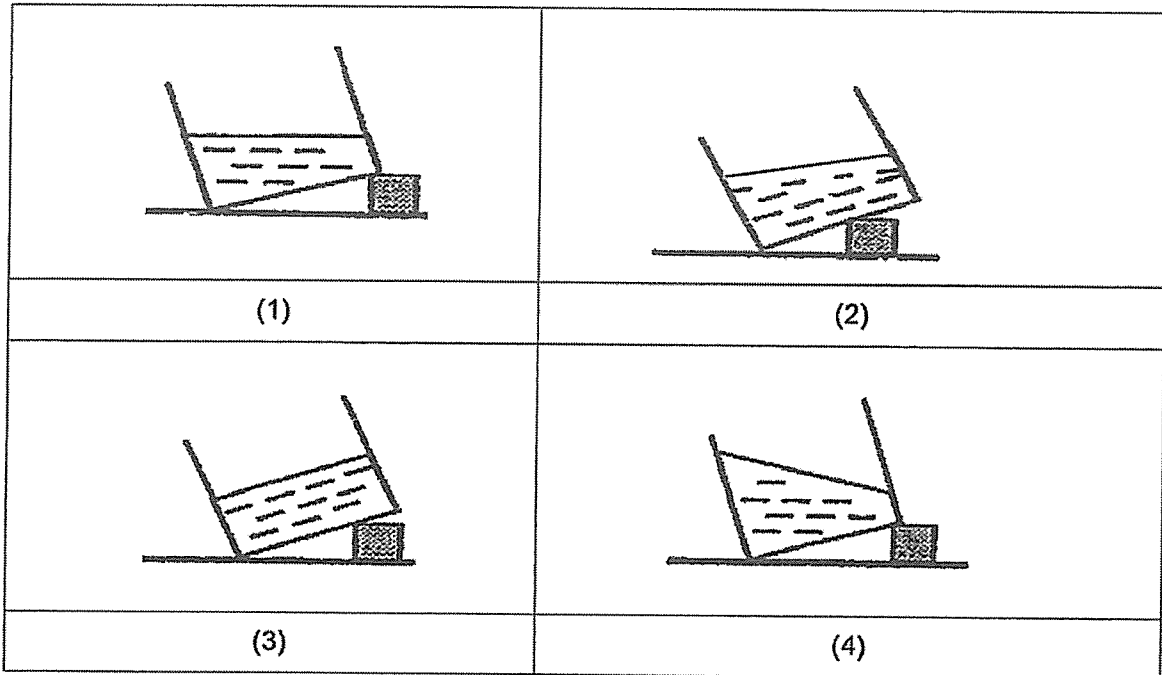

()

End of Booklet A

13. Study the diagram below and answer Questions 13 (a) and (b).

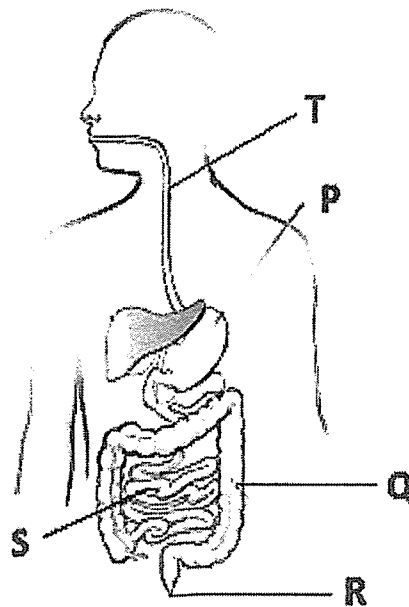

(a) Write the parts, P, Q, R, S and T in the blanks below to match them with the descriptions stated. (2m)

	Parts
Digested food enters the blood stream.	
Water is removed from the undigested food here.	
The muscle contracts to churn food and produces digestive juices to break them down into simple substances.	
Undigested food leaves the body here.	

(b) Mr George is eighty years old and he has lost some of his tooth due to his old age. His doctor has advised him to cut his food into smaller pieces when consuming food. Explain how this helps him in the digestion of his food. (2m)

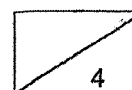

14. Daniel crushed a piece of biscuit 10 times and placed it into a glass container containing some digestive juice as shown in the diagram below.

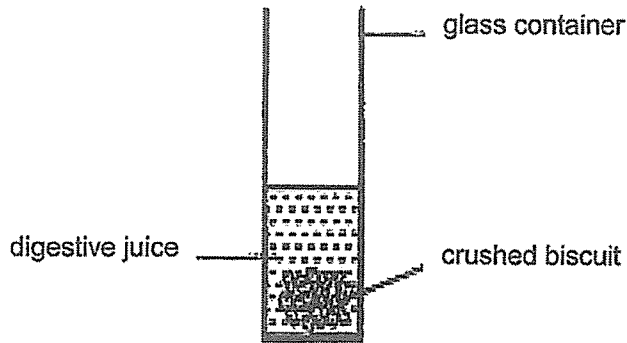

He repeated the same process for another 3 pieces of similar biscuits, each crushed for a different number of times. He recorded the time taken for the biscuits to be completely broken down into simpler substances.

Mass of the biscuit (grams)	20	20	20	20
Number of times the biscuit was crushed	10	15	20	25
Time taken for the biscuit to be completely broken down into simpler substances (minutes)	48	44	35	29

- (a) Besides those stated above, what is **one** more variable that Daniel must keep the same in order to make the experiment a fair test? (1m)

- (b) Based on the information in the table above, what is the relationship between the number of times a piece of biscuit is crushed and the time taken for it to be completely broken down into simpler substances? (1m)

- (c) What is the aim of Daniel's experiment? (1m)

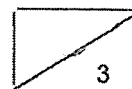

15. Study the classification chart below.

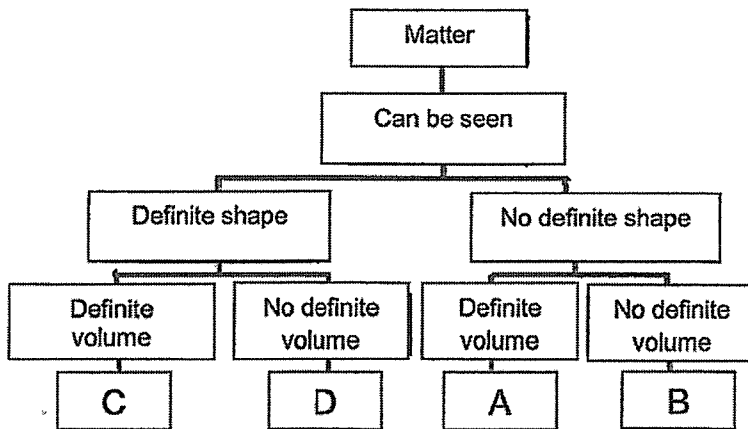

(a) Based on the classification chart above, state two characteristics of matter C. (1m)

(b) What is the state of matter found in A and give an example of A. (1m)

16. A measuring cylinder was packed with pebbles to the 50cm³ mark. 300 cm³ of water was added but the water level did not reach the 350cm³.

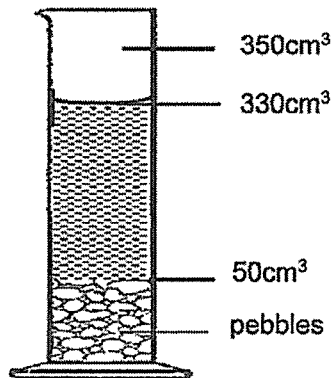

(a) Explain why the water level did not reach 350cm³. (1m)

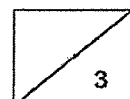

(b) In the diagram below, Ariel stuck a piece of dry tissue in a cup. She cut hole X in a corner of the cup. She then inverted the cup and pushed it directly into a trough of water.

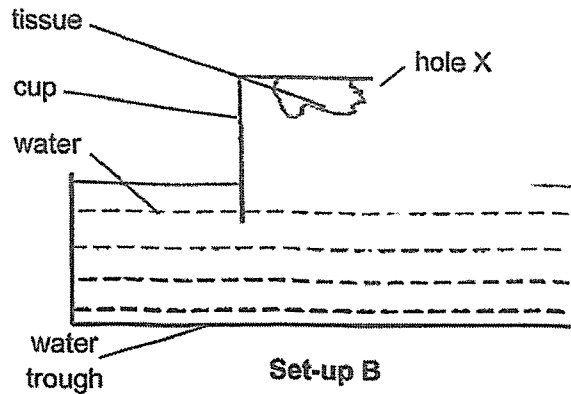

Will the tissue paper remain dry? Explain why.

(1m)

17. Florence conducted the experiment as shown below.

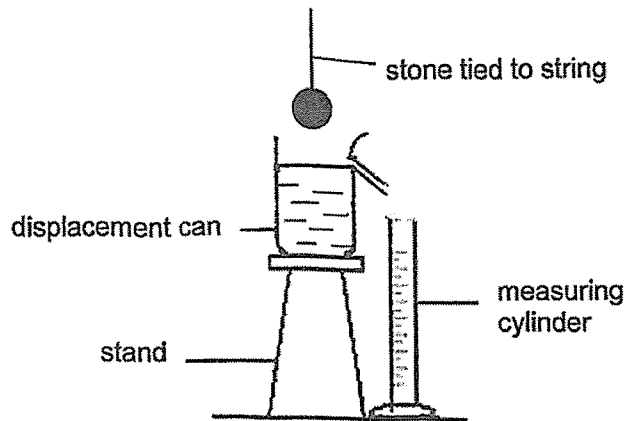

(a) What would happen when the stone was lowered into the above displacement can that was filled with water?

(1m)

(b) Fill in the blank with the correct answer.

(1m)

In the above experiment, Florence measured the _____ of the stone.

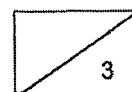

18. Billy prepared 3 set-ups A, B and C as shown below. He then poured 200 ml of water into each funnel at the same time with help from his classmates. He observed the time taken for the water to flow into the flask.

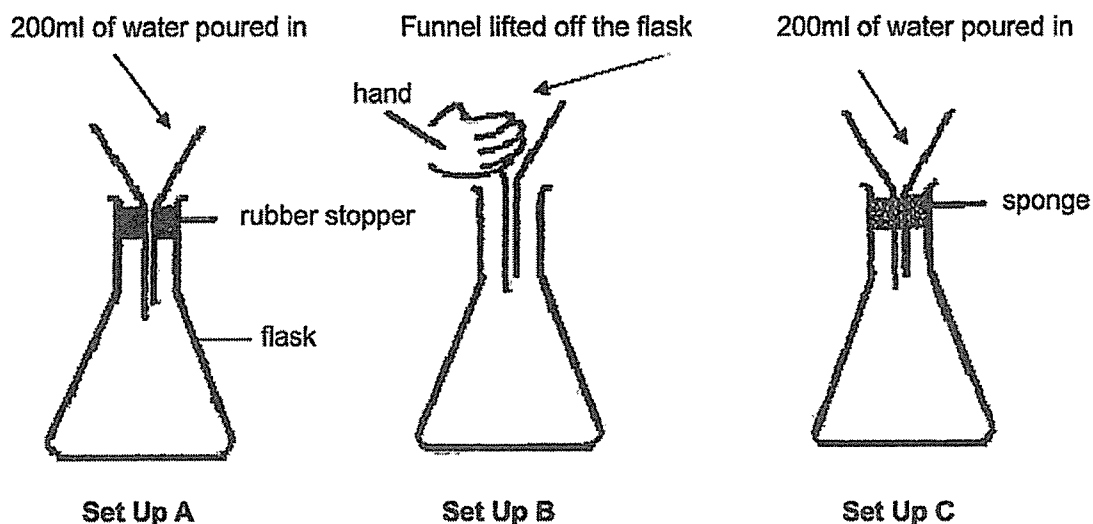

(a) Arrange in ascending order how fast water would flow through the funnel from the slowest to the fastest in the boxes below using letters A, B and C only. (1m)

Slowest	→	Fastest

(b) Water flowed the least into one of the set ups. Which set up is this? Explain your answer. (2m)

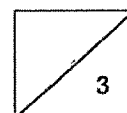

End of Booklet B

SCHOOL : ST.HILDA'S SCHOOL
 LEVEL : PRIMARY 4
 SUBJECT : SCIENCE
 TERM : 2024 WA1

Q1)	2
Q2)	4
Q3)	3
Q4)	2
Q5)	2
Q6)	1
Q7)	2
Q8)	3
Q9)	1
Q10)	3
Q11)	3
Q12)	1
Q13)	a) S, Q, P, R b) Cutting the food increases the surface area exposed to the digestive juice. This speeds up digestion.
Q14)	a) The amount of digestive juices in the glass container. b) The relationship between the number of times crushed and the time taken is that the more times crushed the less time is taken for the biscuit too be completely broken down into simpler substances. c) The aim of the experiment is to find out if the size of the biscuit can affect the rate of digestion.
Q15)	a) Matter C has a definite shape and volume . b) Liquid is the state of matter found in A and A might be water.
Q16)	a) Air between the pebbles escapes and allows water to occupy the air spaces. b) Air could escape from hole X and allows the water to fill the sup fully.
Q17)	a) Some water will go into the measuring cylinder. b) volume
Q18)	a) Set-up A / Set-up C / Set-up B b) Air occupies space in the flask and air cannot escape.

