



MAHA BODHI SCHOOL
2024 END OF YEAR EXAMINATION
PRIMARY FOUR SCIENCE
(BOOKLET A)

Name : _____ ()

Class : Primary 4 _____

Date : 24 Oct 2024

Total Duration for Booklets A and B: 1 h 45 min

INSTRUCTIONS TO CANDIDATES:

1. Do not turn over this page until you are told to do so.
2. Follow all instructions carefully.
3. Answer all questions.
4. Shade your answers in the Optical Answer Sheet (OAS) provided.

This booklet consists of 16 printed pages.

BLANK PAGE

BOOKLET A : [28 x 2 marks = 56 marks]

For each question from 1 to 30, four options are given. One of them is the correct answer. Make your choice (1, 2, 3 or 4) and **shade your answer on the Optical Answer Sheet provided.**

1. Which of the following is not a source of heat?

- (1) Sun
- (2) lighted bulb
- (3) candle flame
- (4) woolen jacket

2. Water at 80 °C is mixed with water at 10 °C.

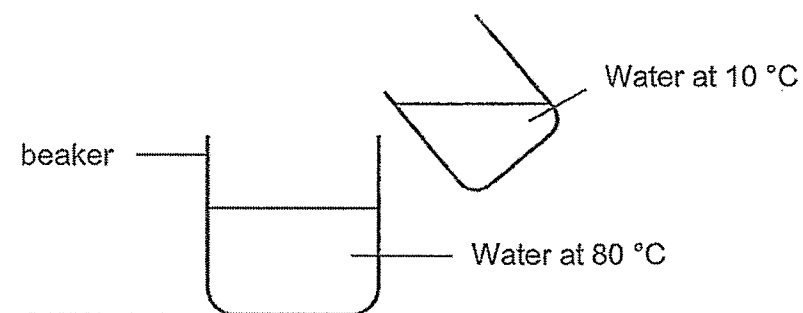

What is a possible final temperature of water in the beaker?

- (1) 10 °C
- (2) 45 °C
- (3) 80 °C
- (4) 90 °C

3. Look at the picture below.

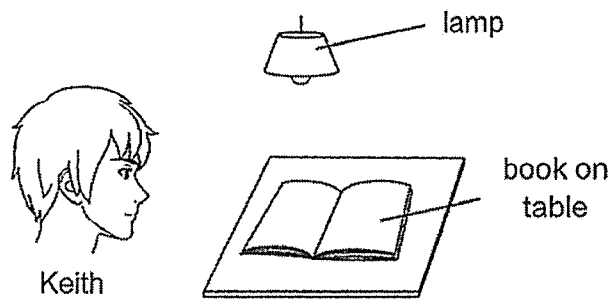

Which one of the following explains why Keith can see the book on the table?

(1)

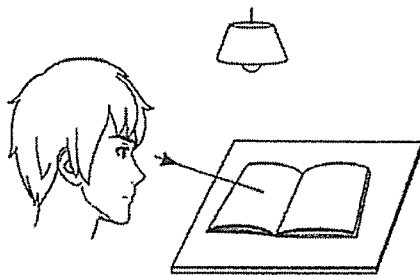

(2)

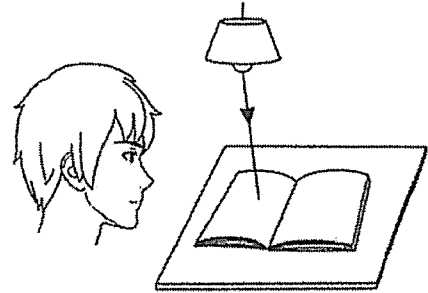

(3)

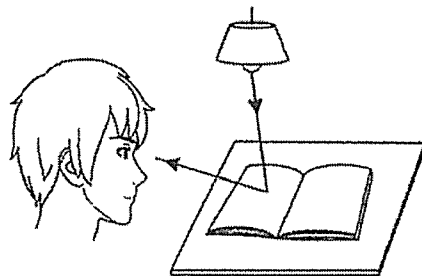

(4)

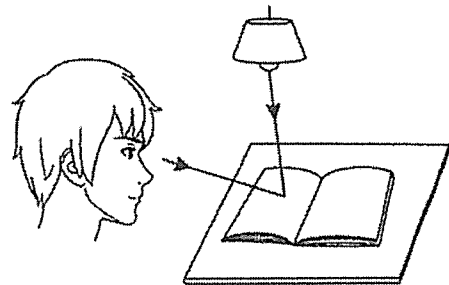

4. Which animal has a pupa as a stage in its life cycle?

- (1) frog
- (2) chicken
- (3) butterfly
- (4) cockroach

5. Matter is anything that has mass and occupies space.

Which one of the following is **not** matter?

- (1) air
- (2) milk
- (3) light
- (4) stone

6. Which part, (1), (2), (3) or (4), makes food for the plant?

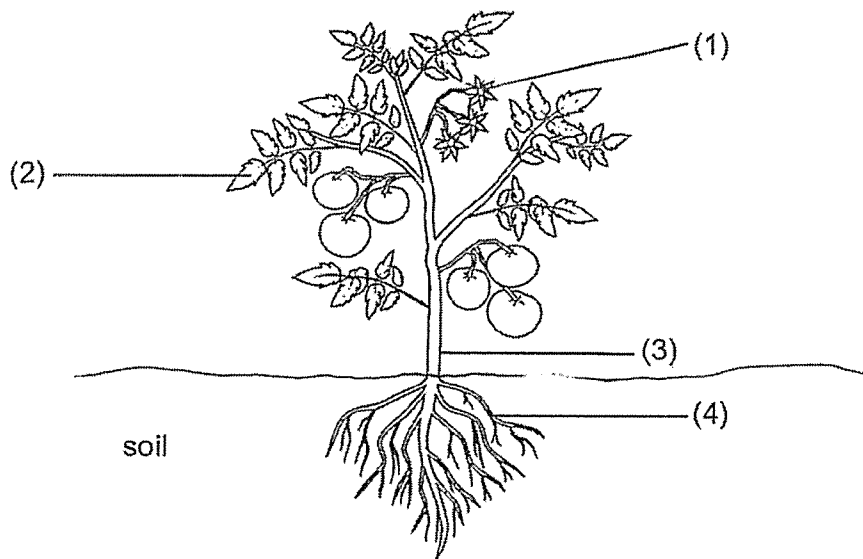

7. Study the diagram below.

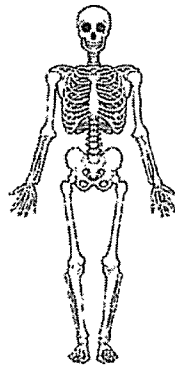

Which human system is shown in the diagram above?

- (1) skeletal system
 - (2) muscular system
 - (3) circulatory system
 - (4) respiratory system
8. The diagram shows a magnet brought near a plastic block.

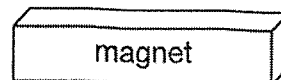
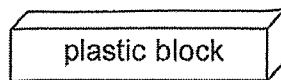

What will happen to the plastic block?

- (1) It will move up.
 - (2) It will not move.
 - (3) It will move to the left.
 - (4) It will move to the right.
9. Which statement is true about most amphibians?
- (1) They have tails.
 - (2) They give birth to their young.
 - (3) They are covered with scales.
 - (4) They can live on land and in water.

10. The diagram shows a hammer.

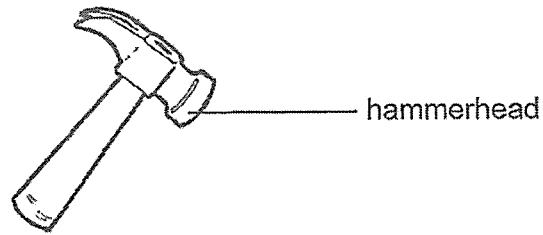

Metal is used to make the hammerhead of the hammer because metal _____.

- (1) can reflect light
 - (2) does not break easily
 - (3) does not absorb water
 - (4) can bend without breaking
11. What will happen to the metal rod when it is heated as shown in the diagram below?

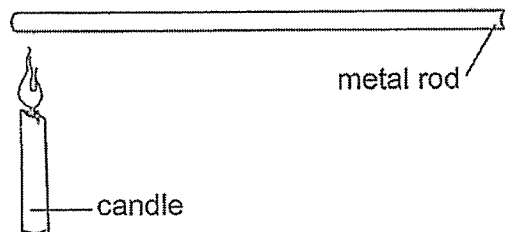

- A. It will become longer.
 - B. It will become shorter.
 - C. It will become heavier.
- (1) A only
 - (2) A and B only
 - (3) B and C only
 - (4) A, B and C only

12. Three identical flasks were filled with coloured water and fitted with a narrow glass tube. The flasks were then placed in basins that had been filled with water of different temperatures at the same time. The liquid levels in the glass tubes after 5 minutes were shown below.

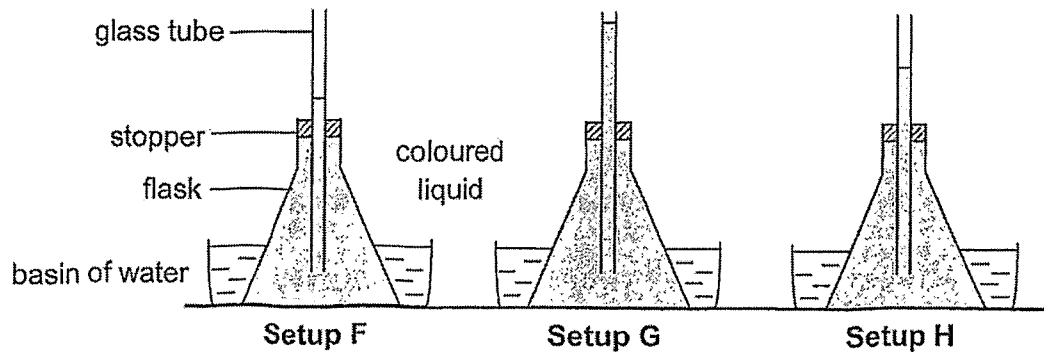

Based on the water level in the glass tube, which of the following shows the correct arrangement of the temperature of water in the basins of the 3 set-ups?

	Highest temperature	→	Lowest temperature
(1)	F		H G
(2)	F		G H
(3)	G		H F
(4)	G		F H

13. The diagram below shows a bowl of hot noodles prepared by Mrs Lee.

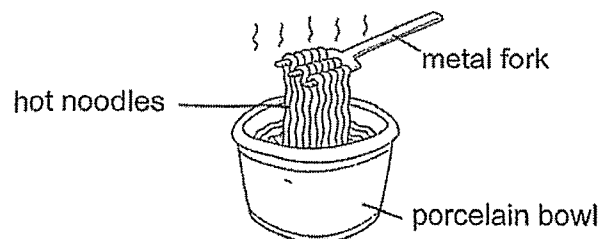

Which of the following correctly shows the process of heat gain and heat lost taking place immediately after she had poured the hot noodles into the bowl?

	metal fork	hot noodles	porcelain bowl
(1)	heat gain	heat gain	heat loss
(2)	heat loss	heat gain	heat gain
(3)	heat gain	heat loss	heat gain
(4)	heat loss	heat loss	heat gain

14. Dirt in water prevents light from passing through. Four water samples, C, D, E and F, were tested to check how dirty the water is. The amount of light that passed through each sample of water was measured using a light sensor.

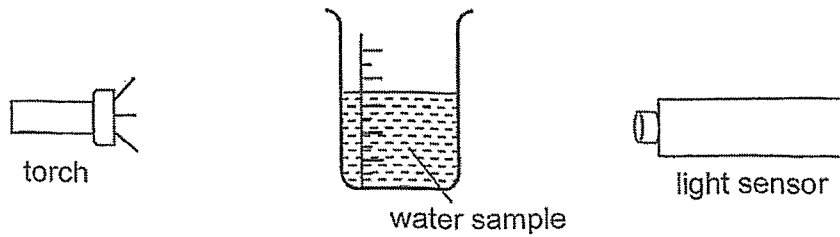

A graph based on the amount of light recorded by the light sensor is shown below.

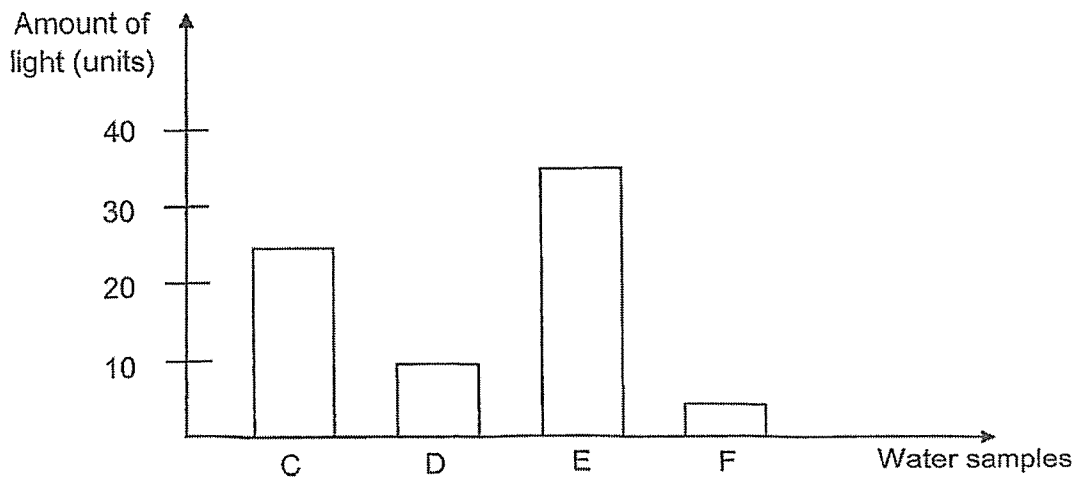

From the graph, which water sample would most likely be the dirtiest?

- (1) C
- (2) D
- (3) E
- (4) F

15. An object casts 2 different shadows, X and Y, when light was shone on it from 2 different angles.

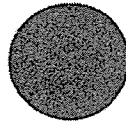

shadow X

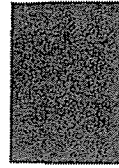

shadow Y

Which of the following objects could have cast shadows X and Y shown above?

(1)

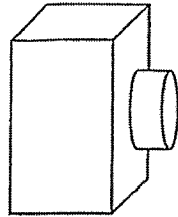

(2)

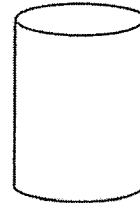

(3)

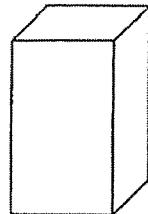

(4)

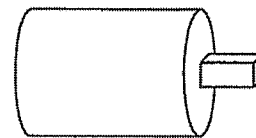

16. Which of the following about the life cycle of a grasshopper is not correct?

- (1) It has a nymph stage.
- (2) It has four stages in its life cycle.
- (3) Its young looks the same as the adult.
- (4) Its young moults several times as it grows.

17. The diagrams below show the different stages in the life cycle of a plant.

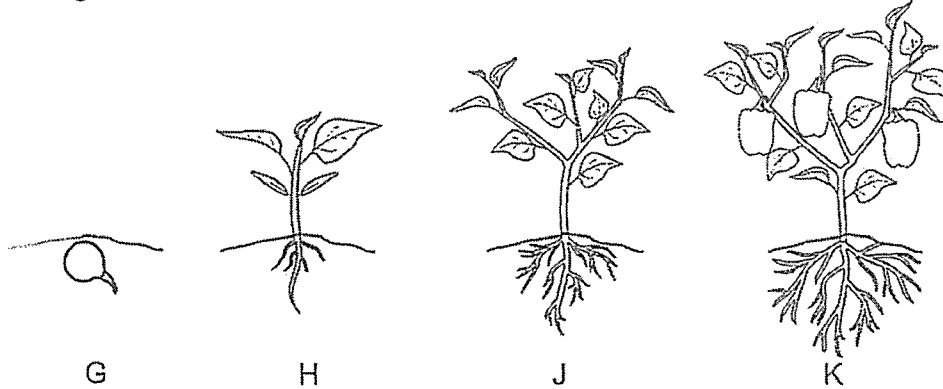

Which of the following statements are correct?

- A. The plant is at its adult stage at H.
- B. The plant can make its own food at J.
- C. The plant shown above is a flowering plant.
- D. The plant above has a four-stage life cycle.

- (1) A and D only
- (2) B and C only
- (3) B, C and D only
- (4) A, B, C and D

18. Study the diagram below.

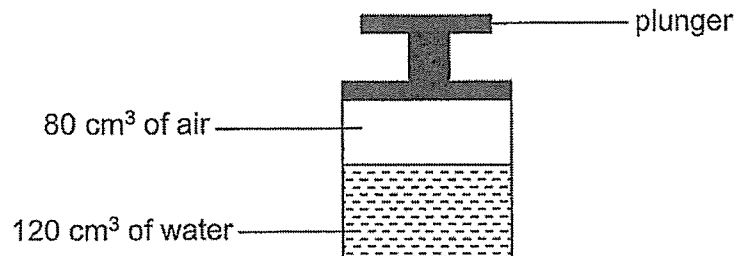

What will happen to the mass and volume of air inside the container when the plunger is pushed down?

	Mass	Volume
(1)	remains the same	increases
(2)	increases	increases
(3)	decreases	decreases
(4)	remains the same	decreases

19. Some boxes, W, X, Y and Z were placed on a beam balance to compare their mass as shown in the diagrams below.

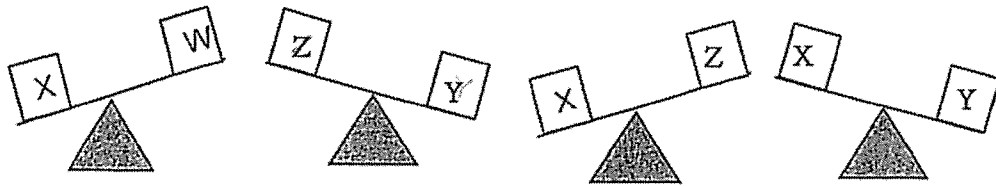

Based on the observations, which box has the greatest mass?

- (1) W
 - (2) X
 - (3) Y
 - (4) Z
20. Study the diagram below. Container Q has 250 cm^3 of water in it.

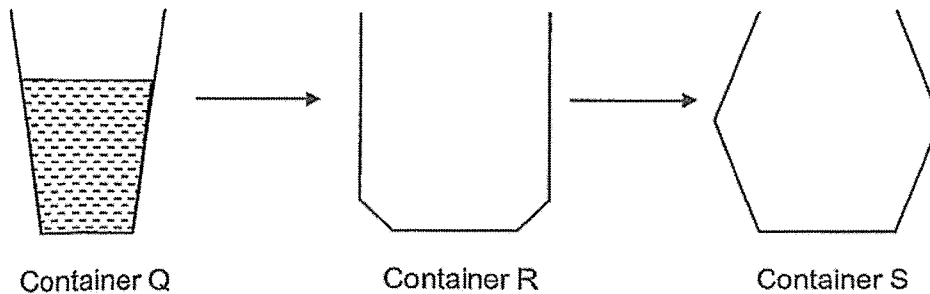

Which of the following will remain the same when all the water is poured from container Q to container R and then to container S, without any water spilling?

- A. mass of water
 - B. shape of water
 - C. volume of water
- (1) A and B only
 - (2) B and C only
 - (3) A and C only
 - (4) A, B and C

21. Josh and Tim were asked to describe the function of a part of a plant. The following are their statements.

Josh: It helps the plant to transport water.

Tim: It helps the plant to obtain sufficient light.

Which part is Josh and Tim referring to?

- (1) flower
 - (2) leaf
 - (3) stem
 - (4) root
22. Marvel wanted to find out if the location of the pots of plants, W, X and Y, affects the growth of plants.

	Pot W	Pot X	Pot Y
size of pot	12 cm	15 cm	18 cm
location of pot	garden	kitchen	cupboard
duration of experiment	one week	one week	one week
number of plants in each pot	3	3	3

Marvel's teacher said that he did not conduct a fair experiment.

What change must he make to make it a fair experiment?

- (1) Use pots of the same size.
- (2) Conduct the experiment for 15 days.
- (3) Place all the pots in the same location.
- (4) Use a different number of plants for each pot.

23. Peter saw some soil being washed down an empty slope with no grass on his way to school during a heavy rain.

soil being washed down the slope



One month later, there were grass growing on the slope. He observed that no soil was washed down the same slope though it rained heavily this time round.

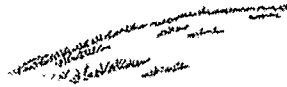

slope with grass growing on it

Which part of the grass helps to prevent the soil from being washed down?

- (1) leaves
 - (2) roots
 - (3) stems
 - (4) seeds
24. A, B and C represent organs in a human digestive system. The graph below shows the amount of undigested food measured leaving each organ.

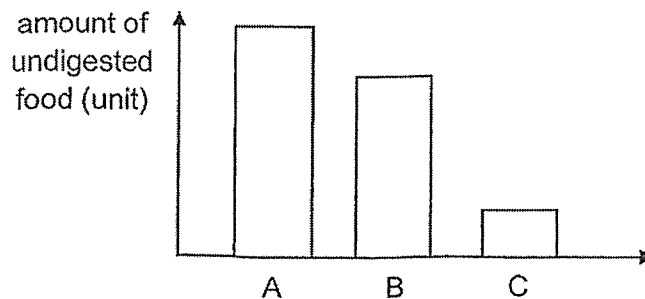

Which of the following correctly identifies organs A, B and C?

	A	B	C
(1)	small intestine	stomach	mouth
(2)	stomach	mouth	small intestine
(3)	mouth	small intestine	stomach
(4)	mouth	stomach	small intestine

25. Five bar magnets with their ends marked from Q to Z can be arranged as shown below, without repelling each other.

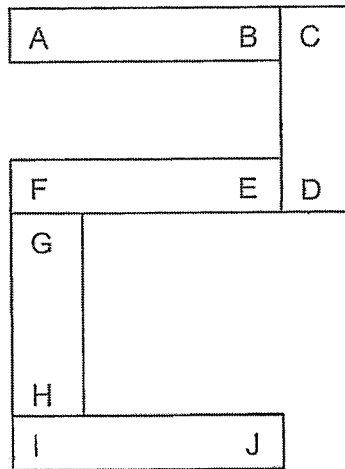

(1)

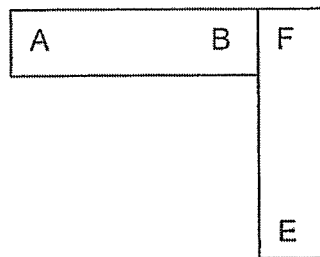

(2)

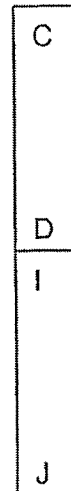

(3)

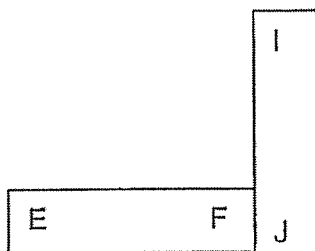

(4)

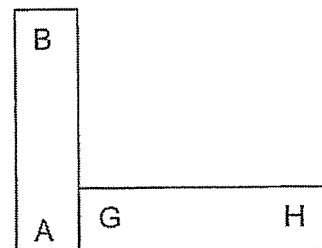

26. Sophie wants to find out whether the number of batteries affects the strength of an electromagnet.

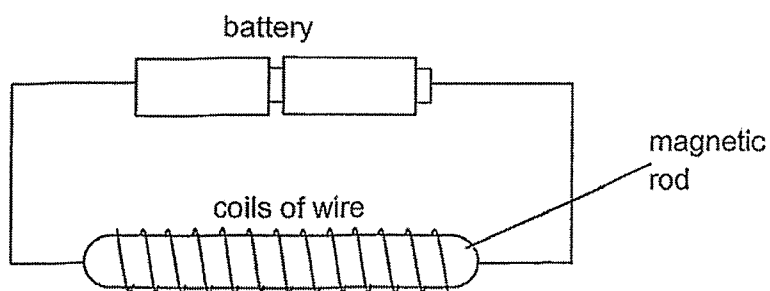

The table below shows the various set-ups.

Set-up	Number of batteries	Number of coils	Material of rod
W	1	30	steel
X	2	20	iron
Y	2	30	steel
Z	1	30	iron

Which two set-ups should she use to conduct her experiment?

- (1) W and Y
- (2) W and Z
- (3) X and Y
- (4) X and Z

27. Study the classification table of living things below.

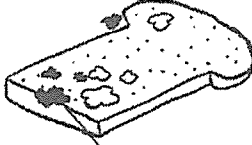
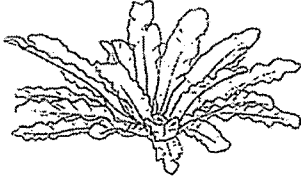
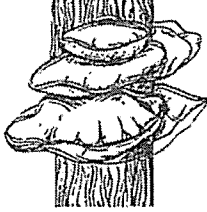
Group J	Group K
 hibiscus plant	 bread mould
 bird's nest fern	 bracket fungus

Which of the following correctly describes groups J and K?

	Group J	Group K
(1)	Flowering plants	Non-flowering plants
(2)	Reproduce from seeds	Reproduce from spores
(3)	Respond to changes	Cannot respond to changes
(4)	Able to make their own food	Unable to make their own food

28. Study the flowchart below.

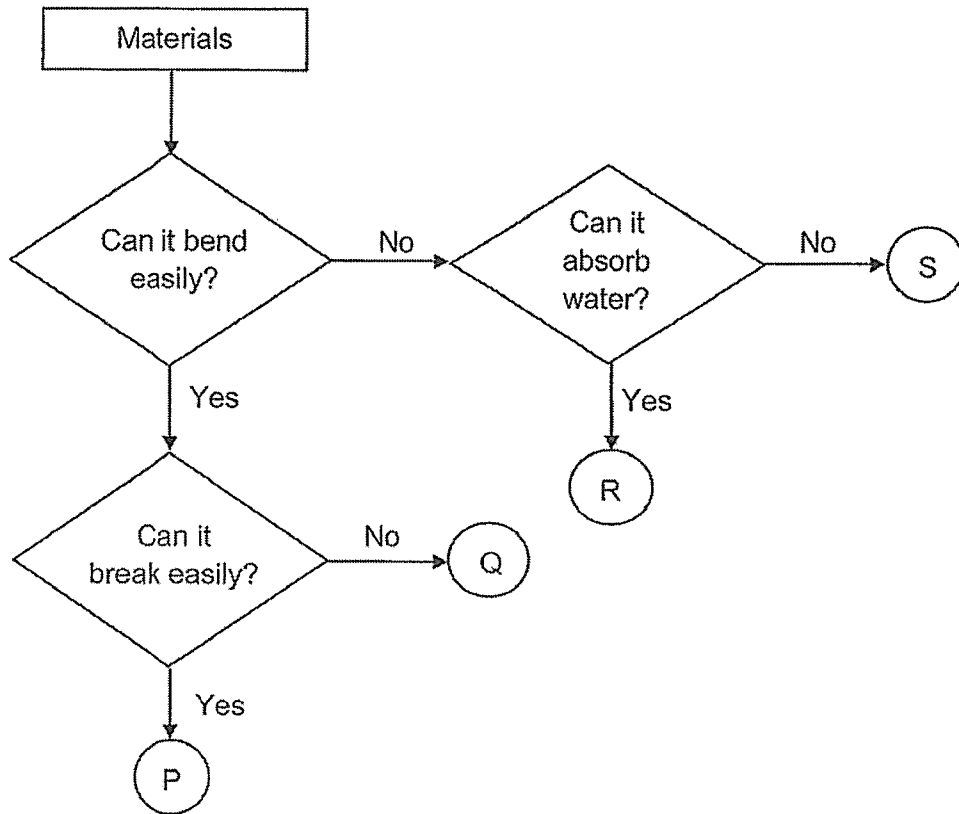

The diagram below shows a water hose.

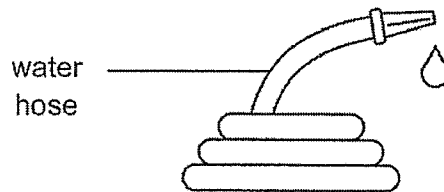

Based on the flowchart, which material, P, Q, R or S is most suitable to make the water hose?

- (1) P
- (2) Q
- (3) R
- (4) S

END OF BOOKLET A

GO ON TO BOOKLET B



MAHA BODHI SCHOOL
2024 END OF YEAR EXAMINATION
PRIMARY FOUR SCIENCE
(BOOKLET B)

Name: _____ ()

Class: Primary 4 _____

Date : 24 Oct 2024

Total Duration for Booklets A and B: 1 h 45 min

INSTRUCTIONS TO CANDIDATES:

1. Do not turn over this page until you are told to do so.
2. Follow all instructions carefully.
3. Answer all questions.
4. Write all your answer in this booklet.

Booklet	Marks Obtained	Max Marks
A		56
B		44
Total		100

Parent's signature: _____

This booklet consists of 15 printed pages.

BLANK PAGE

BOOKLET B : [44 marks]

For questions 29 to 40, write your answers in this booklet.

The number of marks available is shown in the brackets [] at the end of each question or part-question.

29. The diagram below shows a cooking pot.

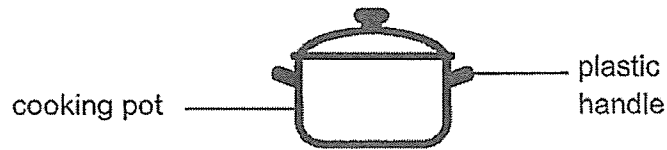

(a) The handle is made of plastic because it is a _____ conductor of heat. [1]

(b) The pot is made of metal because it is a _____ conductor of heat. [1]

30. Classify the animals according to the number of stages in their life cycle. [3]



butterfly



frog



grasshopper



mosquito

Three stages	Four stages

Marks :

/ 5

31. Fill in the correct parts of a plant in the table.



[2]

Function of plant part	Plant part
It holds the plant upright.	
It holds the plant firmly to the ground.	

32. Identify the outer covering of each animal group by choosing the words from the box.

[3]

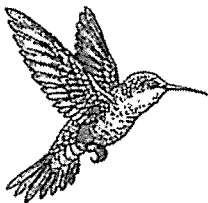
hair	feather	scales	moist skin
------	---------	--------	------------

	Animal Group	Outer covering
(a)	 bird	
(b)	 mammal	
(c)	 reptile	

Marks :

/ 5

33. The diagrams below show the life cycle of animals X and Y.

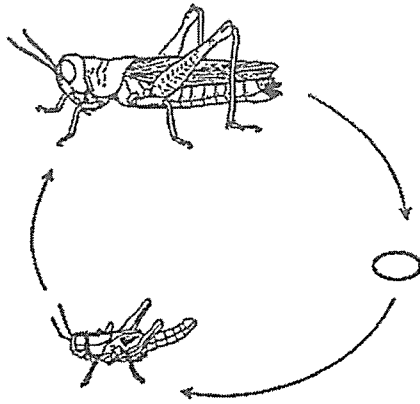

Life cycle of animal X

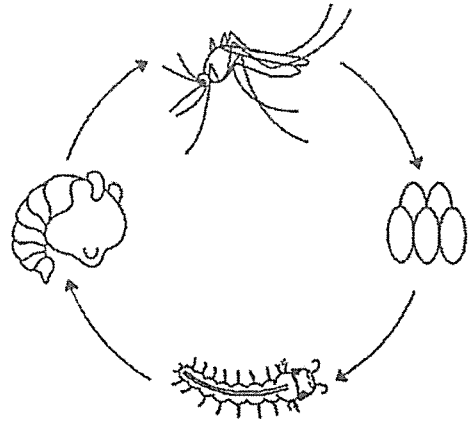

Life cycle of animal Y

(a) State a similarity between the life cycle of animal X and animal Y. [1]

(b) State a difference between the life cycle of animal X and animal Y. [1]

(c) Each time, both the adults of animals X and Y lay many eggs. Explain how this helps both animals to survive. [1]

(d) Animal Y is a pest that spreads diseases. At which stage of animal Y will it be difficult to kill? State the reason why. [1]

Marks :

--

 / 4

34. (a) The diagram shows a plant.

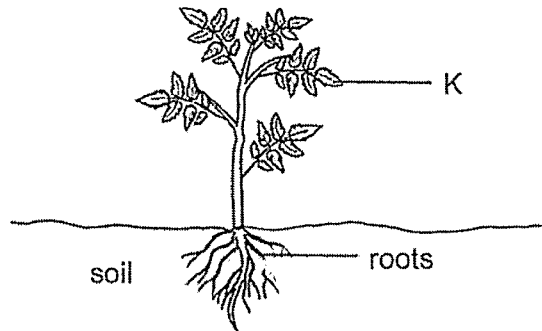

(i) Label plant part K. [1]

(ii) State one substance that the roots take in from the soil. [1]

(b) Four similar plants were placed in identical containers with the same amount of water as shown below.

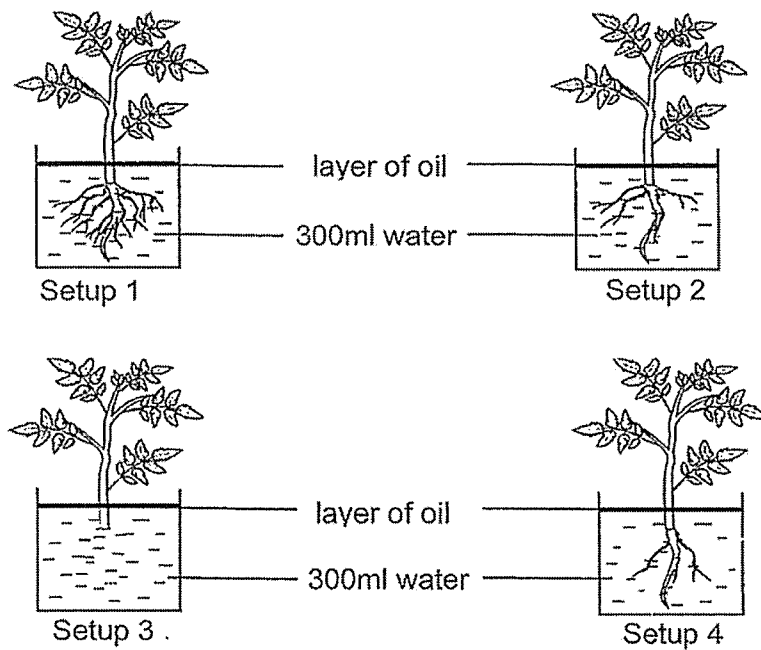

Marks :

2 / 2

34. (b) Five days later, the amount of water in each container was measured and recorded in the table below.

Set-up	Amount of water (ml)
1	150
2	200
3	300
4	250

- (i) Based on the results above, state the relationship between the amount of water left in the container and the number of roots on the plant. [1]

- (ii) Explain why this relationship is observed in (b)(i). [1]

Marks :

/ 2

35. The flowchart below shows the properties of X, Y and Z.

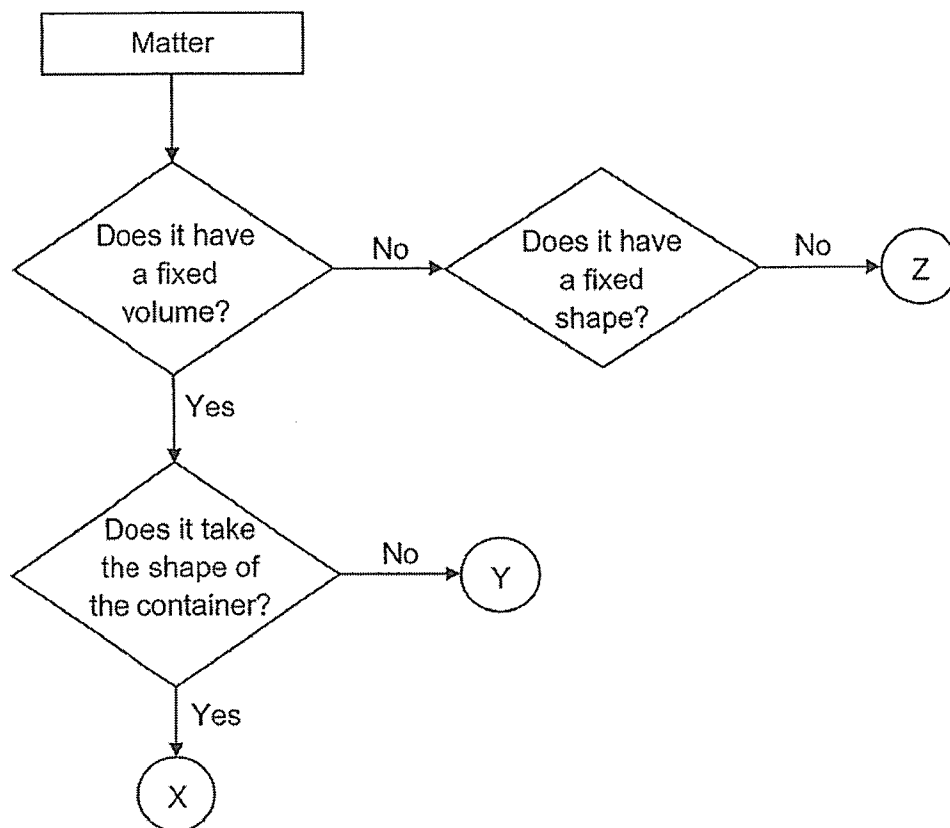

(a) Based on the flowchart above, state all the properties of matter Z. [2]

(b) Based on the flowchart above, what is the state of matter of Y? [1]

(c) Gene claimed that an example of matter X is a metal spoon as it has a fixed volume. Explain why Gene is wrong. [1]

Marks :

/ 4

36. Kelly has a container which was separated by a stopper. The left side was filled with substance K. When she pulled the stopper up, she observed that substance K occupied some space on the right side of the container as shown below.

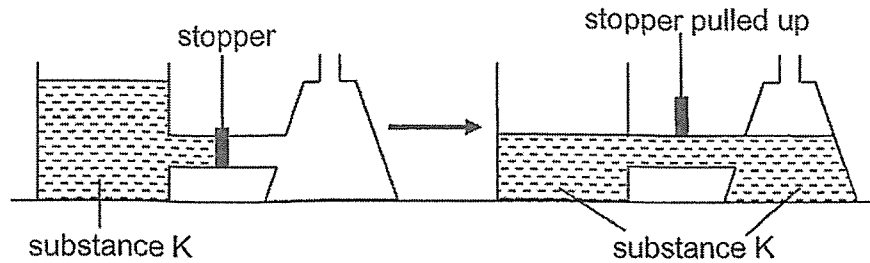

- (a) Based on her observation, what property of matter was shown by substance K? [1]

- (b) Based on the diagram, identify the state of matter of substance K. [1]

Kelly then filled two containers, A and B, as shown in the diagram below.

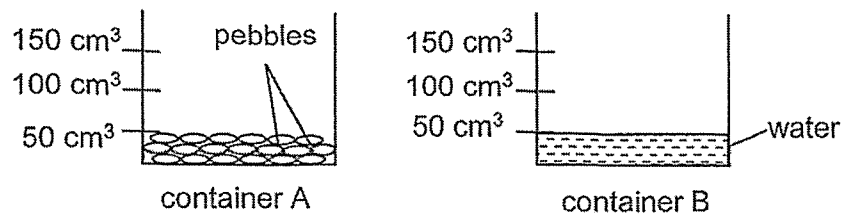

- (c) (i) The water from container B was then poured into container A.

Put a tick (✓) in one of the boxes below to indicate the correct water level in container A after the water was transferred. [1]

	50 cm ³	75 cm ³	100 cm ³	125 cm ³
Water level in container A				

- (ii) Explain your answer in c(i). [2]

Marks :

/ 5

37. The following shapes were cut out from a piece of cardboard as shown below. The two shapes are of the same height and width.

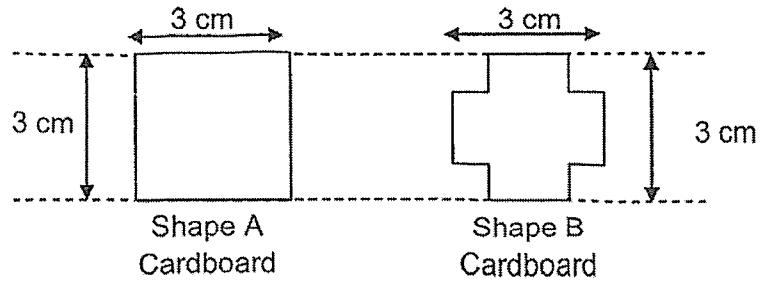

- (a) Shape A was placed in position 1 and shape B is placed in position 2 respectively in front of the torch.

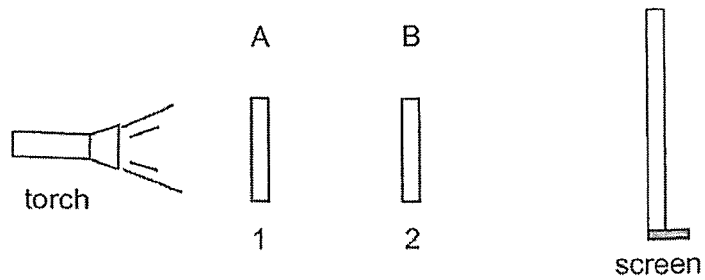

Put a tick (✓) in the box that shows the shadow that will be seen on the screen above. [1]

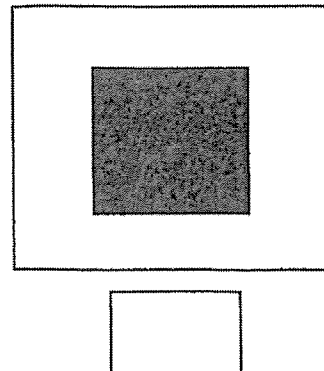
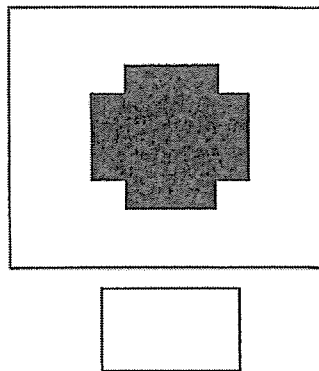

- (b) What can you conclude about the property of light from the experiment? [1]

Marks :

37. (c) Dan walked in a straight line from P to R as shown in below. The distance between P and Q is the same as the distance between Q and R.

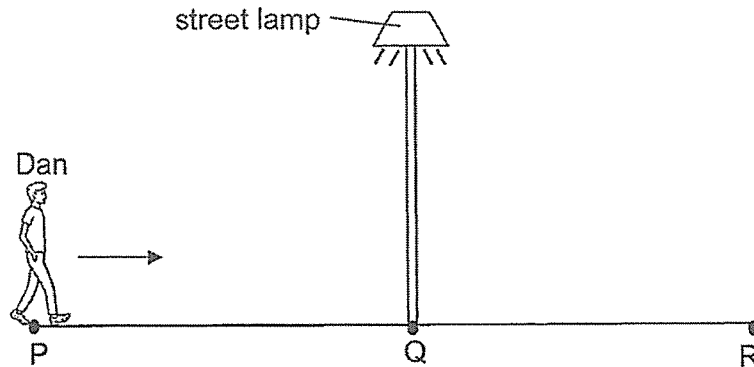

The graph below shows how the length of Dan's shadow on the ground changed during his walk.

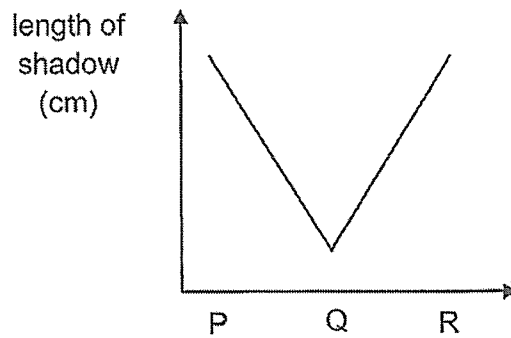

- (i) How did the length of Dan's shadow change as he walked from P to Q and then from Q to R? [1]

P to Q : _____ Q to R : _____

- (ii) Explain how the distance from the lamp affected the length of the shadow. [1]

Marks :

/ 2

38. Annie set up an experiment as shown below. Both the metal containers G and H and the amount of water were kept the same.

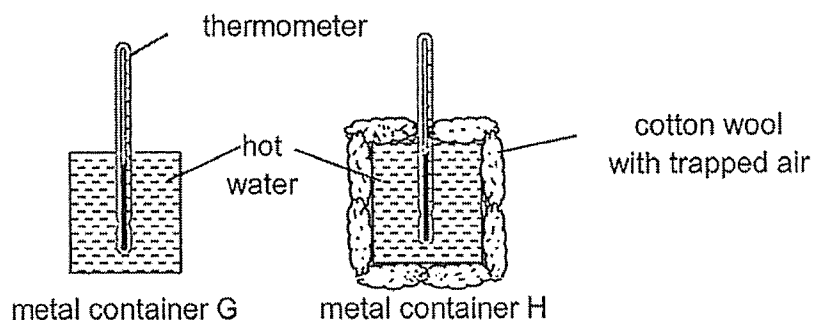

Annie recorded the temperature of the water in containers G and H in the table below.

Time (mins)	Container G ($^{\circ}\text{C}$)	Container H ($^{\circ}\text{C}$)
0	80	80
10	66	69
20	52	60
30	45	58

- (a) State the reason why the temperature of water in both containers G and H decreased. [1]
-
- (b) State the difference in temperature change of water in containers G and H. [1]
-
- (c) How does the air in the cotton wool affect the decrease in temperature of the water in container H? [2]
-
-
-

Marks : / 4

- 38 (d) Using the same set-up as above, which container would you place ice cubes in so that the ice cubes take a longer time to melt?
Explain your answer. [1]

Marks :

/ 1

39. Caleb made a magnet by using the method shown below.

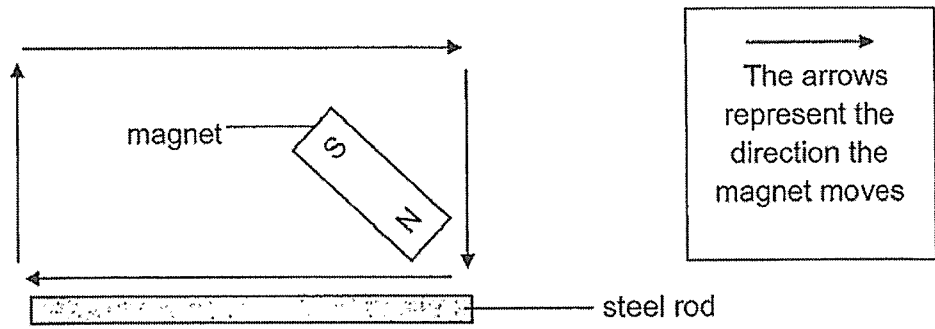

(a) State the name of the method above. [1]

(b) He then placed the magnetised steel rod near a bar magnet and observed what happened next. Identify the pole labelled part X of the steel rod.

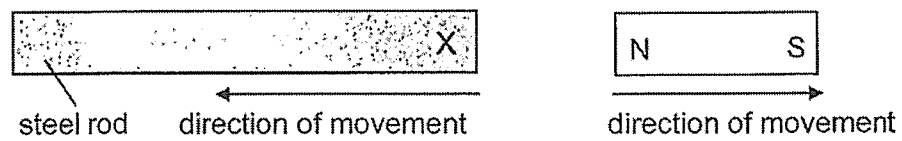

X is the _____ [1]

(c) Caleb hung three unknown objects D, E and F, next to each other on a plastic rod. Two of the unknown objects are magnets. The diagram below shows their positions at rest.

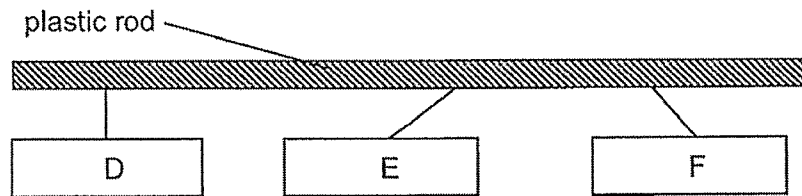

(i) Which two unknown objects, D, E or F are magnets. Explain your answer. [1]

Marks : / 3

- (c) (ii) Caleb decided to use a magnet on object D, using the method shown below.

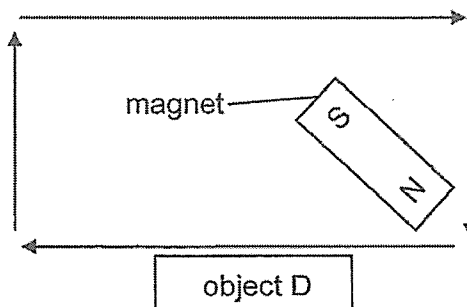

He observed that object D did not become a magnet. State the reason why he could not magnetise D. [1]

Marks :

/ 1

40. Jenny carried out an experiment to test out the property of the rod made of material X. She secured one end of the rod on the tabletop using a clamp. She taped a 150g weight at the end of the rod. She observed that the rod moved downwards and recorded the distance it bent.

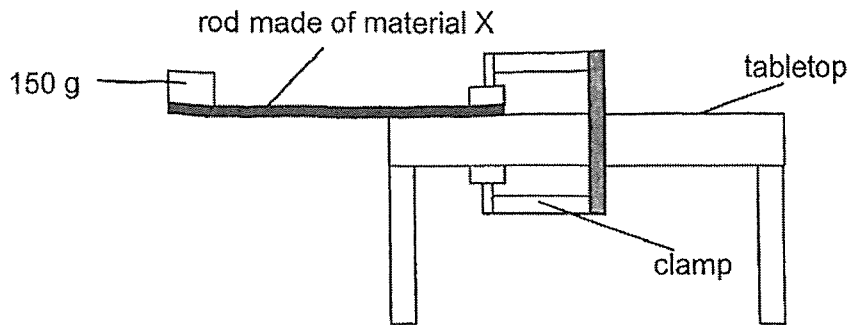

She repeated the experiment with 2 other rods made of materials Y and Z. She recorded the results in the table below.

Material	Distance the rod bent (cm)
X	6
Y	1
Z	9

- (a) What is the property of the rods that Jenny was testing? [1]

- (b) Identify the variable in the experiment that was measured. [1]

Marks : / 2

40. (c) Look at the scissor below.



Which material, X, Y or Z, is the most suitable to make the blades of the scissors? Explain why. [2]

Marks : / 2

END OF PAPER

MAHA BODHI SCHOOL
2024 END OF YEAR EXAMINATION
PRIMARY FOUR SCIENCE

BOOKLET A: 56 marks

1. 4	6. 2	11. 1	16. 2	21. 3	26. 1
2. 2	7. 1	12. 3	17. 2	22. 1	27. 4
3. 3	8. 2	13. 3	18. 4	23. 2	28. 2
4. 3	9. 4	14. 4	19. 3	24. 4	
5. 3	10. 2	15. 2	20. 3	25. 2	

BOOKLET B: 44 marks

Qn		Answers
29	a	bad/poor/poorer
	b	good/better
30	a	Three stages – frog and grasshopper Four stages – butterfly and mosquito
31	a	Stem Root/Roots
32	a	feather
	b	hair (fur)
	c	scales
33	a	ANY ONE Both have an egg stage. / Both hatch from eggs. Both reproduce by laying eggs. / Both lay eggs. Both have an adult stage. / Both adults have wings.
	b	ANY ONE Animal X has a 3-stage life cycle while animal Y has a 4-stage life cycle. OR Animal X's young looks like the adult while animal Y's young does not look like the adult.

Qn		Answers
		<p>OR Animal X has a nymph stage while Animal Y does not have a nymph stage.</p> <p>OR Animal Y has a pupa/larva stage while Animal X has no pupa/larva stage.</p>
	c	<p>ANY ONE If some of the eggs are eaten, there will still be some eggs that can hatch.</p> <p>OR If some of the eggs do not hatch, there will still be some eggs that can hatch.</p> <p>OR It will increase their chances of survival.</p> <p>OR More eggs can grow into adult. / More eggs can hatch.</p>
	d	At the adult stage ($\frac{1}{2}$) because it has wings and can fly away($\frac{1}{2}$).
34	a	i leaf/leaves
		ii Water /Mineral (salts)
	b	i ANY ONE As the number of roots decreases , the amount of water left in the container increases . <p>OR As the number of roots increases, the amount of water left in the container decreases.</p>
		ii Roots absorb water. When there are more roots , more water will be absorbed, so there is less water in the container.
35	a	ANY ONE Z has no fixed volume and no fixed shape. <p>OR Z is compressible and takes the shape of the container.</p>
	b	Y is a solid.
	c	ANY ONE X takes the shape of the container while a metal spoon does not. <p>OR A metal spoon has a fixed shape while X does not.</p>

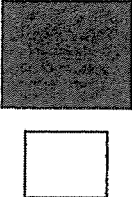
Qn		Answers													
			OR X is a liquid while a metal spoon is a solid. <i>*Must show comparison*</i>												
36	a		Matter occupied space.												
	b		Liquid												
			<table border="1"> <thead> <tr> <th></th> <th>50 cm³</th> <th>75 cm³</th> <th>100 cm³</th> <th>125 cm³</th> </tr> </thead> <tbody> <tr> <td>Water level in container A</td> <td></td> <td></td> <td></td> <td></td> </tr> </tbody> </table>				50 cm ³	75 cm ³	100 cm ³	125 cm ³	Water level in container A				
	50 cm ³	75 cm ³	100 cm ³	125 cm ³											
Water level in container A															
	c	ii	As there are gaps/spaces between the pebbles(1m), the water will occupy the space between the gaps so the water level will be 75cm ³ (1m).												
37	a														
	b		Light travels in a straight line (½) and shadows are formed when light is blocked (½).												
	c	(i)	P to Q: Decreased / became shorter Q to R: Increased / became longer												
		(ii)	ANY ONE The nearer the person is to the lamp, the length of shadow decreases (becomes smaller). OR The further the person is from the lamp, the length of shadow increases (becomes bigger).												
38	a		The hot water lost heat to the surroundings.												
	b		ANY ONE Temperature of water in G decreased faster/more than H. OR Temperature of water in H decreased slower/lesser than G												

Qn		Answers
	c	Air in the cotton wool is a poor conductor of heat . Thus, it slows down heat loss from the water to the surroundings. This results in a slower decrease in temperature.
	d	Container H. Ice cubes will take a longer time to gain heat from the surroundings.
39	a	Stroke method
	b	X is North pole / North
	c (i)	E and F are magnets. They repel as only magnets can repel each other.
	c (ii)	Object D is a <u>non-magnetic material</u> so it <u>cannot be magnetised</u> .
40	a	Flexibility
	b	ANY ONE The distance the rod bent OR How much the rod/ material bent
	c	Material Y as it bends the least(1m) so it is the least flexible / most rigid / most stiff material. (1m)

more papers at www.sgtermpaper.com