



NAN HUA PRIMARY SCHOOL
TERM 2 NON-WEIGHTED ASSESSMENT 2023
PRIMARY 6
SCIENCE
BOOKLET A

28 Multiple Choice Questions (56 marks)

Total Time for Booklets A and B: 1 hour 45 minutes

INSTRUCTIONS TO CANDIDATES

1. Write your name, index number and class in the spaces provided below.
2. Do not turn over the page until you are told to do so.
3. Follow all instructions carefully.
4. Answer all questions.
5. Use a 2B pencil to shade your answers on the Optical Answer Sheet (OAS).

Marks Obtained

Booklet A		/ 56
Booklet B		/ 44
Total		/ 100

Name: _____ ()

Form Class P6 _____

Teaching Group 6S _____

Date: 16th May 2023

Parent's Signature: _____

This booklet consists of 20 printed pages.

Section A: (28 x 2 marks = 56 marks)

For each question from 1 to 28, four options are given. One of them is the correct answer. Make your choice (1, 2, 3 or 4) and shade your answer on the Optical Answer Sheet.

1 Study the chart below carefully.

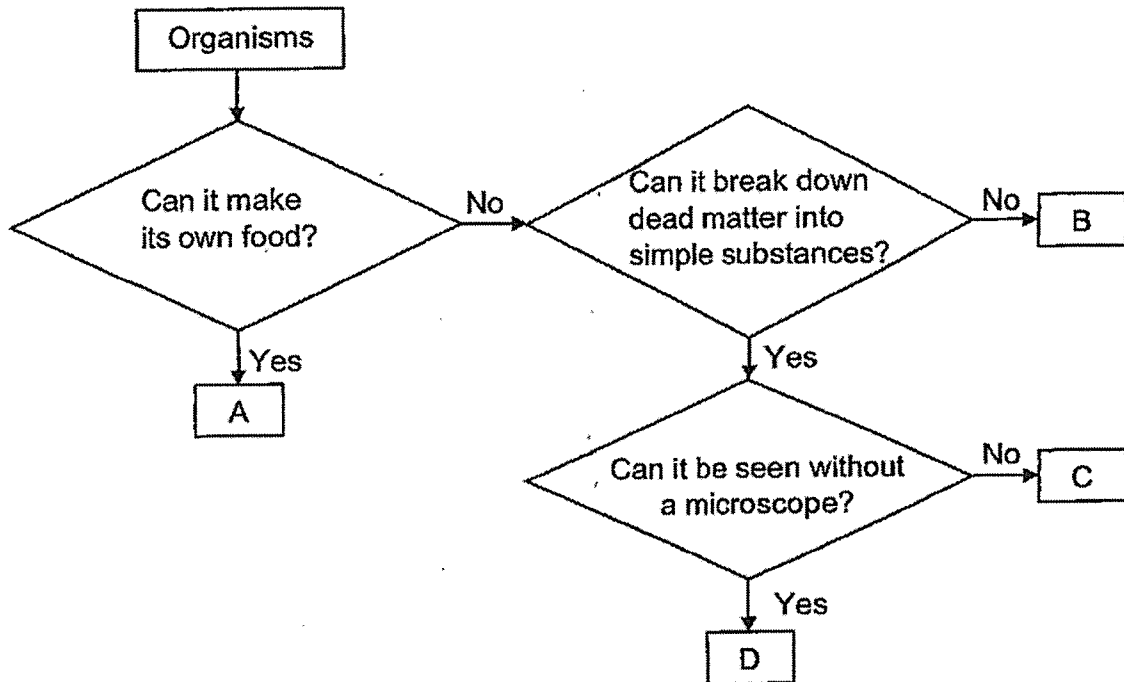

Which organism is a mushroom?

- (1) A
- (2) B
- (3) C
- (4) D

2 Which of the following statements about the human reproduction system is correct?

- (1) One egg can be fertilised by many sperms.
- (2) The ovary produces the male reproductive cells.
- (3) The foetus will develop in the womb of the female.
- (4) Sperms contain the female reproductive cells needed for fertilisation to take place.

- 3 The diagram below shows the life cycle of two animals, Y and Z.

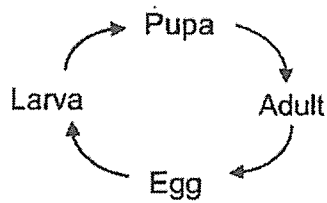

Life cycle of Y

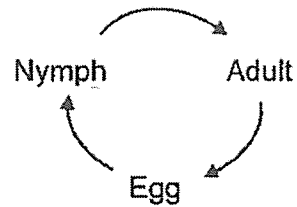

Life cycle of Z

Which of the following animals have a similar life cycle as Y and Z?

	Y	Z
(1)	frog	cockroach
(2)	beetle	chicken
(3)	butterfly	frog
(4)	mosquito	grasshopper

- 4 Which of the following statement(s) about heredity in humans is/are true?
- A A young will have characteristics of both parents.
 - B A female cannot pass down her traits to a male child.
 - C Heredity is the passing down of traits from one young to another.
 - D To produce a young, both the male and female reproductive cells are needed.
- (1) A and C only
 (2) A and D only
 (3) B and C only
 (4) B and D only

(Go on to the next page)

5 The diagrams below show an animal cell and a plant cell.

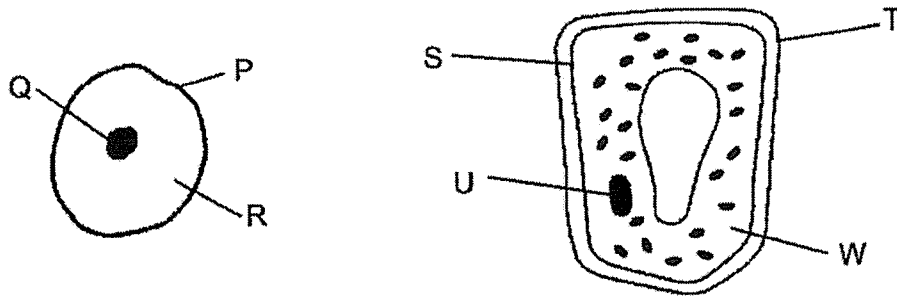

Four students made the following comments.

- Ariel Q and U perform similar functions.
- Ben P and T ensure the cells have a regular shape.
- Cindy P and S only control the substances moving into the cell.
- Dennis R and W control the activities that take place within the cell.

Which of the student(s) has / have made the correct statement(s)?

- (1) Ariel only
- (2) Ben and Cindy only
- (3) Cindy and Dennis only
- (4) Ariel, Ben and Dennis only

- 6 The diagram below shows the locations of both adult and young plants of three types of plants.

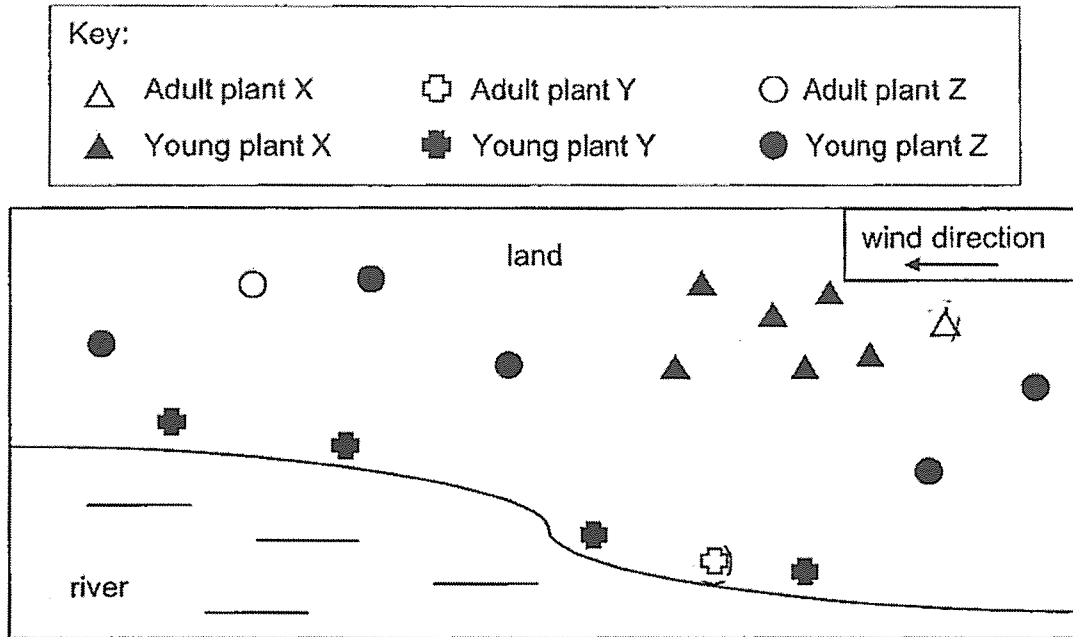

The diagrams below show the characteristics of four fruits, A, B, C and D.

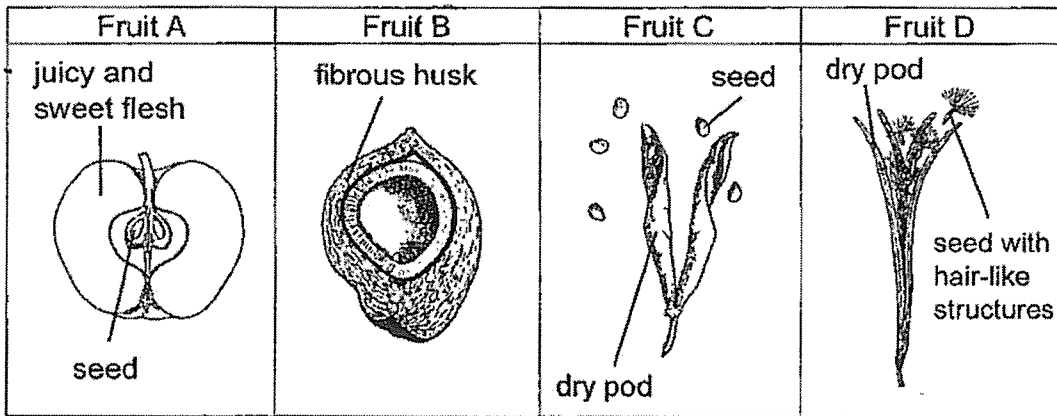

Which of the following fruits most likely belong to plants, X, Y and Z?

	Plant X	Plant Y	Plant Z
(1)	A	C	D
(2)	B	D	C
(3)	C	B	A
(4)	D	B	A

4

5

(Go on to the next page)

7 The diagram below shows the human digestive system.

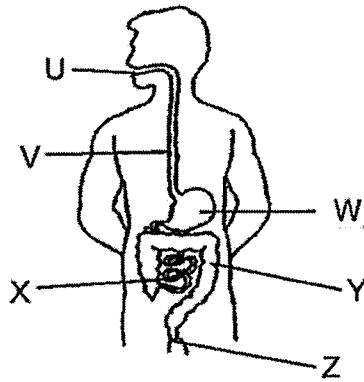

Which of the following correctly describes the function(s) of some organs in the digestive system?

	Organ(s) where	
	digestion takes place	digested food is absorbed into the bloodstream
(1)	W and X	V and Y
(2)	X and Y	Y
(3)	U, W and X	X
(4)	U, W and X	X and Y

8 The diagram shows the human respiratory system.

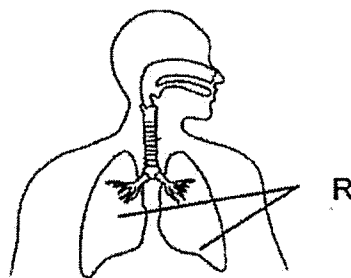

Which of the following statements about R is correct?

- (1) R helps to pump oxygen into the bloodstream.
- (2) R helps to take in air and water from the surroundings.
- (3) R has many blood vessels to increase the rate of absorption of oxygen into the bloodstream.
- (4) R has many blood vessels to increase the rate of absorption of carbon dioxide into the bloodstream.

- 9 Kim removed the water-carrying and food-carrying tubes at some parts of a plant and made observations of the plant at the start and end of the experiment. She noted that the plant was growing healthily at the start of the experiment.

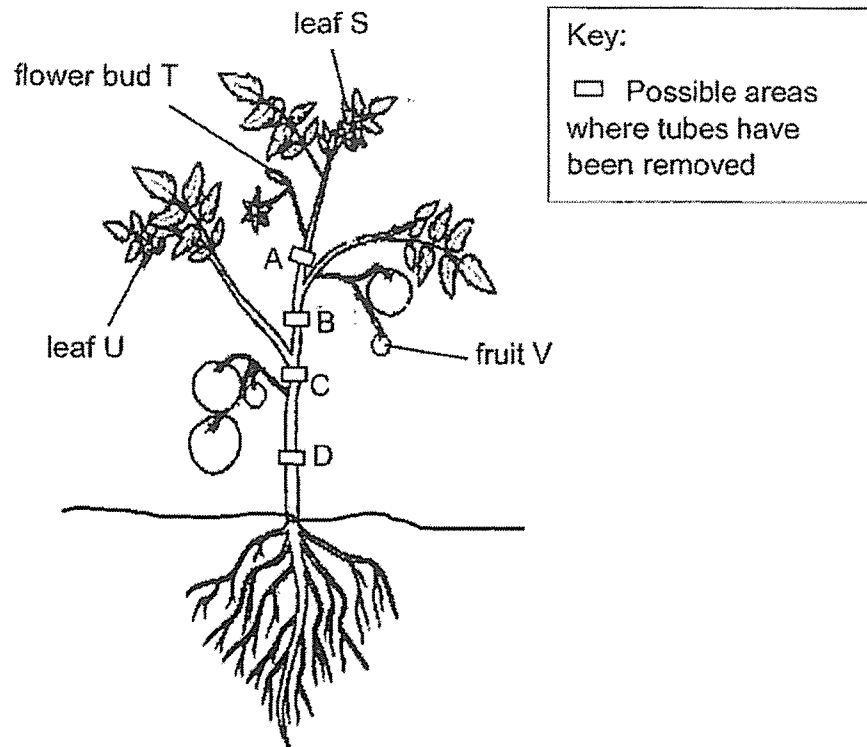

Her observations at the end of the experiment are as follows:

Observations	
1	Leaf S withered and dropped off.
2	Flower bud T withered and dropped off.
3	Leaf U grew bigger in size.
4	Fruit V grew bigger in size.

At which point, A, B, C or D, was both the food-carrying and water-carrying tubes removed?

- (1) A
- (2) B
- (3) C
- (4) D

(Go on to the next page)

10 The diagram below shows how blood flows in the human body.

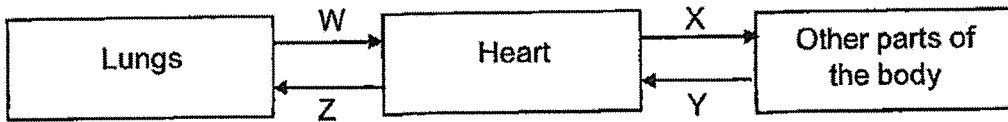

Same amount of blood was taken from blood vessels, W, X, Y and Z. The amount of oxygen in the blood was compared.

Which one of the following graphs is correct?

(1)

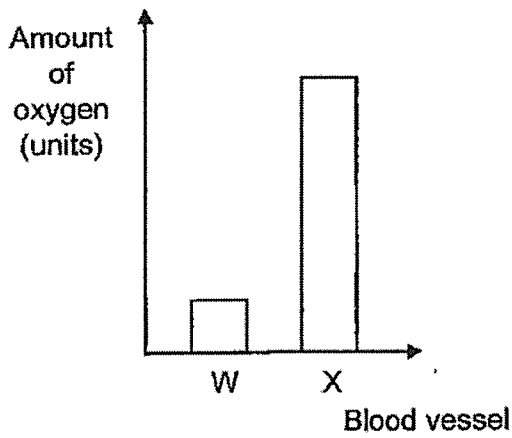

(2)

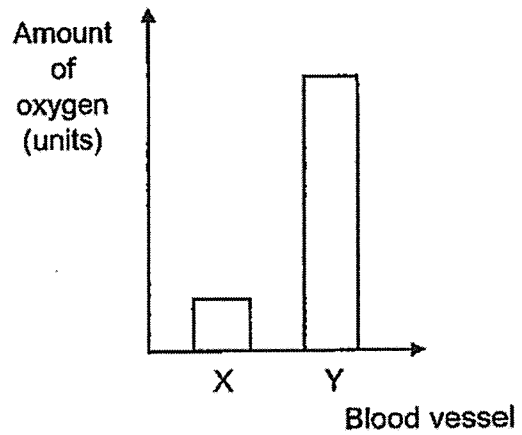

(3)

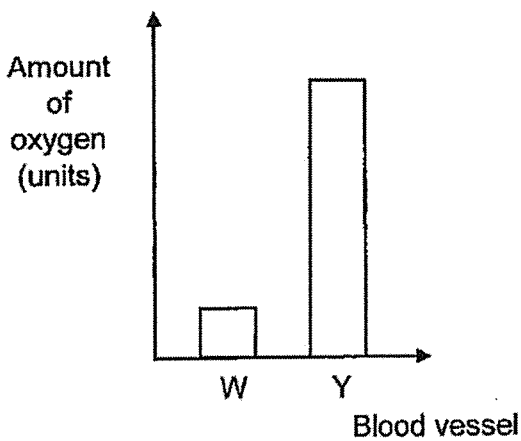

(4)

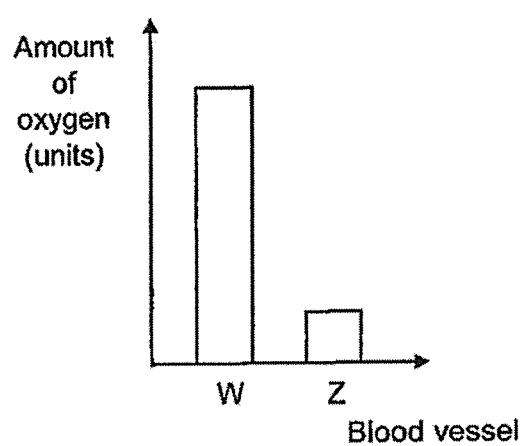

- 11 Janice placed a well-watered plant inside a metal box. She then placed the whole set-up under the Sun for three hours.

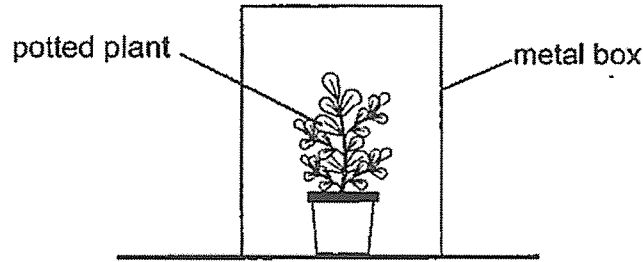

Which of the following correctly shows the changes in the amount of gases inside the metal box after three hours?

	Oxygen	Carbon dioxide	Water vapour
(1)	increases	increases	increases
(2)	increases	decreases	decreases
(3)	decreases	increases	increases
(4)	decreases	decreases	decreases

- 12 What is a population?

- (1) A place where an organism lives, grows and reproduce.
- (2) A group of different species living together in a particular place.
- (3) A living thing that can be a micro-organism, plant, animal or fungus.
- (4) A group of living things of the same kind that live together and reproduce in a particular place.

(Go on to the next page)

- 13 The graph below shows how the temperature of the environment affects the population of three different organisms, D, E and F.

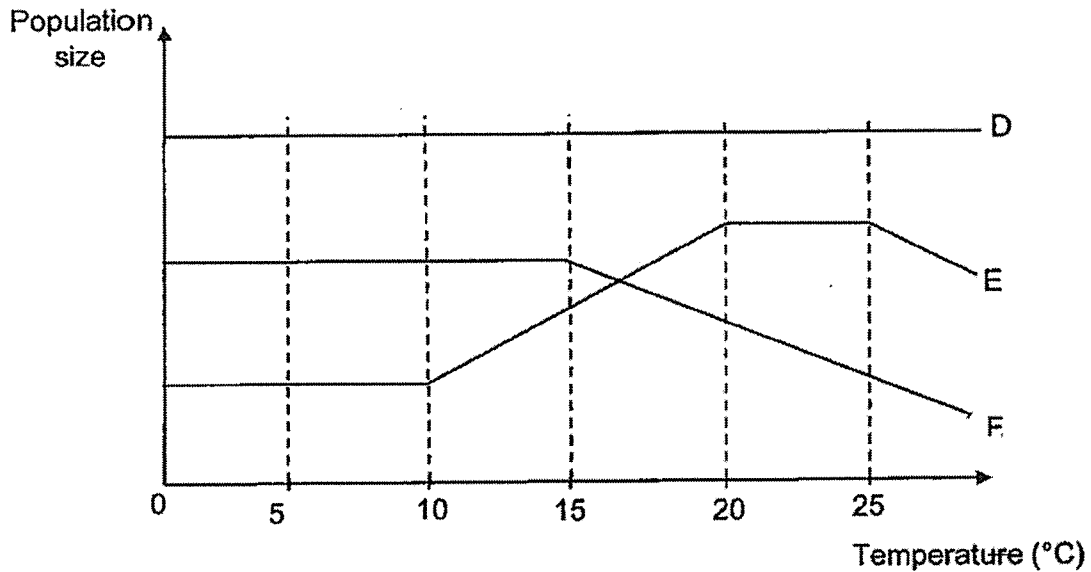

Which of the following statements is/are true?

- W The best temperature for organism F to grow well is below 15°C.
- X Organism E grow well at a temperature between 20°C and 25°C.
- Y There is a greater number of organism D at a temperature above 20°C.
- Z Only 2 out of the 3 organisms are affected by changes in the temperature of the environment from 0°C to 25°C.

- (1) X only
- (2) W and Z only
- (3) X and Y only
- (4) W, X and Z only

14 Organism P is considered a pest in a farm. A farmer successfully reduced the population of organism P in his farm within a short period of time. He did the following:

- Introduce more organism Q
- Introduce more organism R
- Reduce the population of S

Which one of the following correctly shows the food relationships of organisms P, Q, R, S and T?

(1)

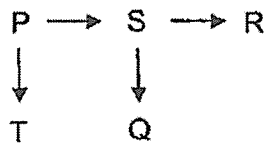

(2)

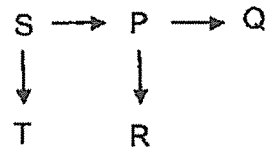

(3)

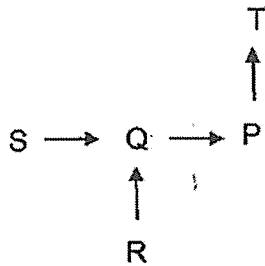

(4)

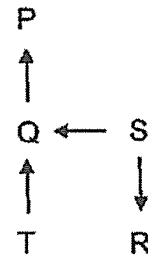

(Go on to the next page)

15 Study the flowchart below.

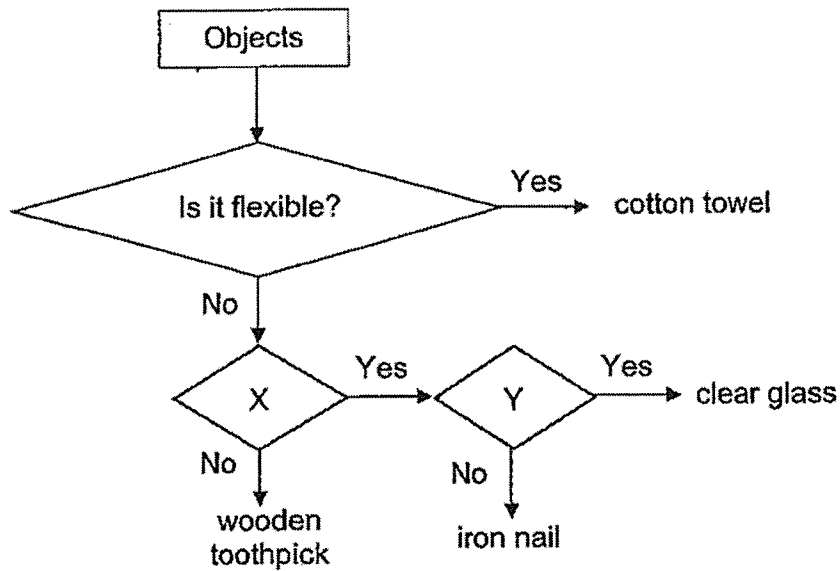

Which of the following headings for X and Y are correct?

	X	Y
(1)	Does it float on water?	Is it strong?
(2)	Is it strong?	Does it float on water?
(3)	Does it allow light to pass through?	Is it waterproof?
(4)	Is it waterproof?	Does it allow light to pass through?

- 16 Pei Shi conducted an experiment with material A using the set-up as shown below. She attached a load to a toy car to pull it across the table and recorded the time taken for the toy car to reach Point M.

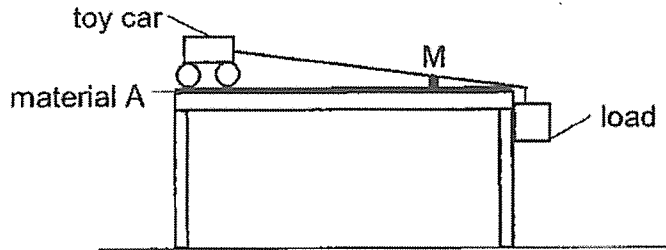

The experiment was then repeated for materials, B, C and D, one at a time. Pei Shi recorded the results as shown below.

Material	Average time taken for the toy car to reach point M (s)
A	3.5
B	2.0
C	3.0
D	2.5

Based on the results above, which material is best suited to make into a bathroom mat to prevent falls due to slippery floor?

- (1) A
- (2) B
- (3) C
- (4) D

- 17 At which of the following temperatures can water exist in the liquid state?

- | | |
|---|--------|
| A | 0 °C |
| B | 50 °C |
| C | 80 °C |
| D | 100 °C |

- (1) B only
- (2) A and B only
- (3) B and C only
- (4) All of the above

(Go on to the next page)

- 18 A deflated balloon was stretched over the mouth of a container. When air was blown into the opening, the balloon could only inflate slightly as shown below.

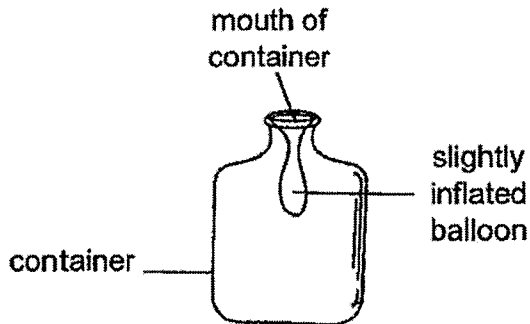

Which of the following statements explains why the balloon could inflate slightly but not fully?

- (1) Air in the balloon has a definite volume and occupies space.
- (2) Air in the container has no definite volume and occupies space.
- (3) Air in the balloon has no definite volume and cannot be compressed.
- (4) Air in the container has a definite volume and cannot be compressed.

- 19 In which of the following circuit(s) will the bulb light up?

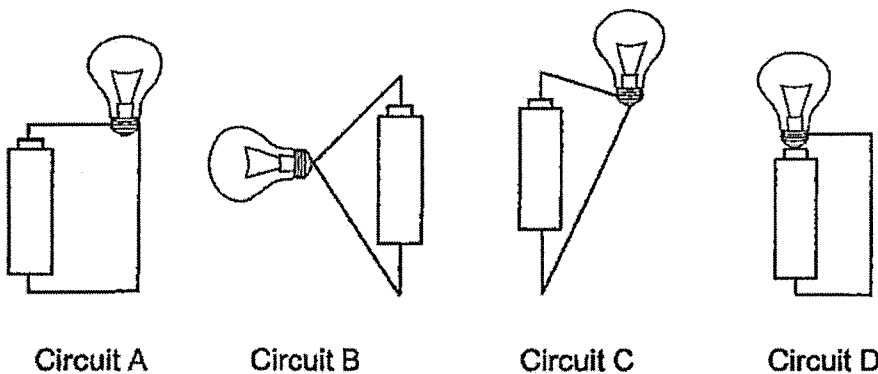

- (1) C only
- (2) A and B only
- (3) B and C only
- (4) C and D only

- 20 Three objects, X, Y and Z, which were made of different materials, were glued together and hung between a lit torch and a screen as shown below.

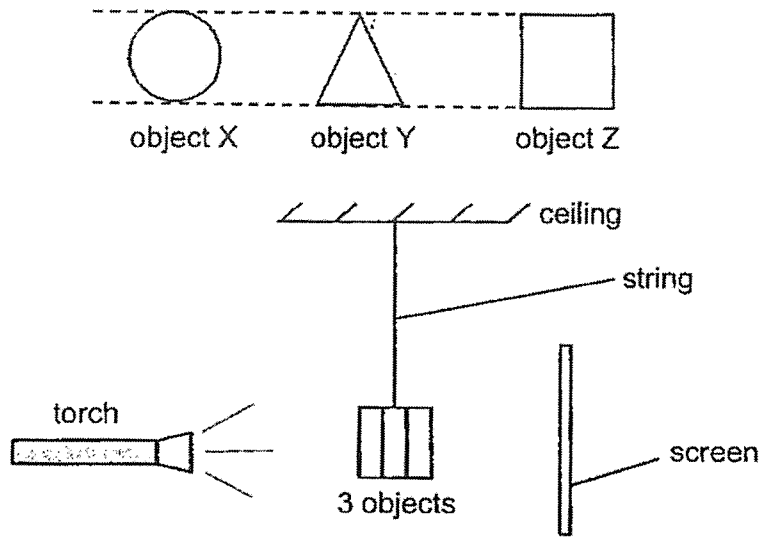

The diagram below shows the shadow formed on the screen.



Which of the following correctly matches each material to its possible use?

	Lenses of sunglasses	Fish tank	Toilet door
(1)	X	Y	Z
(2)	Y	Z	X
(3)	Z	X	Y
(4)	Z	Y	X

- 21 What is the purpose of the gaps in between railway tracks?

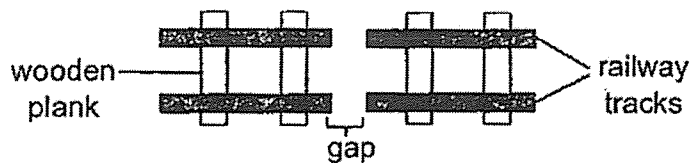

- (1) The gaps provide space for the tracks to expand on a hot day.
- (2) The gaps provide space for the tracks to contract on a cold day.
- (3) The gaps reduce friction between the train and tracks so that the train can travel faster.
- (4) The gaps allow heat generated on the tracks to be lost to the surrounding air faster.

- 22 Four similar metal blocks, each at $90\text{ }^{\circ}\text{C}$, were placed into four beakers of water as shown below. The beakers contained different amount of water at different temperatures at first.

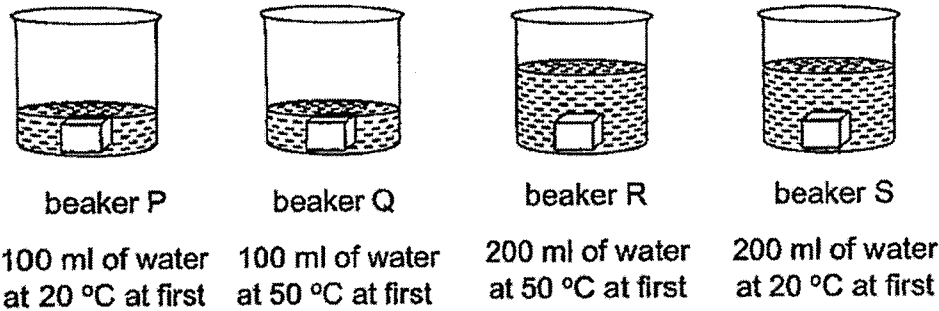

Which of the following statement(s) is/are correct after each metal block was placed into its beakers?

- A All the metal blocks lost heat to the water in each beaker.
- B The temperature of water in beaker Q will remain at $50\text{ }^{\circ}\text{C}$.
- C The water in beaker P will gain heat and reach $21\text{ }^{\circ}\text{C}$ faster than the water in beaker S.
- D The water in all the beakers will increase to $90\text{ }^{\circ}\text{C}$ before cooling to room temperature eventually.

- (1) A only
- (2) A and C only
- (3) B and D only
- (4) A, C and D only

- 23 Which of the following is not a source of potential energy?

- (1) a compressed spring
- (2) wind turning a windmill
- (3) fuel in an engine of a car
- (4) water stored behind a dam

24 Study the four set-ups below.

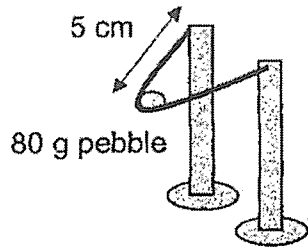

set-up J

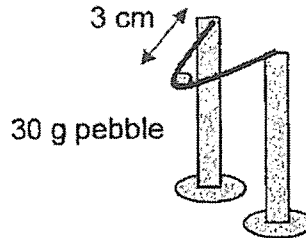

set-up K

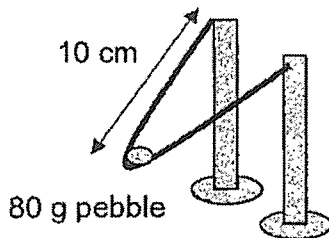

set-up L

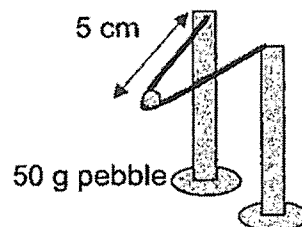

set-up M

An investigation to find out if the length of a stretched rubber band affects the distance travelled by a pebble is to be carried out.

Which of the following set-ups are to be used for the investigation?

- (1) Set-up J and set-up L
- (2) Set-up J and set-up M
- (3) Set-up K and set-up L
- (4) Set-up K and set-up M

(Go on to the next page)

- 25 Sally wanted to find out the strength of four magnets, A, B, C and D, using the set-up shown below.

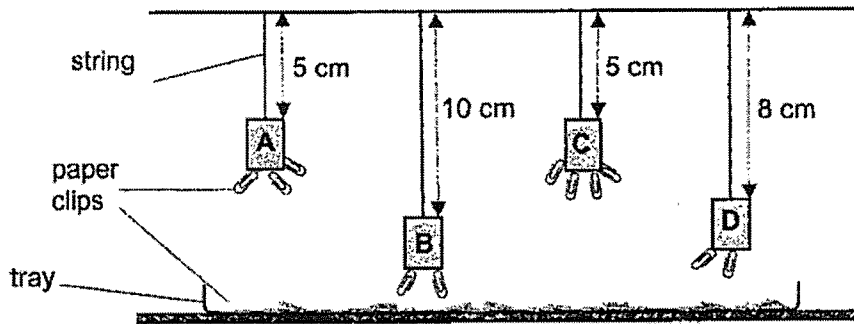

Which of the following correctly arranges the magnets from the strongest to the weakest?

- Strongest \longrightarrow Weakest
- (1) B, D, A, C
 (2) A, C, D, B
 (3) C, A, D, B
 (4) C, B, D, A

- 26 An iron ball was released from point X of a wooden ramp. A magnet was placed below point Y of the ramp. The ball rolled down the ramp before coming to a stop at point Z.

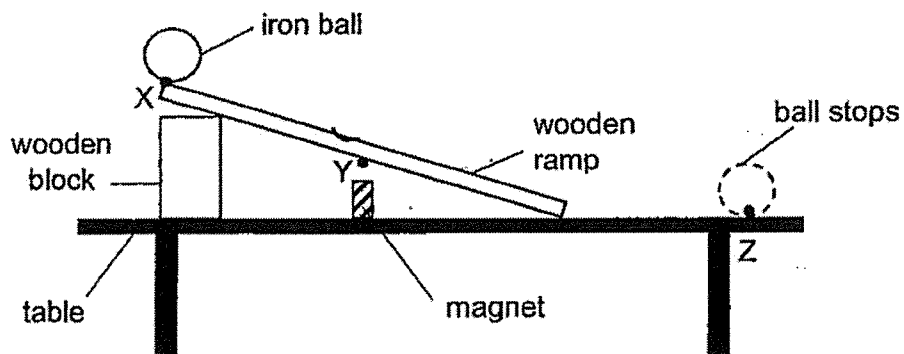

What is/are the force(s) acting on the ball at point Y?

- (1) Frictional force only
 (2) Frictional and magnetic forces only
 (3) Frictional and gravitational forces only
 (4) Frictional, gravitational and magnetic forces

- 27 A spring is stretched by a load. The load is then removed and the spring returns to its original length as shown below.

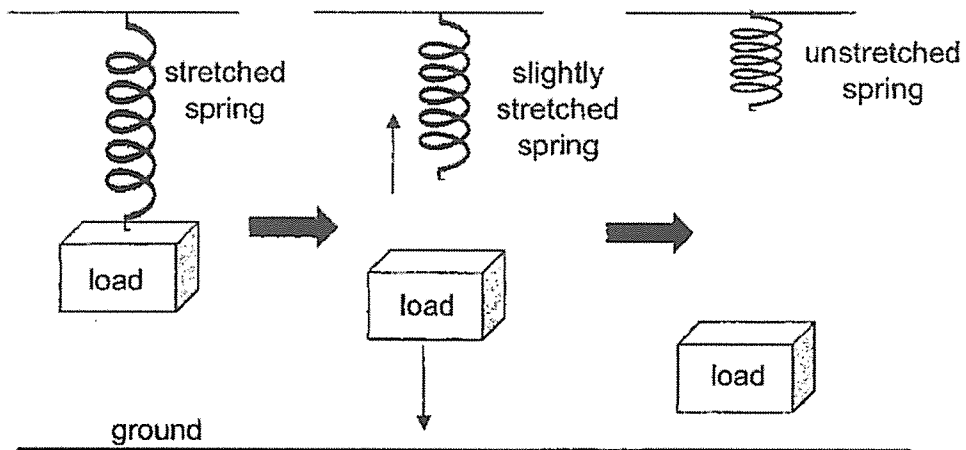

Which of the following shows the correct changes in the elastic spring force and gravitational force acting on the spring after the load is removed?

	Elastic spring force	Gravitational force
(1)	no change	decreasing
(2)	increasing	no change
(3)	decreasing	no change
(4)	decreasing	increasing

(Go on to the next page)

- 28 Three springs, E, F and G, have the same length but are made of different materials. When the springs are compressed by magnetic repulsion using six identical magnets, the results are as shown.

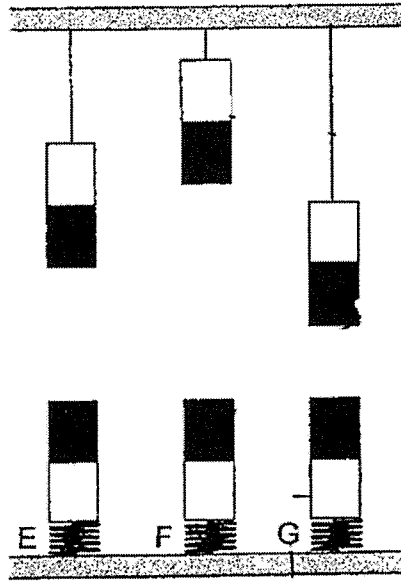

Which of the following correctly shows the relationship between the elastic spring force and the compression for springs E, F and G?

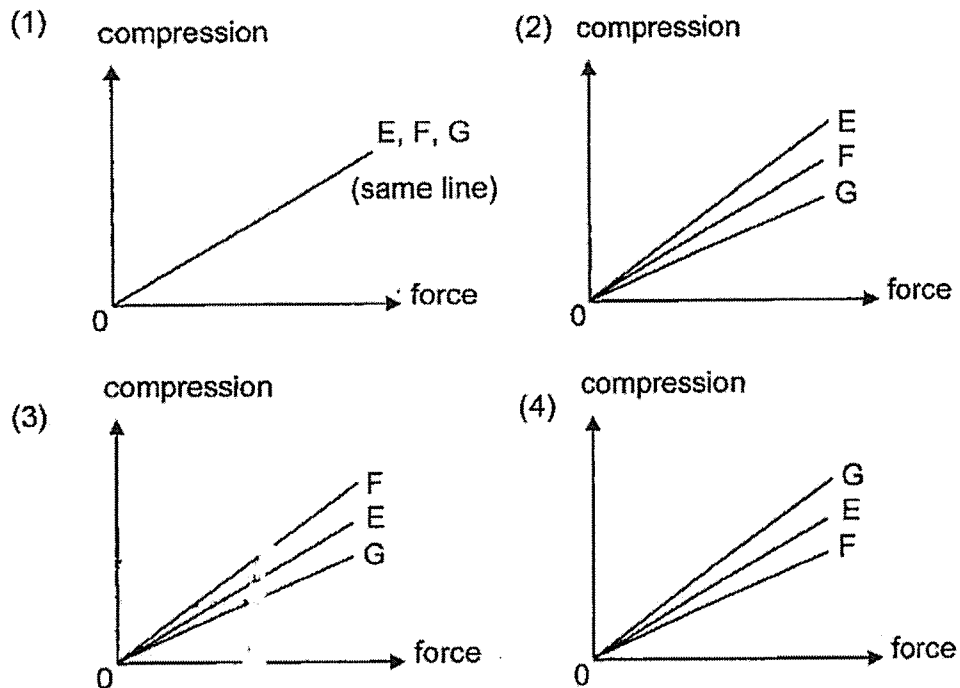



NAN HUA PRIMARY SCHOOL
TERM 2 NON-WEIGHTED ASSESSMENT 2023
PRIMARY 6
SCIENCE
BOOKLET B

12 Open-ended questions (44 marks)

Total Time for Booklets A and B: 1 hour 45 minutes

INSTRUCTIONS TO CANDIDATES

1. Write your name, index number and class in the spaces provided below.
2. Do not turn over the page until you are told to do so.
3. Follow all instructions carefully.
4. Answer all questions.
5. Use a dark blue or black ballpoint pen to write your answers in the space provided for each question.
6. Do not use correction fluid/tape or highlighters.

Marks Obtained

Section B

	/ 44
--	------

Name: _____ ()

Class: P 6 _____

Teaching Group: 6S _____

Date: 16th May 2023

Parent's Signature: _____

This booklet consists of 15 printed pages.

Section B: (44 marks)

For questions 29 to 40, write your answers in the spaces provided.

The number of marks available is shown in brackets [] at the end of each question or part question.

- 29 The graph below shows the amount of food an organism consumed in a 40-days period during its life cycle.

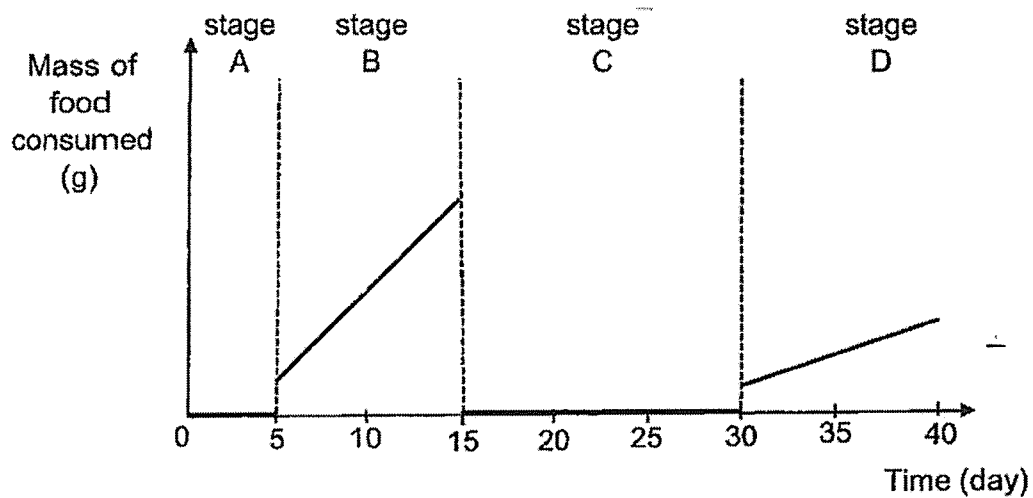

- (a) Name the stage in the life cycle of the organism at stage C. [1]

- (b) What is happening to the organism at stage C? [1]

- (c) How long did it take for the organism to develop into an adult? [1]

Score	3
-------	---

- 30 Henry prepared three identical set-ups, S, T and U, by burying 10 seeds in the same amount of soil. Then, he placed the three set-ups in three different locations. He gave each set-up the same amount of water every day. His observations over a period of 5 days were recorded in the table below.

Set-up	Surrounding temperature (°C)	Number of seeds germinated				
		Day 1	Day 2	Day 3	Day 4	Day 5
S	5	0	0	0	0	0
T	15	0	0	0	2	5
U	30	0	4	8	10	10

- (a) Based on the information above, what can Henry conclude about the effect of temperature on germination? [1]

- (b) Other than warmth and water, state one other factor that must be present for seeds to germinate. [1]

Go on to the next page

Henry also made observations on the mass of the seed leaves of one of the seedlings. He plotted a graph based on his observations as shown below.

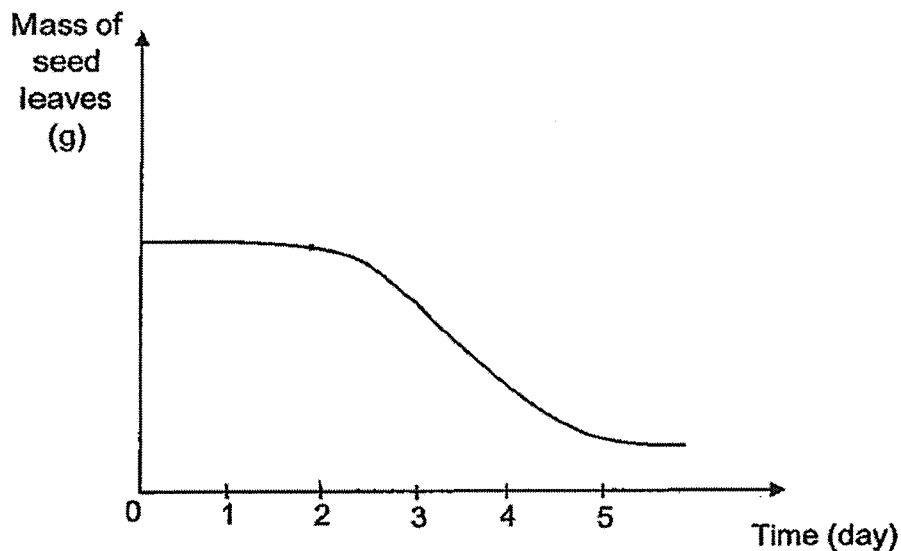

(c) What is the function of seed leaves? [1]

(d) Based on the table on page 3 and the graph above, which set-up, S, T or U, did Henry most likely choose the seedling from to observe its seed leaves? Give a reason for your answer. [2]

4

Score	5
-------	---

- 31 Linda ran in the park for 20 minutes. The graph below shows her breathing rate after she has stopped running.

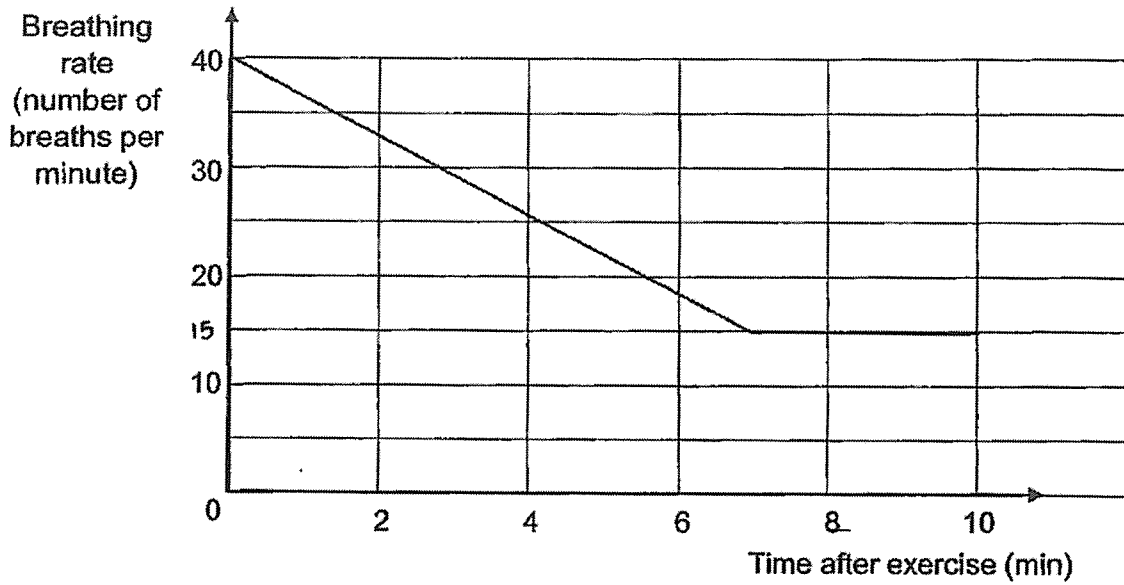

- (a) From the graph above, state Linda's normal breathing rate. [1]

- (b) Based on the graph above, explain what happened to Linda's breathing rate once she has stopped running. [2]

Go on to the next page

Score	
-------	---

- 32 Emily placed a water plant into a test tube and filled the test tube to the brim with water and substance A at the start of the experiment. She then covered it with a cap. A lit torch is placed 10 cm away from the test tube. A lit torch is placed 10 cm away from the test tube.

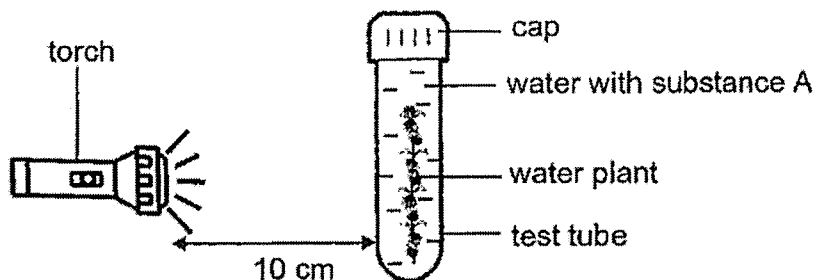

After 20 minutes, Emily measured and recorded the volume of gas X collected at the top of the test tube.

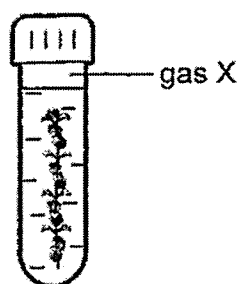

after 20 minutes

She then repeated the experiment with different amounts of substance A and plotted a graph based on the results obtained as shown below.

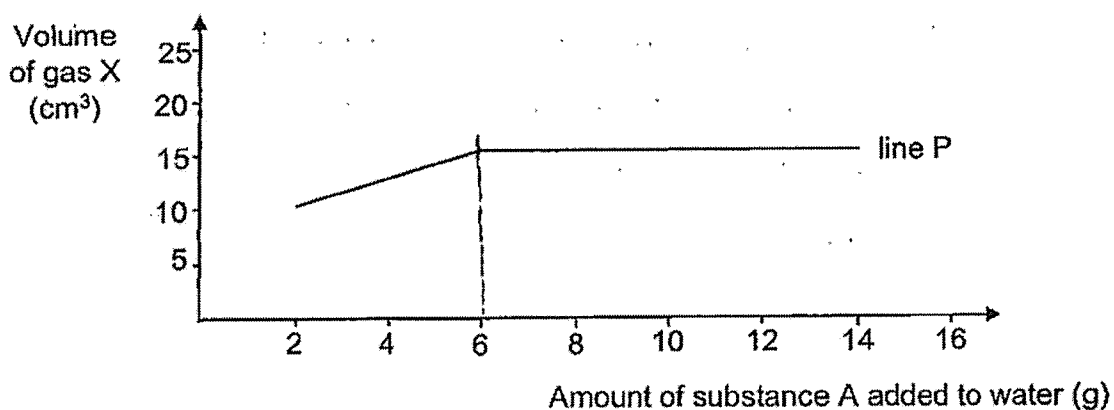

(a) What is gas X?

[1]

(b) Based on the graph above, what is the relationship between the amount of substance A added to the water and the rate of photosynthesis? [2]

Emily then made a change to her set-up without adding or removing any items. She conducted the same experiment again and obtained a new set of results as shown by line Q.

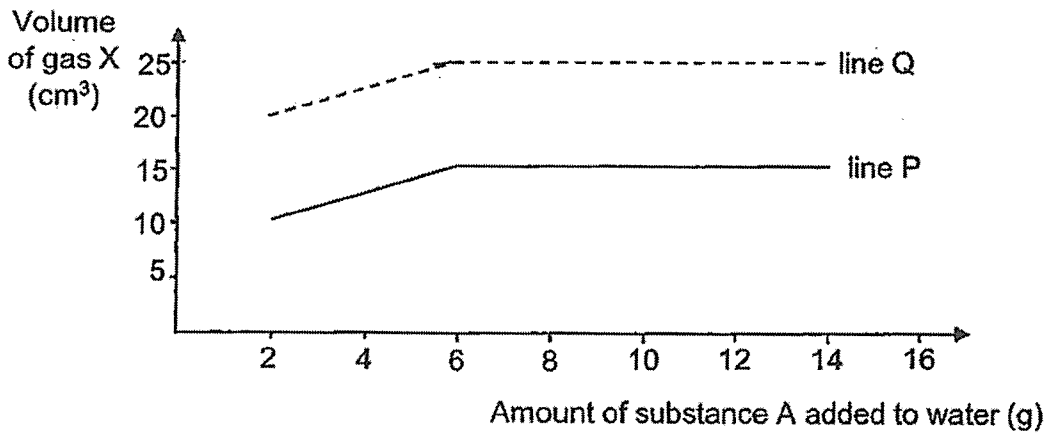

(c) Suggest a change that Emily could have made to the set-up to obtain the new results. [1]

Go on to the next page

Score	
	4

33 Some scientists conducted a study on the pond in a field as shown below.

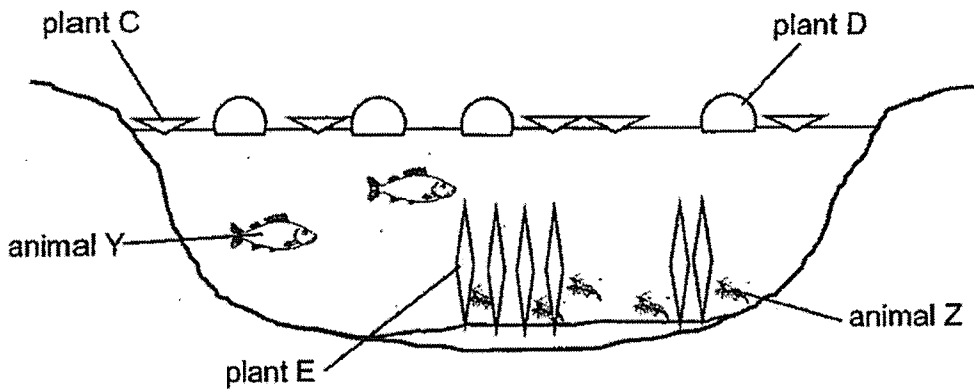

- (a) Plants C and D reproduce at a rate faster than plant E. After a while, plant E started dying. Explain why. [2]

The scientist found that as plant E started dying, the amount of bacteria in the pond started increasing. At the same time, the amount of oxygen in the pond started decreasing.

- (b) Give a reason how the increase in the amount of bacteria caused a decrease in the amount of oxygen in the pond. [1]

- (c) Animal Y feeds on animal Z. With more plant E dying, explain how this caused animal Z to be more easily preyed on by animal Y. [1]

Score	4
-------	---

34 Study the food chain below carefully. The food chain is found in habitat T.

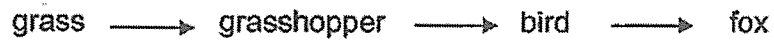

A disease caused the grass in habitat T to start dying.

- (a) After a while, the population of the birds in habitat T started decreasing. Explain why. [2]

Another food chain that is found in habitat T is shown below.

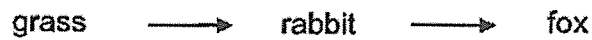

- (b) In the box below, construct a food web using the two food chains found in habitat T above. [1]

Go on to the next page

Score	3
-------	---

35 Some liquid was poured into a communicating vessel (container) as shown below.

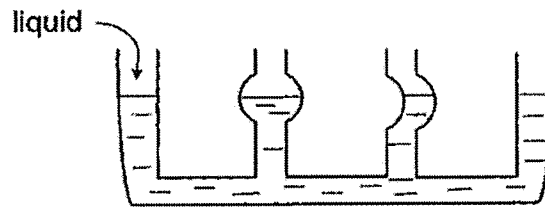

(a) What property of liquid is shown in the diagram above? [1]

Susie wanted to make a cup of bubble tea. She filled a measuring cup with some pearls until the 100 ml mark as shown below.

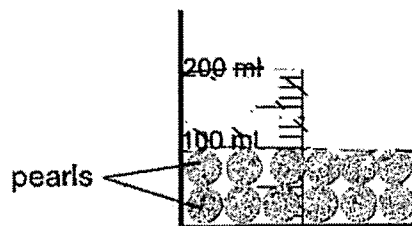

(b) How much tea should Susie pour in to fill the cup to 200 ml? Tick [✓] the box beside your choice. [1]

- Exactly 100 ml
- More than 100 ml but less than 200 ml
- Exactly 200 ml

(c) Give a reason for your answer to part (b) above. [1]

(d) Suzie put some ice cubes carefully into her bubble tea and some tea overflowed from the cup. Explain why this happen. [1]

Score			4
-------	--	--	---

36 P, Q and R represent the three states of water.

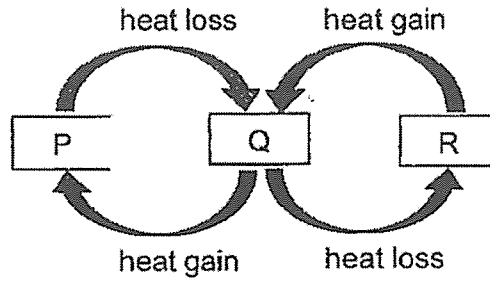

(a) Fill in the blanks below. [1]

(i) P: _____

(ii) R: _____

The set-up below was placed under the hot sun for two hours.

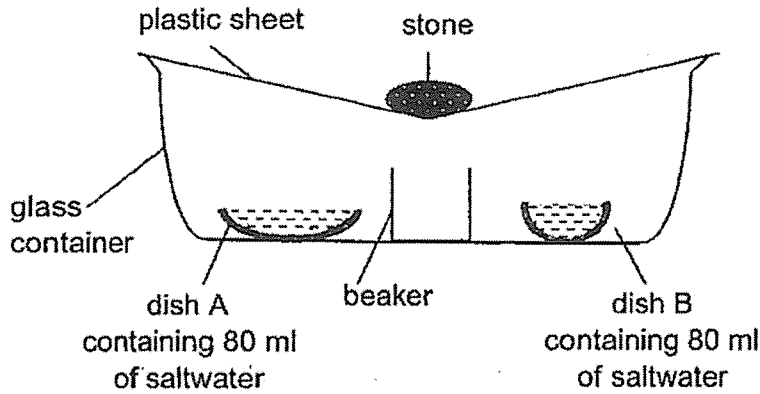

(b) Why was there less saltwater in dish A compared to dish B after two hours? [1]

(c) Explain how fresh water was collected in the beaker after two hours. [2]

Go on to the next page

Score	4
-------	---

- 37 A bucket of water is placed above a thin metal sheet. A hole at the bottom of the bucket allows water to drip and land on the metal sheet, producing a sound.

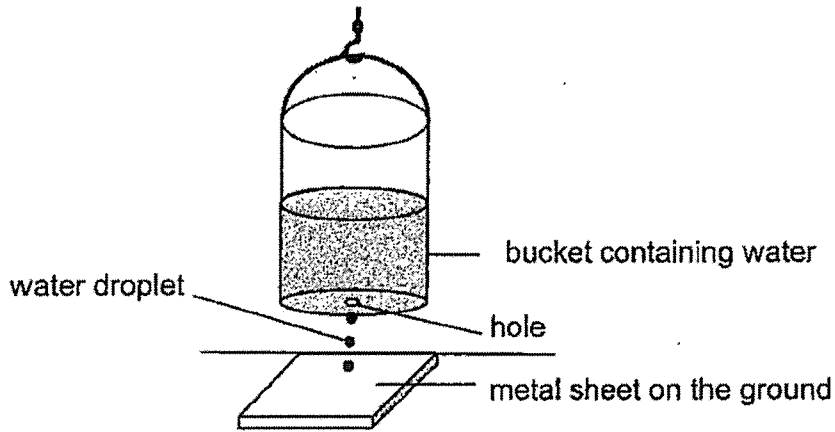

- (a) State the main energy changes for the water after leaving the bucket and landing on the metal sheet. [1]

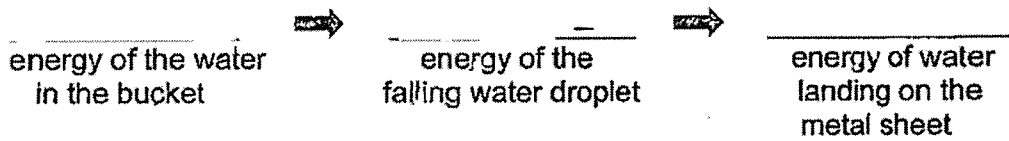

- (b) When the hole in the bucket is enlarged, the sound produced will be louder. In terms of energy conversion, explain why this is so. [2]

- (c) Without changing the size of the hole, suggest another way to produce a louder sound with the set-up above. [1]

Score	4
-------	---

- 38 Minli set up two circuits, A and B. She connected a battery and a bulb in each circuit. She then recorded the brightness of each bulb in the graph below. Minli then increased the number of bulbs used, one at a time, with different arrangement of the light bulbs in the two circuits.

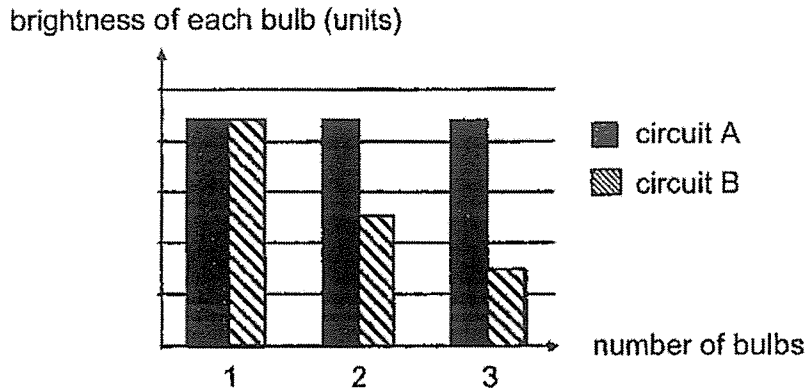

- (a) State the relationship between the brightness of each bulb and the number of bulbs used in circuit A. [1]

- (b) Based on the graph above, use circuit symbols to complete circuit B below by including three bulbs to show how they were arranged. [1]

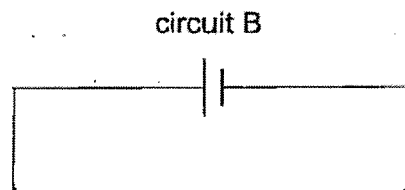

- (c) Other than the brightness of the bulbs, state another advantage of circuit A's arrangement of bulbs compared to that of circuit B's. [1]

Go on to the next page

Score	3
-------	---

- 39 Study the circuit shown in diagram 1.
Diagram 2 shows what happens when both switches, S1 and S2, are closed.

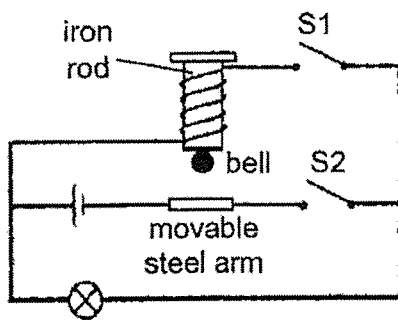

diagram 1

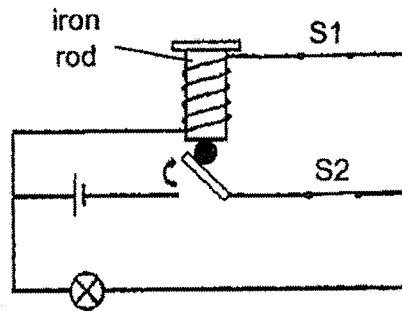
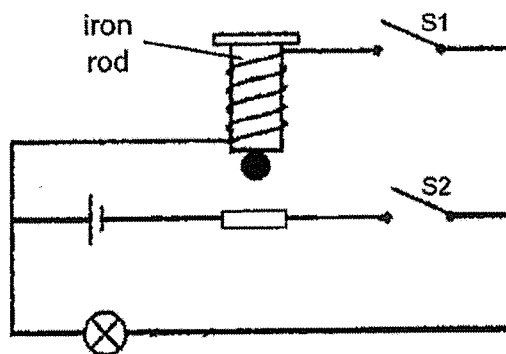

diagram 2

- (a) What would be observed if only S2 is closed? [1]

- (b) Explain how the bell sound is produced when both switches are closed. [2]

- (c) Mark with a cross (X), along a wire in the diagram below, where another battery can be positioned to make the bulb shine more brightly. [1]



Score	4
-------	---

- 40 Four identical wooden cubes were each tied to a similar pail and placed on a different surface, A, B, C and D, as shown below.

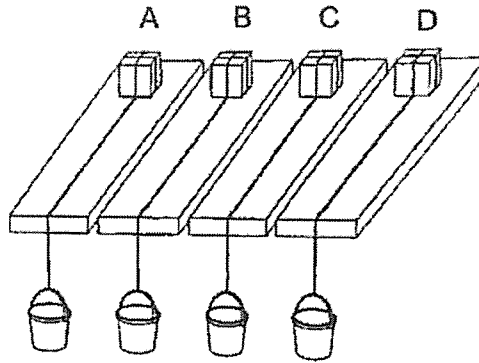

A 50 g mass was added (one at a time) into each pail until the wooden cube can slide off completely from the surface. The table below shows the results.

	Surface A	Surface B	Surface C	Surface D
Number of 50 g mass added	10	5	15	10

- (a) What force do each wooden cube need to overcome in order to slide off the surface? [1]

- (b) Based on the results, arrange the surfaces, B, C and D, from the smoothest to the roughest. [1]

Surface A is supposed to be smoother than surface D, yet the experiment could not tell them apart.

- (c) Suggest a change to improve the accuracy of the experiment. [1]

Score	3
-------	---

End of Paper

NAN HUA PRIMARY SCHOOL
NWA2 2023
PRIMARY SIX
SCIENCE
Answer Key (students' copy)

Section A

Qns	Ans	Qns	Ans	Qns	Ans
1	4	11	3	21	1
2	3	12	4	22	2
3	4	13	4	23	2
4	2	14	2	24	1
5	1	15	4	25	3
6	4	16	1	26	4
7	3	17	4	27	3
8	3	18	2	28	3
9	1	19	4		
10	4	20	4		

Section B

Qns	Answer
29a	Pupa stage
29b	The young / larva is developing / turning / changing into / becoming an adult. OR The young / pupa does not eat. OR The young / pupa stops feeding.
29c	30 days
30a	The higher the (surrounding) temperature, the earlier the seeds germinated. OR As/ When the temperature increases, the number of seeds germinated increases. OR Seeds need warmth to germinate. OR Seeds cannot germinate at 5°C.
30b	Oxygen/ Air
30c	Seed leaves provide food/contains stored food for the developing seedling before the true / first leaves unfold / appear. OR Seed leaves provide food/contains stored food so that the seedling can grow its first roots and shoots before the true / first leaves unfold / appear.
30d	Set-up U. The mass of seed leaves started decreasing from day 2 which means that the seedling has started using the food stored in the seed leaves to

	germinate / grow. Set-up U is the only set-up which has seeds germinating from day 2.
31a	15 breaths per minute
31b	Her breathing rate decreases/started decreases she started breathing slower as her body needs less oxygen to release less energy.
32a	Oxygen
32b	As the amount of substance A added to the water increases, the rate of photosynthesis increases until 6g. As the amount of substance A increases from 6g onwards, the rate of photosynthesis stays the same.
32c	She moved the torch closer to the test tube / water plant. OR Decrease the distance between the torch and the test tube. OR Make the distance between the torch and the test tube less than 10 cm.
33a	Plants C and D reproduced and take up / occupied (more of) the surface of the pond, preventing light from reaching plant E / less light reaches plant E. Plant E cannot make food / made less food and some plant E died. OR There are more plants C and D which blocked / prevented light from reaching plant E, causing plant E to make less food / photosynthesise less / have a lower rate of photosynthesis and some plant E died.
33b	Bacteria take in oxygen as they are living things / for respiration. OR Bacteria respired.
33c	Animal Y can spot animal Z more easily without plant E hiding them. OR Animal Z has less places to hide from animal Y.
34a	With less/no grass to feed on, some grasshoppers will die and the population of grasshopper will decrease. There will less food for the birds so they will fly / move away / die.
34b	<pre> graph LR grass --> grasshopper grass --> rabbit grasshopper --> bird bird --> fox rabbit --> fox </pre>

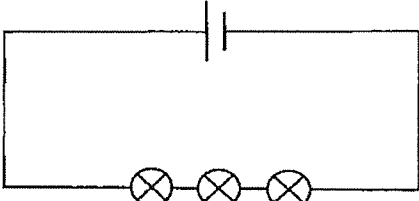
35(a)	Liquid has no definite / fixed shape / takes the shape of its container.
35(b)	Tick ✓ More than 100 ml but less than 200ml
35(c)	The volume of pearls is less than 100ml, there are still some spaces between the pearls that can be filled up by the tea.
35(d)	The ice cubes took up space in the cup previously occupied by the tea that had overflowed. OR Ice cubes took up more space than the cup (with tea) allows. Some tea overflows to make space for the ice cubes.
36a	(i) P : Water vapour / Gas / Gaseous state (ii) R : Ice / Solid
36b	Dish A is wider than dish B. Hence, the exposed surface area of saltwater in dish A is greater, allowing a faster rate of evaporation of water from dish A.
36c	Water from both dishes gained heat from the sun / surroundings and evaporated into water vapour. The water vapour rose, lost heat and condensed on the cooler inner plastic sheet to become water droplets which then fell into the beaker. OR Water from both dishes gained heat from the sun / surroundings and evaporated into water vapour. The warm water vapour rose, lost heat and condensed on the cool inner plastic sheet to become water droplets which then fell into the beaker.
37a	(Gravitational) Potential → Kinetic → Sound
37b	A greater mass/ larger falling water droplet can now pass through the enlarged hole, hence, possessing more gravitational potential energy to be converted to more kinetic energy of the falling water droplet, which in turn, is converted into more sound energy to cause a louder sound upon hitting the sheet.
37c	Lift / move the bucket of water up / upwards/ higher above the ground / metal sheet.
38a	As number of bulbs used in circuit A increases, the brightness of each bulb remains unchanged / stays as bright as before.
38b	<p style="text-align: center;">circuit B</p> 

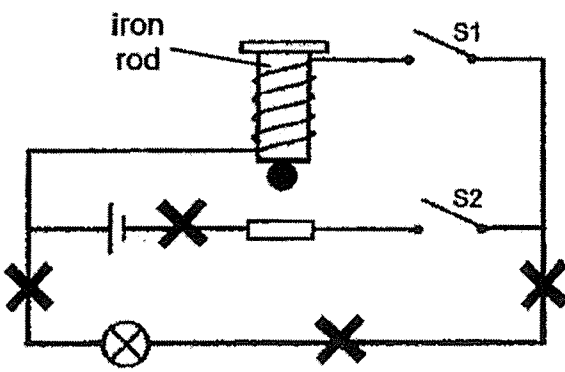
38c	When a bulb fuses in circuit A, the rest of the bulbs remain lit but when a bulb fuses in circuit B, none of the bulbs can light up.
39a	The bulb will light up.
39b	When both switches are closed, electric current will pass through the circuit and magnetised the iron rod / cause iron rod to become an electromagnet. The movable steel arm will be attracted to the iron rod / electromagnet and strike/hit the bell, making a sound.
39c	To mark a cross anywhere along wire of the "bottom" loop. 
40a	Frictional force / friction
40b	B, D, C
40c	Use loads / masses that are lower / smaller than 50 g each to be placed into the pails instead.