

METHODIST GIRLS' SCHOOL  
Founded in 1887



WEIGHTED ASSESSMENT 2 2023  
PRIMARY 6  
SCIENCE

Total Time for Section A and B: 45 minutes

**INSTRUCTIONS TO CANDIDATES**

Do not turn over this page until you are told to do so.  
Follow all instructions carefully.  
Answer all questions.

Name: \_\_\_\_\_ ( )

Class: Primary 6. \_\_\_\_\_

Date : \_\_\_\_\_ May 2023

Section A	20
Section B	15
<b>Total</b>	<b>35</b>
Parent's Signature	

This booklet consists of 14 printed pages including this page.

**Section A**

For each question from 1 to 10, four options are given. One of them is the correct answer. Make your choice (1, 2, 3 or 4) and write in the bracket provided. [20 marks]

- 1 A group of scientists studied the conditions in two different habitats, A and B. Their observations were recorded in the table below.

Conditions	Habitat A	Habitat B
Amount of light	dim	very bright
Amount of water	a lot	little
Temperature of surroundings (°C)	20 – 22	31 – 35

Animal W can be found in Habitat A while animal X can be found in Habitat B. The scientists placed ten animal W and ten animal X at the centre of a square container with conditions in each part as shown below.

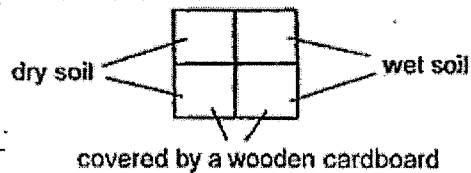

Which one of the following shows the most likely number of animals in each section of the container after some time?

	Animal W	Animal X								
(1)	<table border="1"> <tr><td>8</td><td>2</td></tr> <tr><td>0</td><td>0</td></tr> </table>	8	2	0	0	<table border="1"> <tr><td>0</td><td>0</td></tr> <tr><td>1</td><td>9</td></tr> </table>	0	0	1	9
8	2									
0	0									
0	0									
1	9									
(2)	<table border="1"> <tr><td>0</td><td>0</td></tr> <tr><td>1</td><td>9</td></tr> </table>	0	0	1	9	<table border="1"> <tr><td>9</td><td>0</td></tr> <tr><td>1</td><td>0</td></tr> </table>	9	0	1	0
0	0									
1	9									
9	0									
1	0									
(3)	<table border="1"> <tr><td>1</td><td>9</td></tr> <tr><td>0</td><td>0</td></tr> </table>	1	9	0	0	<table border="1"> <tr><td>0</td><td>9</td></tr> <tr><td>0</td><td>1</td></tr> </table>	0	9	0	1
1	9									
0	0									
0	9									
0	1									
(4)	<table border="1"> <tr><td>0</td><td>0</td></tr> <tr><td>0</td><td>10</td></tr> </table>	0	0	0	10	<table border="1"> <tr><td>0</td><td>9</td></tr> <tr><td>1</td><td>0</td></tr> </table>	0	9	1	0
0	0									
0	10									
0	9									
1	0									

( )

(Go on to the next page)

2 Kamal studied the food relationships among four organisms, P, Q, R and S, living in the same habitat. He wrote some notes in his Science journal as shown below.

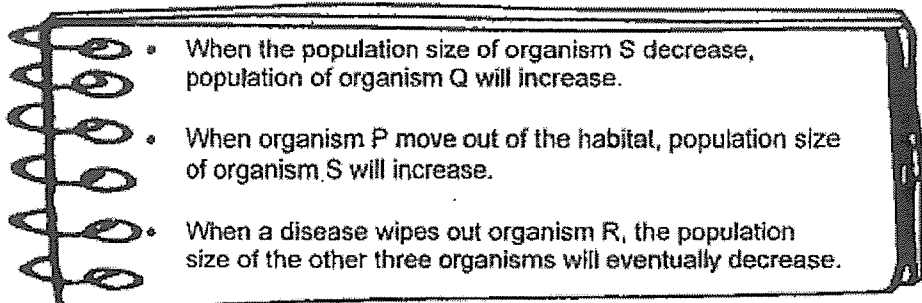

Based on Kamal's notes, which one of the following food chains is correct?

- (1) P → S → Q → R
- (2) P → Q → S → R
- (3) Q → S → R → P
- (4) R → Q → S → P

( )

3 The flowchart below shows some organisms, W, X, Y and Z, in a community.

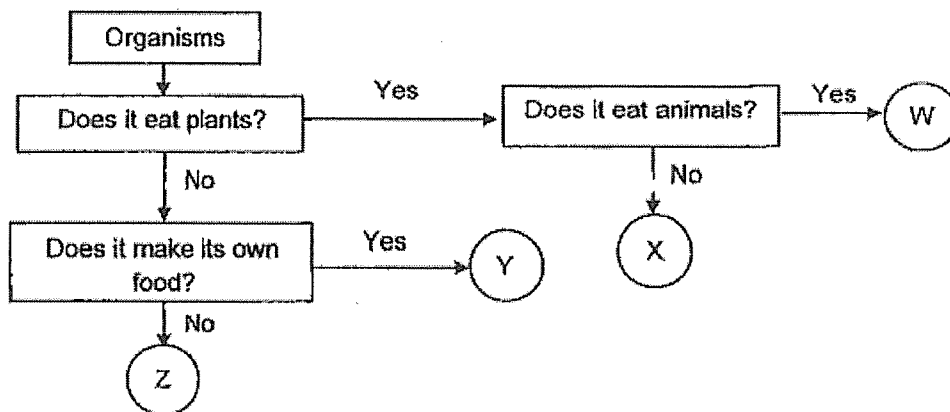

Which one of the following food webs can be correct?

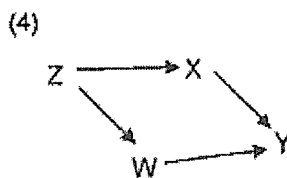
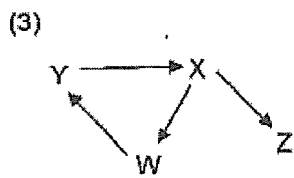
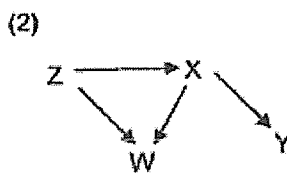
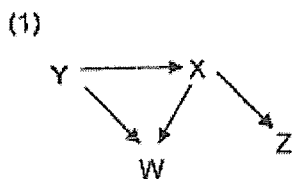

( )

(Go on to the next page)

- 4 The food web below shows the relationships among some organisms within a pond community.

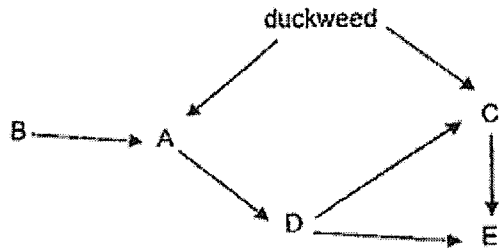

Which one of the following graphs correctly shows how the populations of B, C, D and E will be affected if the population of A decreases?

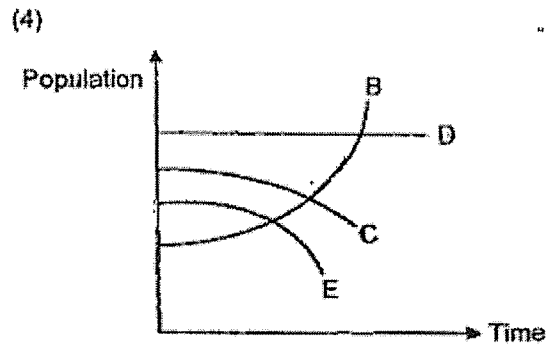
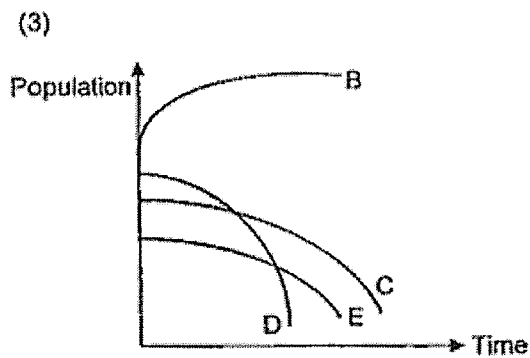
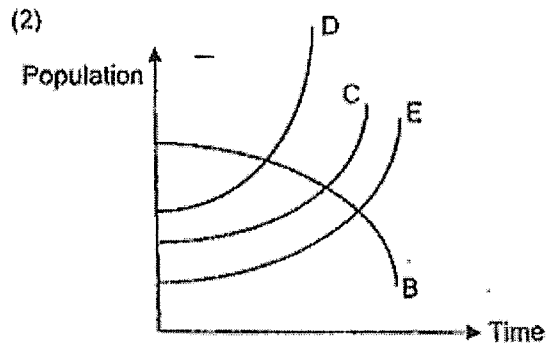
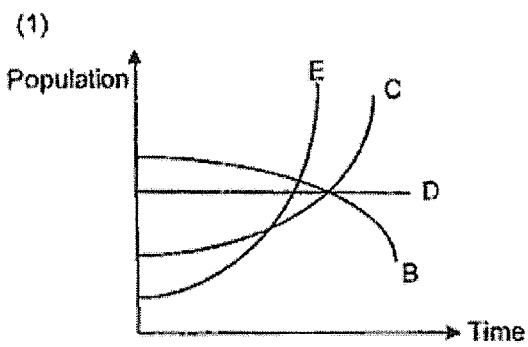

( )

(Go on to the next page)

- 5 Saanvi prepared the set-up below to study the decomposition of dead leaves.

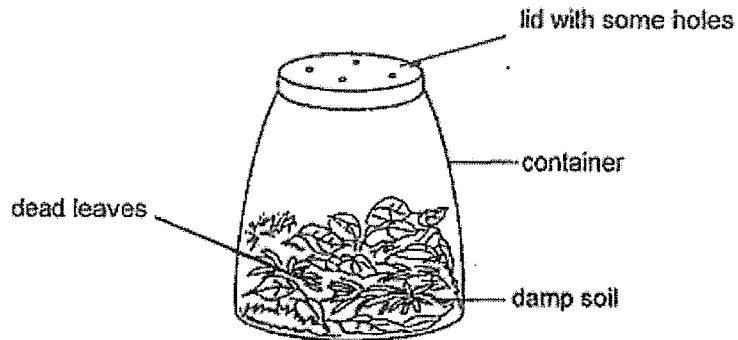

After two months, she observed that the dead leaves turned into a *slimy* black substance. Saanvi wrote the following statements:

- A During decomposition, oxygen escapes from the container.
- B The presence of water allowed decomposers to break down the dead leaves.
- C The presence of carbon dioxide allowed decomposers to break down the dead leaves.

Which statement(s) about decomposition is/are correct?

- (1) B only
- (2) A and B only
- (3) A and C only
- (4) B and C only

( )

(Go on to the next page)

- 6 During a game on an icy surface, a player uses a stick to hit a puck across the surface. When more players skate across the icy surface, the ice melts faster.

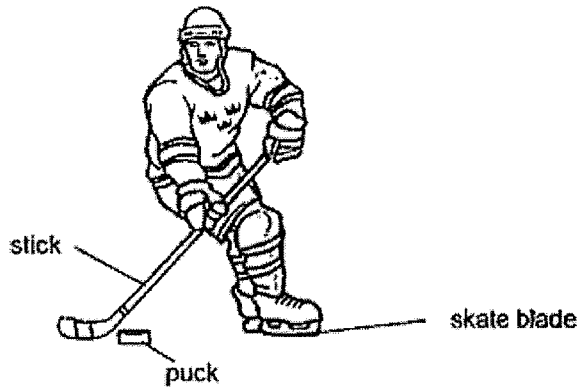

The table below shows four practice rounds which the player took part in.

Round	Number of players who skated	Condition of icy surface during practice round
1	6	Smooth
2	6	Rough
3	10	Smooth
4	10	Rough

During which round would the puck travel the furthest distance when the player hit it with the same amount of force?

- (1) Round 1
- (2) Round 2
- (3) Round 3
- (4) Round 4

( )

(Go on to the next page)

- 7 At a carnival, Jaelyn used a catapult to hit a tower of metal cans with a rubber ball. When she pulled the elastic strap back and released the ball, it hit a can causing it to be dented. The ball and some cans fell onto the ground.

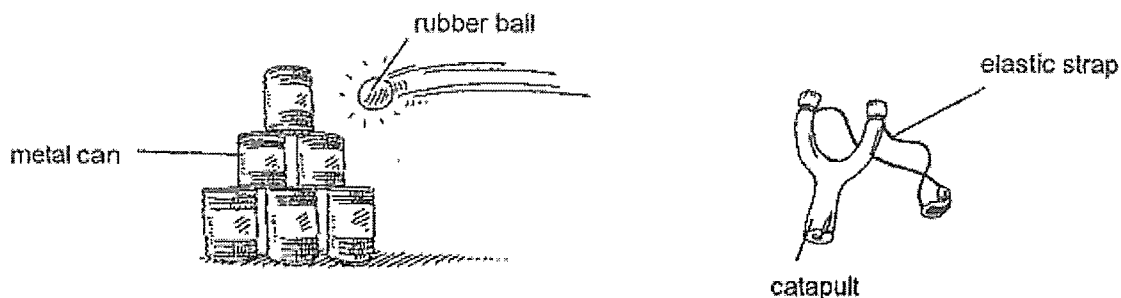

Based on the above, which of the following about forces can be concluded?

- A A force can move an object at rest.  
 B A force can change the shape of an object.  
 C The ball fell onto the ground as there was no more force acting on it

- (1) A only  
 (2) A and B only  
 (3) A and C only  
 (4) B and C only

( )

- 8 The diagram below shows object J attached to a spring. When object H is brought near to object J, it is observed that object J moved as shown in the diagram below.

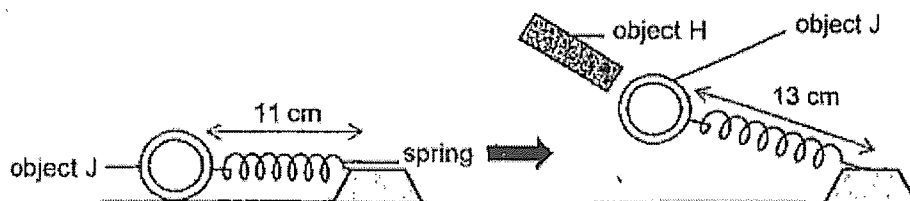

Which of the following statements is/are correct when object H is brought towards object J?

- A Less gravitational force acts on object J.  
 B Magnetic force of repulsion acts on object J.  
 C Elastic spring force exerted by the spring increases.  
 D The length of the spring increases as the compressed spring exerts a push force.

- (1) C only  
 (2) A and B only  
 (3) C and D only  
 (4) A, B and D only

( )

(Go on to the next page)

- 9 Allison carried out an experiment using springs P and Q. Both springs have the same original length. She hung 100 g masses on each spring and repeated the experiment using 200 g masses as shown in the diagrams below.

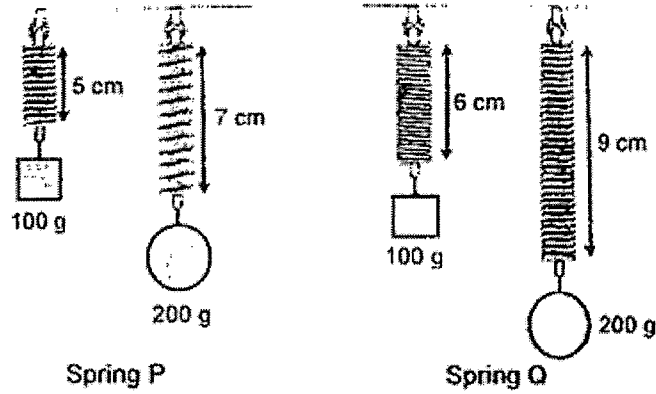

Based on the results above, which one of the following graphs is correct?

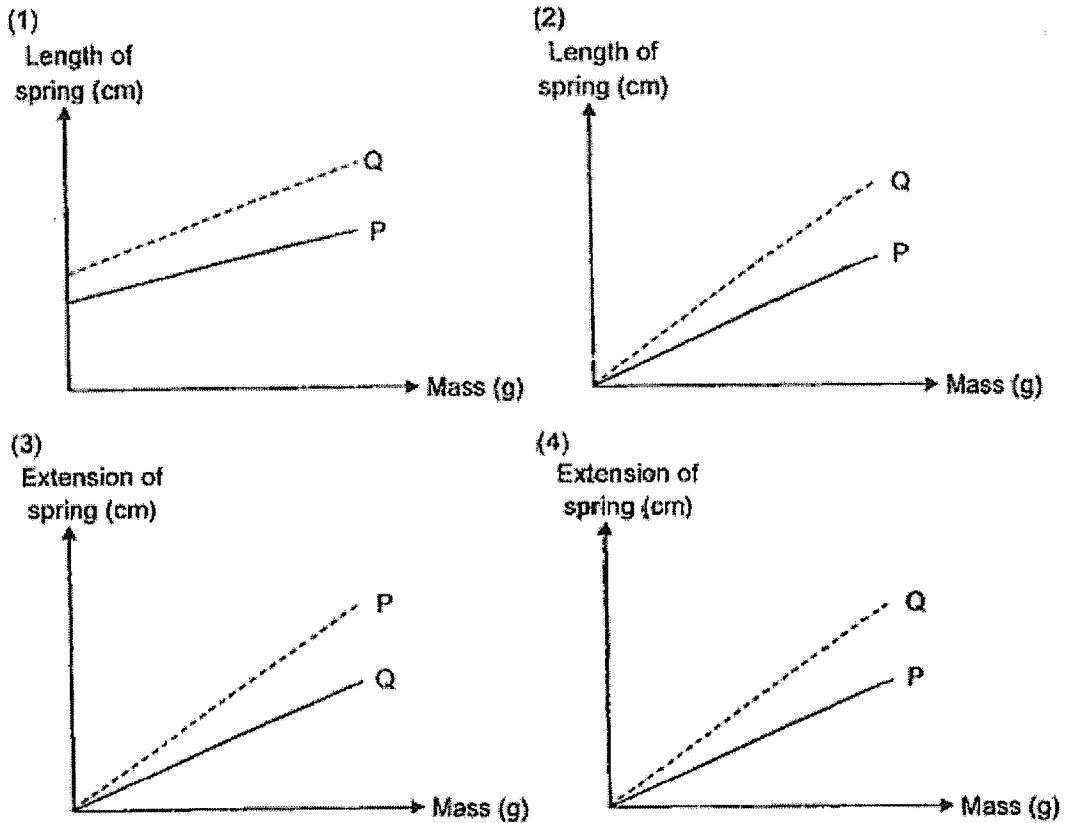

( )

(Go on to the next page)



10 Lucas and his friend are playing on a see-saw.

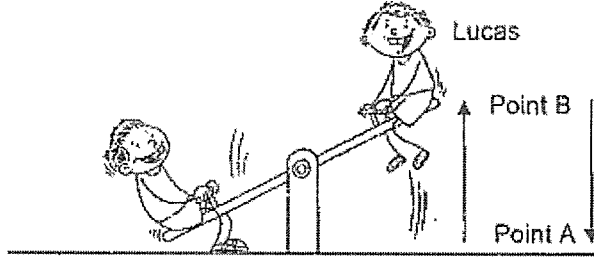

Which one of the following graphs shows the amount of gravitational force acting on Lucas as he moves from Point A to Point B and back to Point A?

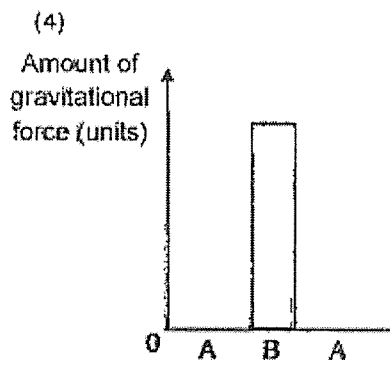
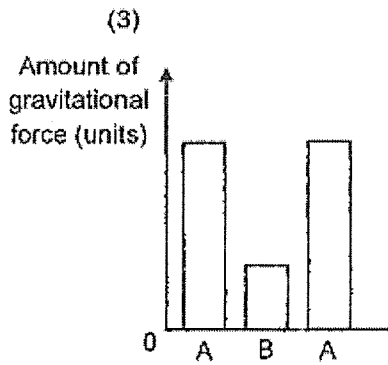
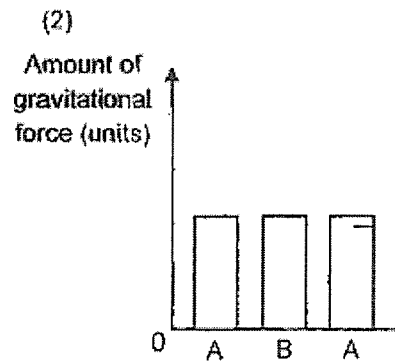
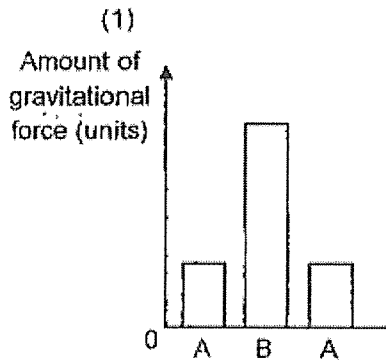

( )

(Go on to the next page)

**Section B**

For questions 11 to 14, write your answer in the spaces provided.

[15 marks]

- 11 A farmer used a fenced structure to grow organism X and plant Z as shown in diagram 1. Diagram 2 shows organism X. When sea water passes through organism X, its gills will trap the large particles containing food and then release the clearer water into the sea water. Organism X does not grow well in water containing high amount of carbon dioxide.

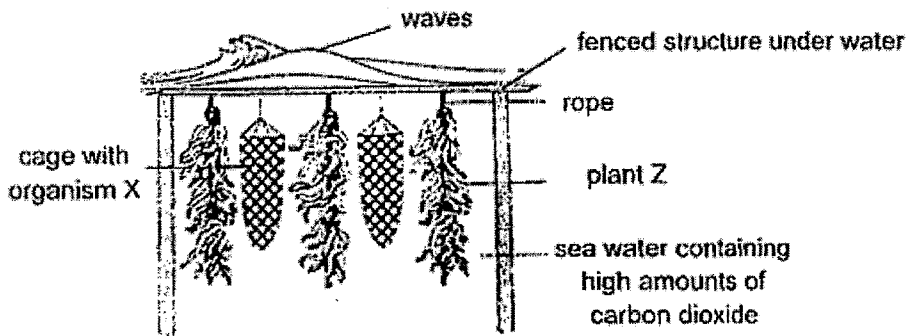

Diagram 1



Diagram 2

- (a) Other than strength, state another property of the material which the rope is made of so that it is suitable to be used in sea water with strong waves. [1]

\_\_\_\_\_

- (b) State one way how the presence of plant Z benefits the growth of organism X. [2]

\_\_\_\_\_  
 \_\_\_\_\_  
 \_\_\_\_\_

- (c) The farmer observed that at first, the sea water was murky. But after a few weeks, it became clearer. Explain how plant Z benefits from growing near to organism X. [1]

\_\_\_\_\_  
 \_\_\_\_\_

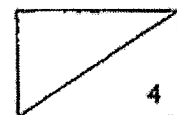

(Go on to the next page)

- 12 Jane visited an aquarium and saw a sign showing a food web of organisms in a tank as shown below.

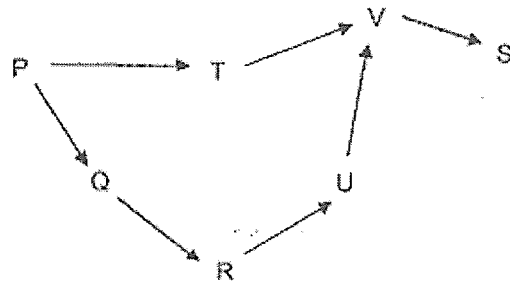

A guide told her that a recent disease outbreak caused the population of organism R to decrease significantly.

- (a) Identify the two organisms that would be directly affected when organism R decreased significantly. Explain your answer. [2]

---



---



---

Jane recorded the different observations about organisms A, B, C, D and E in her home aquarium.

- B and D are plants.
- C feeds on D.
- E feeds on B and C.
- C and E are eaten by A

- (b) Based on her observations, complete the food web below by filling in the boxes with organisms A, B, C, D and E. [2]

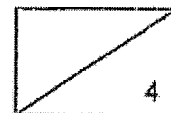
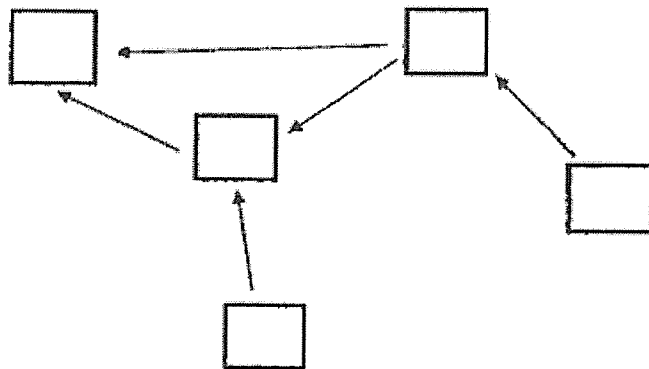

(Go on to the next page)

- 13 Ariana released a marble from the top of a ramp and it rolled down as shown in the diagram below.

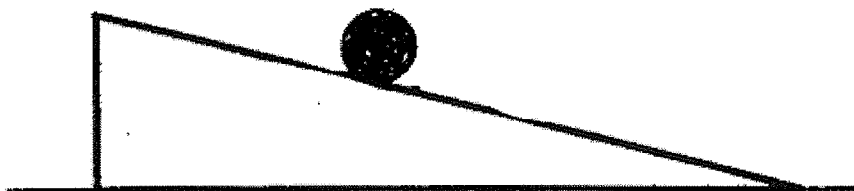

- (a) In the diagram above, draw and label <sup>one</sup> ~~two~~ arrow(s) showing the direction of gravitational force and direction of frictional force acting on the marble. [1]

Ariana then conducted an experiment in which she placed three identical marbles at the top of three ramps of the same size, J, K and L, before releasing them from the same height. Ramps K and L are fixed with a different number of raised strips as shown in the diagram below.

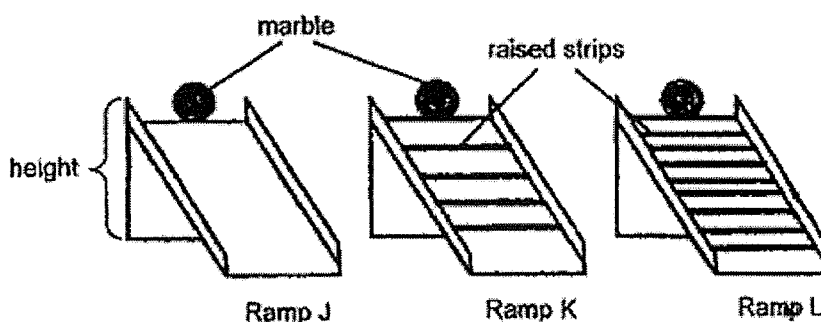

She recorded the time taken for each marble to reach the bottom of the ramp in the table below.

Ramp	Time taken for the marble to reach the bottom of the ramp (s)
J	3
K	5
L	8

- (b) State a possible hypothesis that Ariana wanted to test. [1]

---



---

(Go on to the next page)

- (c) She applied a layer of oil on the surface of ramp J before releasing the marble. Will the marble take a shorter, longer or the same time to reach the bottom of the ramp? Explain your answer in terms of energy changes. [2]

---

---

---

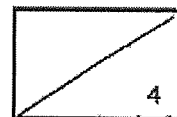

(Go on to the next page)

- 14 Cleo attached a magnet to a retort stand and observed that the paper clip was 'floating' as shown in Diagram 1. After she moved the magnet to a greater height, the paper clip dropped to the ground as shown in Diagram 2.

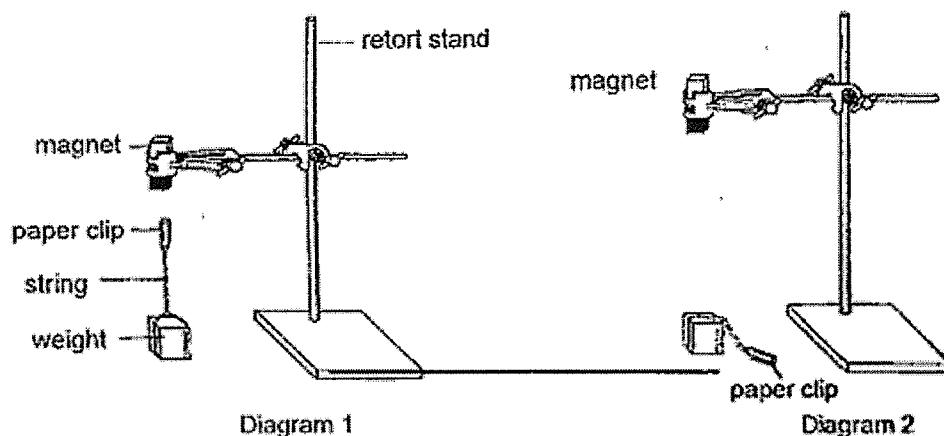

- (a) State the force(s) acting on the paper clip when it was 'floating' in the air. [1]

---

- (b) If Cleo replaced the paper clip with a copper clip, would her observation in Diagram 1 be the same? Explain why. [1]

---



---

- (c) Explain why the paper clip dropped to the ground when the magnet was moved to a greater height. [1]

---



---



END OF PAPER

**METHODIST GIRLS' SCHOOL (PRIMARY)**  
**SCIENCE WEIGHTED ASSESSMENT 2 2023**  
**PRIMARY 6**  
**ANSWER KEY**

**Section A (10 X 2m = 20 marks)**

1.	2	6.	3
2.	4	7.	2
3.	1	8.	1
4.	3	9.	4
5.	1	10.	2

**Section B (15 marks)**

Qn	Acceptable Answers
11 (a)	Flexible
11 (b)	Plant Z takes in carbon dioxide during photosynthesis so there is less carbon dioxide for organism X to grow well. OR Plant Z gives out oxygen during photosynthesis which is taken in by Organism X for respiration.
11 (c)	Organism X releases clearer water which allows more light to pass through the sea water, so plant Z can photosynthesise more.
12 (a)	Q and U. When R decreases, U has no R to eat and U will decrease. Less R to feed on Q and Q will increase.
12 (b)	<pre> graph TD     B --&gt; E     E --&gt; A     C --&gt; A     C --&gt; E     C --&gt; D             </pre>
13 (a)	
13 (b)	When there are more/less raised strips, the time taken for the marble to reach the bottom of the ramp is longer/shorter. OR The amount/number of raised strips has no effect on the time taken for the marble to reach the bottom of the ramp.  Note: Both changed variable (the number of raised strips) and the measured variable must be mentioned in the hypothesis.

13 (c)	Shorter time. Same amount of (gravitational) potential energy of marble is converted to more kinetic energy and less heat energy due to less friction.
14 (a)	Gravitational force and magnetic force of attraction
14 (b)	No. Copper is non-magnetic and cannot be attracted to the magnet.
14 (c)	At a greater height, the magnetic force of attraction was less than the gravitational force acting on the paper clip.