

SINGAPORE CHINESE GIRLS' SCHOOL
PRIMARY 6 SCIENCE
Term 1 Weighted Assessment
Topics: Forms of Energy and its conversion

Term 1 WA

Name: _____ ()

Date: _____

Class: Primary 6 SY / C / G / SE / P

	Total Actual Marks	Total Possible Marks
Section A		26
Section B		14
Total		40

Section A (26 marks)

For each question from 1 to 13, four options are given. One of them is the correct answer. **Choose the correct answer and write its number in the Answer Sheet on Page 4.**

1. Which one of the following is NOT an example of energy conversion?

- (1) plant making food
- (2) cup of water at room temperature
- (3) turning on the television
- (4) ball bouncing up and down

2. Which of the following actions help to conserve electricity?

- A. Choose energy-efficient appliances.
- B. Use the air-conditioner instead of the fan.
- C. Use more petrol to generate electricity.
- D. Dry hair naturally instead of using the hair dryer.

- (1) A and D only
- (2) B and C only

- (3) B and D only
- (4) A, C and D only

3. Four balls, P, Q, R, S, of the same mass were placed on a stand at different heights.

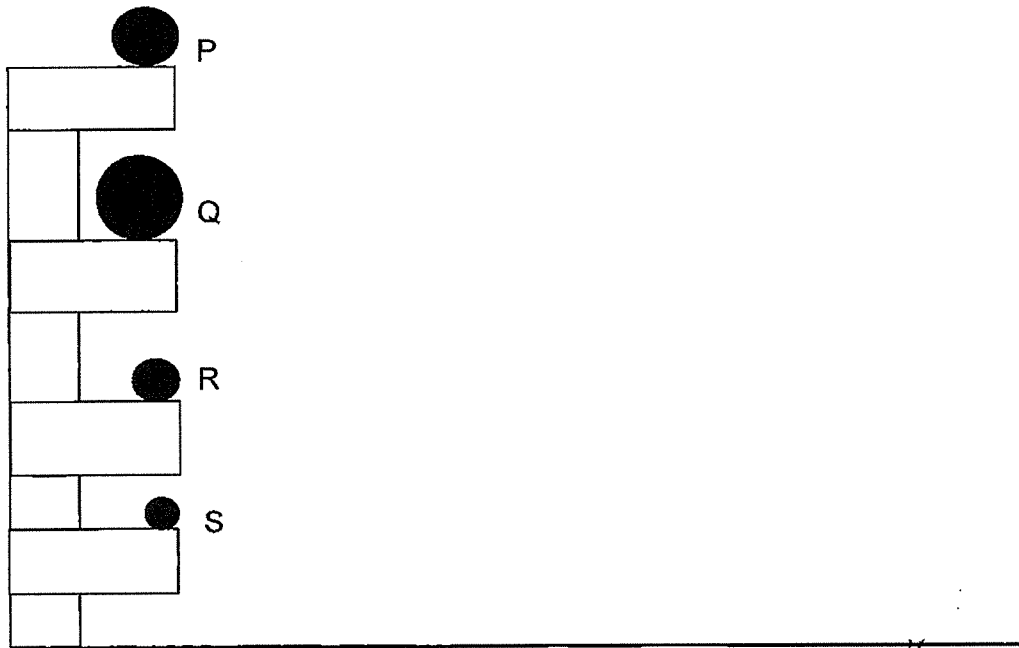

Arrange the balls from the one with the least to the one with the greatest gravitational potential energy.

- (1) S, R, Q, P
 (2) S, R, P, Q
 (3) Q, P, R, S
 (4) P, Q, R, S
4. Four hot air balloons, A, B, C and D were used with varied conditions as stated in the table below.

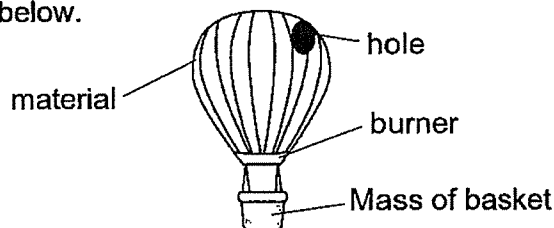

Hot air balloon	Conditions			
	Material	Has a hole	Fire at burner	Mass
A	X		✓	✓
B	Y	✓	✓	✓
C	X		✓	✓
D	Y	✓		✓

Based on the table above, Caryn was able to find out if _____ affects the time taken for the hot air balloon to rise up in the air.

- (1) material
 (2) fire at burner
 (3) area of hole
 (4) mass

5. Two similar balls 1 and 2 are released from the side of a container as shown in the diagram below. Position W and Y are of the same height above the ground.

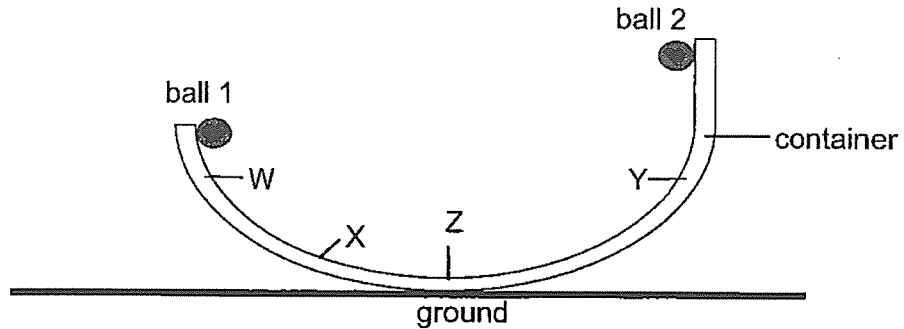

Which of the following statement/s is/are correct about the two balls after they are released and before they reach point Z?

- A : Ball 1 has less kinetic energy than ball 2 at point Z.
 B : Ball 2 at point Y has the same amount of kinetic energy with ball 1 at point W.
 C : Ball 2 at point Y has more potential energy than Ball 1 at point X.

- (1) B only
 (2) A and C only
 (3) B and C only
 (4) A, B and C

6. The wind turbine is used to generate electricity for bulbs in the homes.

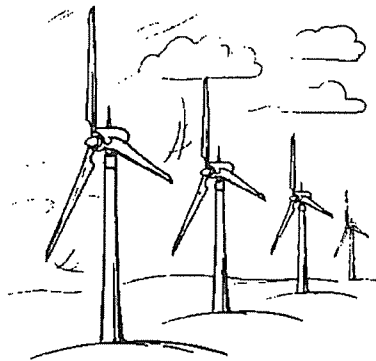

Which of the following correctly shows the main forms of energy in the wind and the wind turbine and the energy changes in the bulbs?

	Wind	Wind turbine	bulbs
(1)	potential	potential	light → electrical
(2)	potential	kinetic	light → light
(3)	kinetic	potential	light → light
(4)	kinetic	kinetic	electrical → light

7. Ramesh played the basketball and observed the height of the ball when it bounces back each time it hits the ground.

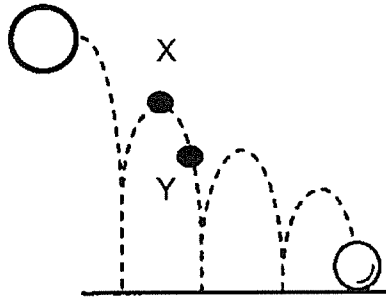

Compare the potential and kinetic energy of the ball at Point X and Point Y. Which of the following is correct?

	Potential energy at Point Y compared to Point X	Kinetic energy at Point Y compared to Point X
(1)	less	less
(2)	more	more
(3)	more	less
(4)	less	more

8. The diagram below shows a waterfall.

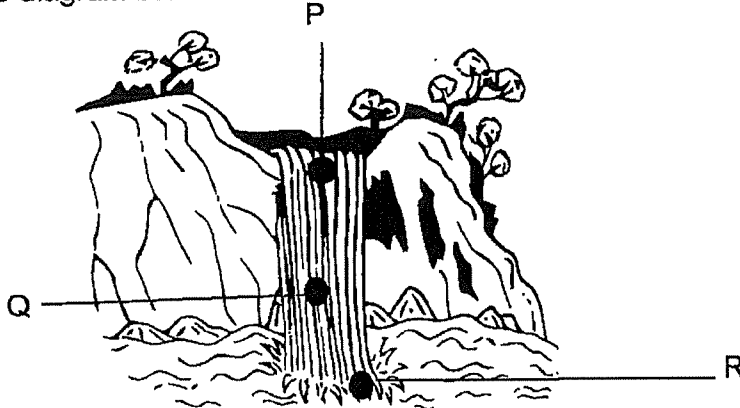

Which one of the following best describes the form(s) of energy of the water at P, Q and R respectively?

	P	Q	R
(1)	potential energy	kinetic energy	sound energy
(2)	potential energy	potential energy	kinetic energy
(3)	potential energy and kinetic energy	kinetic energy and sound energy	potential energy and heat energy
(4)	potential energy and kinetic energy	potential energy, kinetic energy and sound energy	kinetic energy and sound energy

9. The diagram below shows a circuit used in an alarm system. A bell and a light bulb are connected to the circuit.

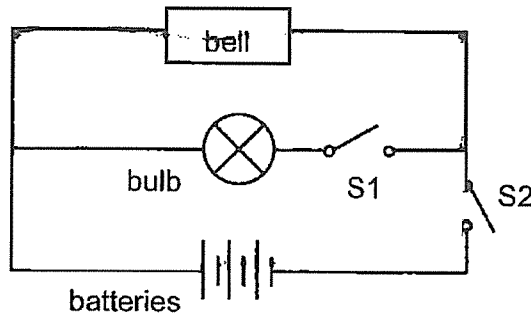

Which one of the following shows the correct energy conversions when switch S1 is opened and switch S2 is closed?

- (1) electrical energy \rightarrow light energy
 - (2) electrical energy \rightarrow light energy + sound energy
 - (3) potential energy \rightarrow electrical energy \rightarrow sound energy
 - (4) potential energy \rightarrow electrical energy \rightarrow light energy + sound energy
10. An experiment was set up to find out how the mass of the toy car and height of the ramp affects the distance moved by the car along the floor.

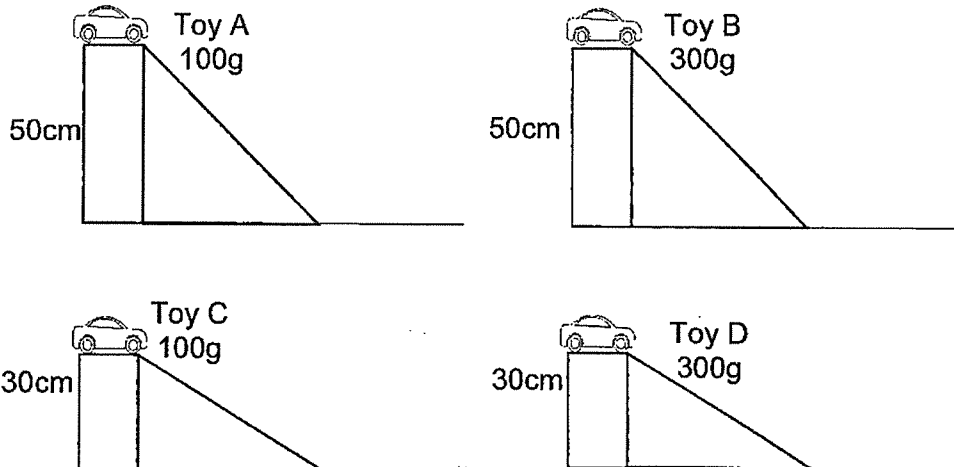

Arrange the toy cars according to the distance moved, from the shortest to the furthest distance.

	Shortest distance	—————→			Furthest distance
(1)	A	B	C	D	
(2)	B	C	D	A	
(3)	D	A	B	C	
(4)	C	D	A	B	

11. A ball which is tied to a string swings from A to B and then to C as shown below.

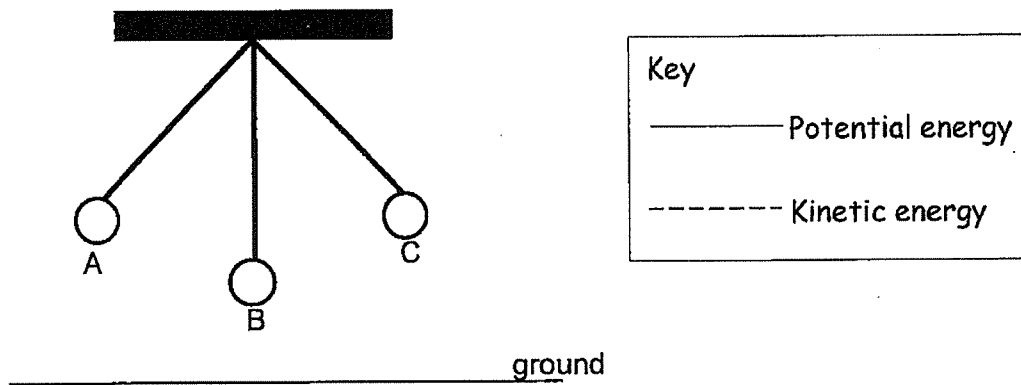

Which of the graphs illustrates the change in the amount of kinetic and potential energy of the ball from A to C?

(1) Amount of Energy

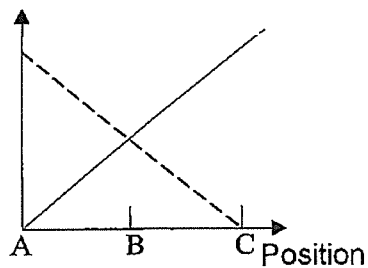

(3) Amount of Energy

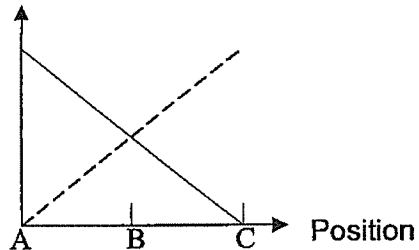

(2) Amount of Energy

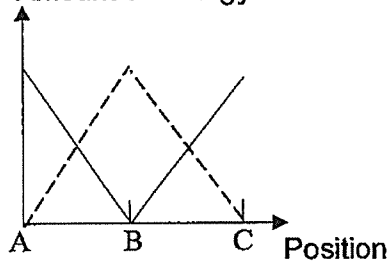

(4) Amount of Energy

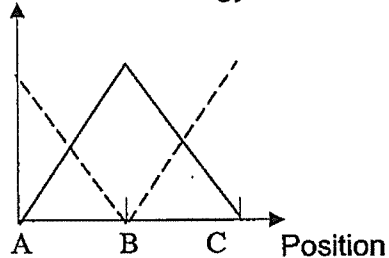

12. Xin Yu set up an experiment using a toy car.

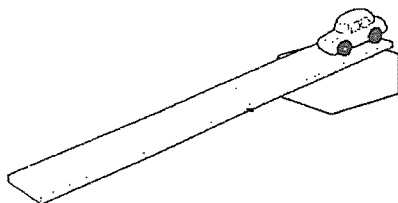

What will happen to the kinetic and potential energy of the car as it moves down the slope?

	Kinetic energy	Potential energy
(1)	remains unchanged	increases
(2)	remains unchanged	decreases
(3)	increases	decreases
(4)	decreases	decreases

13. Two balls, X and Y, of same size and mass, were released from the top of the ramps A and B at the same time. They rolled downwards and collided with each other.

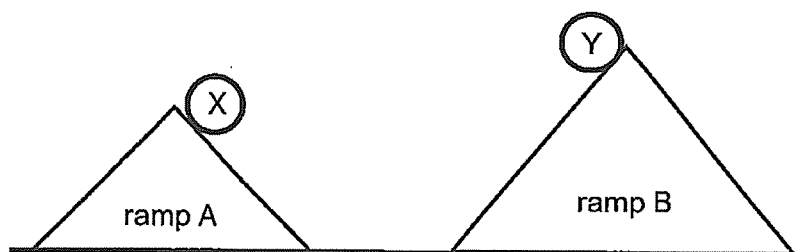

Which of the following observation/s is/are correct?

- A : Both balls moved slower as they reached the bottom of the ramps.
- B : Ball X had less gravitational potential energy than Ball Y at the point of release.
- C : Both balls had the same gravitational potential energy at the point of release.
- D : Ball X had less kinetic energy than Ball Y just before they hit each other.

- (1) A and B only
- (2) A and C only
- (3) B and D only
- (4) C and D only

SINGAPORE CHINESE GIRLS' SCHOOL
PRIMARY 5 SCIENCE
Term 1 Weighted Assessment
Topics: Forms of Energy and its conversion

Term 1 WA

Name: _____ ()

Class: Primary 6 SY / C / G / SE / P

Answer Sheet for Section A

- | | | |
|--------|---------|---------|
| 1. () | 6. () | 11. () |
| 2. () | 7. () | 12. () |
| 3. () | 8. () | 13. () |
| 4. () | 9. () | |
| 5. () | 10. () | |

Section B (14 marks)

For Questions 14 to 17, write your answers in the space provided.

14. When the rubber band of the slingshot was stretched, the pebble was shot forward and travelled a distance.

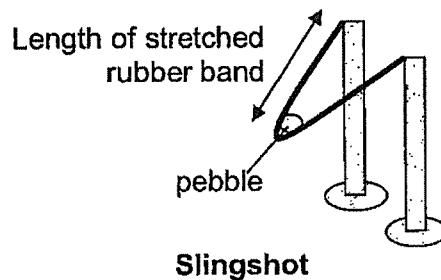

The table below shows the distance travelled by the pebble when the slingshot was stretched.

Length of stretched rubber band (cm)	Distance travelled by pebble (cm)
5	100
10	150
20	250

- (a) Which object is the source of energy that enables the pebble to move? [1]

(b) State the relationship between the distance travelled by the pebble and the length of stretched rubber band. [1]

(c) Suggest what Lina should do to increase the reliability of the results. [1]

(d) Will the distance travelled by the pebble be longer or shorter when Lina adds an additional rubber band? Explain your answer. [2]

15. Study the electrical system below. When the switch is closed, the nichrome wire becomes hot and soon, the piece of paper moved.

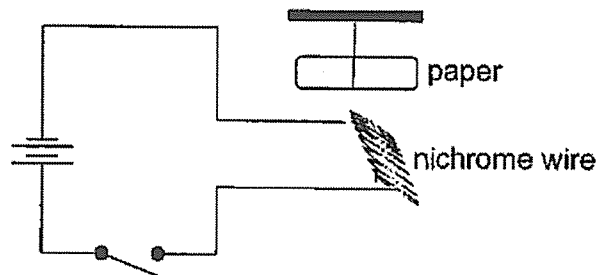

Explain, using forms of energy, why the piece of paper moved when the switch is closed. [2]

16. Danny was balancing on his skateboard at the edge of the ramp before he moved down. He took off into the air when he reached the end of the ramp at C.

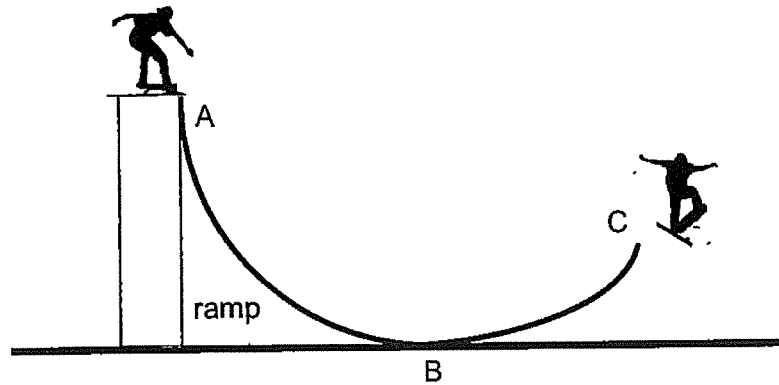

- (a) Fill in the boxes to show the energy changes of the skater from point A to point C. [2]

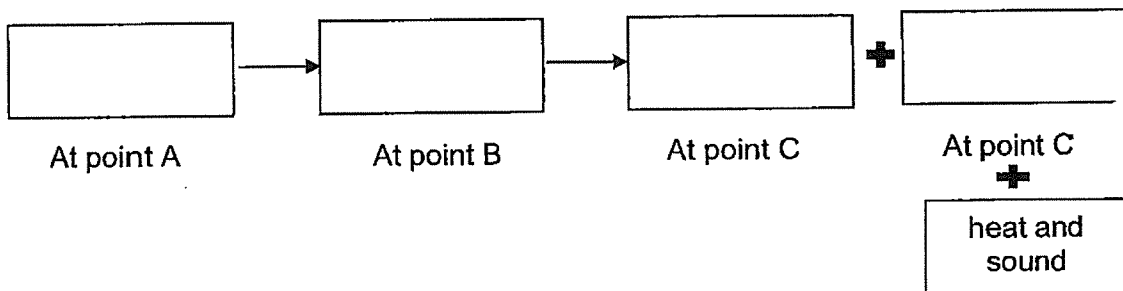

Danny used another ramp to skate.

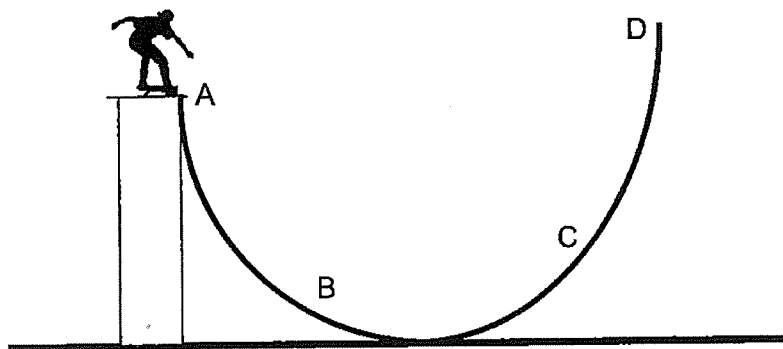

- (b) Was Danny able to reach Point D? Explain your answer in terms of energy conversion. [1]

- (a) At which point, A, B, C or D, did Danny have the most kinetic energy? [1]

Point _____

17. Leanne set up an experiment using some identical strings and four balls of different masses as shown below. When the strings were released, the balls dropped and created dents in the tray of sand.

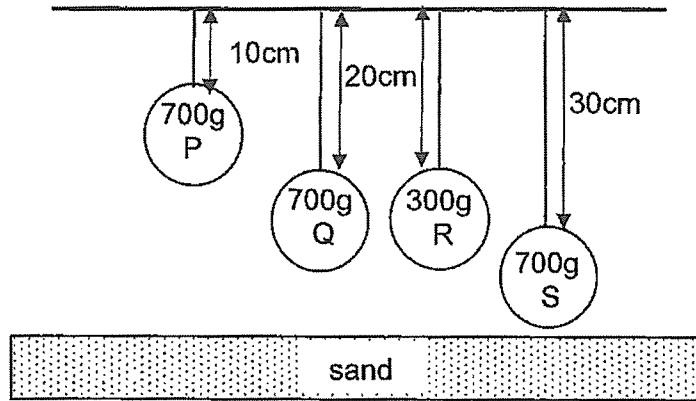

- (a) Fill in the boxes below to show the main energy conversion of the ball when the string was cut. [1]

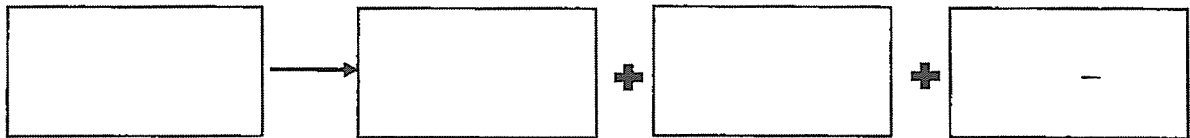

- (b) Which ball would produce the deepest dent after hitting the sand? _____ [1]

- (c) Leanne wanted to find out how the height from which the ball was dropped would affect the depth of the dent. Which balls should she use for a fair test? [1]

Balls _____ and _____

End of paper

SCHOOL : SCGS PRIMARY SCHOOL

LEVEL : PRIMARY 6

SUBJECT : SCIENCE

TERM : WA1 2023

Q 1	Q2	Q3	Q4	Q5	Q6	Q7	Q8	Q9	Q10
2	1	1	2	2	4	4	4	3	4

Q 11	Q12	Q13
2	3	3

Q14)	<p>a) The stretched rubber band.</p> <p>b) As the length of the stretched rubber band increases, the distance travelled by the pebble increases.</p> <p>c) Each time the distance of the rubber band was stretched longer, she should test the length many times and find the average.</p> <p>d) It would be longer by adding one more rubber band, if would increase the amount of potential energy that would be converted into more kinetic energy, when it is released than when it has only one rubber band.</p>
Q15)	<p>The electrical energy in the wire was converted into heat energy in the wire. Heat energy in the wire makes the air around it expand. Kinetic energy in the air makes the paper move.</p>
Q16)	<p>a)Gravitational potential energy → Kinetic energy → kinetic energy + potential energy</p>

	<p>b)No. Point D is higher than A. Danny has not enough potential energy to be converted into enough kinetic energy for him to go higher than A</p> <p>c)B</p>
Q17)	<p>a)Potential energy → kinetic energy + heat energy + sound energy</p> <p>b)P</p> <p>c)P and S</p>