

**RAFFLES GIRLS' PRIMARY SCHOOL
WEIGHTED ASSESSMENT 1
PRIMARY SIX
2023**

SCIENCE

Name: _____ ()

Date : 21 February 2023

Class: P6 _____

Total Time: 50min

INSTRUCTIONS

1. Write your name, class and index number in the spaces provided above.
2. Do not turn over this page until you are told to do so.
3. Follow all instructions carefully.
4. Answer all questions.
5. For questions 1 to 8, write your answers clearly in the spaces provided.
6. The number of marks is shown in brackets [] at the end of each question or part question.

Your score out of 30	
Parent's signature	

1. The diagrams show the direction of blood flow in some parts of the human and fish bodies.

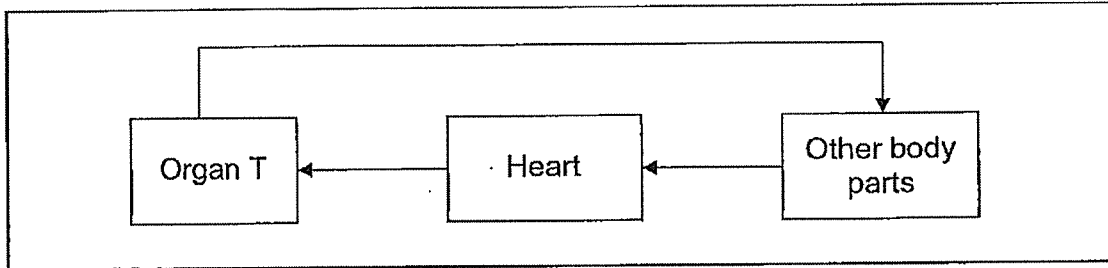

Circulatory system of a fish

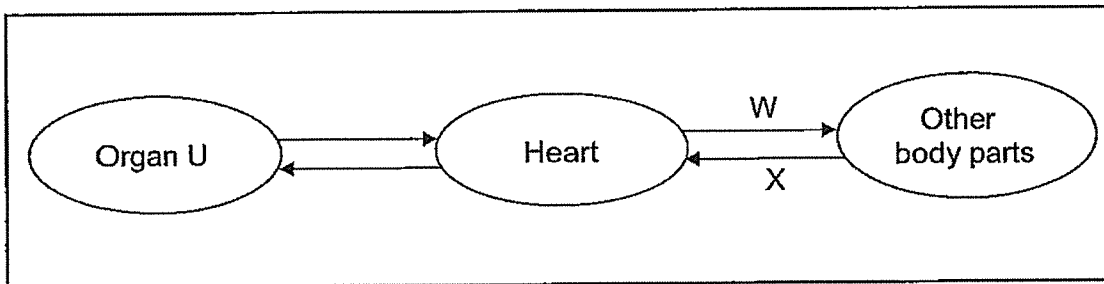

Circulatory system of a human

Based on the diagrams, answer the following questions.

- (a) Identify organs T and U. [2]

Organ T: _____

Organ U: _____

- (b) Name one substance in the blood where its amount is higher in W than X. [1]

Score	3
-------	---

2. Ahmad prepared two set-ups, Y and Z, as shown in the diagram. He used two similar pots of plants watered with same amount of water. He put one pot of plant in a clear jar while the other pot of plant in an opaque jar. He placed them in the open field from 7a.m to 12a.m.

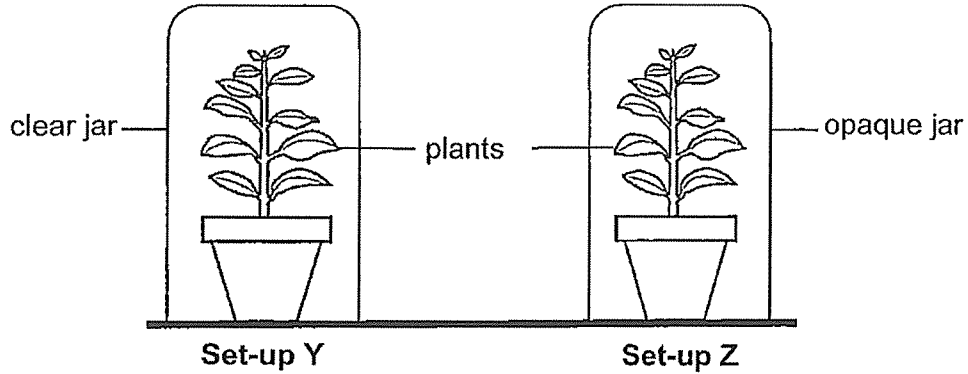

- (a) The graph shows the change in the amount of gases in **set-up Y** during the experiment. Label the gases in the boxes provided. [2]

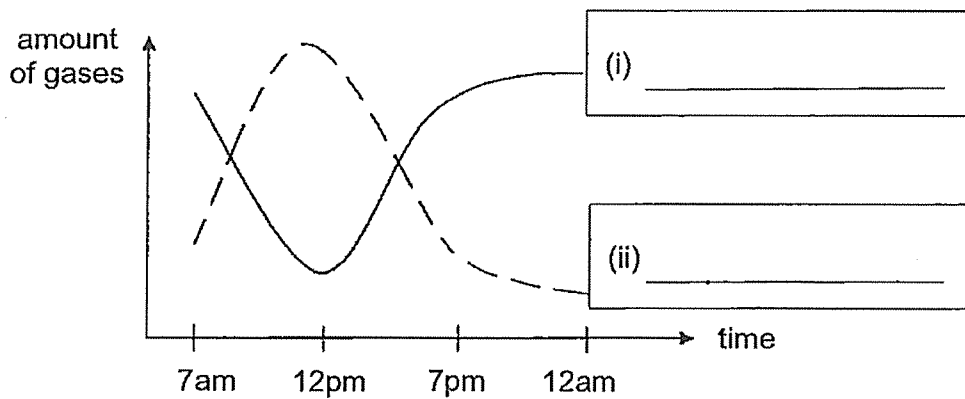

- (b) How would the amount of oxygen in **set-up Z** change from the start to the end of the experiment? Explain your answer. [2]

Score	4
-------	---

3. Betty prepared set-ups A and B as shown to find out if the amount of carbon dioxide affects the rate of photosynthesis.

When baking soda was mixed in water, it released carbon dioxide.

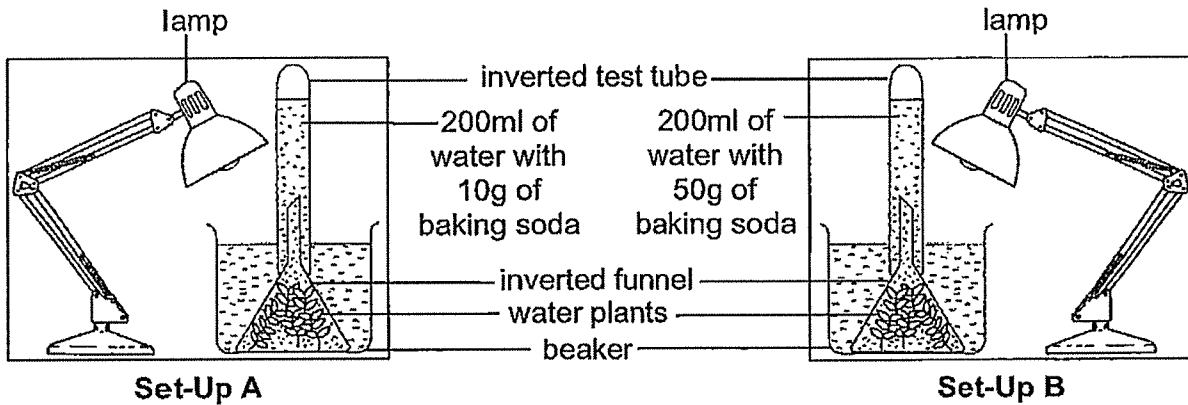

- (a) What result should she collect to measure the rate of photosynthesis? [1]

- (b) State two variables that must be kept the same to ensure a fair test. [2]

(i) _____

(ii) _____

Continue on page 4

Score	3
-------	---

Continued from page 3

- (c) Based on the results she obtained, she plotted the graphs as shown. Label the graphs, **set-up A** and **set-up B**, to show which one represents the results for set-up A and set-up B. [1]

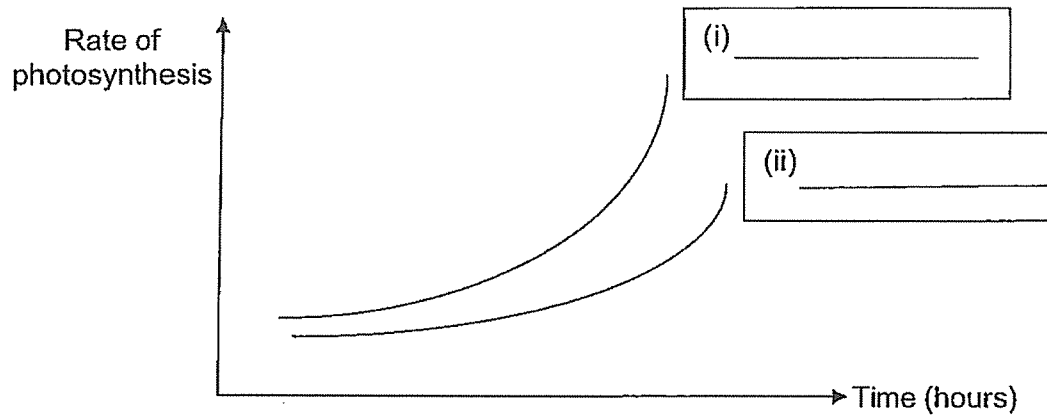

Her teacher told her that her experiment could be further improved by adding a control set-up as shown in the diagram.

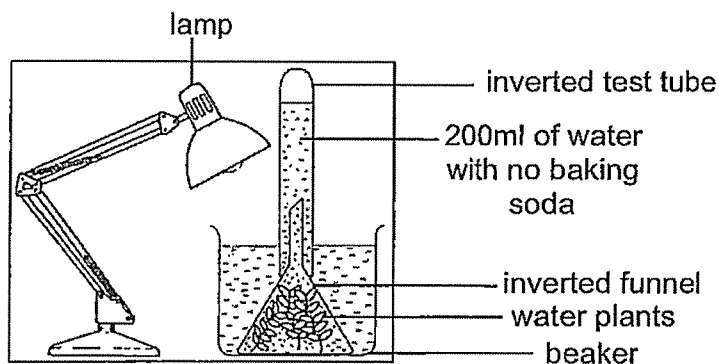

Control set-up

- (d) State the purpose of the control set-up. [1]

Score	1 / 2
-------	-------

4. Bala heated some water at 20°C. At the tenth minute, the water started to boil.

(a) State what boiling means. [1]

(b) In the diagram, draw the graph to show the change in temperature of water over twelve minutes. [1]

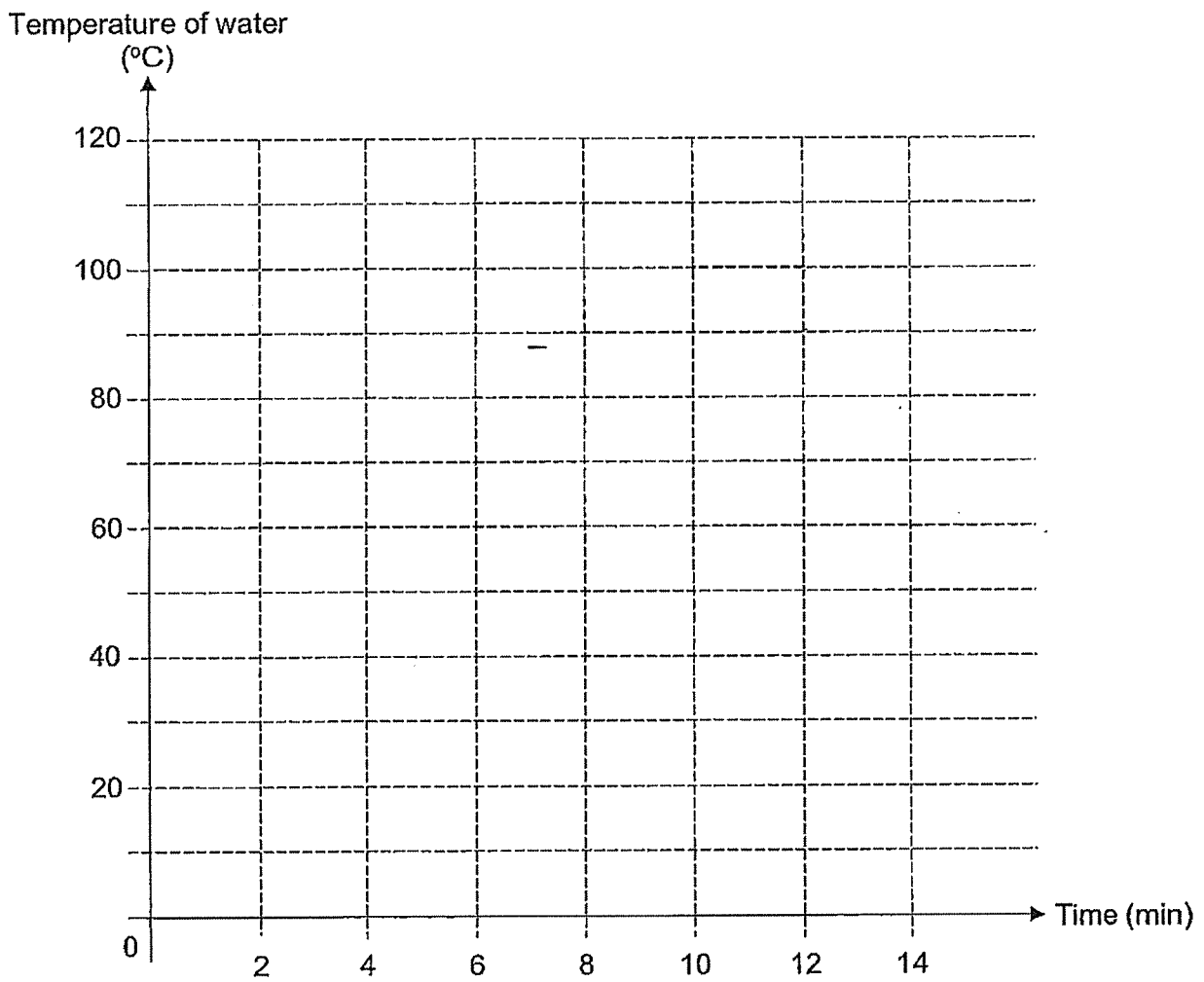

(c) State the change in state of water at the tenth minute. [1]

Score	3
-------	---

5. The diagram shows a device that is used to collect clear water from muddy water.

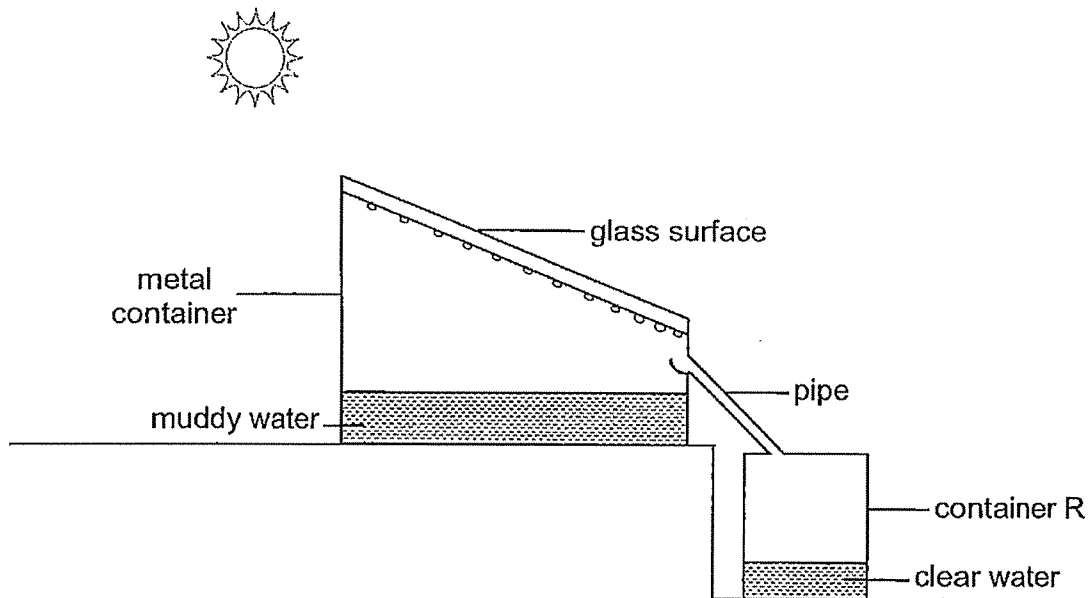

- (a) Based on the diagram, explain how clear water in container R is obtained.

[2]

Continue on page 7

Score	2
-------	---

Continued from page 6

The graph shows the volume of water collected in container R in a day based on the daily average temperature.

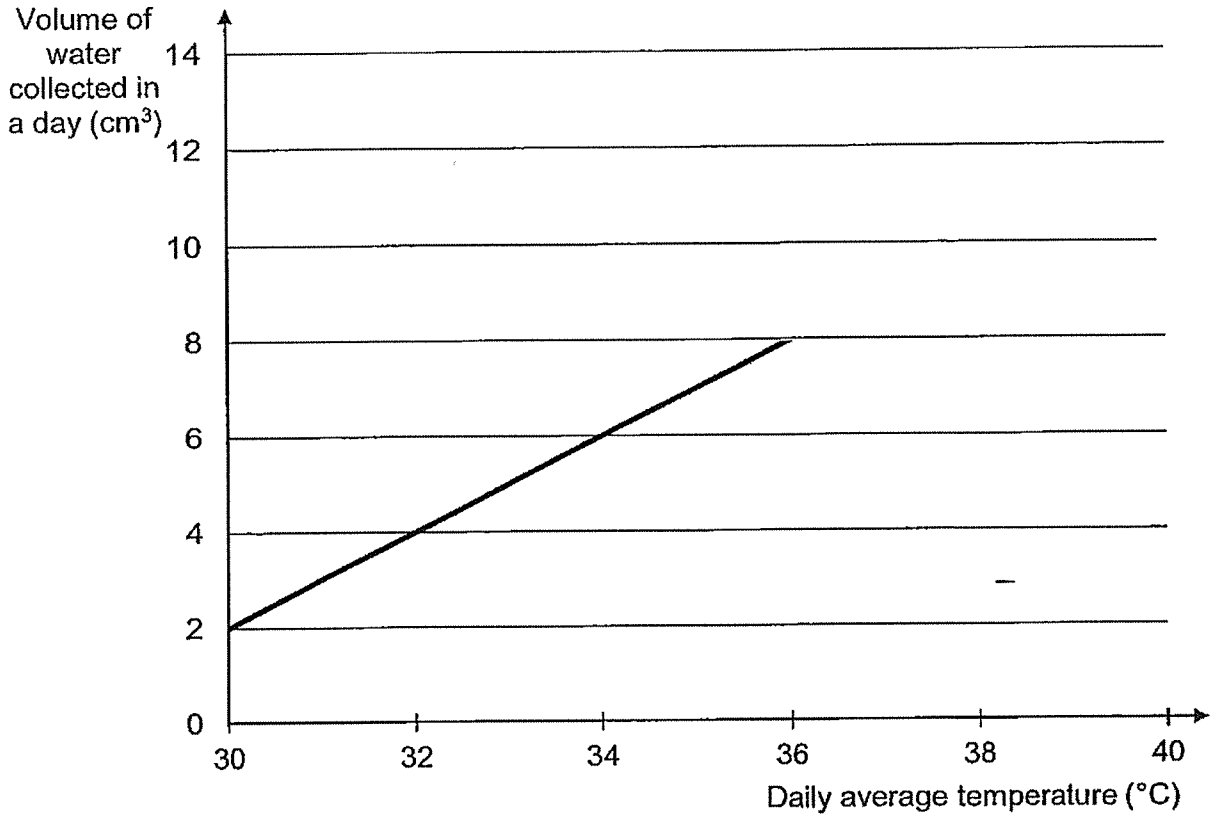

- (b) Based on the graph, predict the amount of water collected when the daily average temperature is 40°C. [1]

- (c) State the relationship between the daily average temperature and the volume of water collected in a day. [1]

Score	2
-------	---

6. The diagram shows a circuit. All the bulbs and batteries used in the circuit are in working condition. When the iron rod is resting on point K, bulb S lights up as shown in diagram C.

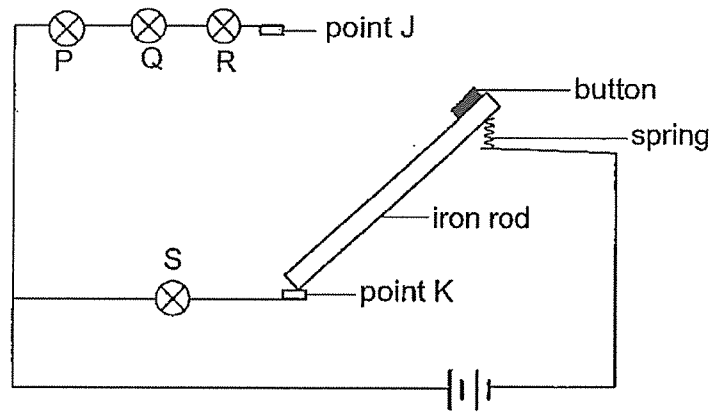

Diagram C

Once the button is pressed, the rod moves up and comes into contact with point J and bulbs P, Q and R will light up as shown in diagram D.

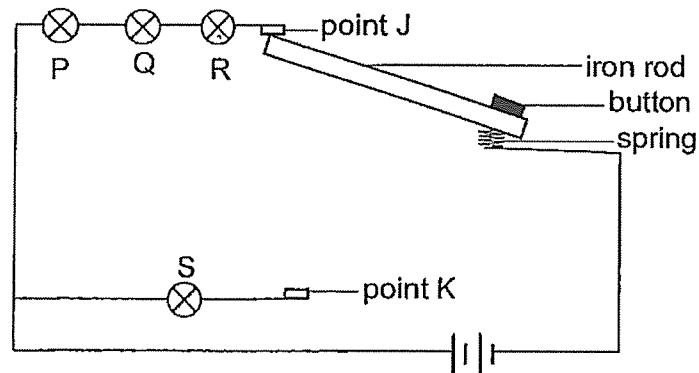

Diagram D

- (a) Which bulb(s) in diagram D will not light up when bulb P fuses? [1]

- (b) Describe what happened when the iron rod is replaced with a plastic rod in diagram D. Explain your answer clearly. [2]

Continue on page 9

Score	3
-------	---

Continued from page 8

- (c) Bulb S in diagram C lit up more brightly than bulbs P, Q, and R in diagram D. Complete the circuit diagram by drawing bulbs P, Q and R, so that they will have the same brightness as bulb S in diagram C. [1]

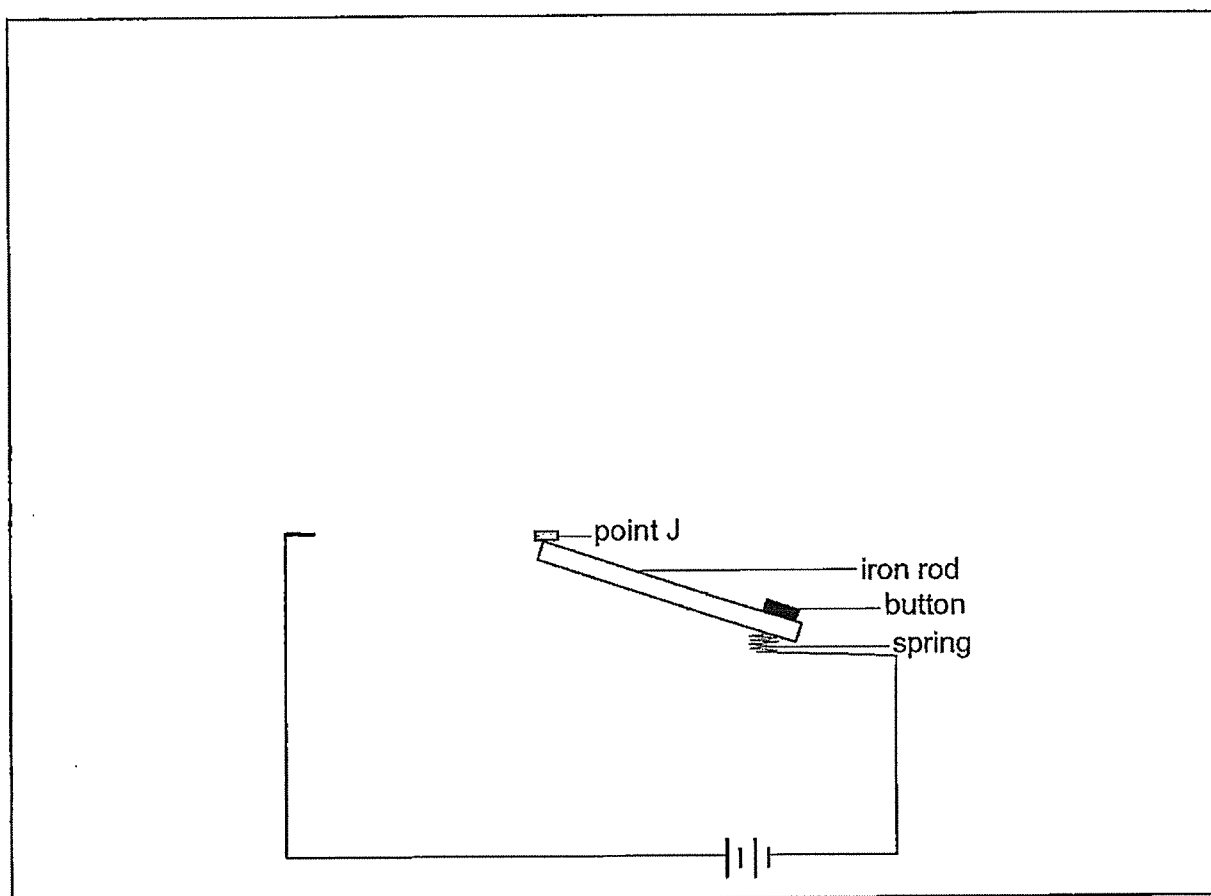

Score	1
-------	---

7. Tim set up an experiment as shown to find out how the number of stands of the container affects the temperature of water in it.

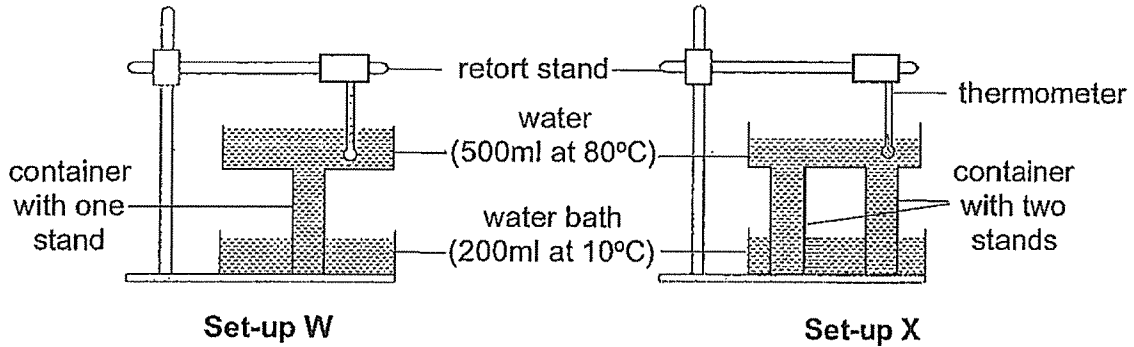

The graph shows the temperature change of water in the container.

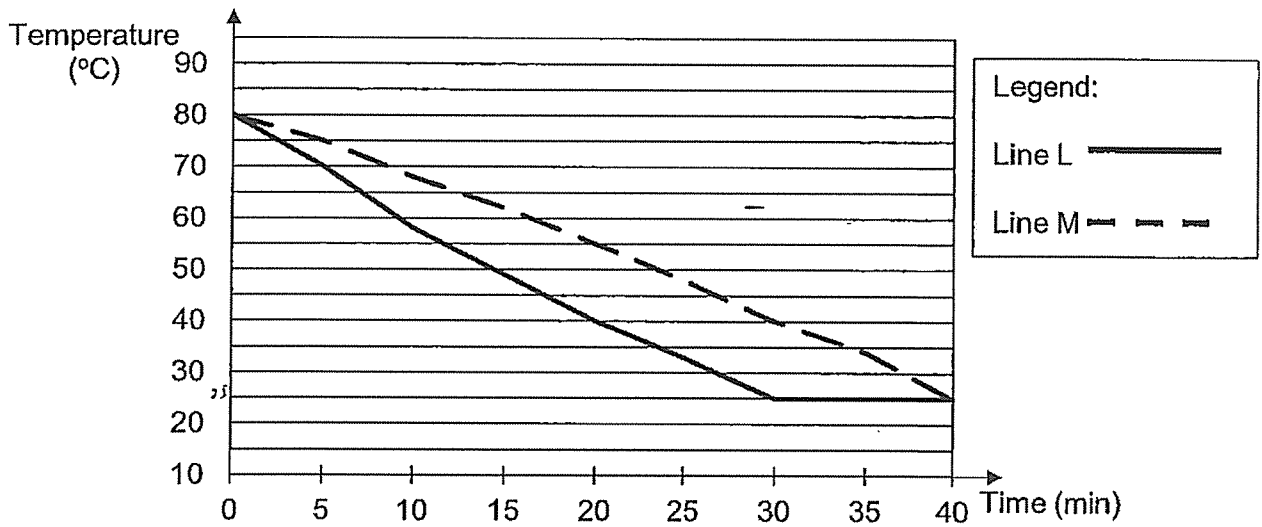

- (a) Based on the graph, state the room temperature. [1]

- (b) Which line, L or M, represents the temperature change of water in set-up X? Explain your answer. [2]

Score	3
-------	---

8. Three identical sized cups, E, F and G, made of different materials were each filled with 250ml of cold water. The table shows the change in temperature of the cold water in each cup over a period of twenty minutes.

Time (min)	Temperature of water in cup (°C)		
	Cup E	Cup F	Cup G
0	5	5	5
5	12	8	9
10	17	11	13
15	22	15	18
20	28	22	25

- (a) State what temperature means. [1]

- (b) Based on the data, arrange the cups, E, F and G, in order of their heat conductivity, starting from the best conductor of heat. [1]

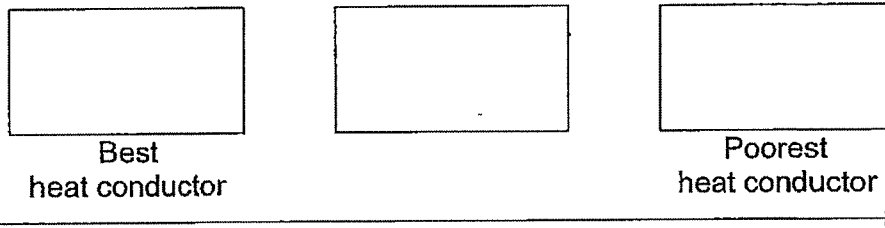

- (c) After two hours, all the cups were at the same temperature. Which one of the cups would feel the coldest to touch? Explain your answer. [2]

End of Paper

Score	4
-------	---

SCHOOL : RAFFLES GIRL'S PRIMARY SCHOOL

LEVEL : PRIMARY 6

SUBJECT : SCIENCE

TERM : WA1 2023

Q1)	a) Organ T: Gills Organ U: Lungs b) oxygen c)
Q2)	a)i) carbon dioxide ii) oxygen b) It will decrease sunlight amount reach the jar as it is opaque. Plant cannot photosynthesis to reduce oxygen. It repress so it take in oxygen decreasing its amount in the set-P
Q3)	a) Number of oxygen bubbles. b) i) The intensity of light from the lamps. ii) Type of water plants. c)i) Set-up B ii) Set-up A c) To compare and confirm that the only difference in the number of oxygen bubbles is because of the baking soda added to the water.
Q4)	a) Boiling is a process when a liquid grains heat until it reaches boiling point and changes state to a gaseous state.

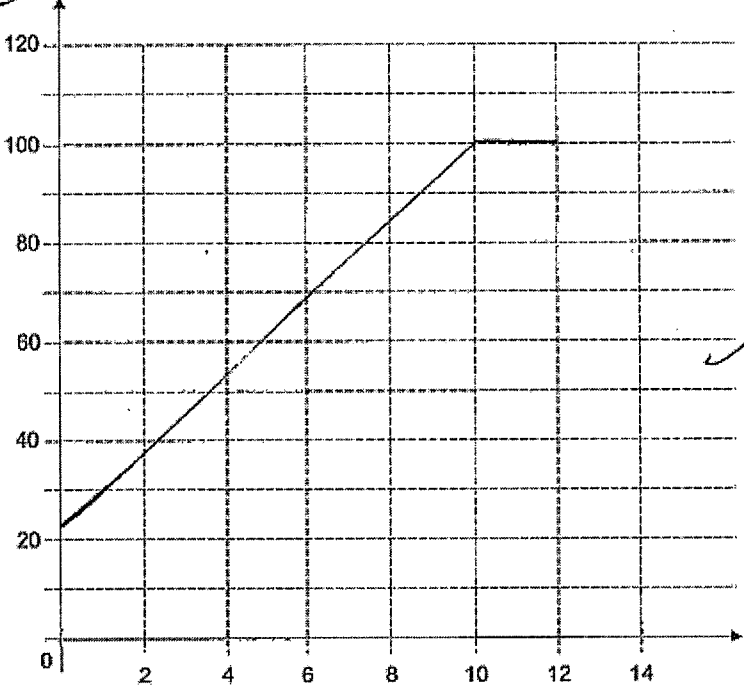
	<p>b)</p> <p>Temperature of water (°C)</p>  <p>b) It changed from liquid to gas.</p>
<p>Q5)</p>	<p>a) Pure water in the muddy water gained heat from the sun and evaporated to form water vapour. The warmer water vapour came into contact with the cooler inner glass surface, lost heat and condensed to form water droplets, The water droplets slid down the glass surface through the pipe then into container R.</p> <p>b) 12cm³</p> <p>c) As the daily average temperature increases, the volume of water collected in a day also increases.</p>
<p>Q6)</p>	<p>a) Bulbs Q and R</p> <p>b) None of the bulbs would light up. Plastic is an insulator of electricity. It would be an open circuit and electric current could not flow through the circuit. Thus, none of the bulbs would light up.</p>

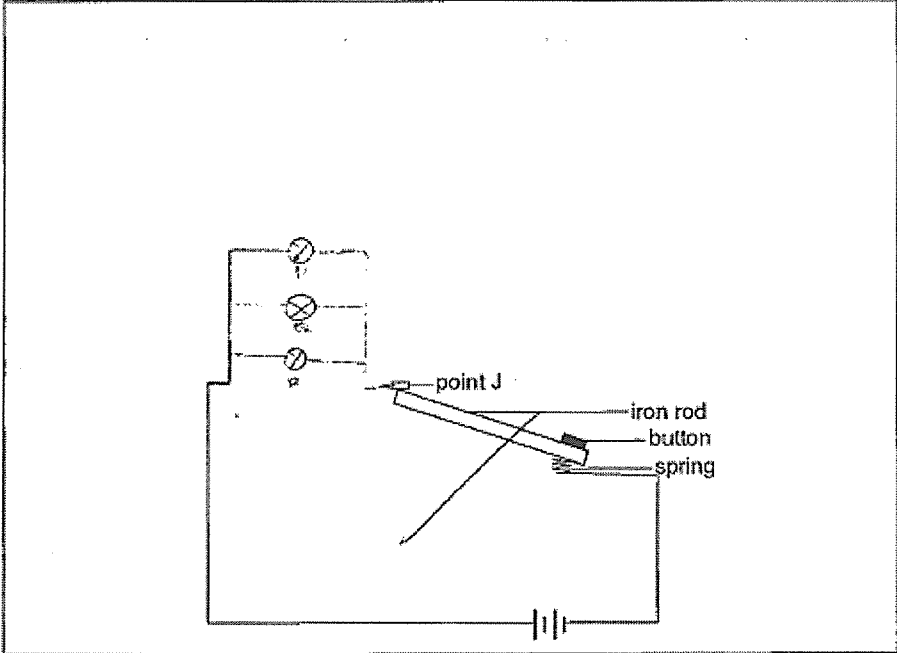
	<p>c)</p> 
<p>Q7)</p>	<p>a) 25°C</p> <p>b) L. Line L shows a faster change in temperature. The container in set has two stands and a greater surface area in contact with the water bath. The water in the container loses heat to the water bath faster.</p>
<p>Q8)</p>	<p>a) Temperature is the measurement of how hot or how cold something is.</p> <p>b) Cup E / Cup G / Cup F</p> <p>c) Cup E. Temperature of water in Cup E increases the faster. It is the best heat conductor Cup E gains heat from the hand the faster.</p>

