

Name : _____ () Index No.

--	--	--	--	--	--	--	--	--	--

Class : Primary 6 SY / C / G / SE / P

24 August 2023



SINGAPORE CHINESE GIRLS' SCHOOL
SECOND SEMESTRAL ASSESSMENT 2023

PRIMARY 6

SCIENCE

BOOKLET A

Additional Materials: Optical Answer Sheet (OAS)

Total Time for Booklets A and B: 1 h 45 min

INSTRUCTIONS TO CANDIDATES

1. Do not turn over this page until you are told to do so.
2. Follow all instructions carefully.
3. Answer all questions.
4. Use a 2B pencil to shade your answers on the Optical Answer Sheet (OAS).

Booklet A (56 marks)

For each question from 1 to 28, four options are given. One of them is the correct answer. Make your choice (1, 2, 3 or 4) and shade your answer on the Optical Answer Sheet.

1. Study the flowchart.

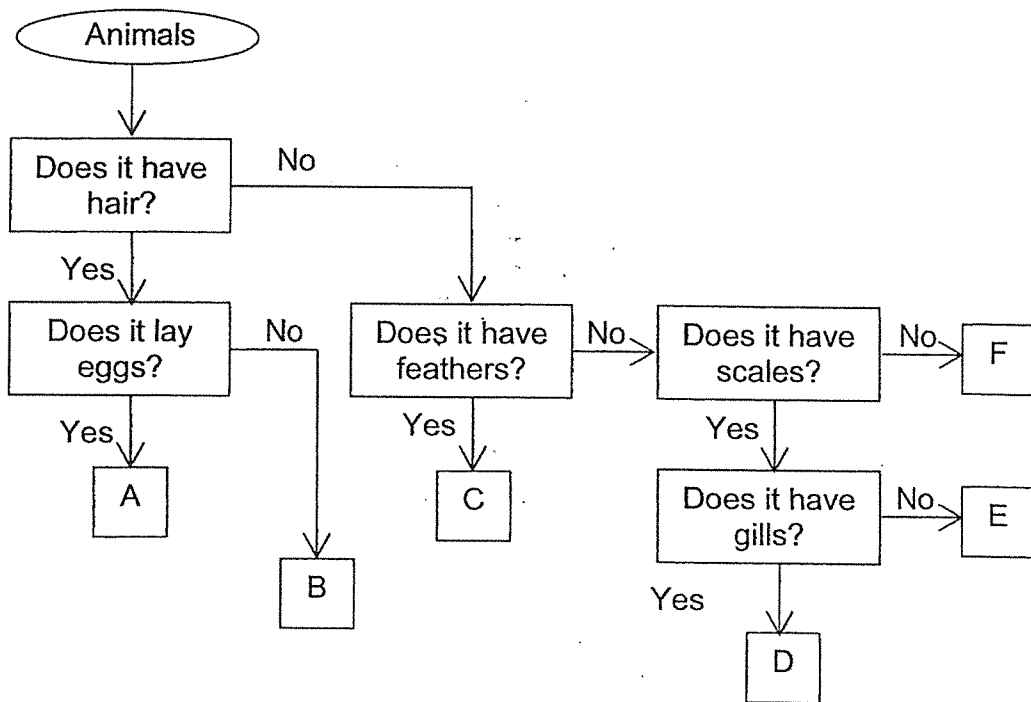

Based on the flowchart above, which of the following correctly matches the animal groups listed below?

	Mammal	Reptile	Amphibian	Fish
(1)	B	E	F	D
(2)	A	C	D	D
(3)	A	D	C	F
(4)	C	E	F	E

2. The table below shows the relationship among five organisms in a community.

L feeds on N.
 N feeds on O and M.
 K provides food for M and O.

Which one of the following classifies the roles of the organisms in the community correctly?

	Producer	Prey only	Predator and Prey	Predator only
(1)	KV	M	N and O	L
(2)	O	K and M	N	M
(3)	M	K	L	N and O
(4)	K	M and O	N	L

3. Which of the following substances is **not** transported by the human circulatory system?
- (1) water
 - (2) digested food
 - (3) carbon dioxide
 - (4) undigested food

4. Claire placed a healthy potted plant in a sealed glass container as shown below.

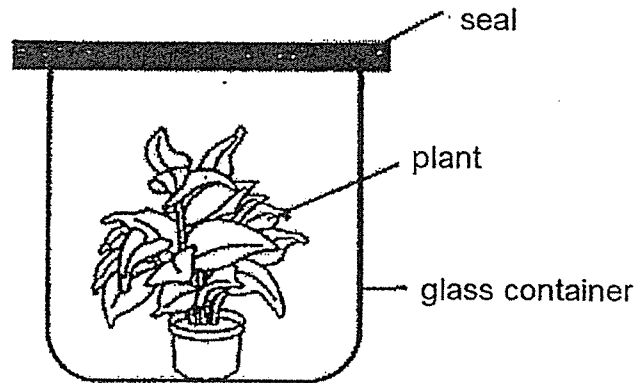

She placed it in the garden and recorded the amount of carbon dioxide in the container at regular intervals over 24 hours. Her results are plotted in the graph below.

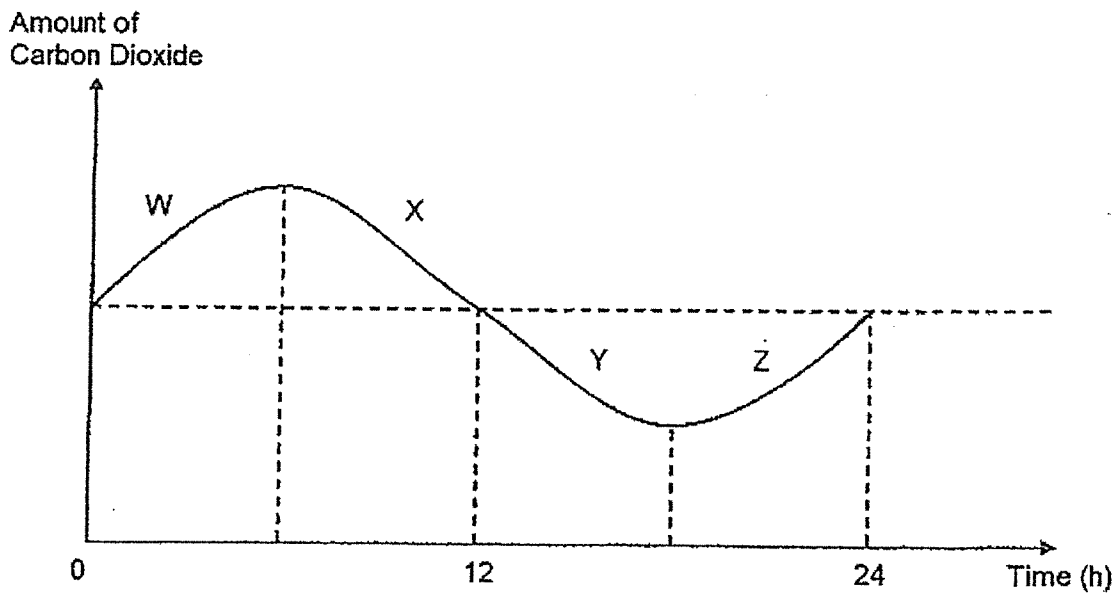

Which parts of the graph show photosynthesis and respiration taking place?

	Photosynthesis	Respiration
(1)	W and X	W and Z
(2)	X and Y ✓	W, X, Y and Z
(3)	W and Z	X and Y
(4)	Y and Z	W, X, Y and Z

5. Jessica studied the human body system as shown below. The arrows represent the flow of blood.

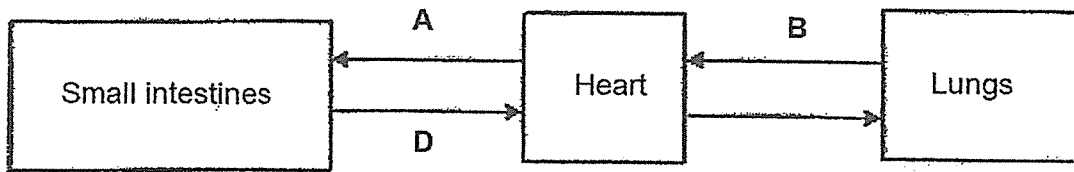

Which arrow represents blood richest in digested food?

- (1) A
 - (2) B
 - (3) C
 - (4) D
6. Study the diagram below.

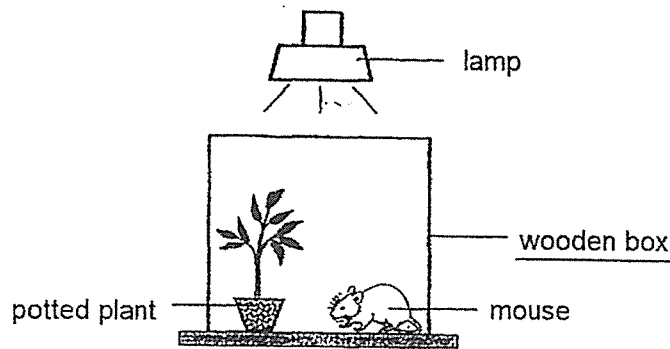

Which of the following graphs shows the most likely changes in the amount of gases in the container over 3 hours?

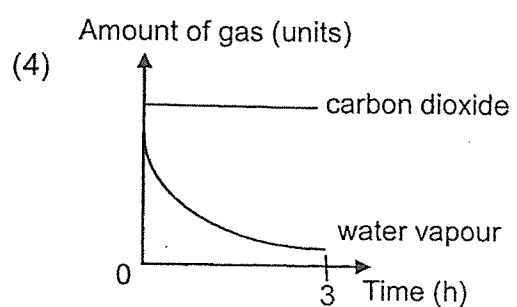
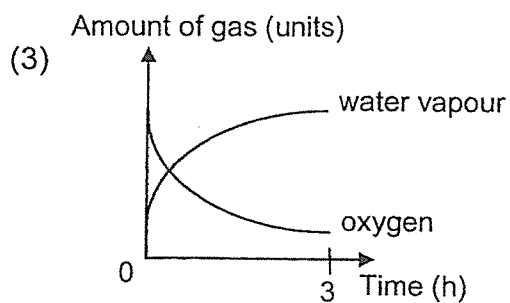
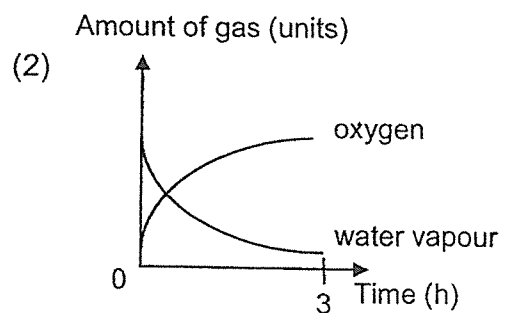
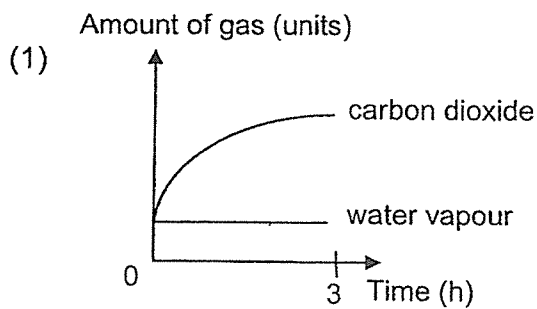

7. The diagrams below show the plant and human reproductive systems.

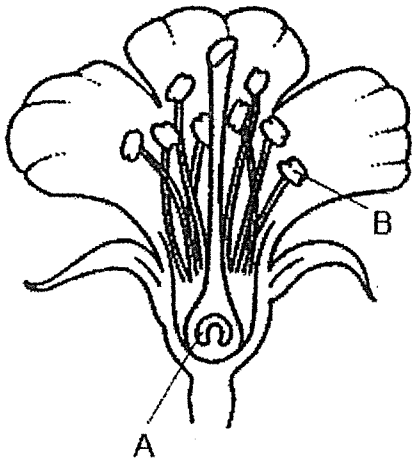

Reproductive system of flowering plants

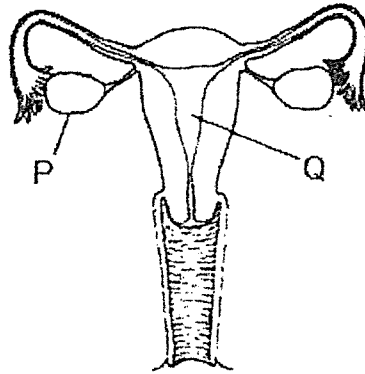

Female Human reproductive system

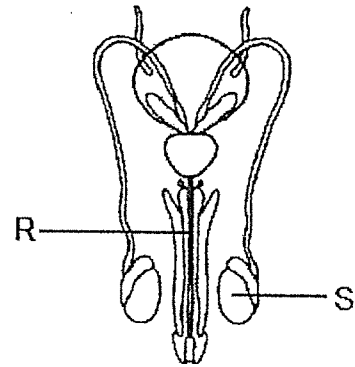

Male Human reproductive system

Which parts of the human reproductive system have the same functions as parts A and B?

	Part A	Part B
(1)	Q	S
(2)	R	P
(3)	P	S
(4)	S	P

8. The table below shows the different ways plants and animals obtain their food.

	Plants	Animals
A	Use the sun's energy to make food	Depend on the sun's energy indirectly for food
B	Use oxygen and water to make food	Need oxygen to survive and hunt for food
C	Need carbon dioxide to make food	Need carbon dioxide to digest food
D	Food is transported throughout the entire plant through the food-carrying tubes	Food is transported throughout the entire body through the digestive system

Which differences are correct?

- (1) A only
- (2) B and D only
- (3) A, C and D only
- (4) All of the above

9. The picture below shows the cross-section of a fruit.

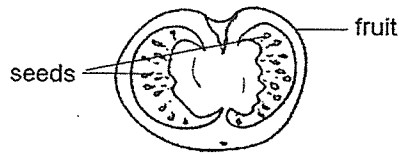

Based on the picture, which of the following statements is true about the flower from which this fruit has developed from?

- (1) The flower is fragrant.
- (2) The flower has large petals.
- (3) The flower has many ovules.
- (4) The flower grows in a cluster.

10. Which of the following statements is/are correct about the life cycles of the butterfly and the grasshopper?

- A : Both have a four-stage life cycle.
- B : Both spend their entire life cycle on land.
- C : Both the young of the butterfly and grasshopper resemble the adult.

- (1) B only
- (2) A and B only
- (3) A and C only
- (4) A, B and C

11. The diagram below shows the interaction among three groups of organisms. The dotted arrows in the food web show how carbon dioxide is added to or removed from the organisms.

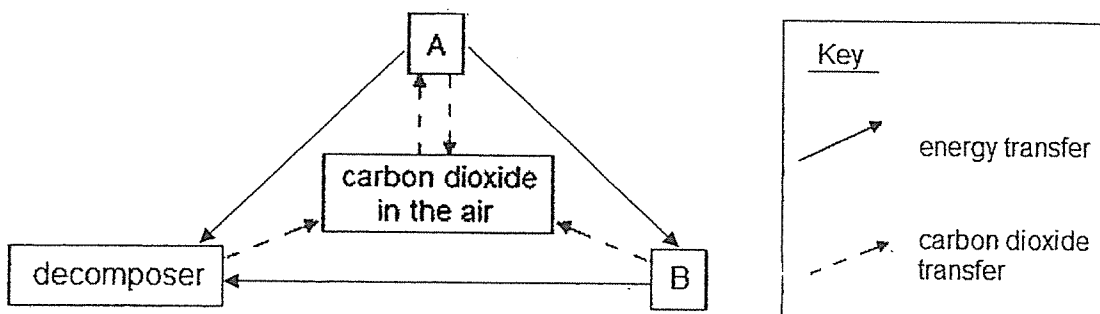

What groups of organisms do A and B represent?

	A	B
(1)	flowering plants	animals
(2)	ferns	flowering plants
(3)	animals	flowering plants
(4)	animals	ferns

12. Which of the following graphs correctly represents the change in mass of seed leaves as a seed germinates over a few days?

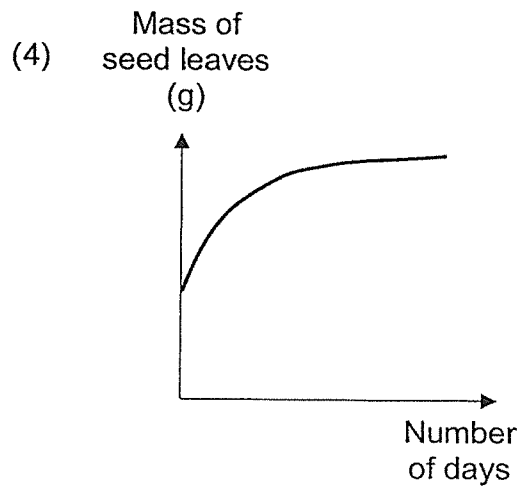
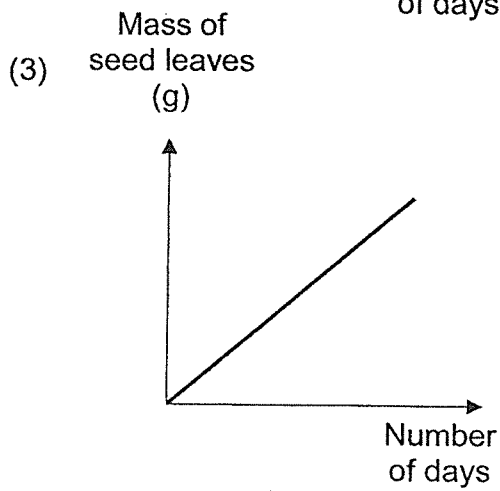
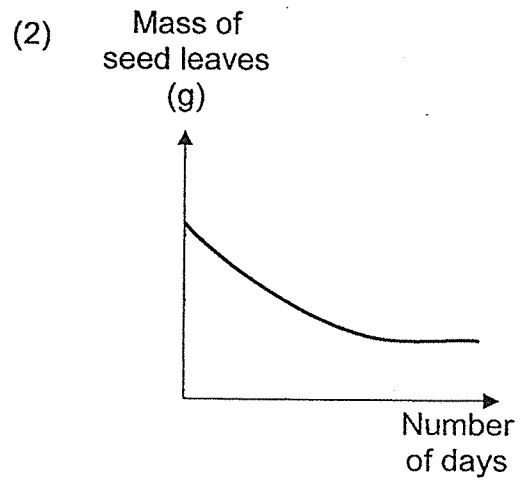
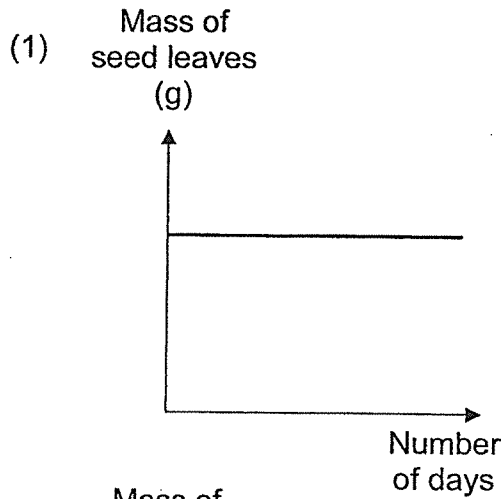

13. Three mushrooms of the same type were placed in each of the flasks A, B, C and D and kept airtight in a classroom as shown in the diagram below.

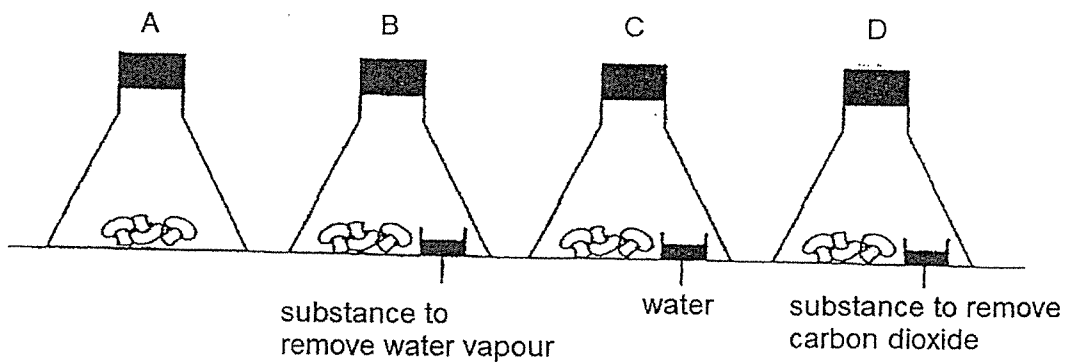

Which set-ups should be used to find out if carbon dioxide is needed for decomposition?

- (1) A and B
- (2) A and D
- (3) B and C
- (4) B and D

14. The diagram below shows an electric baby hammock that is used to help a baby sleep. It moves the baby up and down without touching the floor.

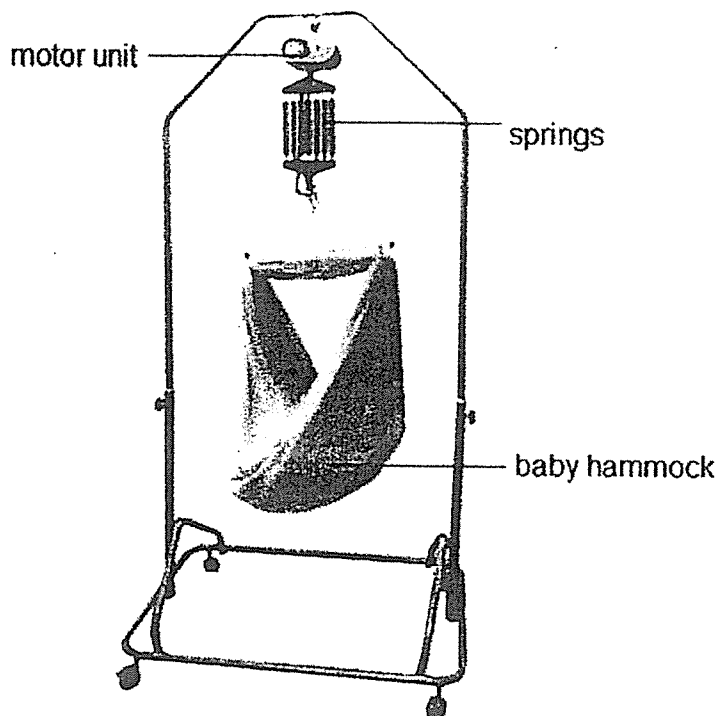

Which of the following graphs correctly shows the gravitational potential energy possessed by the baby and the amount of gravitational force that is acting on the baby?

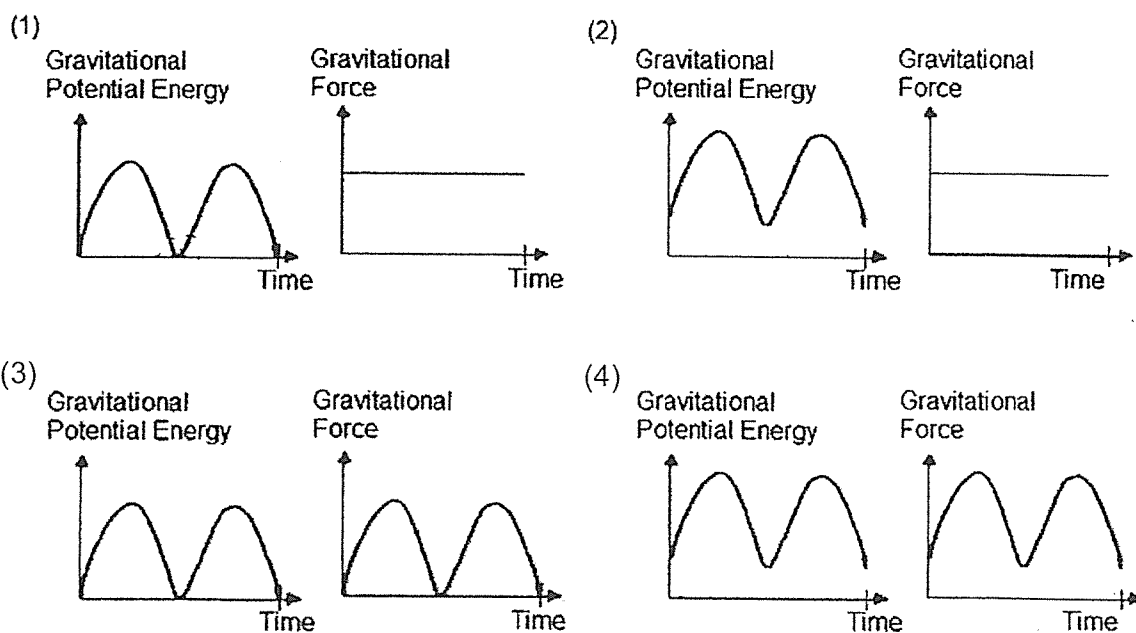

15. The set-up below shows a torchlight shining light on object P.

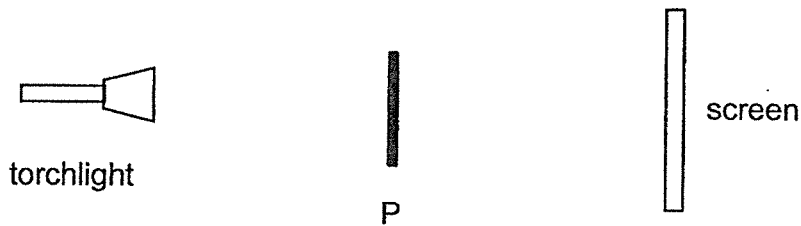

The shadow cast on the screen is shown below.

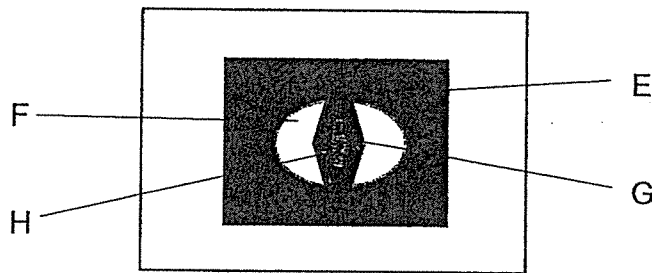

What conclusions can you draw from the observation?

- A : Part F blocked all the light from the torch.
 B : Part H allowed more light to pass through than part E.
 C : Part G allowed more light to pass through than part H.

- (1) A only
 (2) C only
 (3) A and B only
 (4) B and C only

16. The following set-ups show different ways to arrange four ring magnets, A, B, C and D, of the same mass and size.

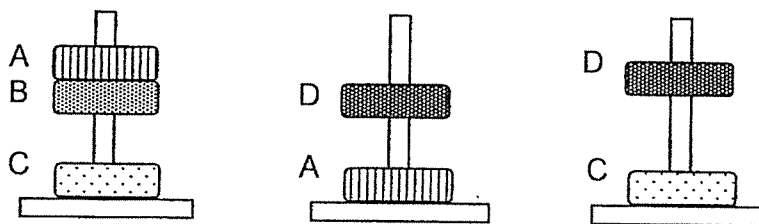

Which of the following conclusions is true about the magnets?

- (1) The like poles of all the magnets are facing each other.
 (2) The unlike poles of all the magnets are facing each other.
 (3) Magnet A has a stronger magnetic strength than Magnet B.
 (4) Magnet C has a stronger magnetic strength than Magnet A.

17. Maisie set up an experiment to compare the flexibility of supporting strips which were made of different materials.

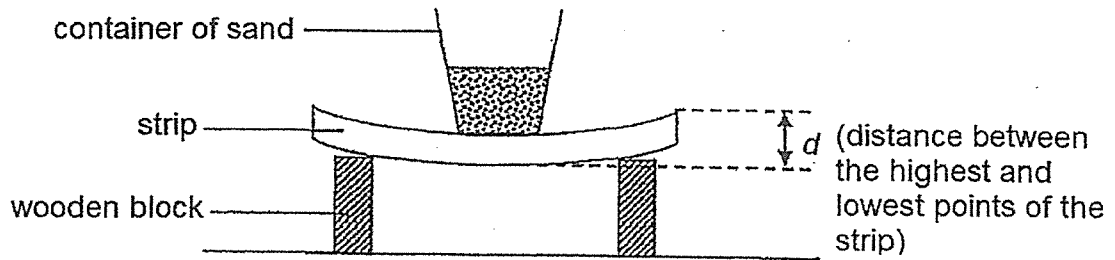

She measured and recorded distance d of each strip.

Which two variables of the strip must be kept the same so that the experiment was a fair test?

- A: colour of strip
- B: length of strip
- C: texture of strip
- D: thickness of strip

- (1) A and B
- (2) B and C
- (3) B and D
- (4) C and D

18. The diagram below shows the water cycle.

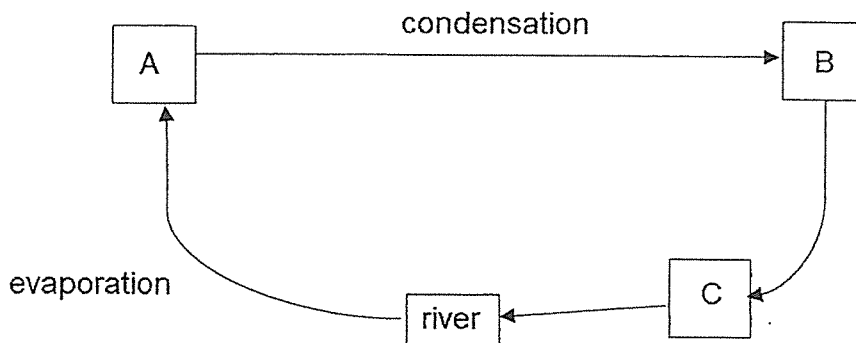

Which one of the following represents A, B and C?

	A	B	C
(1)	water vapour	clouds	rain
(2)	water vapour	rain	clouds
(3)	clouds	rain	water vapour
(4)	rain	clouds	water vapour

19. Clara left four identical beakers of water, P, Q, R and S, at different locations under different conditions. The graph below shows how the amount of water in each beaker changed over time.

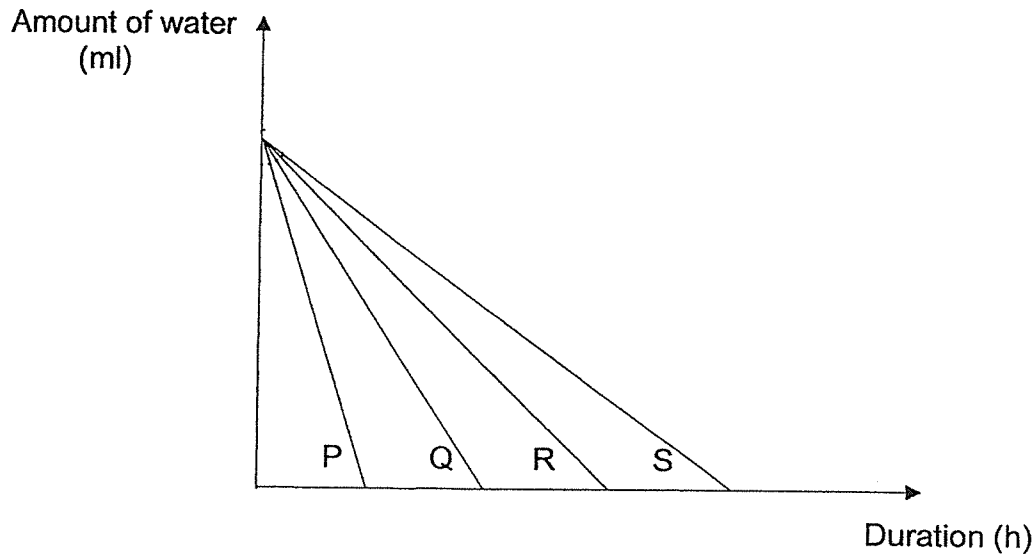

Which of the following is a possible reason to explain the difference in time taken for all the water from the four beakers to evaporate?

- (1) The temperature of the surroundings for R is higher than that of S.
 - (2) The exposed surface area of the water in Q is greater than that in P.
 - (3) There is wind in the location where S is placed but no wind where Q is placed.
 - (4) The amount of water in P is less than the amount of water in S at the start of the experiment.
20. Which of the following statement(s) correctly describe(s) the possible observation(s) after a substance loses heat?
- A: The substance expands.
B: The substance contracts.
C: The temperature decreases.
D: The mass remains the same.
- (1) A only
 - (2) B only
 - (3) A, C and D only
 - (4) B, C and D only

21. The diagram below shows a man participating in a sport called pole vaulting. From point A, he will run towards point B, lunge up into the air with the help of a pole at point C and cross the bar at point D.

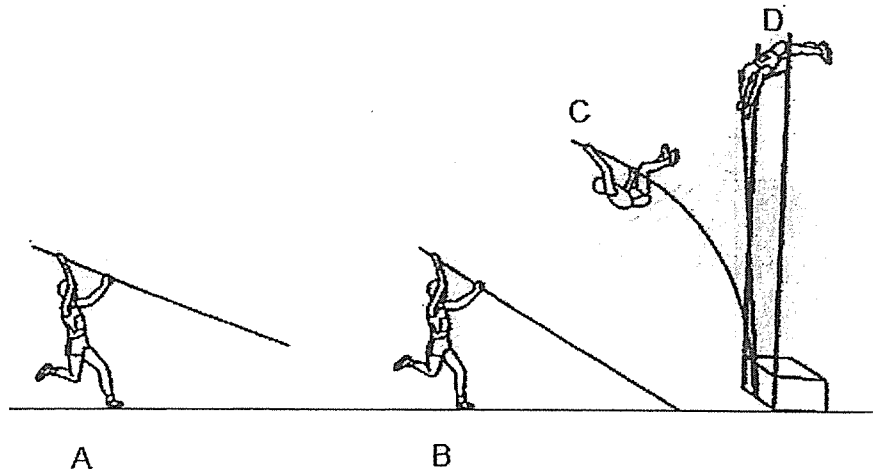

What are the main forms of energy the man possesses at points B and C?

	Point B	Point C
(1)	Gravitational Potential Energy	Kinetic Energy
(2)	Kinetic Energy + Gravitational Potential Energy	Kinetic Energy
(3)	Kinetic Energy	Kinetic Energy + Gravitational Potential Energy
(4)	Gravitational Potential Energy	Gravitational Potential Energy

22. Four objects, W, X, Y and Z, made of different materials were placed at different parts of the electrical circuit as shown below.

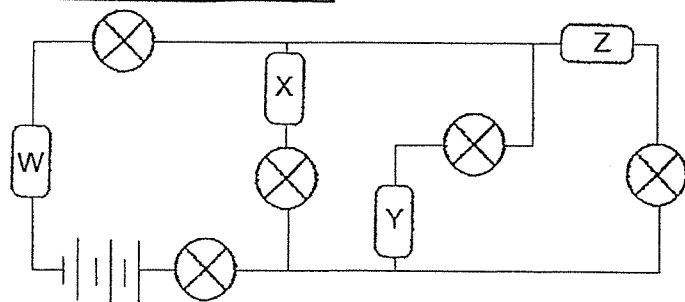

Given that none of the bulbs lighted up, which of the following correctly matches the objects to the materials they were made of?

	Silver	Plastic	Wood	Copper
(1)	W	Y	X	Z
(2)	X	Z	Y	W
(3)	X	W	Y	Z
(4)	Y	X	Z	W

23. Deforestation is harmful to our environment.

What is the impact of deforestation?

- A: More rainfall in the forest
- B: Fewer varieties of animals
- C: Less carbon dioxide in the air
- D: More soil being washed away into the rivers

- (1) A and C only
- (2) B and D only
- (3) A, B and D only
- (4) B, C and D only

24. Janice carried out an experiment using four different materials, E, F, G and H. She filled four identical beakers with the same amount of water at 60°C. Then the beakers were each wrapped with a different material.

After 10 minutes, she recorded the temperature of water in each beaker in the table below.

Material used to wrap the beakers	Temperature (°C) after 10 minutes
E	40
F	35
G	45
H	50

Which material should Janice choose to make an ice box that will keep the ice from melting for the longest possible period of time?

- (1) Material E
- (2) Material F
- (3) Material G
- (4) Material H

25. Sandra took a beaker of ice cubes out from the freezer and placed it on a heat source. After some time, she turned off the heat source and left the beaker of ice cubes on the kitchen table to cool. The graph below shows the temperature changes after Sandra took the ice cubes out from the freezer.

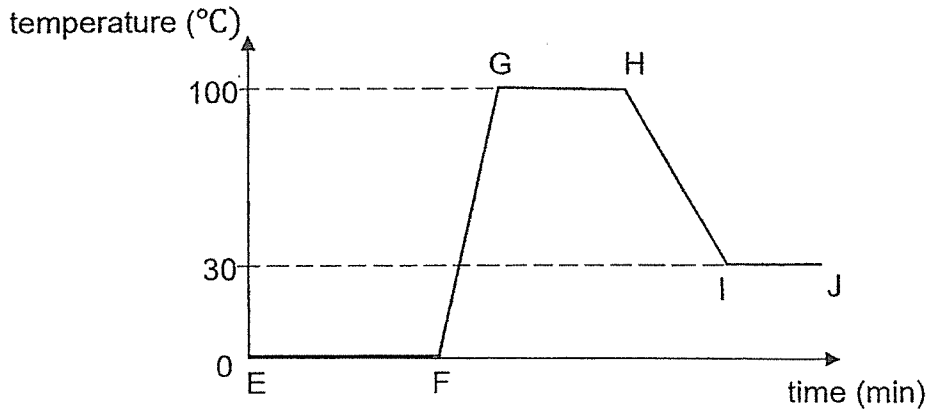

Based on the graph, which of the following statements is/are true?

- A : There was no heat gain at EF.
- B : The heat source was turned off at G.
- C : Evaporation does not take place at IJ.
- D : Water exists in liquid and gaseous states at GH.

- (1) A only
- (2) D only
- (3) B and C only
- (4) A, C and D only

26. The diagram below shows a spring balance being used to pull a wooden block up a ramp.

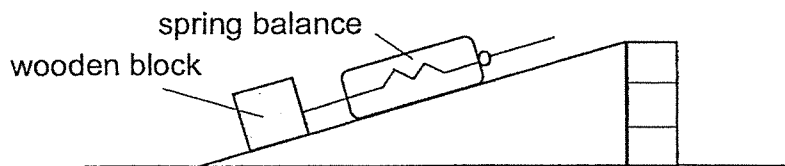

Which change would require more force to pull the wooden block up the ramp?

- (1) Applying oil to the wooden block
- (2) Reducing the mass of the wooden block
- (3) Sticking a sheet of sandpaper to the surface of the ramp.
- (4) Decreasing the height of the ramp by removing one of the cubes.

27. The set-up below uses a light sensor to count the number of objects on a moving belt over a period of 20 seconds.

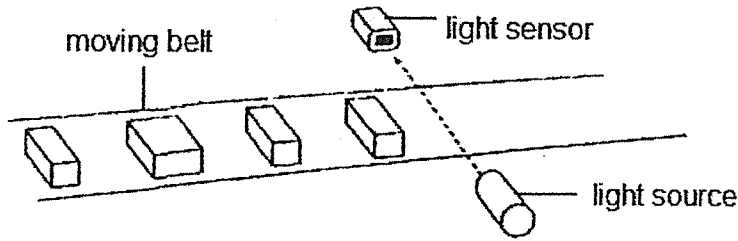

The belt moves at a constant speed. The four objects are either opaque or translucent and come in two sizes. Which of the following graphs correctly shows the amount of light detected by the light sensor?

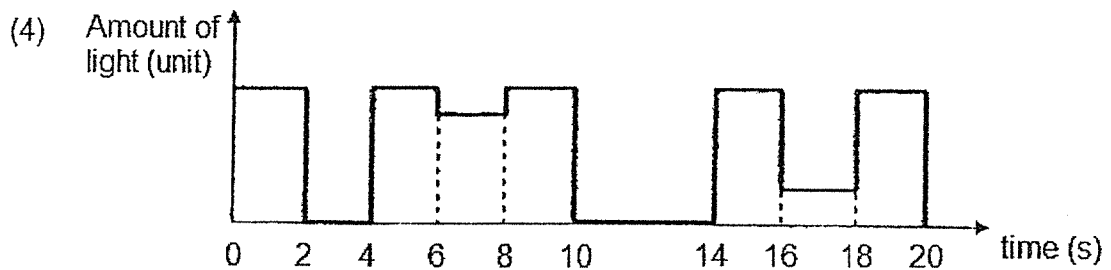
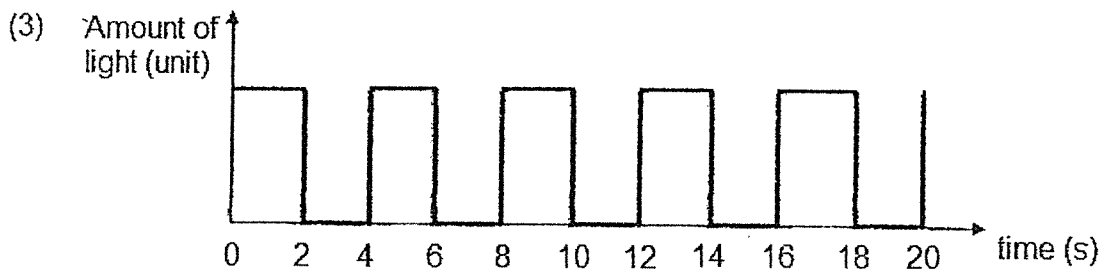
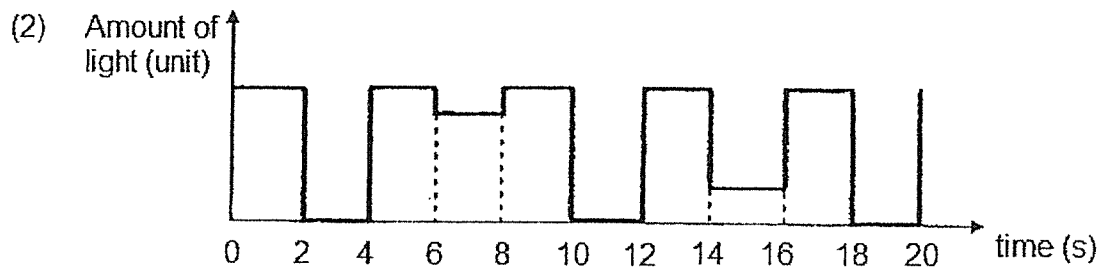
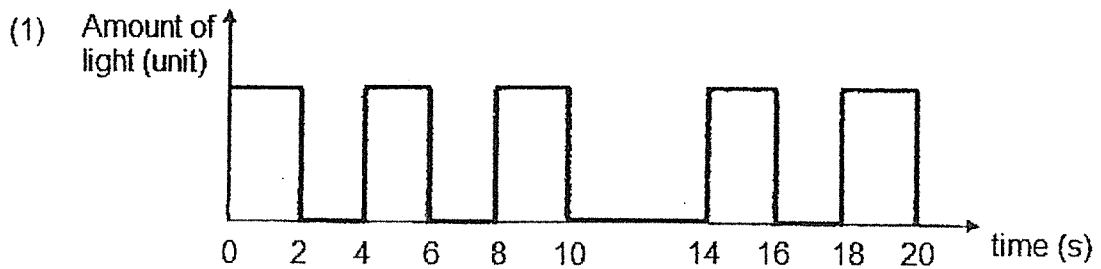

28. Figure 1 shows the position of rod X after Sandra brought a magnet close to it. She then placed a flame near one end of rod X as shown in Figure 2 and observed that rod X started to move towards the magnet.

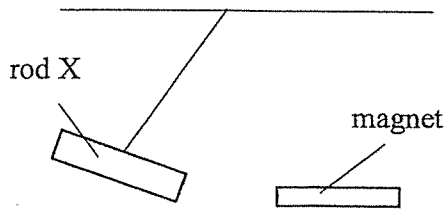

Figure 1

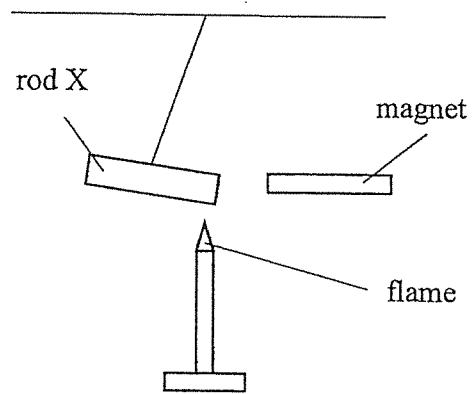

Figure 2

Which of the following explains why rod X started to move towards the magnet?

- A : Rod X was pulled down because gravity increased.
- B : Rod X had lost some of its magnetism.
- C : Rod X expanded and increased in mass.

- (1) B only
- (2) C only
- (3) A and B only
- (4) All of the above

End of Booklet A

Index No.

--	--	--	--	--	--	--

Name : _____ ()

Class : Primary 6 SY / C / G / SE / P

24 August 2023



SINGAPORE CHINESE GIRLS' SCHOOL
SECOND SEMESTRAL ASSESSMENT 2023

PRIMARY 6

SCIENCE

BOOKLET B

Total Time for Booklets A and B: 1 h 45 min

INSTRUCTIONS TO CANDIDATES

1. Do not turn over this page until you are told to do so.
2. Follow all instructions carefully.
3. Answer all questions.
4. Write your answers in this booklet.

	Max Mark	Marks attained
Booklet A	56	
Booklet B	44	
Total Marks	100	

Parent's Signature

This booklet consists of 15 printed pages and 1 blank page.

Part II (44 marks)

For questions 29 to 41, write your answers in this booklet.

The number of marks available is shown in brackets [] at the end of each question or part question.

29a. The diagram below shows a typical plant cell.

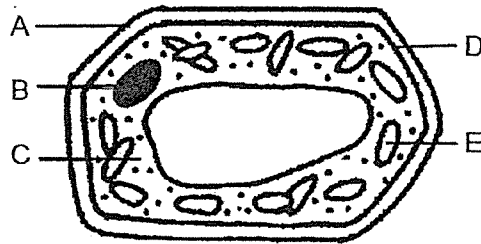

- i. Match the cell part, A, B, C, D and E to their corresponding function/description by filling in the box with the correct letter. (2m)

Function/Description	Cell Part/s
Allows only certain substances to pass in and out of the cell.	
Controls all activities of the cell.	
Not found in animal cells	

- ii. Which cell part A, B, C, D or E is **not** found in a root cell. Explain. (1m)

29b. Mary removed a ring of bark from the stem of a plant as shown in the diagram below. Removing the ring of bark took away the food-carrying tubes but not the water-carrying tubes.

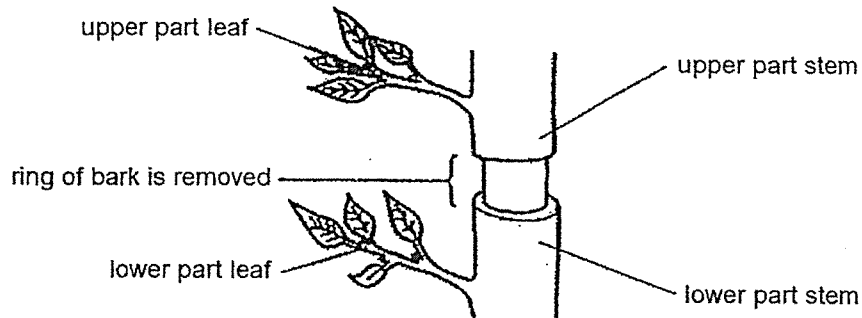

Circle the correct options to show the effect of removing the ring of bark on the following stem parts after a week: (2m)

Upper part		Lower part	
<u>Stem:</u>	<u>Leaf:</u>	<u>Stem:</u>	<u>Leaf:</u>
No change / swollen	green / yellow	No change / swollen	green / yellow

30. Katherine placed the same amount of meat into each of the set-ups X, Y and Z, as shown in the diagram below. The meat was cut up into two pieces for set-up Y and in four pieces for set-up Z. She then placed the meat into equal volumes of digestive liquid P.

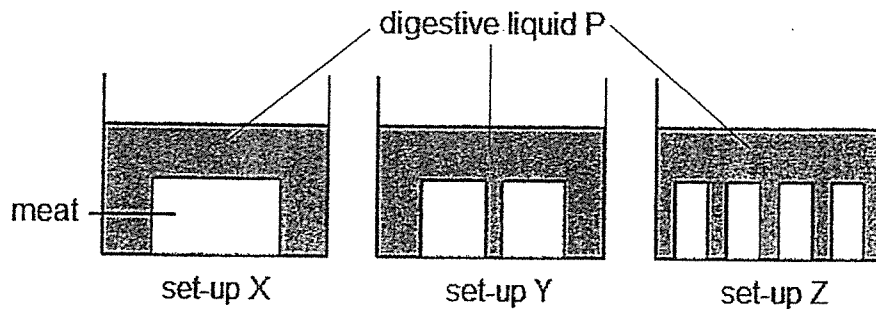

After 30 minutes, she recorded the results in the table below.

Set-up	Total mass of meat (g)	
	At the start of the experiment	After 30 minutes
X	100	92
Y	100	83
Z	100	78

- a. By cutting the meat into different sizes, what variable was Katherine trying to change? (1m)

- b. Explain why the mass of the meat is reduced. (1m)

- 31a. Maisie had watery stools. Her mother told her that there could be something wrong with her digestive system.

Identify the part of the digestive system that could cause Maisie's stools to be watery. Explain its function. (2m)

- 31b. Mrs Tan is pregnant. Besides her reproductive system, state two other systems that work together to provide food for her developing baby. (1m)

32. Kaixin identified all the different organisms and its population in habitat Z. She drew out a graph with the different organisms as shown below.

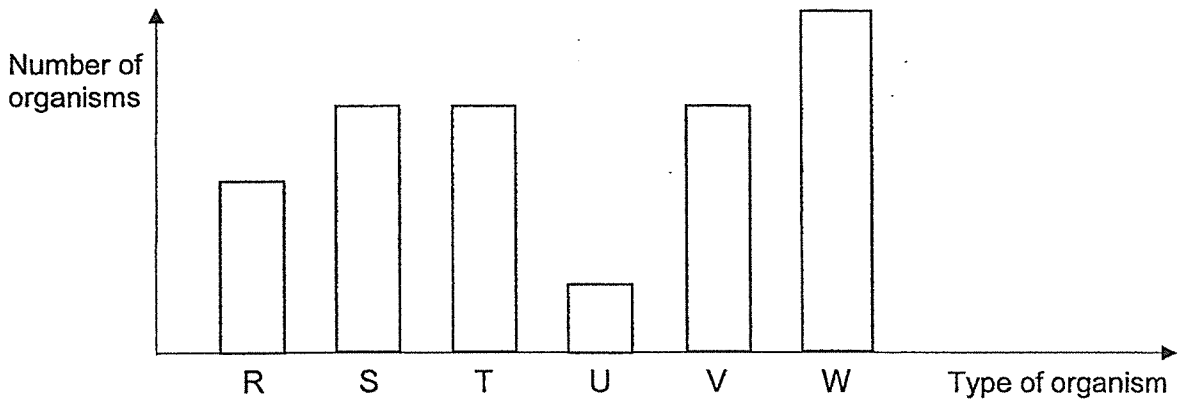

With further observations, she listed down the interactions between some organisms as shown below.

- U eats R, S and T
- R eats V and W
- S, T and V are herbivores

a. Based on all the information above, draw out the food web that best represents all the organisms in habitat Z. (2m)

b. The starting population of S, T and V are the same. When organism W decreases, organism V's population will decrease faster than organism S's and T's. Explain. (2m)

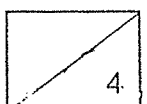

- 33a. Pam conducted an experiment using four similar fruits from a plant that disperses its seeds by splitting. She subjected the four fruits to different temperatures and measured the time taken for the fruits to split. The results are shown in the table below.

	Fruit E	Fruit F	Fruit G	Fruit H
Surrounding Temperature (°C)	15	20	35	30
Time taken for the fruit to split (h)	20	12	2	3

- i. What is the relationship between the surrounding temperature and the time taken for the fruit to split? (1m)

- ii. After splitting, the seeds from fruits E, F, G and H are dispersed by wind. The two graphs below are drawn by Pam's classmates, Chloe and Rina, to show the relationship between the strength of wind and the distance the seeds are dispersed.

Distance the seeds are dispersed

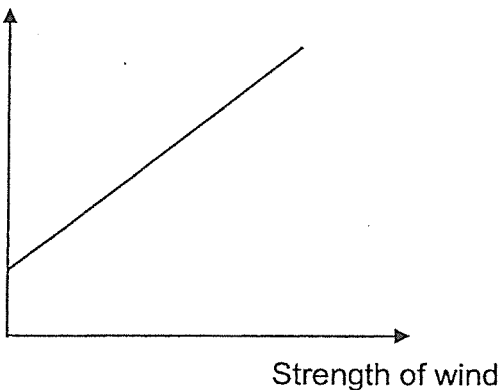

Chloe's graph

Distance the seeds are dispersed

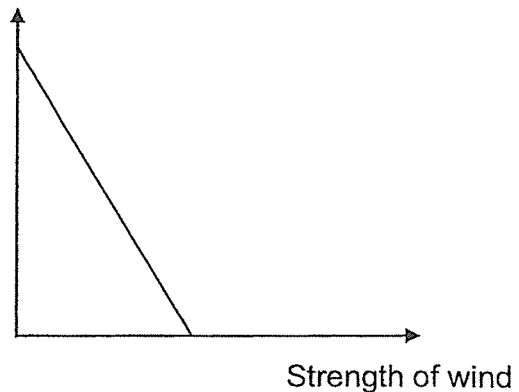

Rina's graph

- Who is correct? Explain your answer. (1m)

- iii. How does being carried further by the wind help a seed in its reproduction? (1m)

- b. Pam conducted another experiment to find out how the distance of pollen grains from the nectar would affect the amount of pollen grains collected by Insect A. She used liquid P which attracts Insect A to set up the experiment as shown below. She filled the ends of each rod with 50 pollen grains.

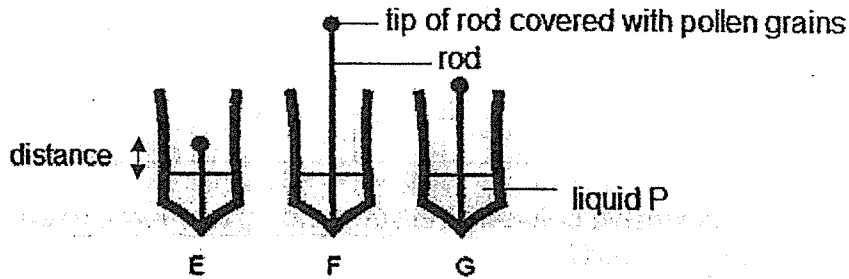

Pam observed that Insect A visited each set-up the same number of times and recorded the amount of pollen grains left on the rod in the table below.

Set-up	E	F	G
Amount of pollen grains left on the tip of the rod	2	48	35

- i. Explain why insect A collected most pollen grains from set-up E. (1m)

- ii. Besides animals, state one other agent of pollination. (1m)

34. Elena wanted to find out how arranging bulbs in series or parallel affects the brightness of the bulbs in a closed circuit. To start the experiment, she used similar bulbs and batteries for circuits P and Q.

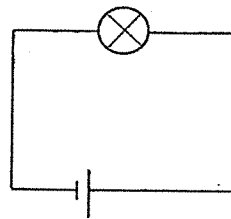

Circuit P

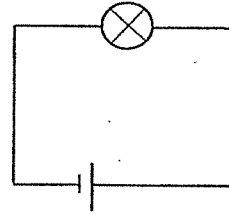

Circuit Q

She added one bulb at a time to each circuit and observed the brightness of the bulbs in each circuit. She then plotted the results in the graph shown below.

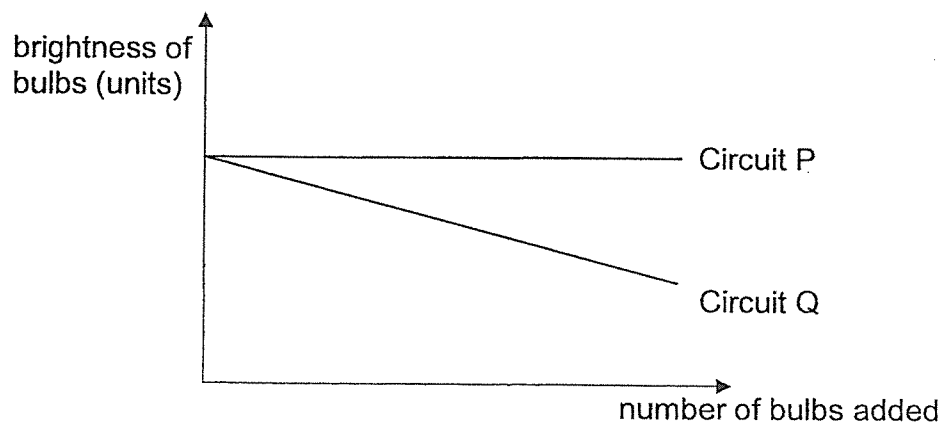

- a. Explain why there is a difference in the brightness of the bulbs in circuit P and circuit Q as more bulbs are added. (2m)

- b. Based on your answer in (a), will the rest of the bulbs light up in each circuit if one bulb in each circuit is fused? (1m)

One fused bulb in circuit :	Will the other bulbs light up? (Yes/No)
P	
Q	

35. Four metal balls A, B, C and D are suspended on a string from the ceiling. The strings holding the four balls are cut and the balls are dropped from different heights as shown in the diagram below. Each ball created a depression on a bed of sand below it when it hit.

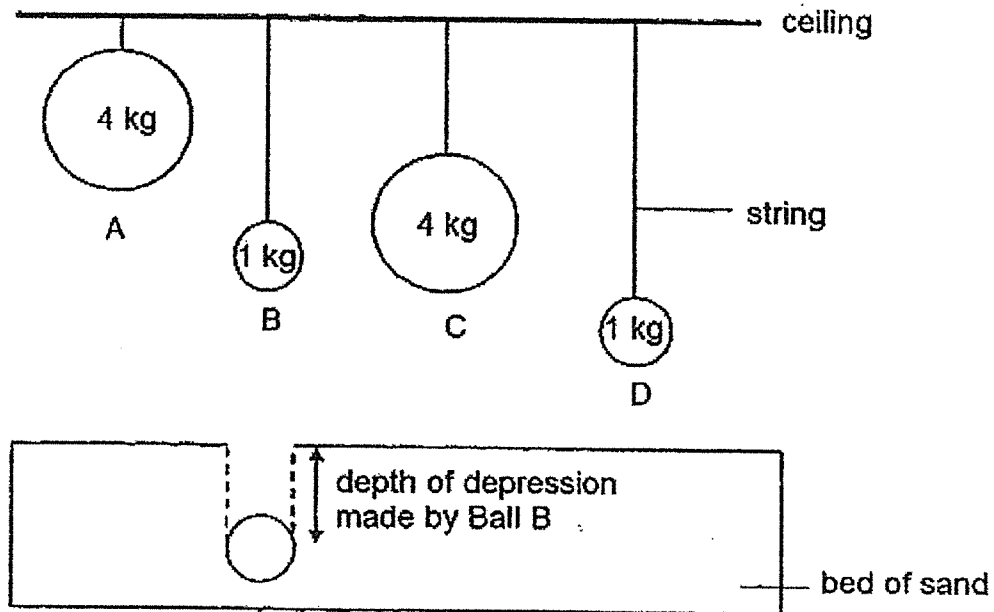

- a. In the bar graph below, fill in the boxes with A, C and D to indicate the correct graph for the depth of depression made by balls A, C and D. (2m)

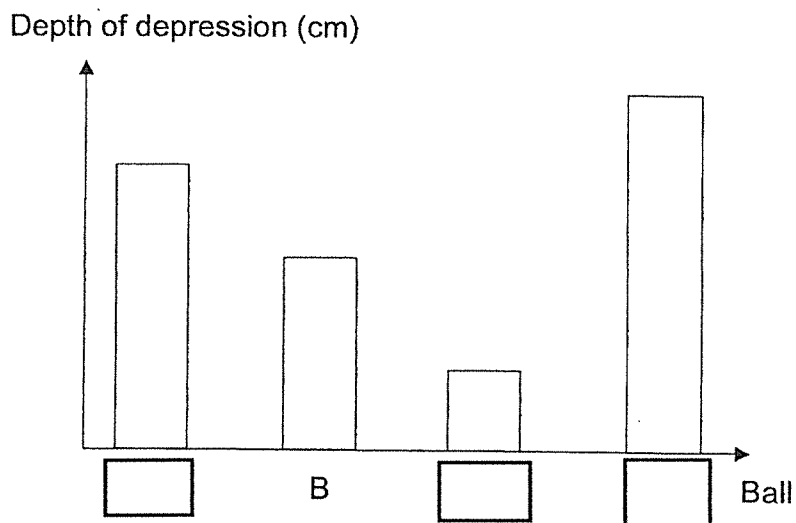

- b. Fill in the boxes to show the energy conversion from the point the string is cut till when the ball hits the bed of sand below. (1m)

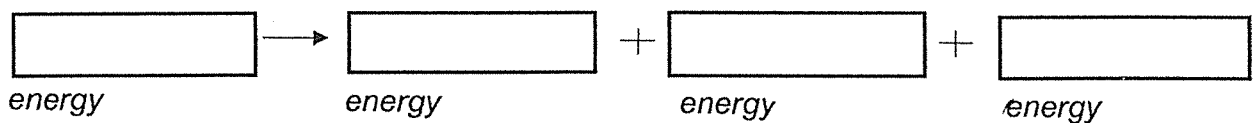

36a. State the meaning of melting point.

(1m)

36b. Tiffany placed a solid made of substances R, S and T in the set-up as shown below.

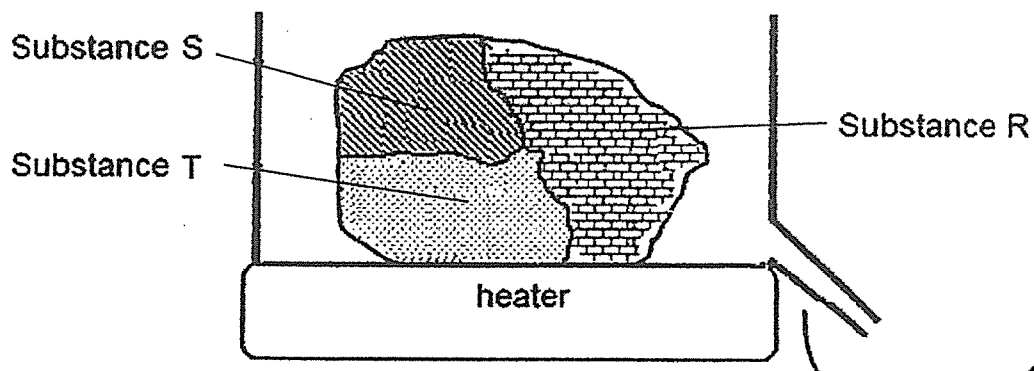

The table below shows the melting points of the three substances.

Substance	R	S	T
Melting point (°C)	55	80	30

She wanted to ensure that the solid does not contain substance R and T and needs to decide what temperature to set the heater.

Her classmates Rachel and Therese offer her the following suggestions:

Rachel : *Set the temperature to 70 °C.*

Therese: *Set the temperature to 50 °C.*

Who is correct? Explain your answer.

(1m)

37. Wendy carried out an experiment testing three clips X, Y and Z, made of different materials, in the set-up shown below. The clips were of the same size.

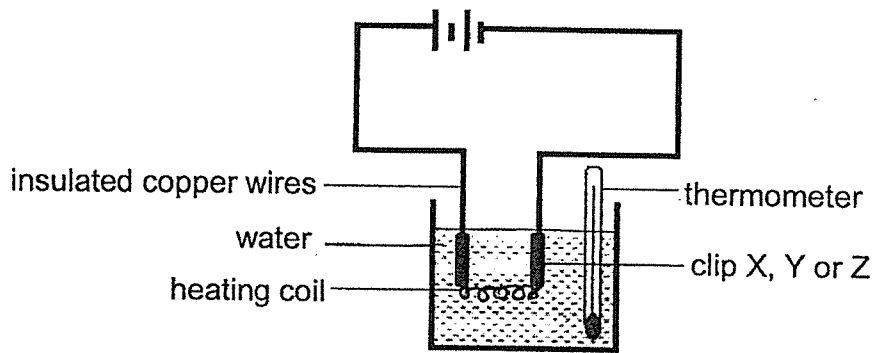

She connected one of the clips to the circuit and measured the temperature of the water at the end of the experiment. The experiment was repeated for the other two clips. The table below shows the results of the experiment.

	Temperature of water (°C)		
	Clip X	Clip Y	Clip Z
Start	30	30	30
End	30	100	100

- a. What is the aim of Wendy's experiment? (1m)

- b. Based on the results, what can you conclude about clips X, Y and Z? (2m)

38. Yiling conducted an experiment with two objects, P and Q, of the same mass. Both objects are submerged in water and connected to weights of 100 g. The weights are used to pull the objects across in a 1-metre tank of water. Her experiment set-up is shown below.

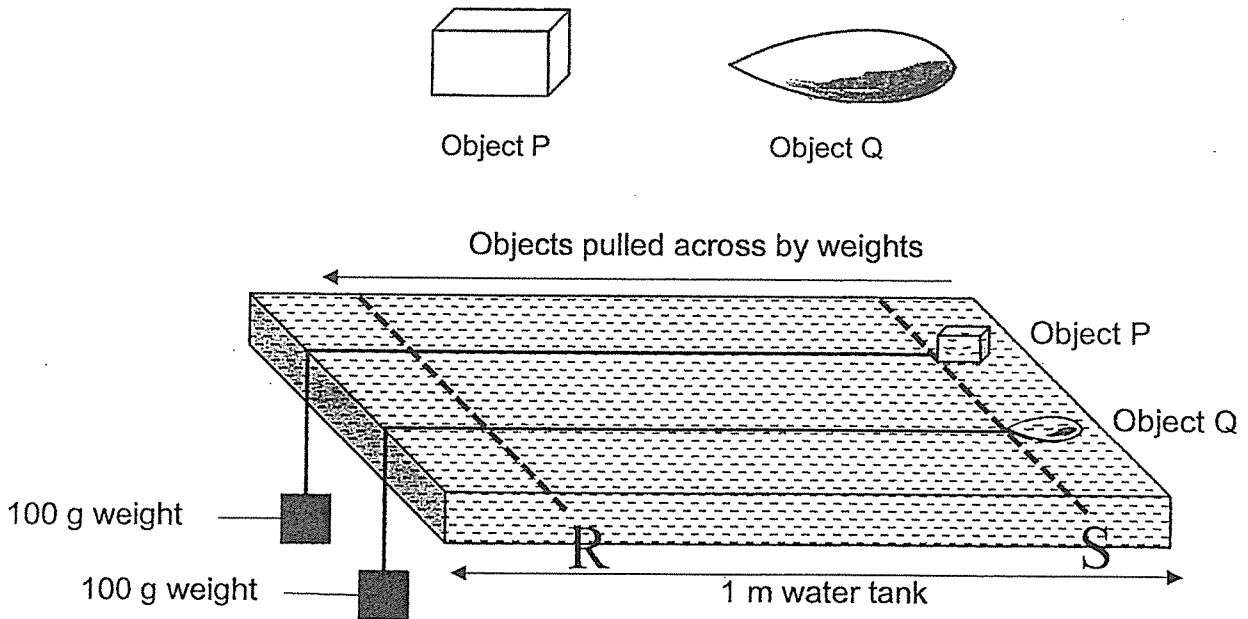

The table below shows the results of her experiment.

- ai. Complete the table by filling in 'P' and 'Q' to match the time taken for the object to move across the tank with the correct object. (1m)

Object	Time taken for object to move from starting line S to ending line R
<input type="checkbox"/>	12 seconds
<input type="checkbox"/>	7 seconds

- aii. Explain your answer in (ai). (1m)

- b. What can Yiling do to improve the reliability of her experiment? (1m)

c. Look at animal D shown below.

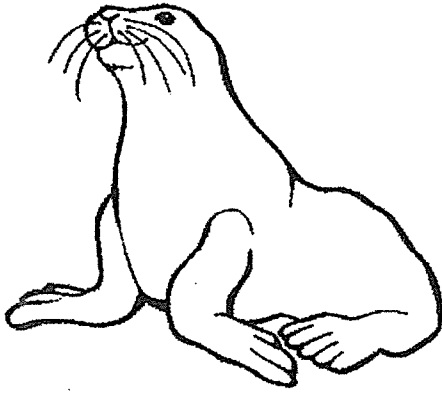

Animal D on land

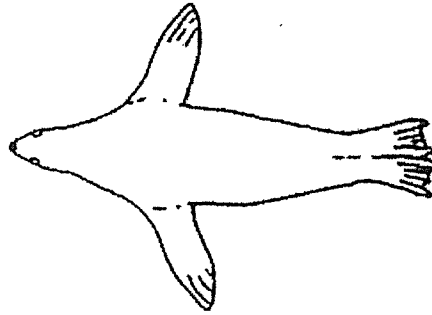

Animal D in water (view from above)

Based on Yiling's experiment, state 2 ways how animal D's body shape in water benefits it. (2m)

Benefit 1: _____

Benefit 2: _____

39. Jessica went for a hike at Bukit Timah Hill. She walked from point W to Z without stopping. The amount of gravitational potential energy she has at the different points during the hike is shown in the graph below.

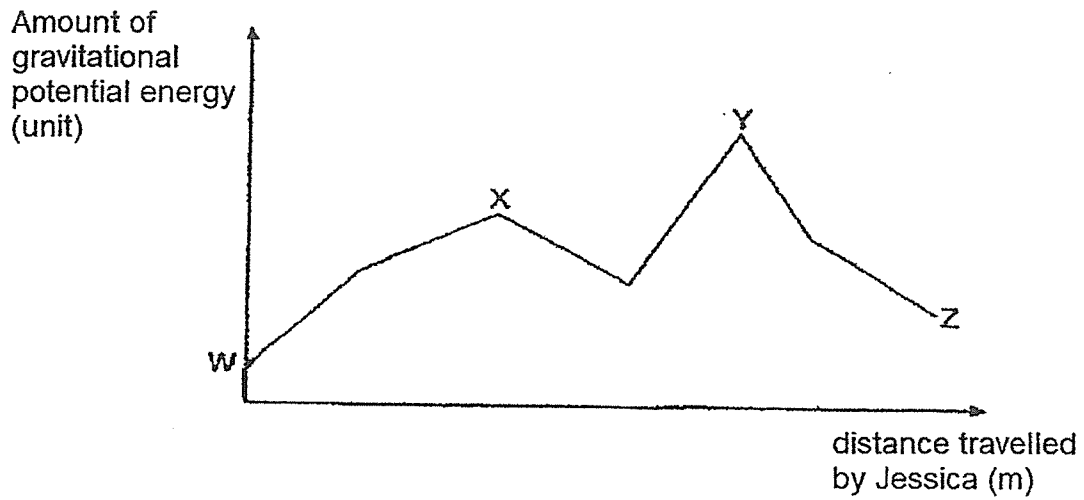

Based on the graph above, put a tick in the correct box to indicate if each of the following statements are true or false. (2m)

		True	False
i.	Jessica was at ground level at point W.	<input type="checkbox"/>	<input type="checkbox"/>
ii.	Jessica did not possess any kinetic energy at point Y.	<input type="checkbox"/>	<input type="checkbox"/>
iii.	Jessica was at the highest point of the hike at point Y.	<input type="checkbox"/>	<input type="checkbox"/>
iv.	Jessica was climbing down a slope from point W to point X.	<input type="checkbox"/>	<input type="checkbox"/>

40a. The diagram below shows the negative impacts, A, B, C and D, on the environment due to some human activities.

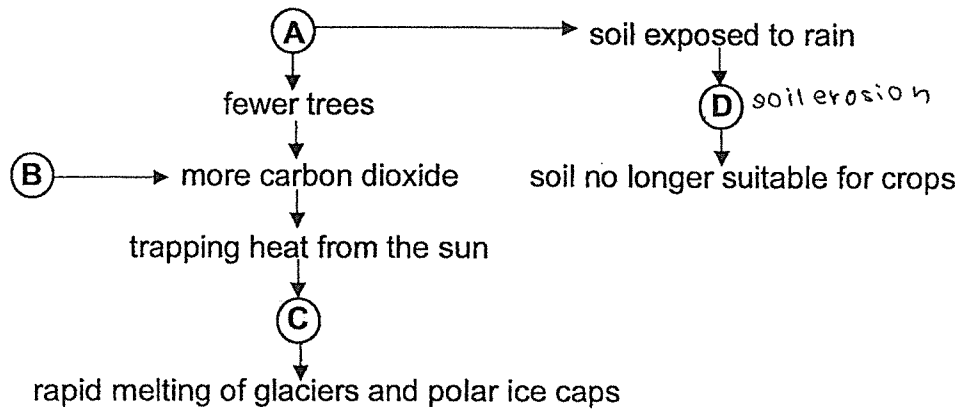

Fill in the boxes with A, B, C or D to match the following activities to the letter it best represents in the diagram above. (2m)

	Human Activity	Letter
i.	Soil Erosion	
ii.	Deforestation	
iii.	Global Warming	
iv.	Burning Fossil Fuels	

b. The Pollutant Standards Index (PSI) is a type of air quality index that indicates how polluted the air is.

The map below shows the PSI of different locations in Country K. Country K is experiencing hazy conditions due to a forest fire in Country L.

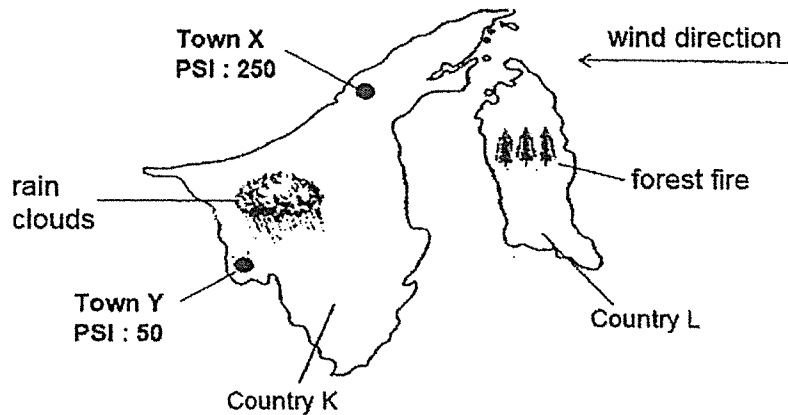

Based on the information provided in the diagram above, give two reasons to explain why the PSI in Town X is higher than the PSI in Town Y. (2m)

Reason 1 : _____

Reason 2 : _____

41. The diagram below shows a balance with two metal blocks, A and B. The balance is horizontal when A and B are placed on it.

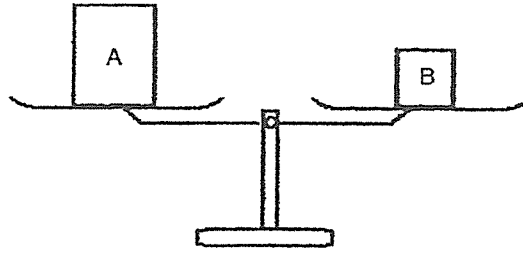

- a. The metal block A is then heated as shown in the diagram below.

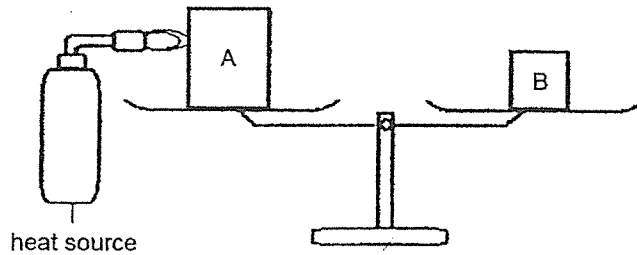

- i. What will happen to metal block A after it is heated for some time? (1m)

- ii. Will metal block A move up, move down or remain in the same position on the balance when it is heated? Explain your answer. (1m)

- b. After block A has cooled down to room temperature, both A and B are then placed in identical containers which are then filled with a similar liquid to the brim.

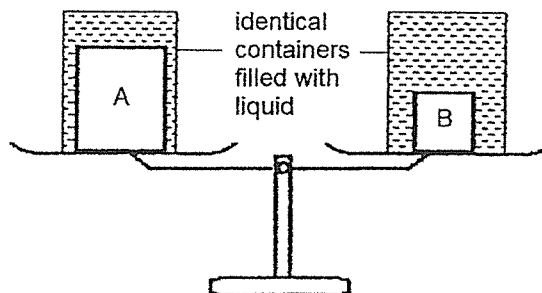

- On the balance, will the container with metal block A move up, move down or remain in the same position on the scale balance? Explain your answer. (1m)

End of Booklet B



NAME: _____ () Class: 6

2023 SINGAPORE CHINESE GIRLS' SCHOOL
P.6 SCIENCE 2023 PRELIMS

Booklet A (56m)

1.	1	6.	3	11.	1	16.	4	21.	3.	26.	3
2.	4	7.	3	12.	2	17.	3	22.	3	27.	4
3.	4	8.	1	13.	2	18.	1	23.	2	28.	1
4.	2	9.	3	14.	2	19.	1	24.	4		
5.	4	1	1	15.	4	20.	4	25.	2		

Booklet B (44m)

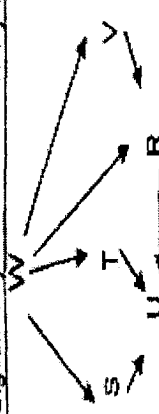
S/N	Recommended Answers
29ai	Allows only certain substances to pass in and out of the cell. Controls all activities of the cell. Not found in animal cells
29aii	E. Roots have no chlorophyll / don't need to photosynthesize.
29b	Upper: Swollen Lower: No change Green
30a	Surface area of meat in contact with/ exposed to liquid P
30b	The meat was digested / broke down into simpler substances.
31a	Large intestine. It absorbs water from the undigested food.
31b	Digestive system and Circulatory system
32a	
32b	R has less W to eat so R needs to eat more V.
33ai	The higher the temperature, the shorter the time taken for the fruit to split. OR -- lower --, -- longer the time --
33aii	Chloe. The stronger the wind, the further the distance the seeds will be dispersed.
33	The seed can be dispersed further from the parent plant and can reduce overcrowding/ reduce competition for light, water, mineral salts and space.
33bi	The distance between the nectar / liquid P and the tip of the rod is the shortest

	OR The pollen is nearest to the nectar.
33bi	Wind OR Water
34a	As the number of bulbs increase, the brightness of the bulbs in circuit P remain the same as the bulbs are arranged in a parallel. As the number of bulbs increase, the brightness of the bulbs in circuit Q decreases as the bulbs are arranged in series.
34b	P - YES Q - NO
35a	C B D A
35b	Potential → Kinetic + Heat + Sound
36a	Melting point is a fixed temperature at which a substance changes from solid to liquid state.
36b	Rachel is correct. 70°C is above R and T's melting point but below melting point of S OR R and T will melt but S will not melt/ stay a solid.
37a	To find out which material is a conductor / insulator of electricity.
37b	B and C are conductors of electricity but A is an insulator of electricity/not a conductor of electricity.
38ai	Object P Q
38aii	Q is more streamlined in shape than P so Q will move/ swim faster than P in water.
38b	Repeating her experiment a few times enables her to increase the reliability of her results.
39	F, F, T, F
40a	D, A, C, B
40b	<ul style="list-style-type: none"> The rain has washed away some of the air pollutants in the air in Town Y. The wind has blown the air pollutants from the forest fire in Country L to town X X is nearer to the fires than Y
41a	Metal block A will gain heat and expand.
41b	It will remain in the same position / will r There is no change in mass (when metal block A expands).
41c	Metal block A will move up. Container with A has less liquid and will have less mass.