

**RAFFLES GIRLS' PRIMARY SCHOOL
PRELIMINARY EXAMINATION
PRIMARY SIX
2023**

**SCIENCE
(BOOKLET A)**

Name: _____ ()

Date : 28 August 2023

Class: P6 _____

Total Time: 1h 45min

INSTRUCTIONS TO CANDIDATES

1. Write your name, class and index number in the spaces provided above.
2. Do not turn over this page until you are told to do so.
3. Follow all instructions carefully.
4. Answer all questions.
5. For Question 1- 28, use 2B pencil to shade your answers on the Optical Answer Sheet (OAS).

Booklet A	56
Booklet B	44
Your score out of 100	
Parent's signature	

1. The following show the characteristics of organism X.

- A It has wings.
- B It has six legs.
- C It has three body parts.
- D It reproduces by laying eggs.

Which of the following characteristic(s) show(s) that organism X is an insect?

- (1) B only
- (2) B and C only
- (3) A and D only
- (4) A, B, C and D

2. The table shows the characteristic(s) of plants, A, B, C and D. A tick (✓) shows the presence of the characteristic.

Characteristic	Plant			
	A	B	C	D
Bears fruit				
Grows on land	✓			

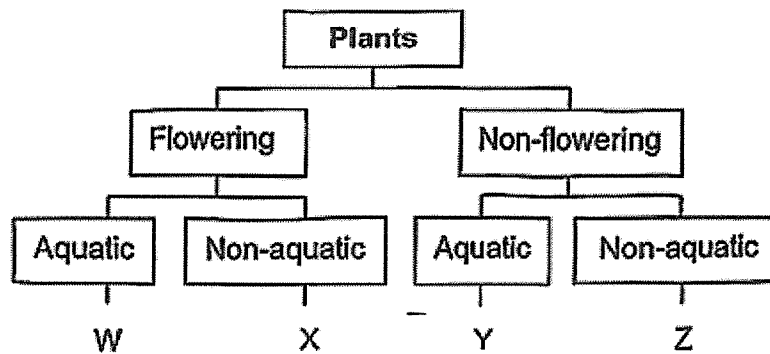

Based on the information above, which of the following, W, X, Y and Z, most likely represent plants B and C in the classification table?

	Plant B	Plant C
(1)	W	Y
(2)	X	Z
(3)	Y	X
(4)	Z	W

3. The diagram shows the processes, A, B, C and D, involved in the life cycle of a flowering plant.

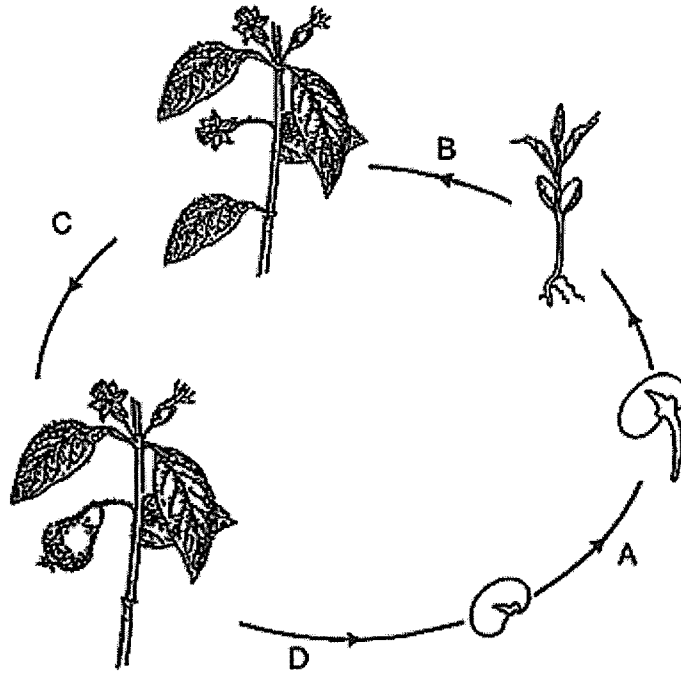

Which of the following identifies the processes of germination, fertilisation, and seed dispersal in the diagram correctly?

	Germination	Fertilisation	Seed dispersal
(1)	A	C	D
(2)	B	A	C
(3)	C	D	B
(4)	D	B	A

4. The graph shows the number of days in each stage of the life cycle of an insect.

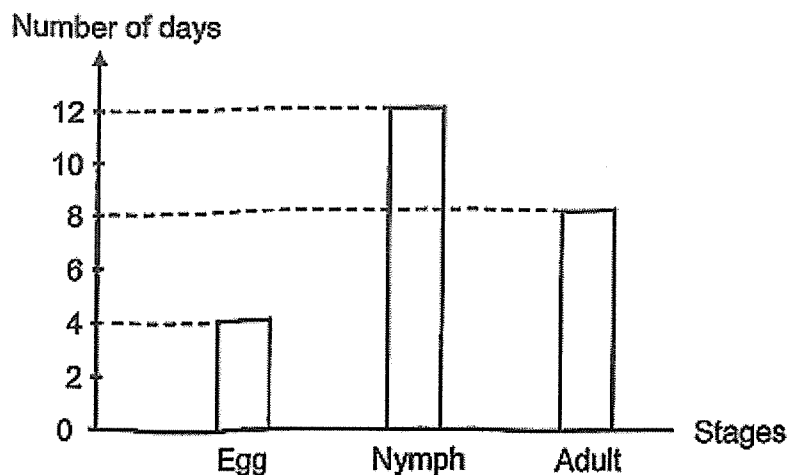

Based on the graph, which of the following statement(s) about the insect is/are true?

- A The insect is a nymph for twelve days.
- B The insect can only survive for eight days.
- C There are three stages in the life cycle of this insect.
- D It takes twenty-four days to become an adult after the egg is laid.

- (1) B only
- (2) A and B only
- (3) A and C only
- (4) A, C and D

5. The diagram shows the female reproductive system of a human.

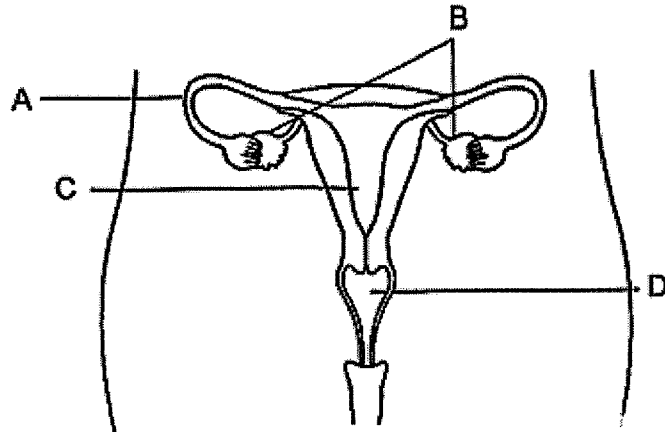

In which part of the female reproductive system, A, B, C or D, are eggs produced?

- (1) A
- (2) B
- (3) C
- (4) D

6. The diagrams show some fruits X, Y and Z (not drawn to scale).

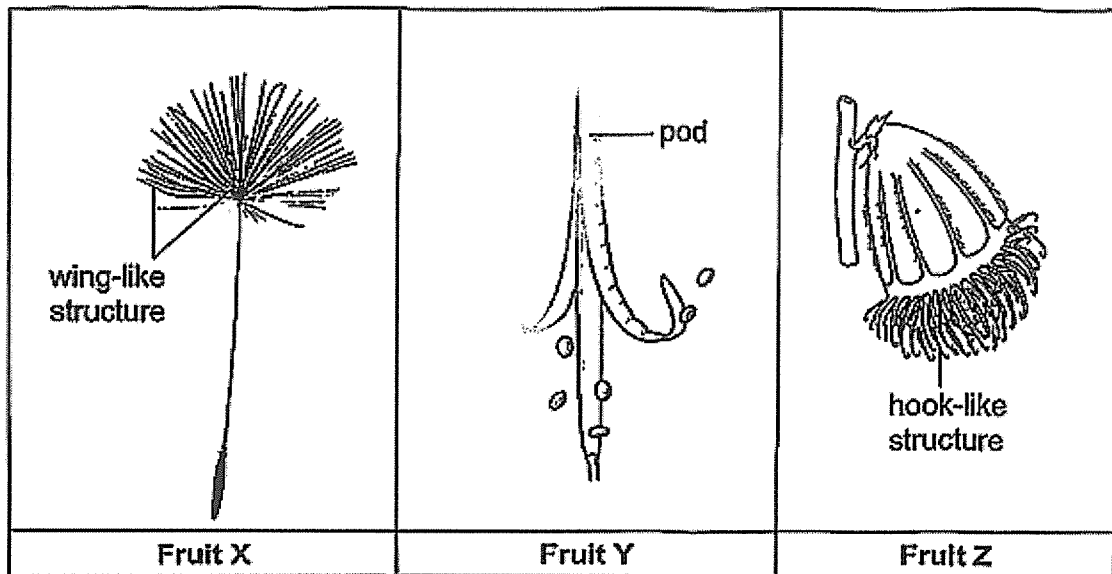

Which of the following correctly shows how fruits X, Y and Z are being dispersed?

	Fruit X	Fruit Y	Fruit Z
(1)	By animal	By wind	By water
(2)	By splitting	By water	By wind
(3)	By water	By animal	By splitting
(4)	By wind	By splitting	By animal

7. Which of the following human body systems work together when a student is eating her snack?

- A Skeletal
- B Digestive
- C Muscular
- D Reproductive

- (1) A and B only
- (2) A, B and C only
- (3) B, C and D only
- (4) A, B, C and D

8. Mary placed a plant without its roots into a beaker of blue-coloured water near the window. She cut and removed the outer ring in one part of the stem and observed the plant for two weeks.

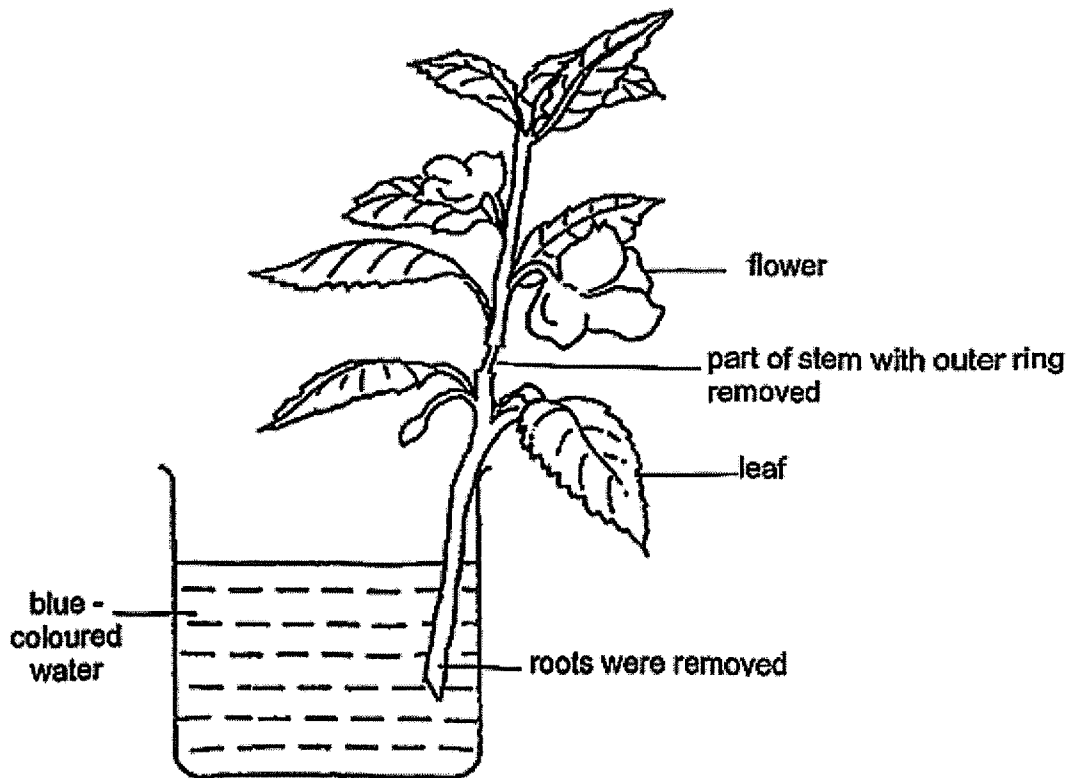

After two weeks, she observed that the flowers turned blue and only the leaves above the cut were bigger than the leaves below the cut.

Based on the information above, which of the following statements is definitely correct?

- (1) The leaves below the cut cannot make any food.
- (2) The leaves above the cut were able to make food.
- (3) The leaves below the cut did not receive any water.
- (4) The leaves above the cut cannot receive any water.

9. Two cell samples were viewed under a microscope as shown in the diagrams.

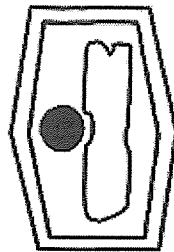

Cell A

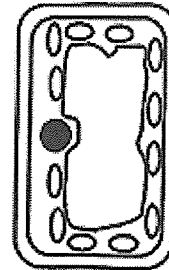

Cell B

Based on the diagrams, which of the following is correct?

- (1) Cell A is an animal cell and cell B is a plant cell.
 - (2) Cells A and B can be found in the leaves of a plant.
 - (3) Cell A is found in an underground stem of the potato plant.
 - (4) Both cells can photosynthesise in the presence of sunlight.
10. The graph shows the change in the population of plant Y in a farm.

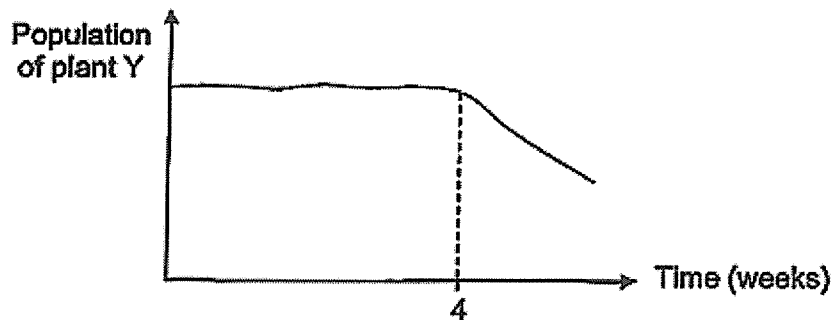

Organisms Z were spotted in the farm from week four.

Which of the following best explains the change in the population of plant Y?

- (1) Organism Z fed on plant Y.
- (2) Plant Y was harmful to organism Z.
- (3) Plant Y and organism Z had to compete for food.
- (4) The presence of organism Z supported the growth of plant Y

11. The diagram shows trays A and B containing the same amount of identical soil. There are plants growing in tray A but not tray B. 200ml of water was poured into each tray and the water and soil flowing out of the tray were collected in the funnel and cylinder respectively.

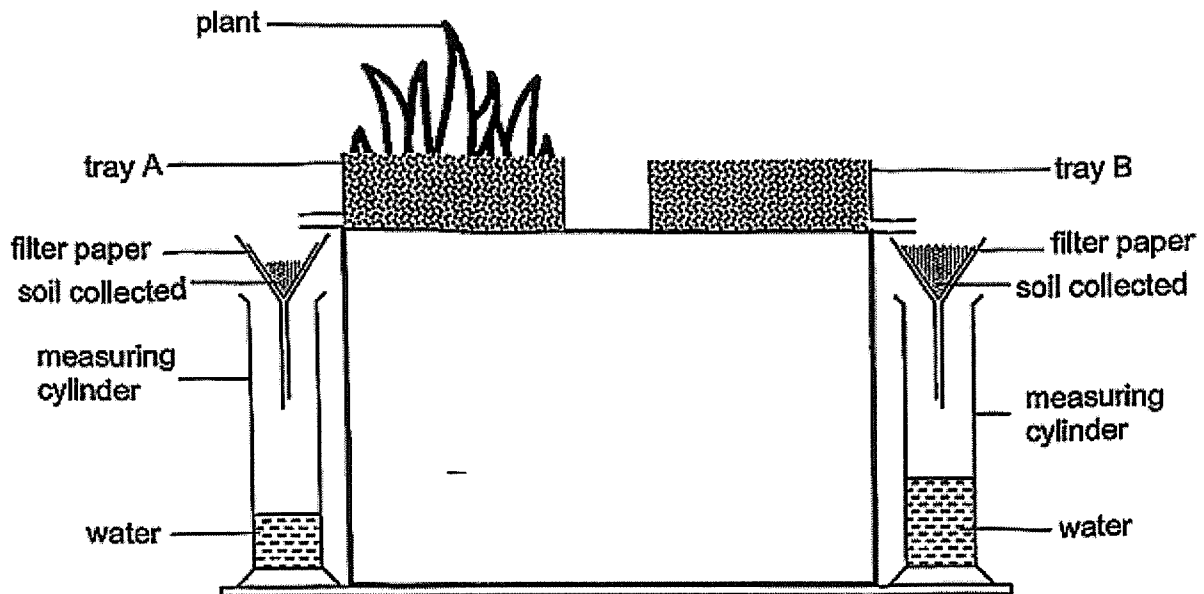

The amount of soil collected in the filter funnel was measured and recorded in the table below.

	Tray A	Tray B
Amount of soil collected (g)	33	105

Based on the information, which of the following is/are correct?

- A The roots of the plant held the soil particles tightly packed together.
- B The soil with the plant growing on it had more air spaces than the soil without the plant.
- C The soil with the plant growing holds a greater amount of water than the soil without the plant growing.

- (1) A only
- (2) C only
- (3) A and C only
- (4) A, B and C

12. The number of organisms found in a nature park are recorded in the table.

Organism	Number of organisms
Tree	2
Spider	3
Butterfly	5
Caterpillar	3
Squirrel	3
Staghorn Fern	2

Based on the information provided, which of the following statements is correct?

- (1) There is one producer.
 - (2) There are two consumers.
 - (3) There are five populations of organisms.
 - (4) There are five communities of organisms.
13. The food web shows the feeding relationship of some organisms in a forest.



The diagram below shows the changes in the appearance of a leaf in the forest over a week.

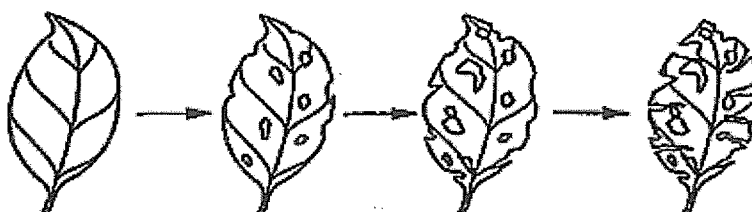

Which organism(s) is/are most likely to cause these changes?

- (1) N only
- (2) P only
- (3) N and O only
- (4) P, R and Q only

14. The diagram shows two different organisms, A and B. Organism A stings other animals but not organism B.



Organism A

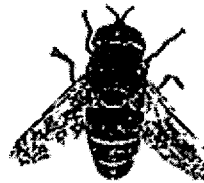

Organism B

Which of the following best explains how looking like organism A helps organism B in its survival?

- (1) Organism A will protect organism B.
 - (2) Organism B can feed on the nectar of flowers.
 - (3) Less of organisms B are hunted by its predators as it resembles organism A.
 - (4) Predators of organism B will have more food as organism A can be another source of food.
15. The table shows the increase in the average global temperature every ten years from 1960 to 2020.

Increase in average global temperature ($^{\circ}\text{C}$)

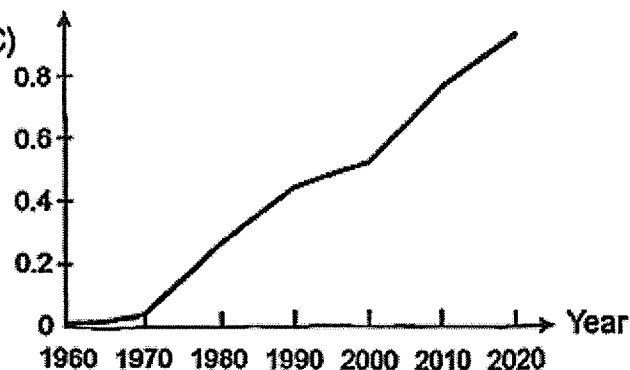

Based on the graph, which of the following is not a possible cause of the increase in the average global temperature?

- (1) Increased rate of deforestation
- (2) Increased number of cyclists on the roads
- (3) Increased burning of rubbish in incinerators
- (4) Increased amount of carbon dioxide released by cars and factories

16. Sam wanted to investigate how the degree of transparency of water from the different parts of a river affected the rate of photosynthesis. He collected equal amounts of water samples from three different parts of the river and labelled them W, X, and Y.

The experimental set-up is shown in the diagram. He prepared three set-ups, each containing the different water samples and identical number of similar water plants. He placed the set-ups in three enclosed cubicles in the science laboratory.

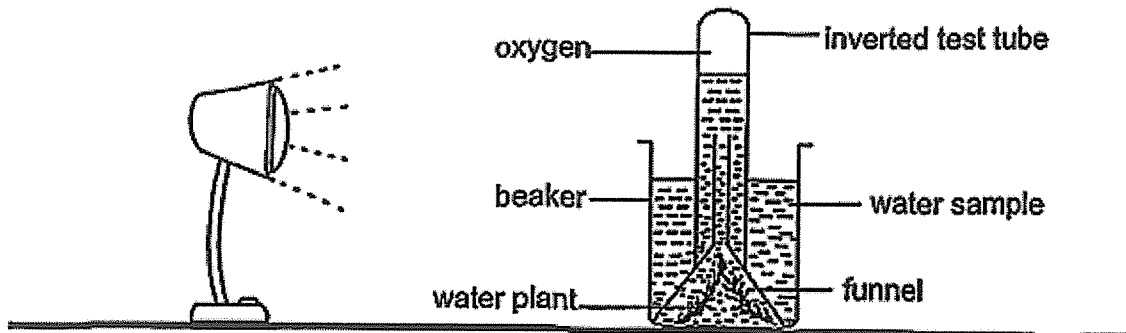

He measured the amount of oxygen produced by the water plants and recorded the results in a table over three hours.

Water sample	Amount of oxygen collected (cm ³)
W	100
X	60
Y	0

Based on the results, he made the following statements.

- A The water sample W was collected from the clearest part of the river.
- B The water plants in W, X and Y all photosynthesised but at different rates.
- C The rate of photosynthesis of the water plants was affected by the amount of light received by each plant.
- D The degree of transparency of water has no effect on the rate of photosynthesis of the water plants.

Which of the following is correct?

- (1) A and C only
- (2) A and D only
- (3) B and C only
- (4) A, B, C and D

17. The table shows the properties of some objects.
A tick (✓) represents the presence of the property in the object.

Properties Objects	Waterproof	Strong	Flexible	Can be made into a magnet
Aluminium foil				
Iron rod				
Paper plate				
Glass cup				

Which of the following objects were matched to their properties correctly?

- (1) Iron rod and paper plate
 - (2) Paper plate and glass cup
 - (3) Aluminium foil and iron rod
 - (4) Glass cup and aluminium foil
18. Study the flowchart.

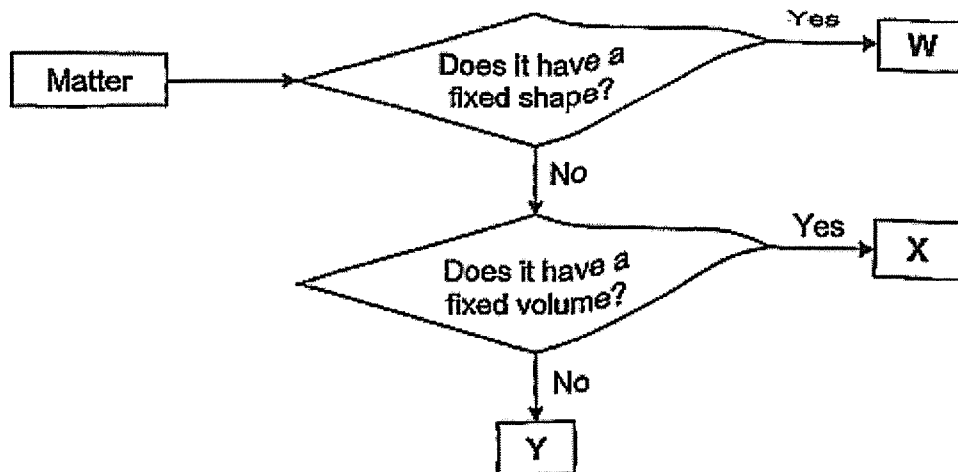

Based on the information, which of the following identify W, X and Y correctly?

	W	X	Y
(1)	Oxygen	Oil	Sand
(2)	Sand	Oxygen	Rice
(3)	Rice	Water	Oxygen
(4)	Water	Sand	Oxygen

19. Daniel prepared a set-up to measure the change in the volume of gases in a test tube containing a grasshopper. Substance M was used to absorb carbon dioxide from the air in the test tube. It was separated from the grasshopper by a wire gauze. Daniel observed the movement of the drop of red ink for thirty minutes.

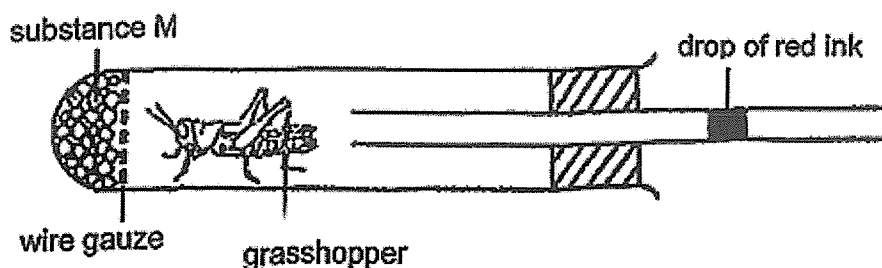

Which of the following describes the movement of the drop of red ink over thirty minutes and its correct corresponding explanation?

	Movement of ink	Explanation
(1)	Towards the grasshopper	There <u>is</u> more carbon dioxide in the test tube.
(2)	Towards the grasshopper	There is less oxygen in the test tube.
(3)	Away from the grasshopper	There is more oxygen in the test tube.
(4)	Away from the grasshopper	There is less carbon dioxide in the test tube.

20. Alice removed the freshly baked cookies from the oven and placed them on a plastic tray. After some time, she realised that only the bottom of the cookies were damp.

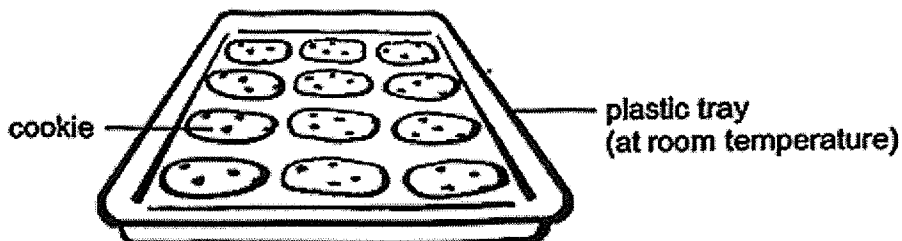

Which of the following explains why the bottom of the cookies on the tray were damp after some time?

- (1) The water vapour from the warm cookies gained heat from the plastic tray and evaporated.
 - (2) The water vapour from the warm cookies lost heat to the plastic tray and condensed.
 - (3) The water vapour from the warm cookies gain heat from the surrounding air and condensed.
 - (4) The water vapour from the surrounding air lost heat to the plastic tray and evaporated.
21. An electrical circuit with three bulbs B1, B2 and B3, and two switches S1 and S2 are connected as shown.

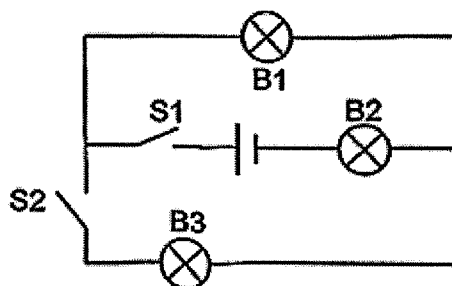

Which of the following options is correct?

	Switches		Do the bulbs light up?		
	S1	S2	B1	B2	B3
(1)	Open	Closed	No	Yes	No
(2)	Closed	Closed	No	Yes	Yes
(3)	Closed	Open	Yes	No	Yes
(4)	Closed	Open	Yes	Yes	No

22. Sally used some wires, three batteries, three bulbs, a switch, a cardboard and a metal paper clip to construct an electrical circuit. When she closed the switch of the electrical circuit, none of the bulbs lit up.

Which one of the following circuits was constructed by Sally?

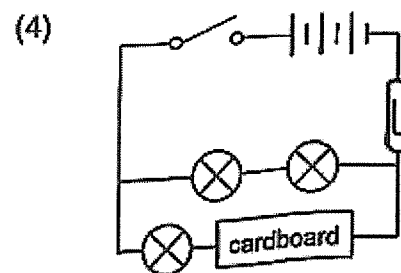
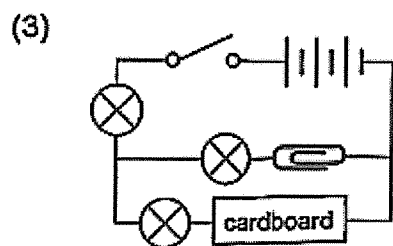
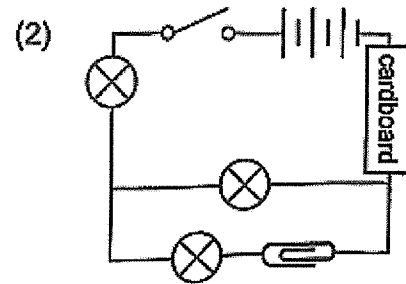
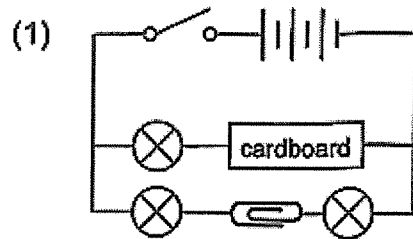

23. The opposite ends of bar P was labelled X and Y. The ends were brought close to the North pole of a magnet as shown in the diagram, one at a time.

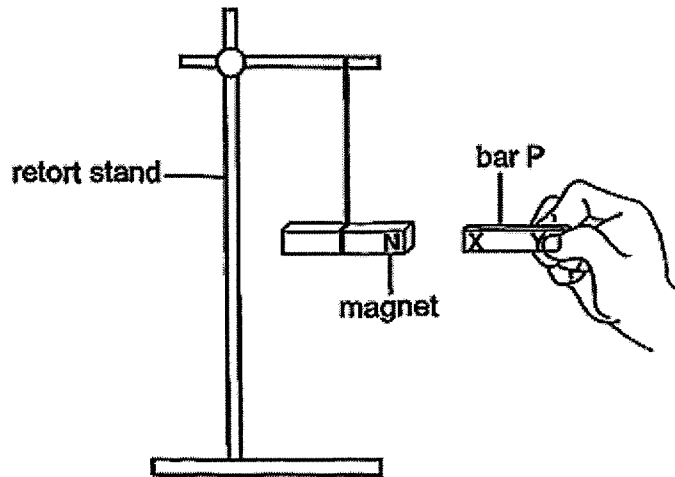

The experiment was repeated with both ends of bars Q and R.

The following table shows the interactions between the bars and the magnet.

Bar	Pole of the bar that is facing the magnet	Interactions observed		
		Attraction	Repulsion	No interaction
P	X			
	Y			
Q	X			
	Y			
R	X			
	Y			

What materials were the bars, P, Q and R, most likely made of?

	P	Q	R
(1)	Steel	Plastic	Wood
(2)	Iron	Silver	Plastic
(3)	Silver	Cobalt	Wood
(4)	Iron	Steel	Glass

24. Aini tossed her graduation hat into the air as shown in the diagram.

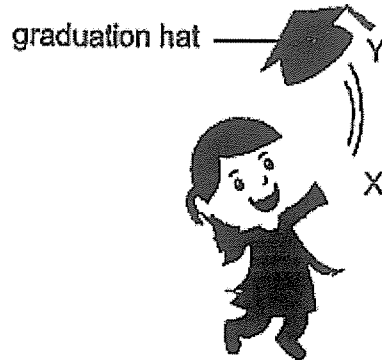

Which of the following line graph shows the amount of gravitational force acting on the graduation hat as it was being tossed into the air, from height X to Y?

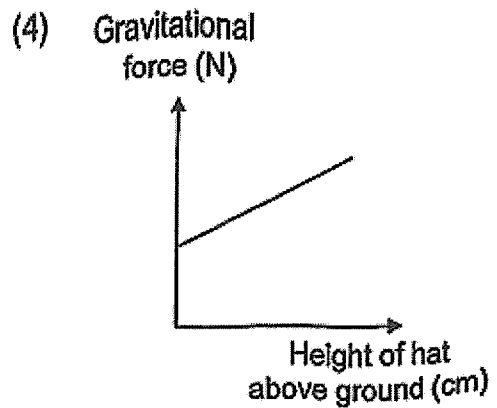
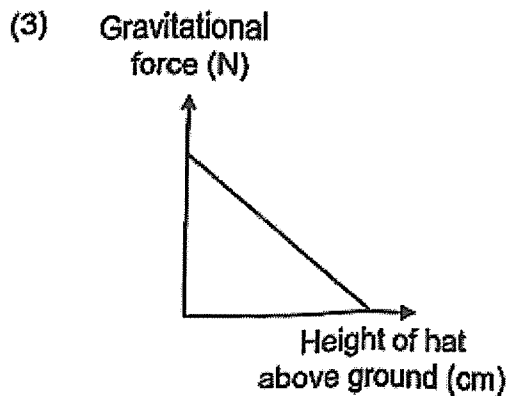
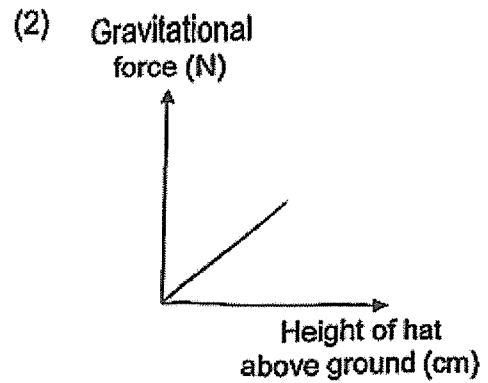
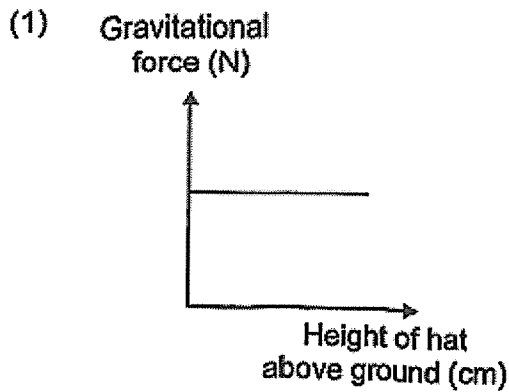

25. Julia walks with bouncy spring shoes on. Each of her feet moves up and down, as shown by the arrows in the diagram below, from height A to B, and then from B to A repeatedly as she walks. The spring is compressed with each step she takes as shown.

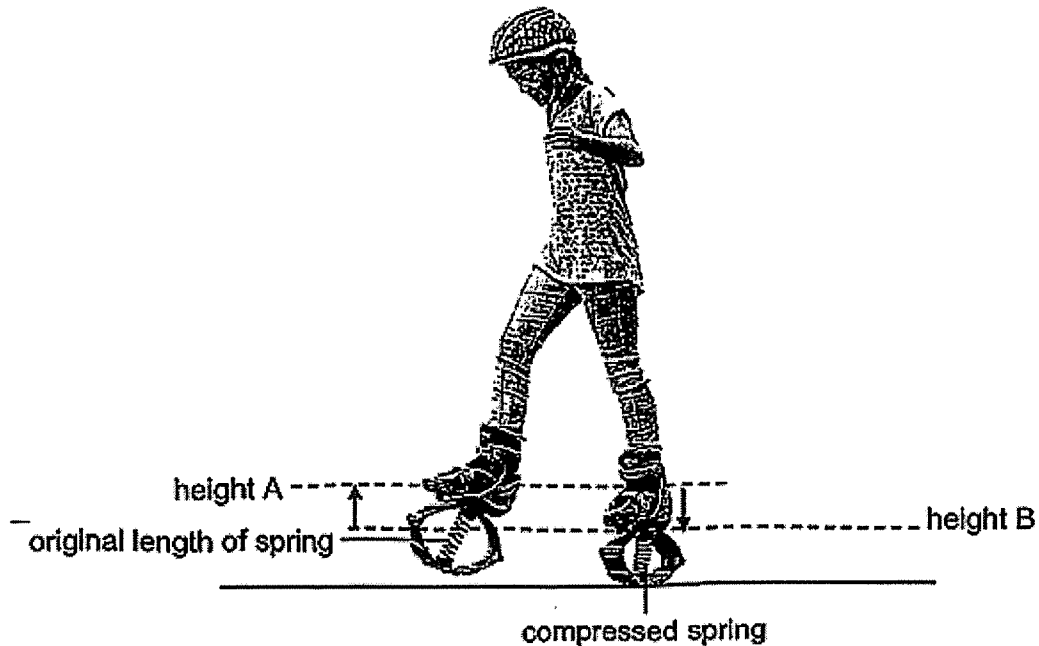

Based on the information above, which of the following statement(s) is/are true?

- A More gravitational force is acting on Julia's shoes at height A than B.
- B Frictional force is acting on Julia's bouncy spring shoes as she walks.
- C Elastic spring force acting on Julia's foot is increasing as it moves from height A to B.
- D At height B, elastic spring force is acting on Julia's foot in the same direction of her weight.

- (1) B only
- (2) A and D only
- (3) B and C only
- (4) A, C and D only

26. The diagram shows four points, P, Q, R, and S, where light sources can be placed directly above two identical wooden tubes, X and Y.

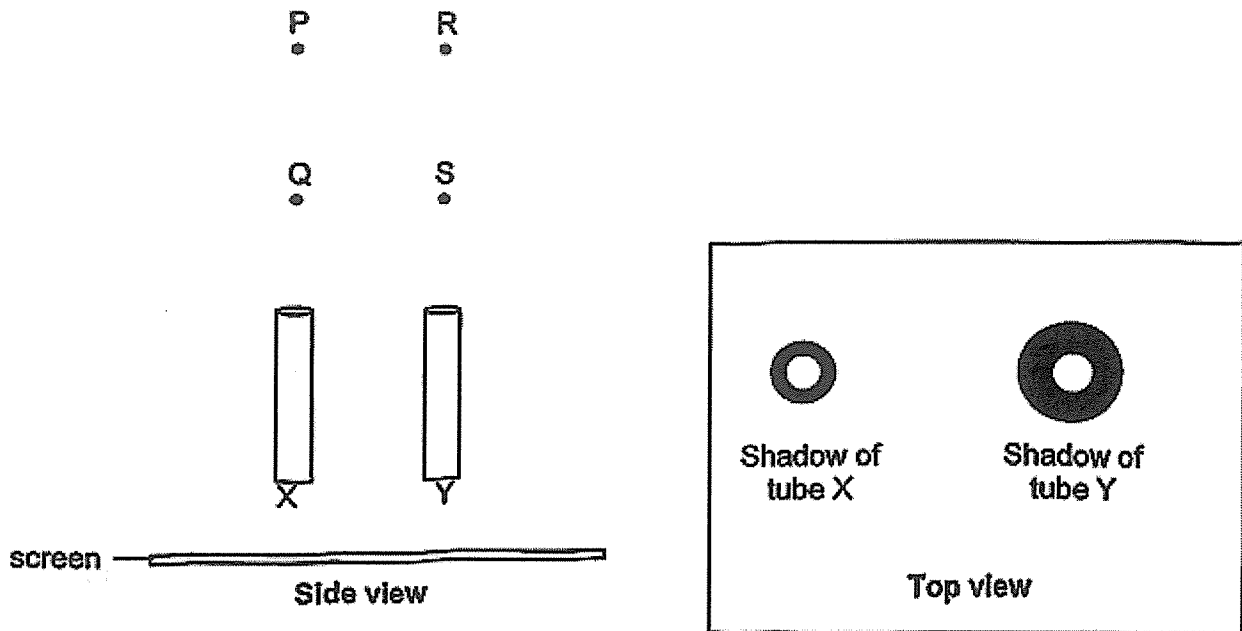

At which two points, P, Q, R and S, should the light sources be placed, for the shadows of tubes X and Y to be cast as shown, when viewed from the top?

- (1) P and R
- (2) P and S
- (3) Q and R
- (4) Q and S

27. Sara placed two pieces of cloth at 60°C , made of materials X and Y, on identical flasks, A and B, at the same time. The glass tubes in the flasks were placed in two identical containers, with 500ml of water at 28°C .

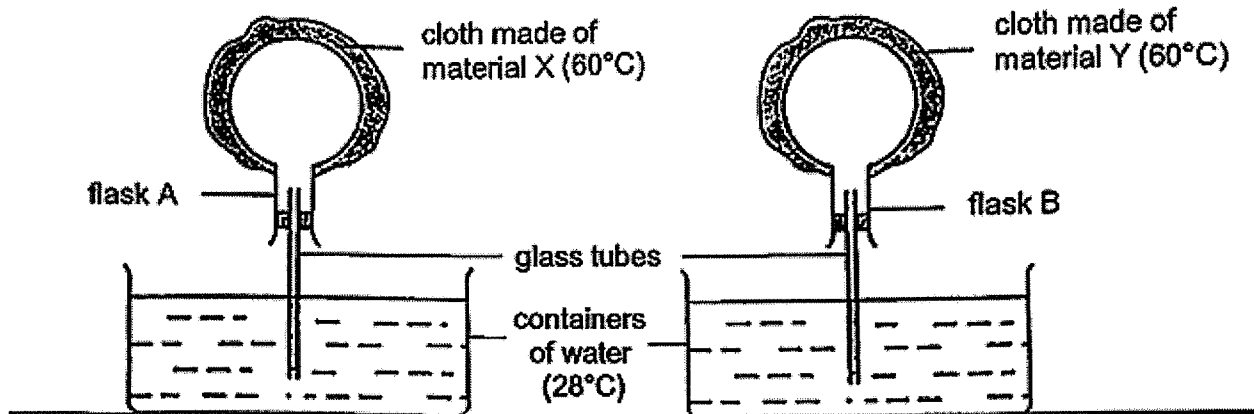

After two minutes, Sara observed the following.

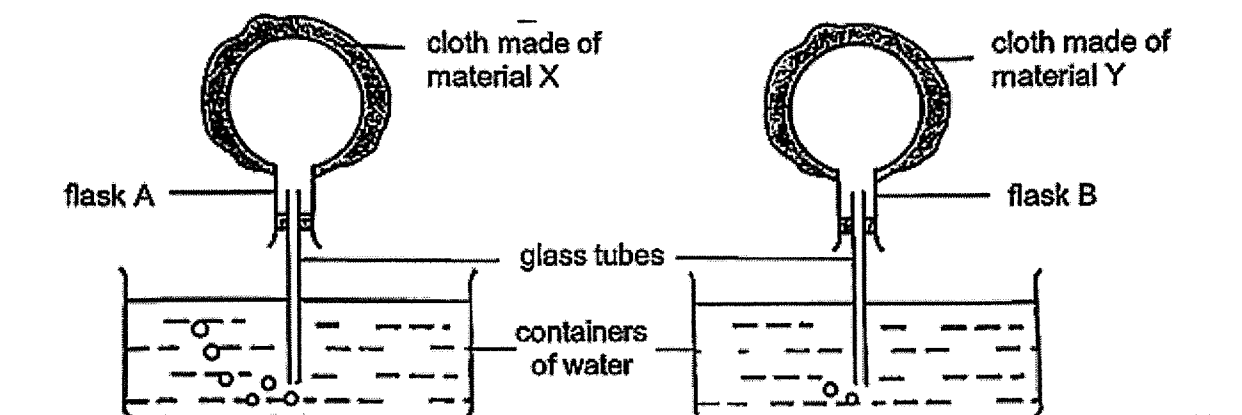

Which of the following materials, X or Y, is more suitable to make a blanket to keep a person warm in cold weather and to make into curtains that keeps a room cool in hot weather?

	Material to make a blanket to keep a person warm	Material to make curtains to keep a room cool
(1)	X	X
(2)	Y	Y
(3)	X	Y
(4)	Y	X

28. Zul wanted to find out how the design of the blades of a wind turbine affects the amount of electrical energy it can generate. He used three different wind turbines, P, Q and R, for his experiment. He placed the three turbines in the same field.

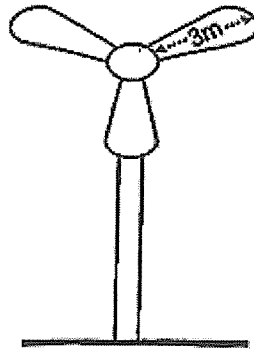

After a few days, he recorded the results in the table.

Wind turbine	Number of blades	Length of blades (m)	Amount of electrical energy generated (kW)
P	3	3	5000
Q	3	10	55000
R	3	5	14000

Based on the results, which of the conclusion(s) is/are correct?

- A As the length of blades decreases, the amount of electrical energy generated increases.
- B As the length of blades increases, the amount of electrical energy generated increases.
- C As the amount of electrical energy generated decreases, the length of the blades decreases.

- (1) A only
- (2) B only
- (3) B and C only
- (4) A, B and C

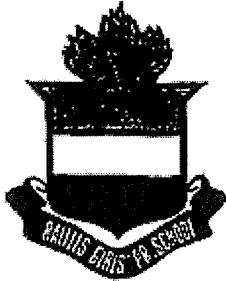

**RAFFLES GIRLS' PRIMARY SCHOOL
PRELIMINARY EXAMINATION
PRIMARY SIX
2023**

**SCIENCE
(BOOKLET B)**

Name: _____ ()

Date : 28 August 2023

Class: P6 _____

Total Time : 1h 45min

INSTRUCTIONS TO CANDIDATES

1. Write your name, class and index number in the spaces provided above.
2. Do not turn over this page until you are told to do so.
3. Follow all instructions carefully.
4. Answer all questions.
5. Use a dark blue or black ballpoint pen to write your answers in the space provided for each question.
6. Do not use correction fluid / tape or highlighters.

Score	44
-------	----

29. The classification chart shows how animals are being grouped. Each animal is represented by a letter, D, E, F, G or H.

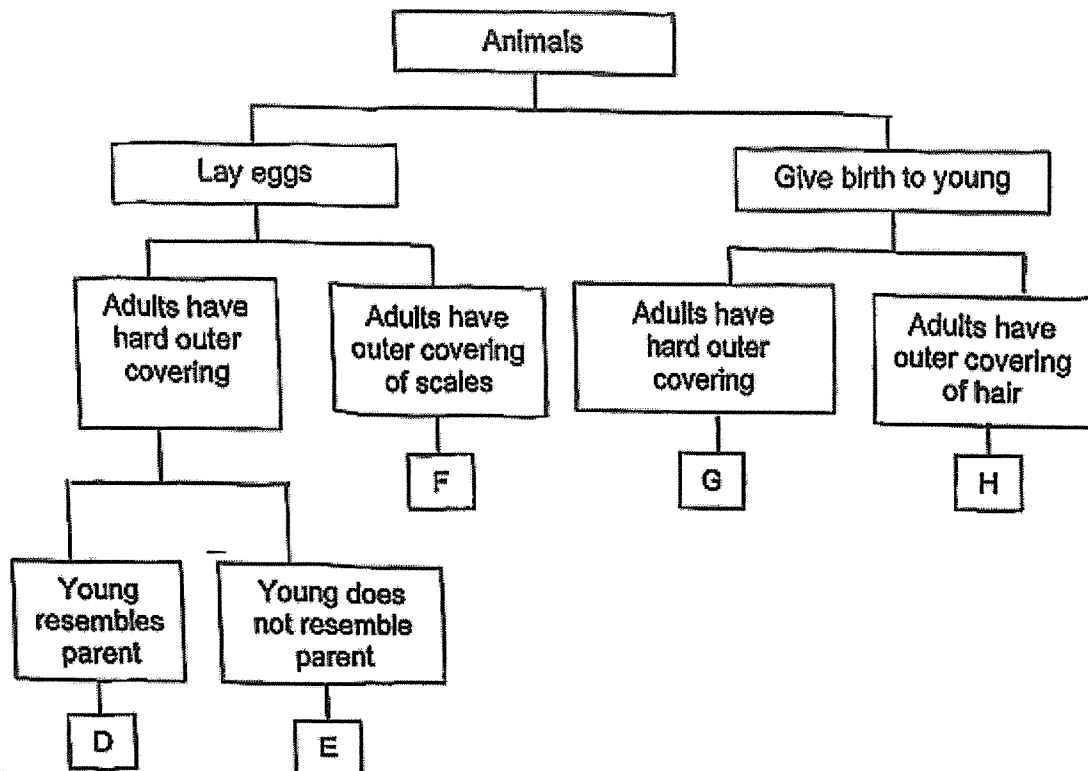

Based on the information above, answer the following questions.

- (a) Which letter, D, E, F, G or H, represents a beetle? [1]

- (b) Which animal(s), D, E, F, G and/or H is/are mammals? [1]

- (c) State a difference between animals F and H. [1]

Score	3
-------	---

30. The diagram shows Process X that takes place in flowers.

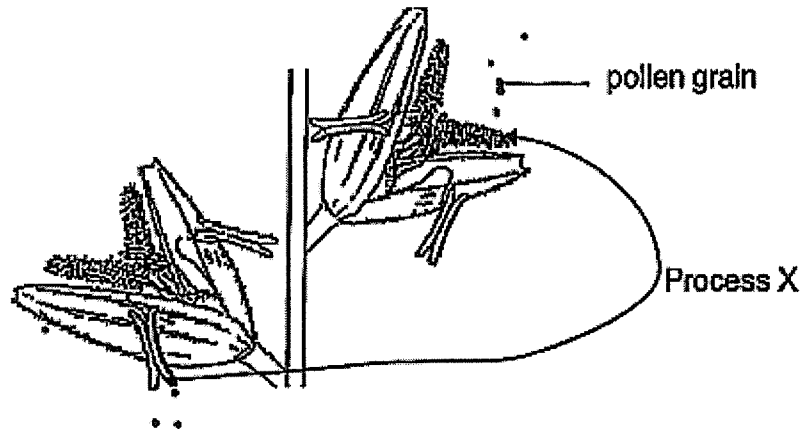

(a) State the process shown in the diagram above. [1]

The diagram below shows flower R. The male parts of flower R are hanging out from the flower.

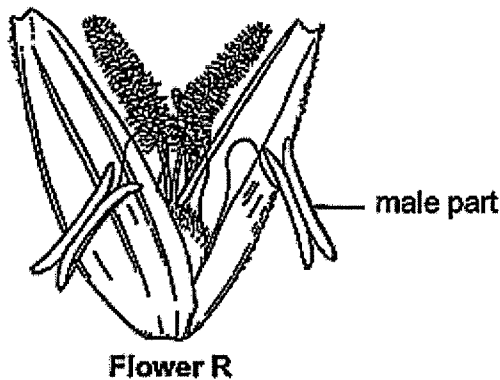

(b) How does having the male part hanging out of the flower help flower R to reproduce? [1]

Continue on Pg 25

Score	2
-------	---

Continued from Pg 24

The diagrams show the parts of a flowering plant and the male and female human reproductive systems.

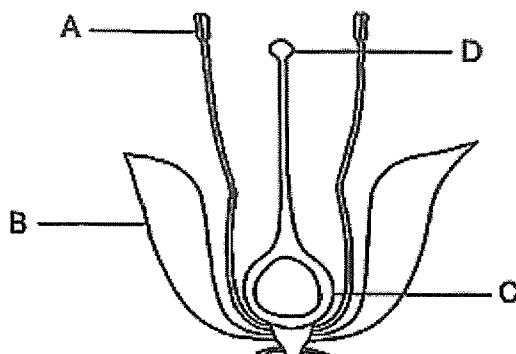

Reproductive system of a flower

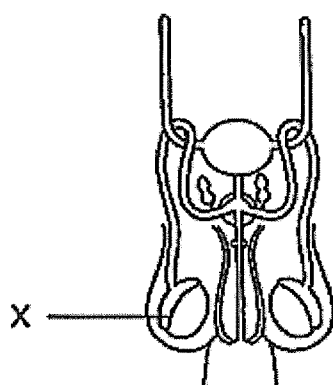

Male Reproductive system

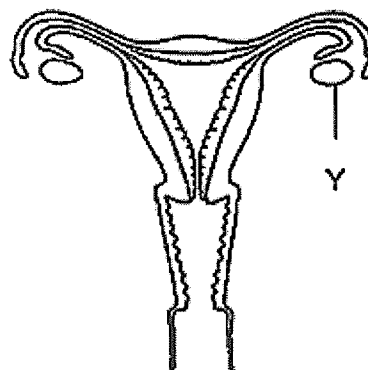

Female Reproductive system

(c) Read the following statements. Put a tick (✓) in the correct box to indicate if the statement is true or false. [2]

Statement	True	False
Parts A and X produce the male reproductive cells.		
Fertilisation occurs at parts C and Y.		

Score	2
-------	---

31. (a) State all the parts of the human digestive system that produce digestive juices. [1]

A student wanted to find out if the amount of digestive juice will affect the rate of digestion. She prepared two set-ups containing water and different volume of digestive juice as shown in the diagram.

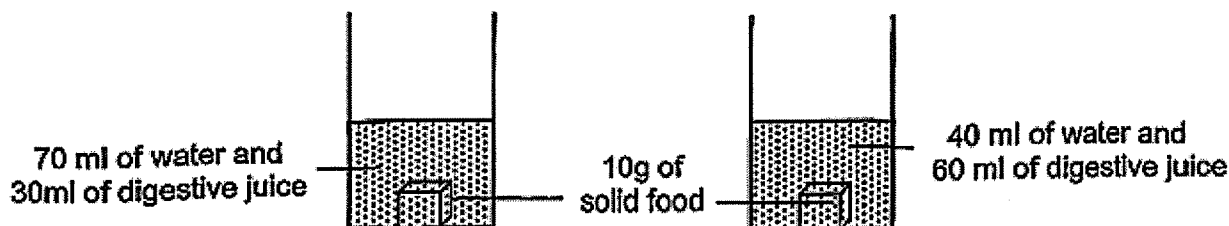

- (b) The teacher told the student to prepare a third set-up with another 10g of identical food but with 100ml of water only.

Explain the purpose of the third set-up. [1]

- (c) State two other variables that must be kept constant to ensure a fair test. [1]

- (i) _____
- (ii) _____

Score	3
-------	---

32. Organism X feeds on dead matter and reproduces by spores. It infects ants in order to reproduce. When the spores land on ants, it grows and enters the ants' bodies, killing them after a few days. Organism X thrives in moist conditions.



- (a) The ants are a source of food for other organisms such as spiders. Describe how the presence of organisms X could affect the population of spiders. [2]

The amount of rainfall in a rainforest is shown in the table.

Month	Amount of rainfall (mm)
June	50
July	38
August	15
September	20
October	43
November	64
December	60

- (b) Based on the information, in which month would the population of ants likely to be the largest in the rainforest? Explain your answer. [2]

Score	4
-------	---

33. Ana wanted to investigate if the temperature of the surroundings affects the melting of ice. The diagram shows the experimental set-up.

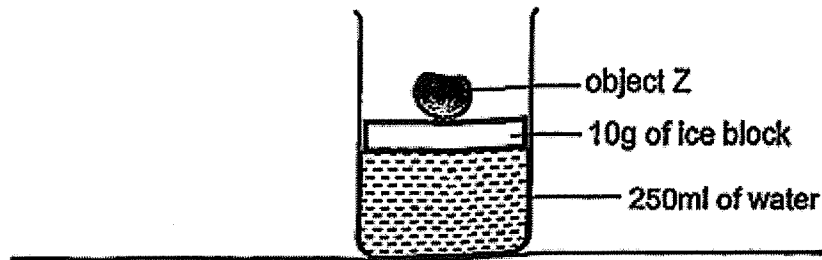

Identical set-ups, A, B and C, were set up in different locations. The initial temperatures of the water in set-ups A, B and C were the same. She measured the time taken for object Z to drop to the bottom of each beaker and recorded it in table.

Set-up	Temperature of the surroundings ($^{\circ}\text{C}$)	Time taken for object Z to drop to the bottom (min)
A	4	20
B	20	12
C	45	5

- (a) What is the relationship between the temperature of the surroundings and the time taken for object Z to drop to the bottom? [1]

Continue on Pg 29

Score	1
-------	---

Continued from Pg 28

Global warming causes the amount of ice on the surface of sea water to decrease.

Seals are mammals which feed on fish and other animals in the sea. They can hold their breath underwater for about fifteen minutes. Then, they need to come up for air and rest on the surface of ice.

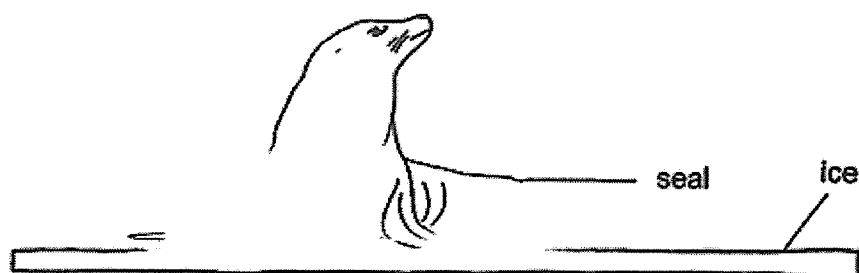

- (b) Based on the results in (a) and the information given, describe how global warming affects the survival of the seals. [2]

Score	2
-------	---

34. Siva placed identical cups A and B onto a balance. He then, put some glass balls and iron balls, of identical size, into cups A and B respectively.

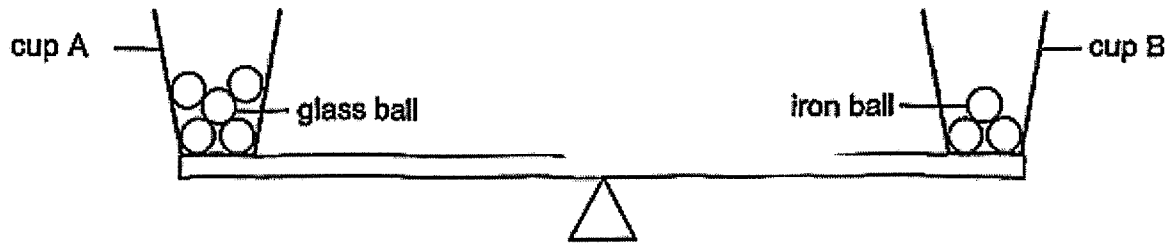

- (a) Based on the diagram, is the mass of 1 glass ball less than, more than, or the same as 1 iron ball? [1]

The Iron balls are heated and placed back into cup B on the same balance.

- (b) A student predicted that the side of the balance with cup B containing the heated iron balls will tilt downwards. Do you agree with her? Give a reason for your answer. [1]

- (c) Which of the cups, A or B, shown in the diagram above, requires more water to be filled completely to the brim? Explain your answer. [1]

Score	3
-------	---

35. Sam had been experiencing weeks of hot weather. Then it rained heavily and there were puddles of water everywhere in the surrounding. After some time, the puddles of water disappeared and he observed that the surrounding air became cooler.

(a) Explain his observation. [2]

Sam wore a special cooling vest to keep himself cool while hiking up the hill on a hot day with a surrounding temperature of 33°C . In preparation for the hike, he immersed the vest in the water. After the absorbent layer soaked up the water, he squeezed out the excess water before wearing the vest.

The structure of the vest is shown in the diagram.

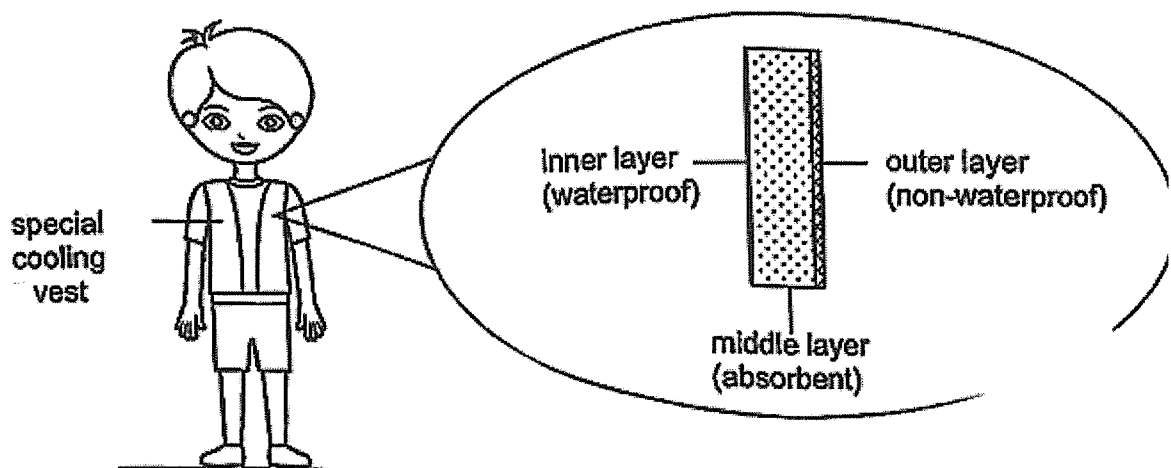

(b) Explain how wearing the special cooling vest helped to keep him cool during the hike on a hot day. [1]

Score	3
-------	---

P6 Science Prelim 2023

36. The diagram shows an electrical cooking stove with two heating plates, A and B, which can be switched on and off independently.

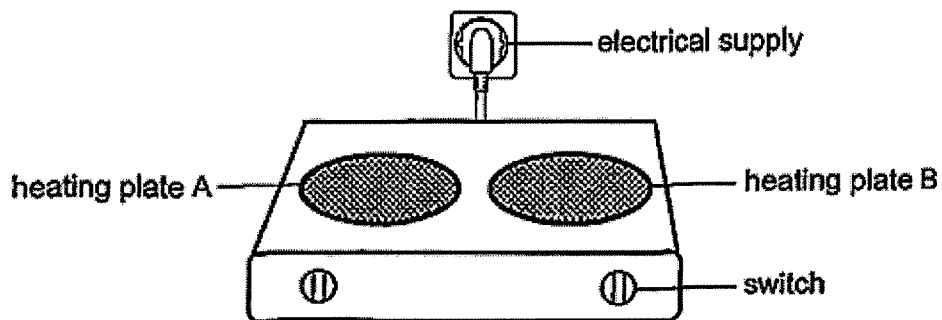

Complete the circuit below to show how the two heating plates can be controlled independently with heating plate A turned on and heating plate B turned off. [3]

Note: Do not change the positions of any of the circuit parts given below.

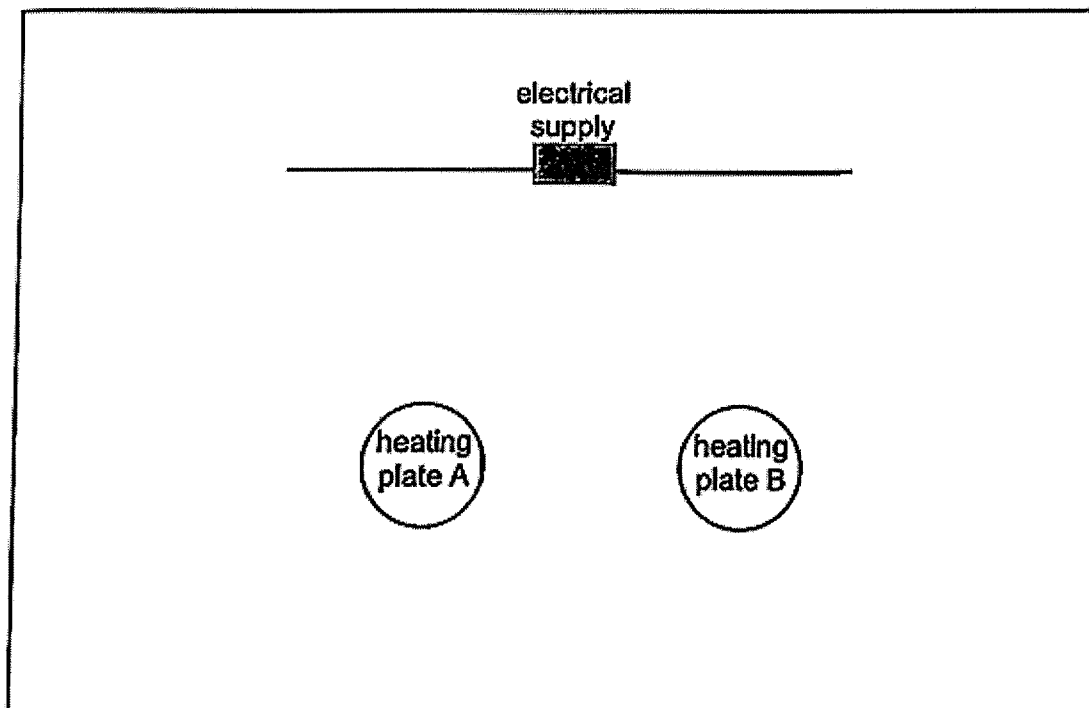

Score	3
-------	---

37. Ling hung a steel chain over the edge of a table as shown in the diagram.

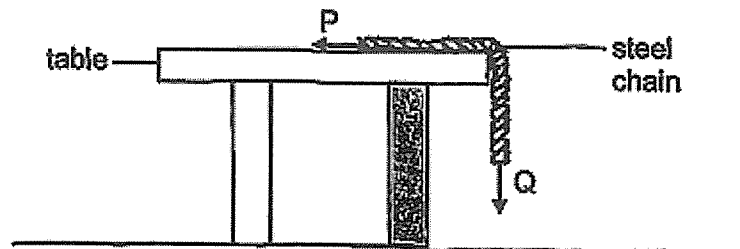

(a) Identify the forces acting on the steel chain represented by arrows P and Q. [2]

(i) P: _____

(ii) Q: _____

Ling observed that the steel chain did not slide off the table. She then placed an object A on the ground directly under the dangling chain as shown below. She observed that the chain slid down the table immediately.

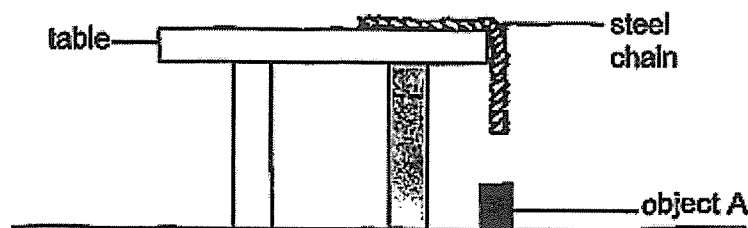

(b) What could object A be? [1]

(c) Explain, in terms of forces, why the chain slid off the table immediately when object A was under it? [1]

Score	4
-------	---

38. A magnetic window cleaner device is used to clean the inner and outer sides of a glass window as shown.

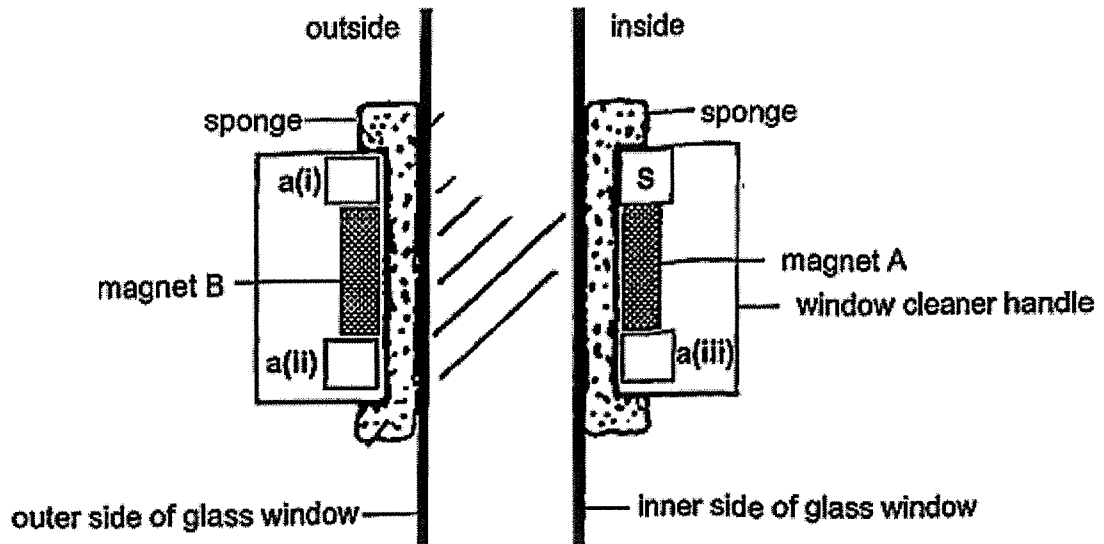

The sponges are dipped in soapy water, then excess water is squeezed out from the sponges. The device is then attached to the glass window using two strong magnets, A and B, as shown above.

- (a) Label the remaining three poles of magnets A and B in the boxes provided in the diagram above. The S-pole of magnet A has already been labelled. [1]

Tom dipped this device in soapy water but did not squeeze out the excess soapy water before attaching the device to his glass window. He observed that each time he tried to move the device to start cleaning, the sponges would slide down the glass window and drop to the ground.

- (b) Explain, in terms of forces, why the device slid down the glass window and dropped to the ground. [2]

Score	3
-------	---

39. Joe wanted to find out how the position of a metal cone can affect the shape and size of the shadows casted on the screen, in a dark room. Three identical metal cones are positioned differently and placed at varying distances away from identical lamps as shown.

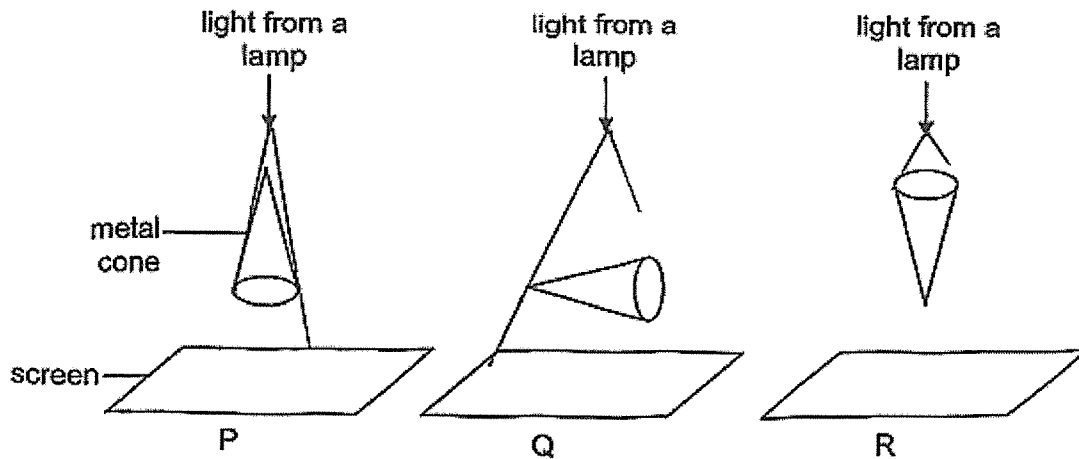

- (a) Draw the shadow of the cone cast on the screens, P, Q and R, correctly in terms of their shapes and relative sizes. [2]

Screen P	Screen Q	Screen R

- (b) State the colour of the shadow of the metal cone, cast on the screen, when a purple light was shone on it? [1]

Score	3
-------	---

40. Sam placed his left hand on a board made of material X and his right hand on a board made of material Y. His left hand felt colder than his right hand. He then placed two similar pieces of frozen meat taken from the freezer on the boards made of materials X and Y respectively, as shown in the diagram. The two boards are of the same size and thickness at room temperature of 30°C .

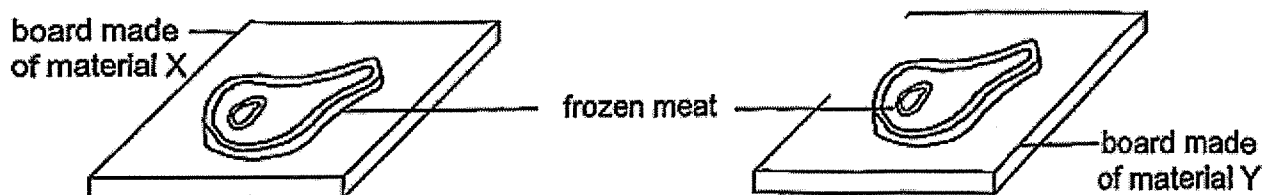

- (a) On which board, X or Y, would the meat defrost faster? Explain your answer. [2]

The graph below shows the change in the temperature of the board made of material X, taken every ten minutes, for forty minutes.

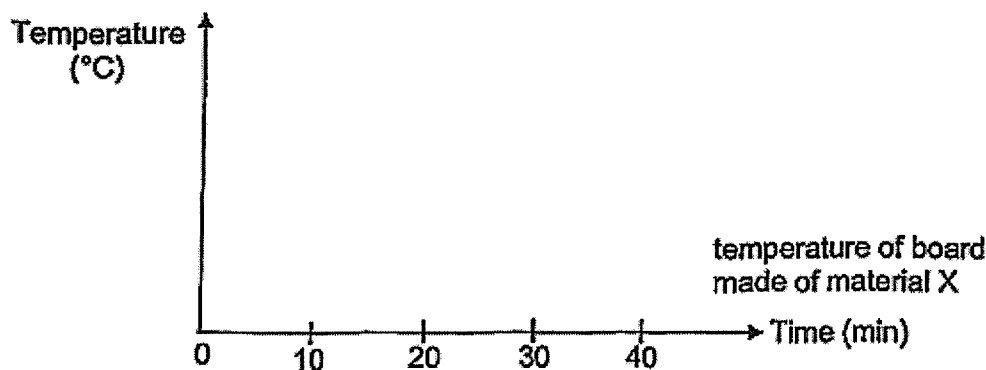

- (b) Draw a line on the graph to show the change in temperature of the board made of material Y during the same forty minutes. [1]
- (c) Which material, X or Y, should Sam use to make a container to keep food warmer for longer time? Give a reason for your answer. [1]

Score	4
-------	---

41. The brand of shoes called 'Walk & Charge' can generate and store energy with every step that the wearer takes. With each step, the wearer's foot will press down on the pressure sensor to generate energy which can be stored. This stored energy can then be used to charge devices like handphnes through the USB charging outlet as shown in the diagram.

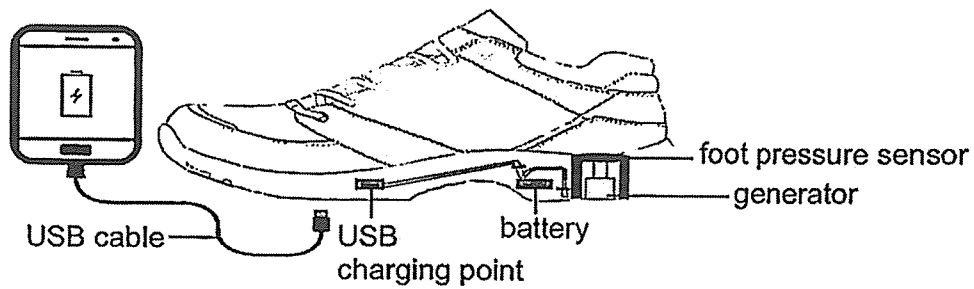

- (a) State the energy conversion to charge the handphne. [1]

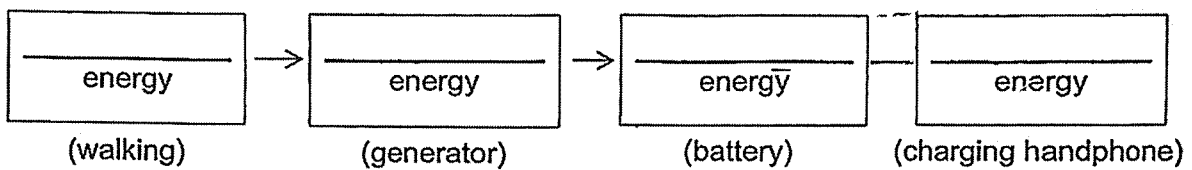

- (b) How does using the 'Walk & Charge' shoes as a source of energy benefit the Environment?

The charging ability of the 'Walk & Charge' shoes is then improved by adding more foot pressure sensors as shown in the diagram.



- (c) Explain, in terms of energy, why this has improved its charging ability.

End of paper

Score	4
-------	---

SCHOOL : Raffles Girls' PRIMARY SCHOOL
 LEVEL : PRIMARY 6
 SUBJECT : SCIENCE
 TERM : Prelim 2023

SECTION A

Q 1	Q2	Q3	Q4	Q5	Q6	Q7	Q8	Q9	Q10
2	1	1	3	2	4	2	2	3	1
Q 11	Q12	Q13	Q14	Q15	Q16	Q17	Q18	Q19	Q20
3	3	3	3	2	1	1	3	2	2
Q 21	Q22	Q23	Q24	Q25	Q26	Q27	Q28		
4	2	4	1	3	2	2	2		

SECTION B

Q29)	<p>a) Letter E represents a beetle.</p> <p>b) Animal H is a mammal.</p> <p>c) Animal F lays eggs but animal H gives birth to young.</p>									
Q30)	<p>a) The process is pollination.</p> <p>b) It increases the chances or mind carrying the pollen grains from anther to the stigma of another flower of the same species.</p> <table border="1" style="margin-left: auto; margin-right: auto;"> <thead> <tr> <th>Statement</th> <th>True</th> <th>False</th> </tr> </thead> <tbody> <tr> <td>Parts A and X produce the male reproductive cells.</td> <td style="text-align: center;">✓</td> <td></td> </tr> <tr> <td>Fertilisation occurs at parts C and Y.</td> <td></td> <td style="text-align: center;">✓</td> </tr> </tbody> </table> <p>c)</p>	Statement	True	False	Parts A and X produce the male reproductive cells.	✓		Fertilisation occurs at parts C and Y.		✓
Statement	True	False								
Parts A and X produce the male reproductive cells.	✓									
Fertilisation occurs at parts C and Y.		✓								
Q31)	<p>a) Mouth, Stomach and small intestine produce digestive juices.</p> <p>b) The purpose of the third set-up is to compare and confirm that the amount of digestive juice is the sole factor that affects the rate of digestion and not any other factor.</p>									

	<p>c) (i) the type of food (ii) the amount of exposed surface area of the solid food in contact with the digestive juices. (iii) the duration of the environment. (iv) size of food. (iiv) temperature of digestive juice.</p>
Q32)	<p>a) Must use the evidence in the question to clearly state the relationship between organism X, ants and the spiders. b) Month of August, E: It has lowest amount of rainfall which means it is the driest month. R: It could reduce the growth of organism X on the ants, hence, less ants will get killed.</p>
Q33)	<p>a) The higher the temperature of the surroundings, the shorter the time taken or the object Z to drop to the bottom. b) E: Global warming causes the temperature of the surroundings to increase. Hence, ice will melt faster and decrease in size. R: As a result, the seas will eventually have less ice left to rest on. This could lead to their drawing in the seal, leading to them drawing lead them die from exhaustion.</p>
Q34)	<p>a) 1 glass ball is less than 1 iron ball. b) I do not agree, the mass of the iron ball will stay the same even after being heated, so the balance will still be balanced. c) Cup B. There are fewer balls in cup B.</p>
Q35)	<p>a) The cooler water from puddles gained heat from the warmer surrounding air and evaporated, removing some heat from the environment. b) The cooler water in the absorbent layer of the vest gained heat from Sam's warmer body and evaporated through the non-waterproof layer thus learning heat from Sam's body and keeping him cool.</p>

Q36)

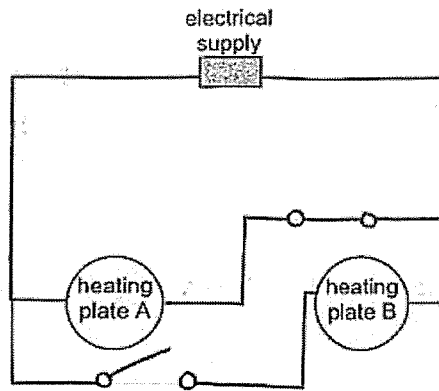

Q37)

- a) (i) Frictional force
(ii) Gravitational force
- b) Object A could be a magnet.
- c) The steel chain is attracted to object A. The amount of magnet force or attractational gravitational force acting on the steel chain is greater than the amount of frictional force acting between the steel chain and the table.

Q38)

a)

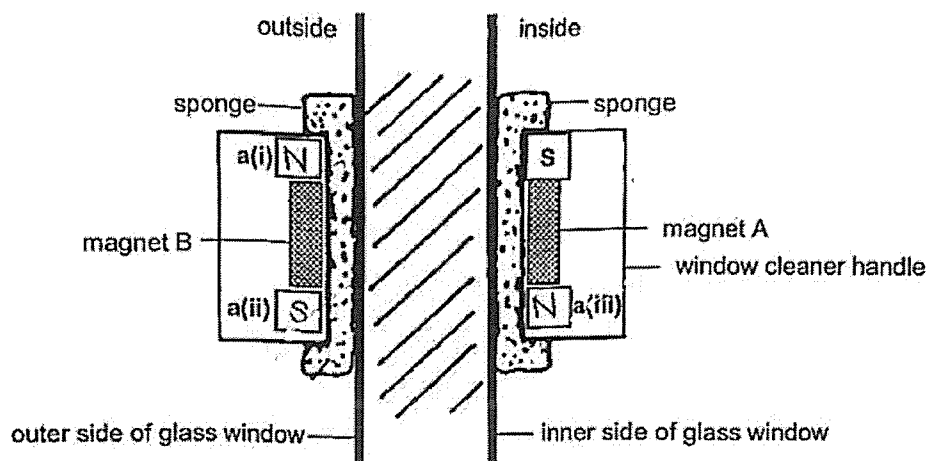

- b) The excess soapy water reduces frictional acting between the sponges and the glass window or with excess soapy water, gravitactic acting on the divide incenses. The amount of gravitational force acting on the device was greater than frictional force acting between the sponge and the glass window or the amount or gravitational force acting on the

device was greater than the magnetic force acting between the sponge and the glass window.

Q39)

a)

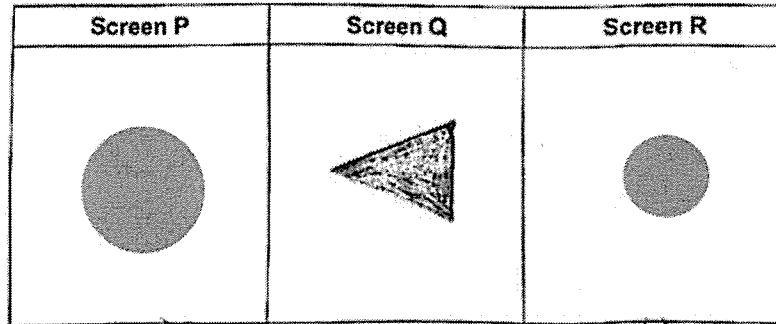

b) The colour of the shadow will be black.

Q40)

a) (i) The meat on board X will defrost faster.

-b)

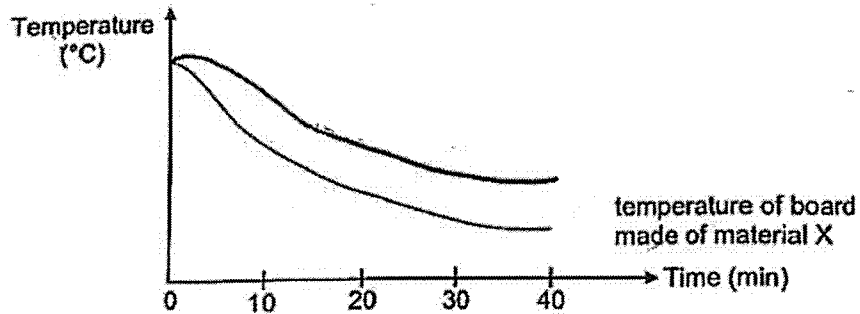

c) Material Y. Material Y is a poorer conductor of heat compared to material X. It will conduct heat from the food to the cooler surrounding at a slower rate, keeping food warmer for a longer time.

Q41)

a)

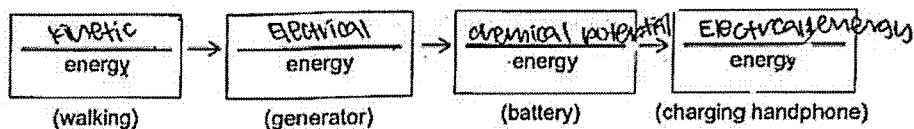

b) It is a renewable source of energy.

	<p>c) With more foot pressure sensors, more kinetic energy of the personal single shoe can be converted to more electrical energy in the generator can be converted to more chemical potential energy in the battery can be converted to more electrical energy in the charging handphone, thus invoicing its changing ability.</p>
--	--

