

Index No.

--	--	--	--	--	--	--

--

PEI CHUN PUBLIC SCHOOL
PRIMARY 6
PRELIMINARY EXAMINATION 2023

SCIENCE
(BOOKLET A)

Additional Materials: Optical Answer Sheet (OAS)

Total Time for Booklets A and B: 1 h 45 min

Name: _____ ()

Class: Primary 6 () _____

Date: 22 August 2023

Science Teacher: _____

INSTRUCTIONS TO CANDIDATES

1. Do not turn over this page until you are told to do so.
2. Follow all instructions carefully.
3. Answer all questions.
4. Shade your answers on the Optical Answer Sheet (OAS) provided.

Section A (28 × 2 marks)

For questions 1 to 28, choose the most suitable answer and shade its number (1, 2, 3 or 4) on the Optical Answer Sheet (OAS) provided.

1 Which one of the following organisms does **not** reproduce by spores?

(1)

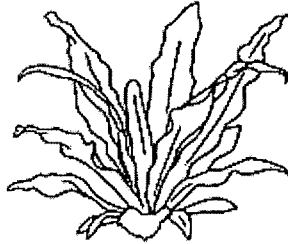

fern

(2)



mushroom

(3)



water lotus plant

(4)

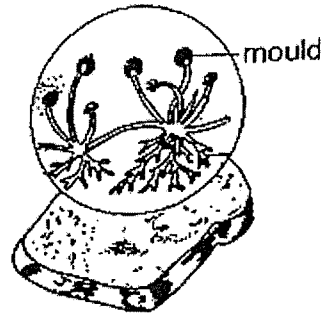

2 Nurul classified three animals as shown.

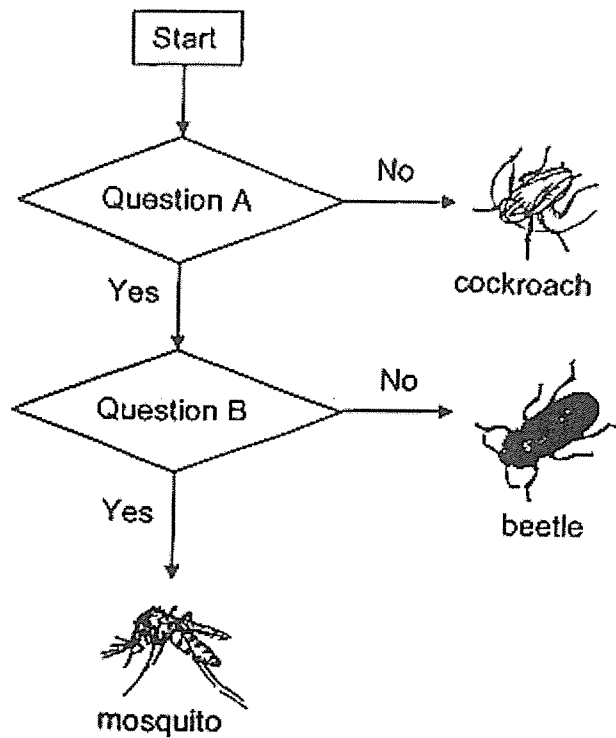

What are questions A and B?

	Question A	Question B
(1)	Does it have a 3-stage life cycle?	Does it lay eggs in water?
(2)	Does it have a 3-stage life cycle?	Does the young look like the adult?
(3)	Does it have a 4-stage life cycle?	Does it lay eggs in water?
(4)	Does it have a 4-stage life cycle?	Does the young look like the adult?

3 Which statement about the large intestine is correct?

- (1) Water is absorbed into the blood.
- (2) Digestive juices are added to the food.
- (3) It has the most amount of undigested food.
- (4) Some food is broken down into simpler substances.

- 4 The diagram shows how water and food flow through different parts, D, E, F and G, of a plant.

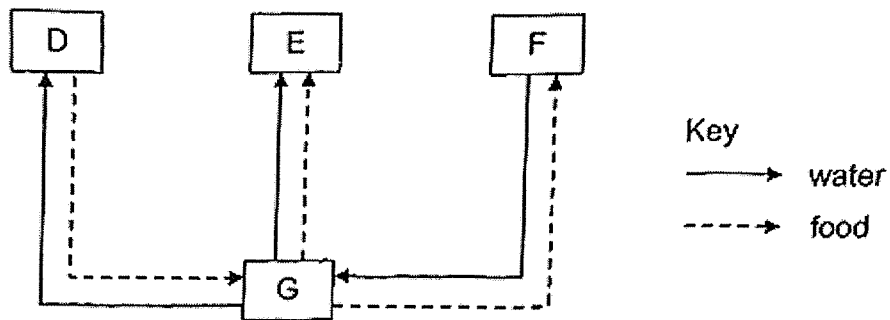

What do D, E and F represent?

	D	E	F
(1)	root	flower	leaf
(2)	leaf	stem	root
(3)	flower	root	stem
(4)	leaf	flower	root

- 5 The diagram shows a plant cell.

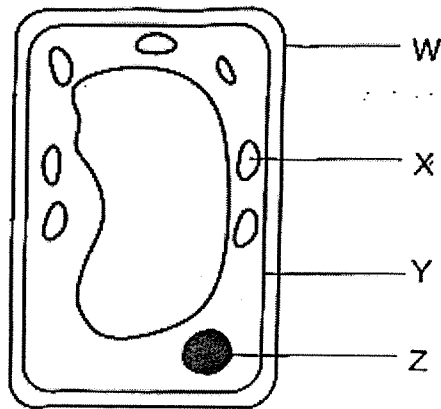

Which of the following correctly matches the parts of the cell to their functions?

	Give the cell its shape	Contains genetic information of the cell	Contains chlorophyll
(1)	W	Z	X
(2)	W	X	Z
(3)	Y	Z	X
(4)	Y	X	Z

- 6 Sami was crying when trapped in the lift for 30 minutes. There was no fresh air entering the lift.

Which statement is not correct?

- (1) Water is lost through breathing.
- (2) The amount of oxygen in the lift decreased.
- (3) Nitrogen produced by the body is released into the air.
- (4) All types of gases in the air enter Sami's respiratory system.

- 7 The diagram below shows a habitat with some living things.

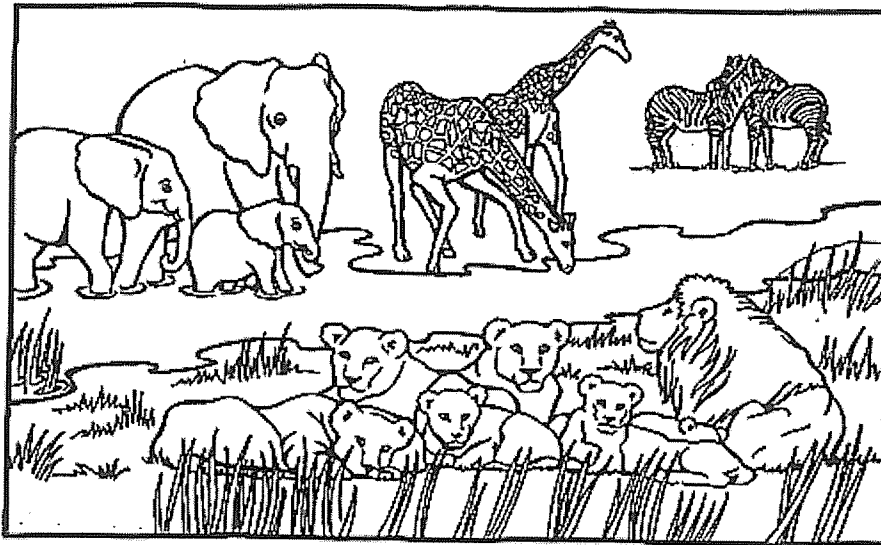

Based on the diagram shown, which of the following statements is correct?

- (1) The elephants form three populations.
- (2) There are five populations of producers.
- (3) There are four populations of consumers.
- (4) The lions and their young form one community

8 The diagram below shows how blood flows in certain parts of the body.

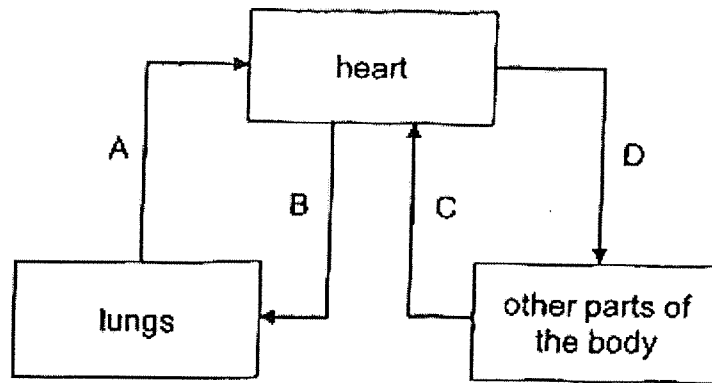

The same amount of blood was taken from A, B, C and D.

Which chart shows the correct comparison of the amount of oxygen in the blood samples?

(1) amount of oxygen

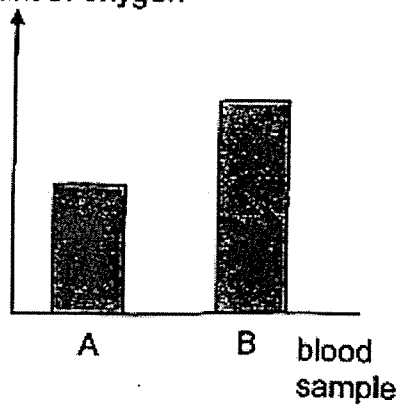

(2) amount of oxygen

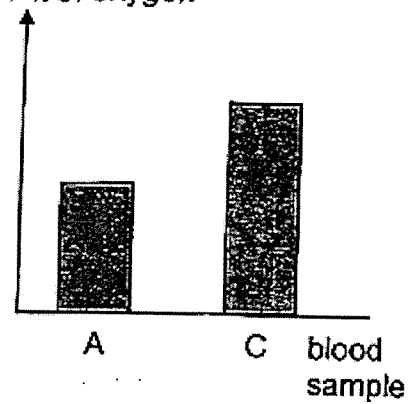

(3) amount of oxygen

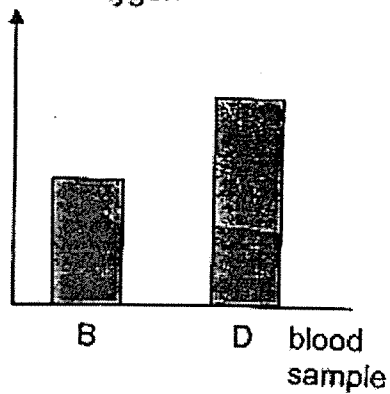

(4) amount of oxygen

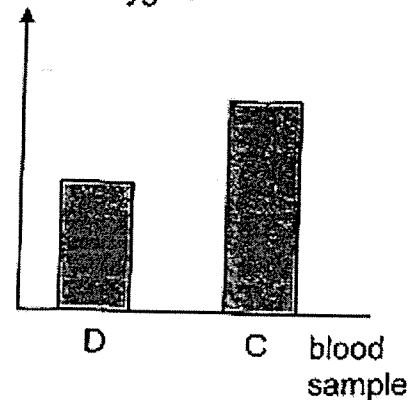

9 Which diagram shows the correct movement of food in a germinating seed?

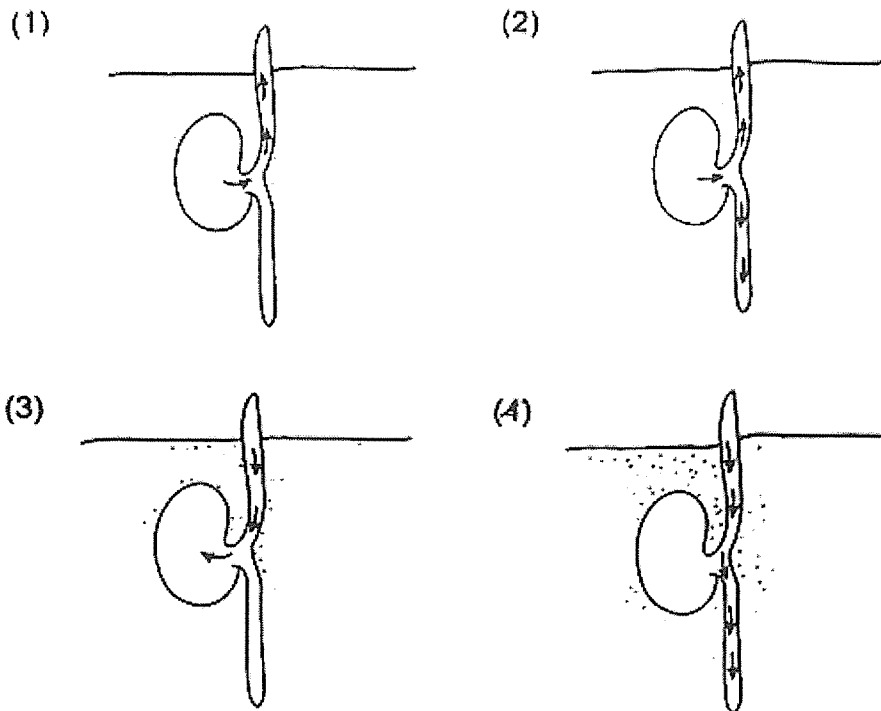

10 The diagram below shows the sexual reproduction parts of a flower and a human.

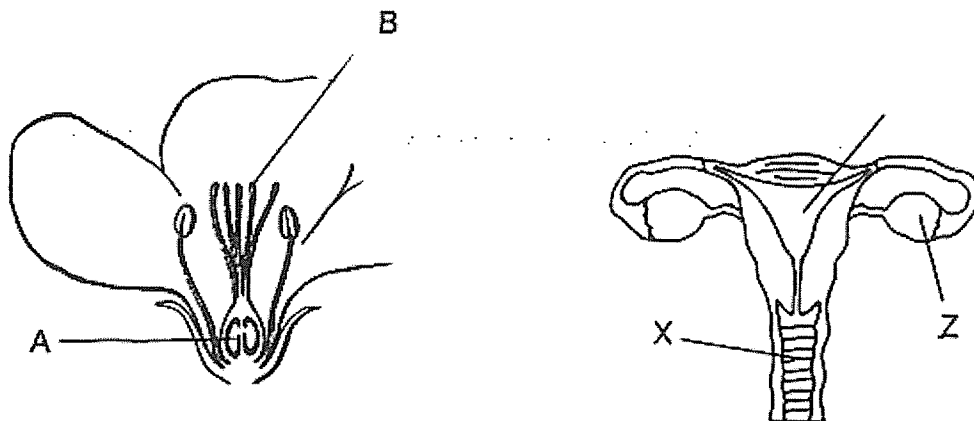

Which of the following correctly shows where the fertilised egg will develop?

- (1) A and X
- (2) A and Y
- (3) B and X
- (4) B and Z

- 11 Taufik set up an experiment to find out whether carbon dioxide is needed for photosynthesis. He used a plant which had leaves with green areas in the middle and white areas round the edges as shown below.

The set-up was placed under the sun.

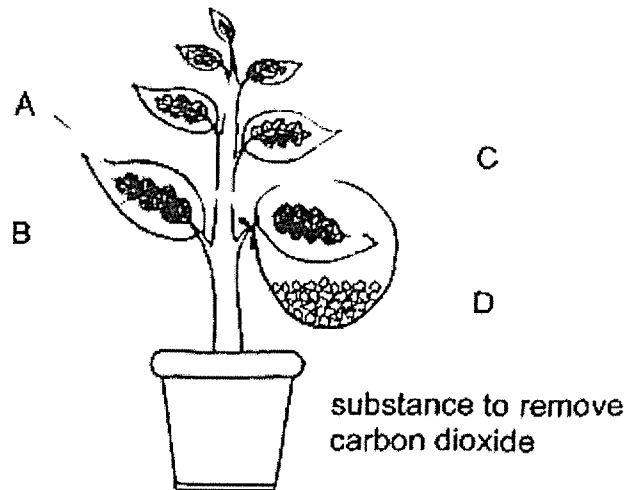

Which of the following areas should Taufik compare to show that carbon dioxide is needed for photosynthesis?

- (1) A and B
- (2) A and C
- (3) B and D
- (4) C and D

12 Study the food web shown below.

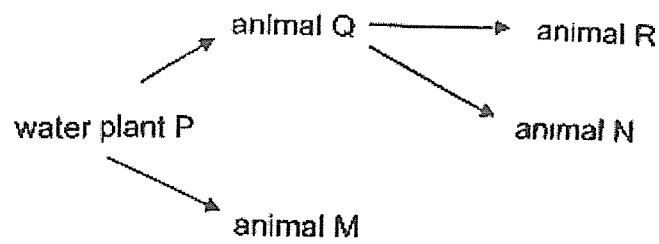

The graph shows the number of animal N over a period of time.

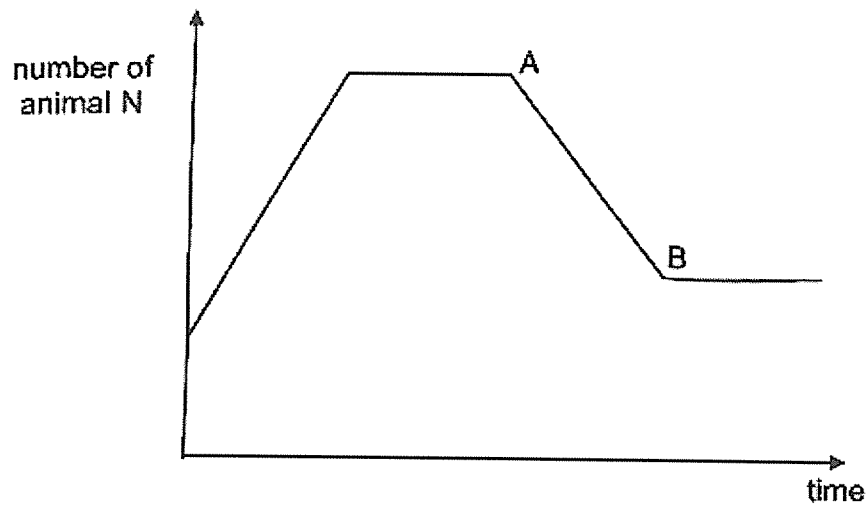

Which of the following explains the change in the number of animal N shown by AB in the graph?

- (1) addition of plant P to the pond
- (2) addition of animal M to the pond
- (3) addition of animal Q to the pond
- (4) removal of animal R from the pond

13 Fruits are formed from the flowers of a plant as shown below.

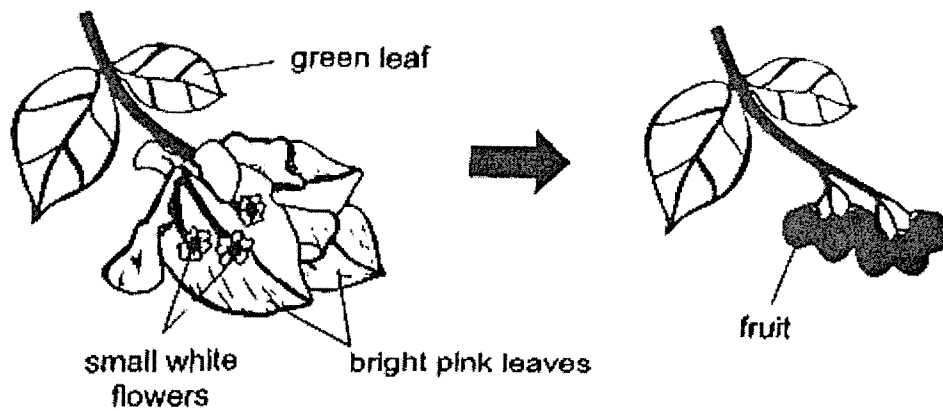

What is the advantage of the plant having bright pink leaves?

- (1) To help in seed dispersal
- (2) To increase the chance of pollination
- (3) To increase the rate of photosynthesis
- (4) To prevent the flowers from being eaten by animals

14 Which of the following is/are result(s) of global warming?

- A more floods
- B more droughts
- C more air pollution
- D more deforestation

- (1) D only
- (2) A and B only
- (3) B and C only
- (4) C and D only

- 15 Weikang placed three solids made of materials X, Y and Z into a tank of water. His observation is shown below.

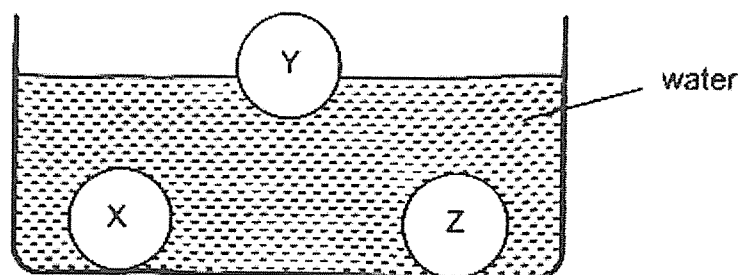

Which of the following statements can be concluded from his observation?

- (1) X and Z are the same material.
 - (2) X and Z are different materials.
 - (3) Y and Z are the same material.
 - (4) Y and Z are different materials.
- 16 A metal container holds 500 cm^3 of water and 200 cm^3 of air as shown below. 100 cm^3 of water was removed from the container through the tap and 50 cm^3 of air was then added using the air pump.

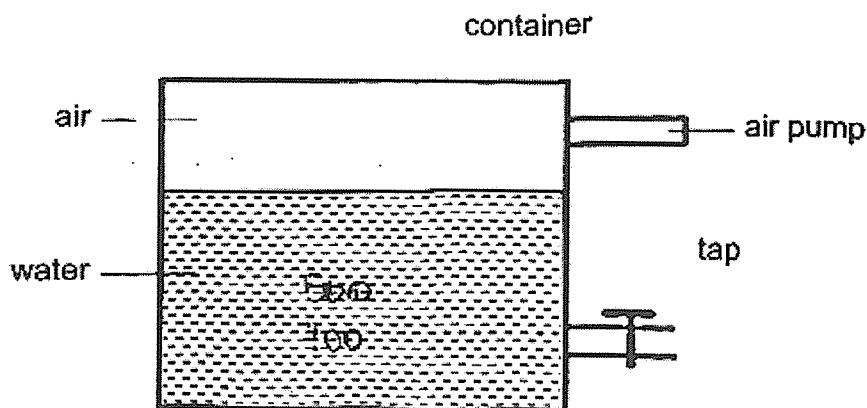

What would be the final volume of the air in the container?

- (1) 250 cm^3
- (2) 300 cm^3
- (3) 350 cm^3
- (4) 650 cm^3

- 17 Jing Rui set up three magnets AB, CD and EF, and an iron bar GH as shown in the diagram below.

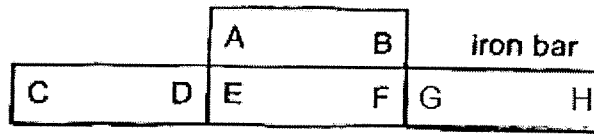

Which of the following arrangements is possible?

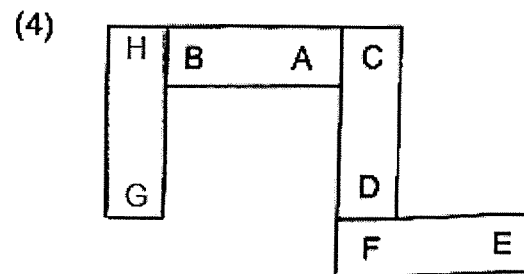
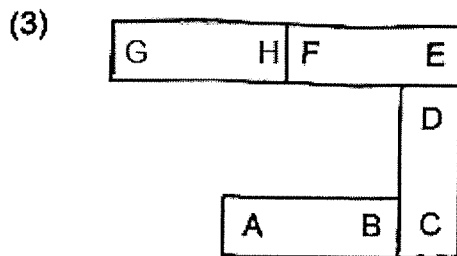
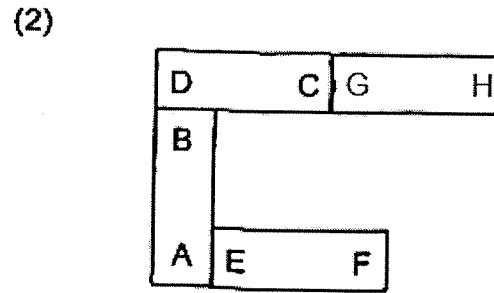
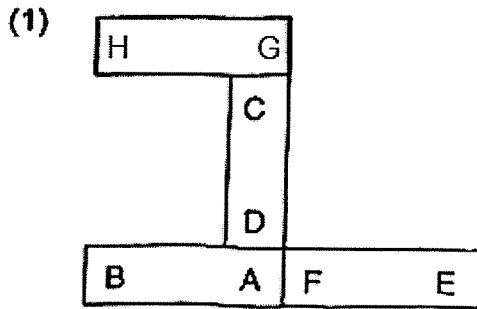

- 18 The set-up below shows light shining on three shapes A, B and C made of cardboard. They are placed at different distances from the torch.

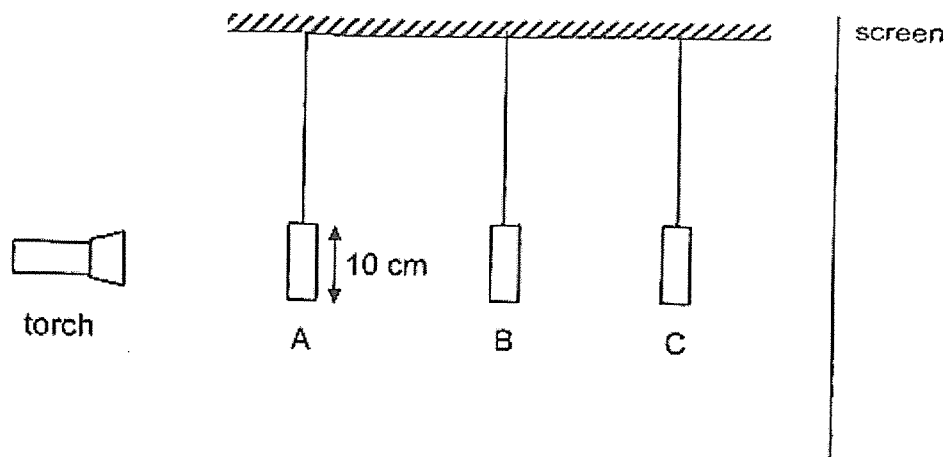

The diagram below shows what was seen on the screen.

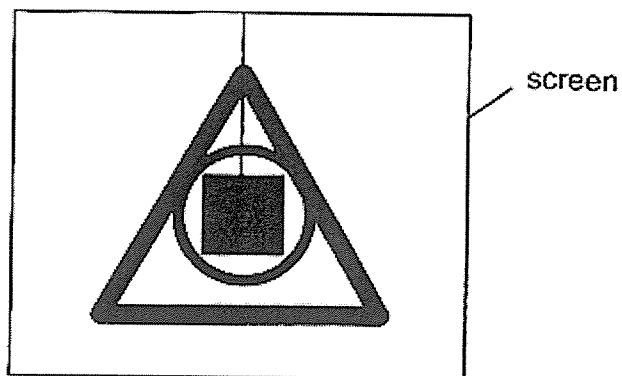

Which of the following represents correctly shapes A, B and C respectively?

	A	B	C
(1)	square	triangle	circle
(2)	square	circle	triangle
(3)	triangle	circle	square
(4)	triangle	square	circle

- 19 Beatrice was holding a metal straw dipped in a glass of iced water. After some time, she felt that the metal straw was cold.

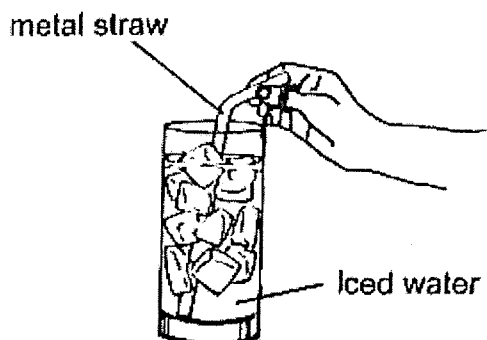

Which one of the following correctly explains why Beatrice felt that the metal straw was cold?

- (1) The metal straw lost heat to the iced water and to her fingers. x
 - (2) The metal straw gained heat from the iced water and from her fingers.
 - (3) The metal straw lost heat to the iced water and gained heat from her fingers.
 - (4) The metal straw gained heat from the iced water and lost heat to her fingers.
- 20 A block of ice was placed in an empty cup and left in the kitchen.

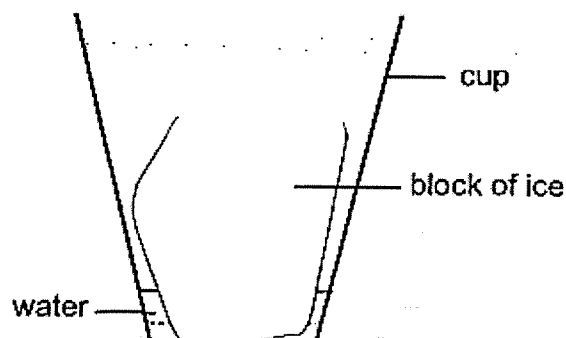

What will happen after some time?

- (1) The temperature of the block of ice increases.
- (2) The temperature of the block of ice decreases.
- (3) The temperature of the water around the block of ice is $0\text{ }^{\circ}\text{C}$.
- (4) The temperature of the water around the block of ice is less than $0\text{ }^{\circ}\text{C}$.

- 21 Samuel filled three identical pots, P, Q and R, with different volumes of hot water at 95 °C.

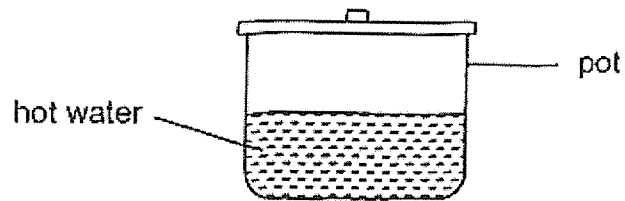

He recorded the time taken for the water in each pot to reach room temperature in the table below.

Pot	Time taken for water to reach room temperature (min)
P	39
Q	22
R	30

Which of the following most likely shows the volume of water (in cm³) in each of the pots?

	P	Q	R
(1)	500	900	700
(2)	500	700	900
(3)	700	900	500
(4)	900	500	700

- 22 Amos conducted an experiment by placing two glass beakers each containing 100 ml of water in the same room. The water in the beakers had different exposed surface areas. He measured the volume of water left in each beaker after some time. Part of his results are shown below.

Beaker	Temperature (°C)	Exposed surface area (cm ²)	Volume of water left (ml)
1	32	A	40
2	32	25	70

Amos repeated the experiment using another two beakers with 100 ml of water. This time, the beakers were kept at different temperatures. Part of his results are shown below.

Beaker	Temperature (°C)	Exposed surface area (cm ²)	Volume of water left (ml)
3	32	25	70
4	T	25	30

What are the possible values of A and T?

	A	T
(1)	10	14
(2)	10	56
(3)	40	14
(4)	40	56

23 The diagram below shows a boy skating from point A to C on the ramp.

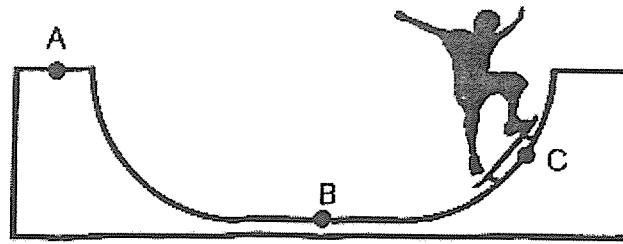

Which of the following correctly shows the amount of gravitational force acting on the boy?

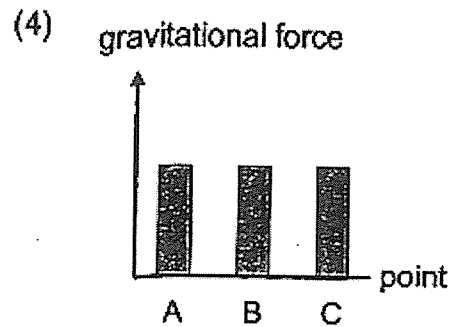
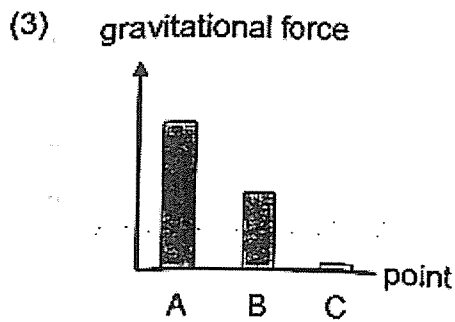
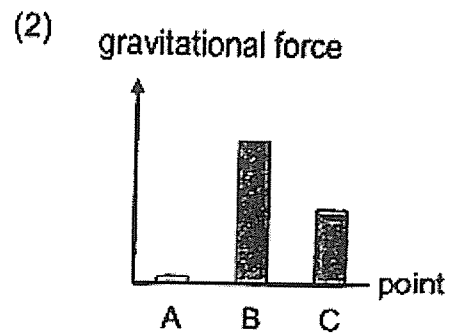
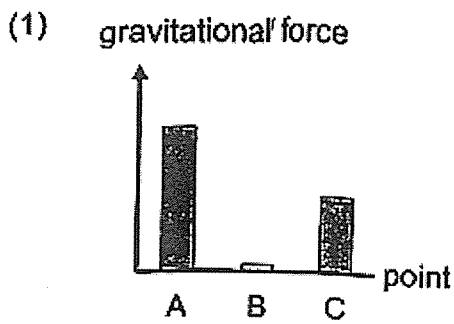

- 24 Aidan conducted an experiment using four springs, W, X, Y and Z. The springs are of the same length when unstretched. He hung a 1 kg load on each of the springs and observed the results below.

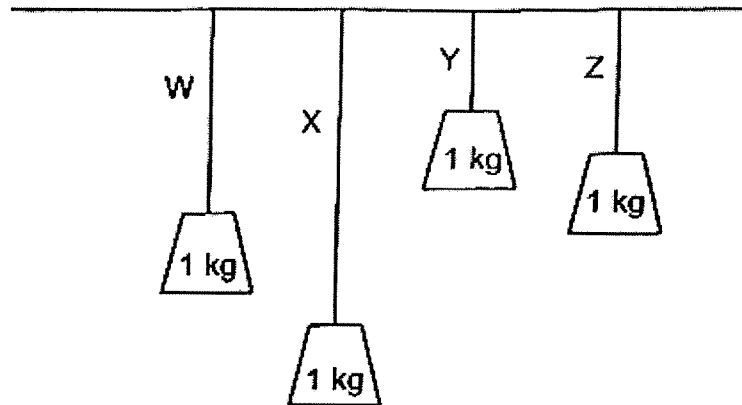

Based on Aidan's results, which of the following is possible when a metal rod is hung equal distance apart from the two springs?

(1)

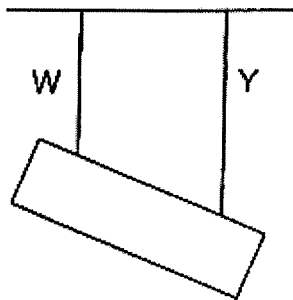

(2)

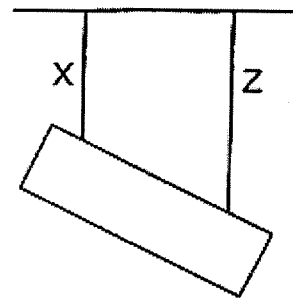

(3)

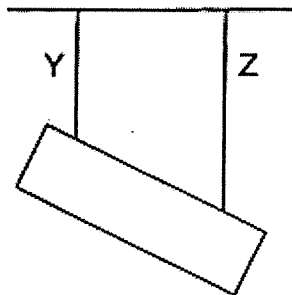

(4)

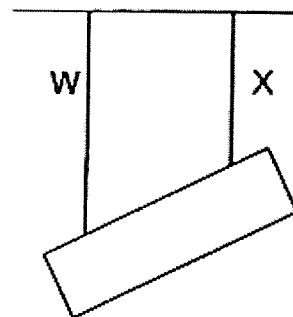

25 Identical batteries and bulbs are used to set up the two circuits.

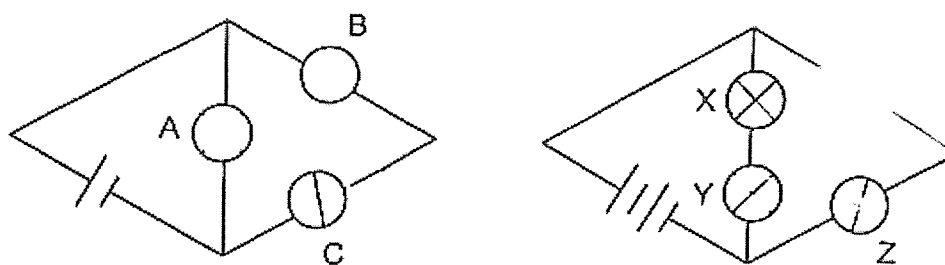

Which of the following is correct about the brightness of the bulbs?

	Dimmest bulb(s)	Brightest bulb(s)
(1)	A	X, Y
(2)	A	Z
(3)	A, B, C	X, Y, Z
(4)	B, C	Z

26 Study the circuit below. The batteries and bulbs are all working properly.

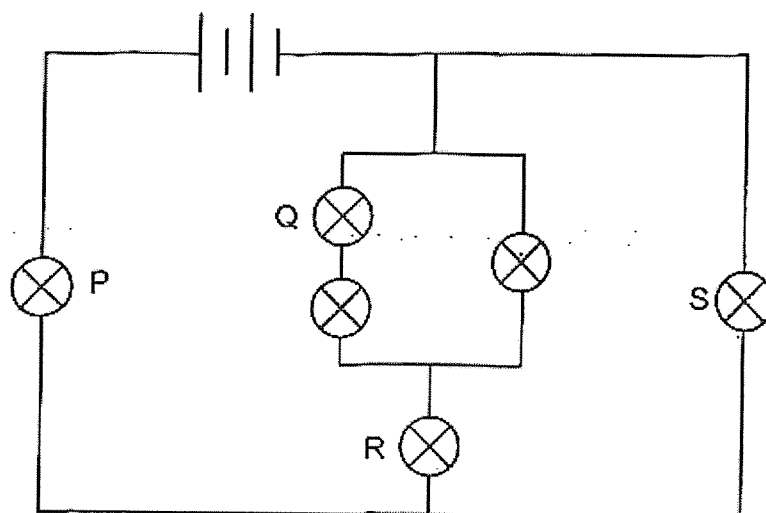

Which one of the following correctly states the number of bulbs that would still be lit when one bulb is blown?

	Bulb that is blown	Number of bulb(s) still lit
(1)	P	5
(2)	Q	2
(3)	R	2
(4)	S	0

- 27 Many countries have solar panels installed on the roof of bus stops. The solar panels help to light up the display board to inform passengers of the arrival time of the buses.

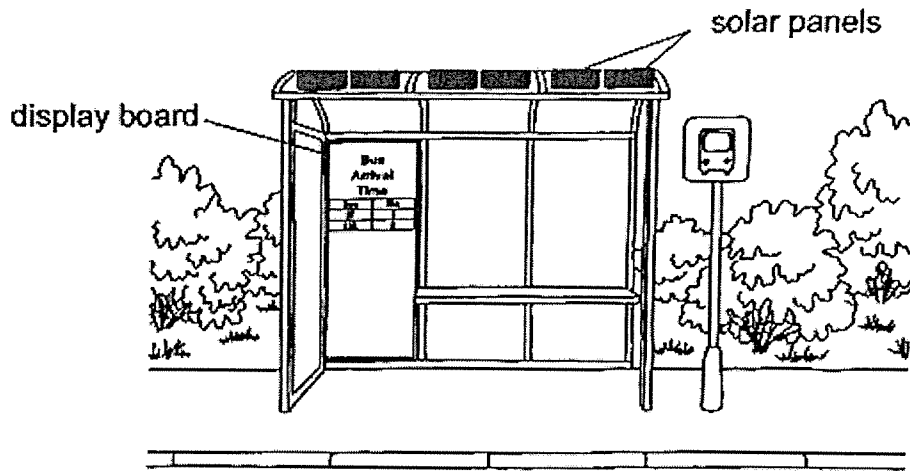

Which of the following shows the energy changes?

- (1) light energy \rightarrow electrical energy \rightarrow light energy
 - (2) light energy \rightarrow potential energy \rightarrow kinetic energy
 - (3) heat energy \rightarrow electrical energy \rightarrow kinetic energy
 - (4) kinetic energy \rightarrow potential energy \rightarrow light energy
- 28 A beanbag was tossed into the air and moved from A to B as shown in Figure 1. It then dropped from B to A as shown in Figure 2.

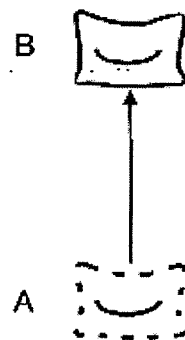

Figure 1

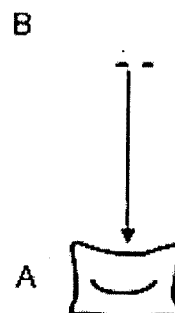

Figure 2

Which one of the following is correct?

	Potential energy of the beanbag from A to B	Kinetic energy of the beanbag from B to A
(1)	increases	decreases
(2)	increases	increases
(3)	decreases	decreases
(4)	decreases	increases

End of Section A

Index No.

--	--	--	--	--

--

PEI CHUN PUBLIC SCHOOL

PRIMARY 6

PRELIMINARY EXAMINATION 2023

SCIENCE

(BOOKLET B)

Total Time for Booklets A and B: 1 h 45 min

Name: _____ ()

Class: Primary 6 / () _____

Date: 22 August 2023

Science Teacher: _____

SECTION A	56
SECTION B	44
TOTAL	100

Parent's Signature: _____

INSTRUCTIONS TO CANDIDATES

1. Do not turn over this page until you are told to do so.
 2. Follow all instructions carefully.
 3. Answer all questions.
 4. Write your answers in this booklet.
-

Section B (44 marks)

For questions 29 to 40, write your answers in the spaces provided.

29 The diagram below shows a single-celled organism.

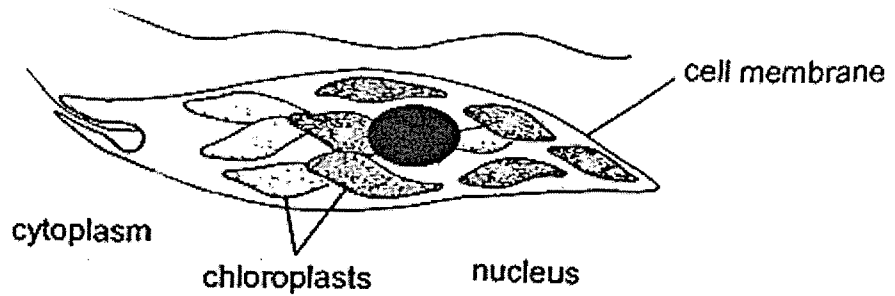

The organism can be classified as an animal or a plant by different scientists.

- (a) Based on the diagram, give a reason why some scientists classify it as a plant cell. [1]

- (b) Based on the diagram, give a reason why some scientists classify it as an animal cell. [1]

30 The diagram below shows a human body system.

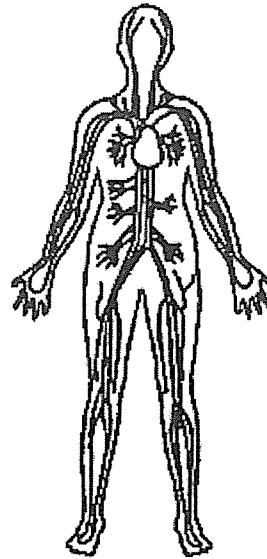

(a) Name three parts in the human system shown above. [1]

(b) Describe how the digestive system works together with the circulatory system to transport food around our body. [2]

31 The diagram shows how a fruit is formed from a flower of plant P.

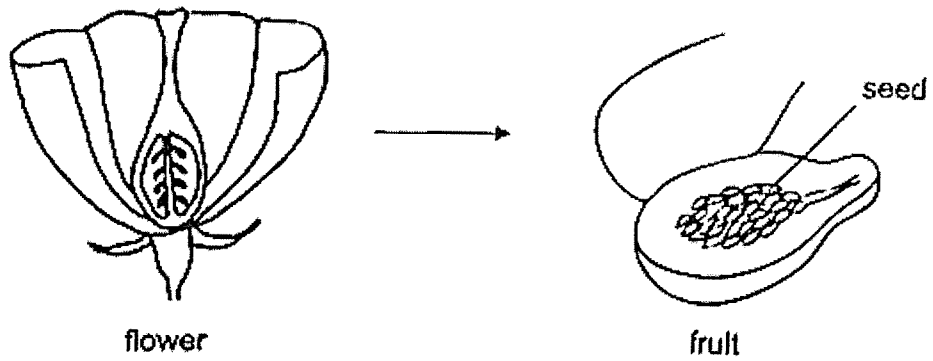

(a) State the part of the flower that the seed developed from. [1]

(b) The fruits of plant P are juicy and contain many small and hard seeds. Describe how these characteristics help in the dispersal of the seeds of plant P over a wide area. [2]

(c) State one advantage of this method of dispersing seeds for plant P. Explain your answer. [1]

32 The animal waste from a farm flows into a nearby river.

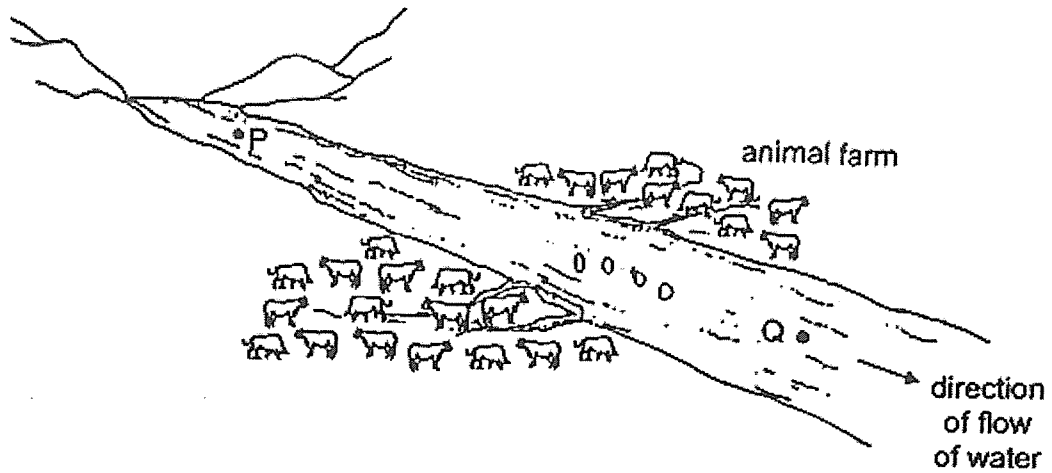

- (a) A scientist collected the same amount of water from points P and Q of the river. He measured the amount of nutrients and oxygen in the water.

His results are shown below.

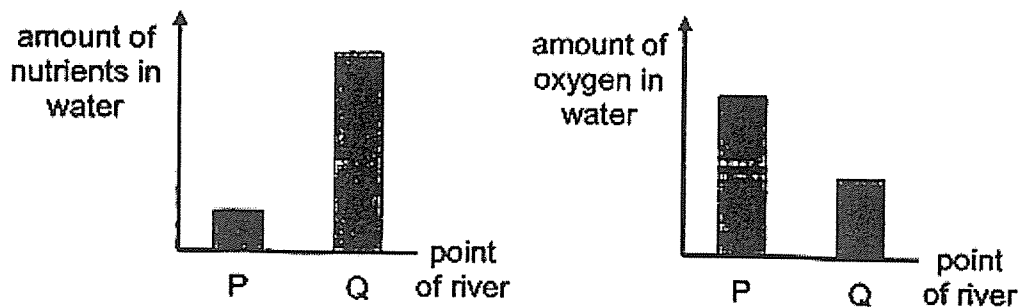

Explain why the water at point Q had less oxygen.

[2]

- (b) The animals feed on the grass growing near the river. As a result, more soil was washed into the river by the rain.

Explain how the removal of the grass caused more soil to be washed into the river.

[1]

SCORE	
-------	--

- 33 Alice wanted to find out if plant X carries out photosynthesis faster under red light or blue light. She conducted an experiment in a dark room as shown below.

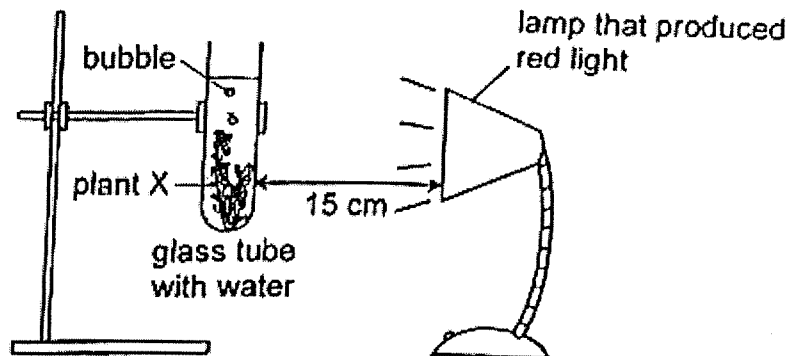

She switched on the lamp that produced red light and counted the number of bubbles produced by plant X in one minute. She repeated her experiment with a lamp that produced blue light. The coloured lights were of the same brightness.

- (a) (i) Name the gas in the bubble produced by plant X. [1]

- (ii) State a hypothesis on how red and blue light affects the number of bubbles produced by plant X. [1]

SCORE	
-------	--

- (b) Alice conducted another experiment in a dark room as shown below, using the same amount of plant X in identical glass tubes. She added a few drops of liquid Y to the water in each tube.

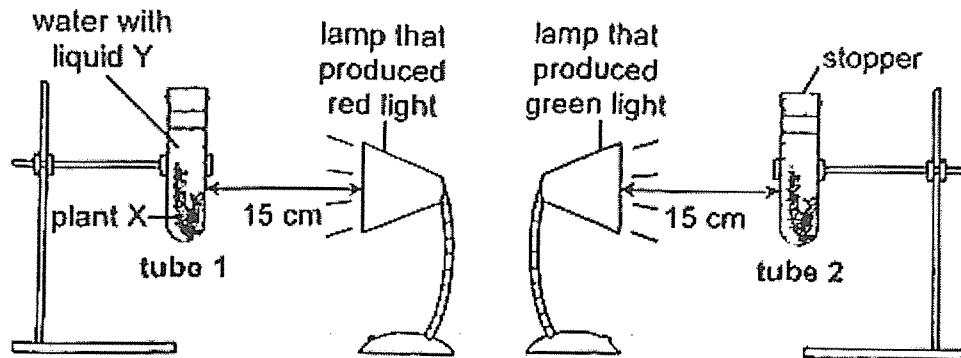

Liquid Y changes colour as shown below.

Amount of carbon dioxide in water	less than normal	normal	higher than normal
Colour of water with liquid Y	purple	orange	yellow

- (i) At the start of the experiment, the water with liquid Y in each tube was orange. She read that plant X carries out photosynthesis under red light but does not carry out photosynthesis under green light.

What would be the colour of liquid Y in each tube after five hours?
Circle the correct answer for each tube.

[1]

tube 1 (red light): *purple* / *orange* / *yellow*

tube 2 (green light): *purple* / *orange* / *yellow*

- (ii) Explain your answer for tube 2 in (b)(i).

[1]

SCORE	
-------	--

34 Bird M lives in groups on rocky cliffs.

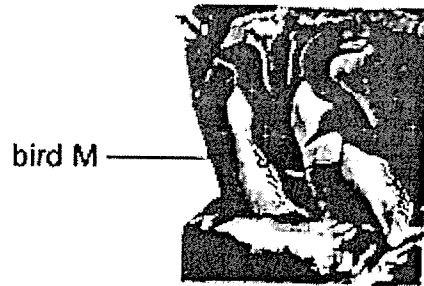

- (a) The adult male bird M points its head vertically and makes loud croaking noises when a female adult bird M is nearby. Suggest how this behaviour benefits the male bird. [1]

- (b) The adult bird M does not build a nest. It lays its egg on the narrow cliff ledge as shown in diagram 1. Diagram 2 shows the egg of bird M.

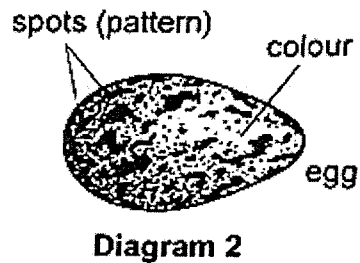
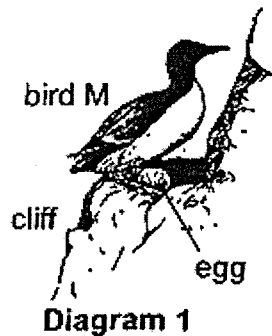

- (i) The egg of bird M is pointed at one end. When pushed, it does not roll off in a straight path like a round egg. It rolls around in a circle as shown below.

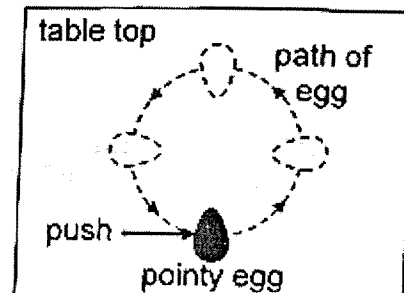
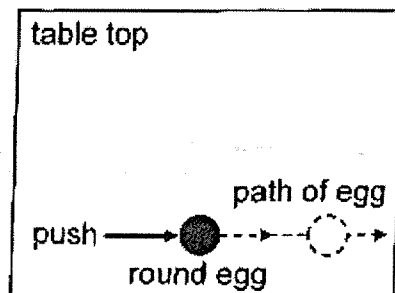

Based on the information given, explain how the shape of the egg helps bird M to survive. [2]

- (ii) An adult bird M lays only one egg each year and many adults lay their eggs close to one another in the same month of the year.

Each egg of bird M has a different colour and pattern from all the other eggs. Give a reason why this is an advantage to the adult bird M. [1]

- (c) Bird M hunts for food in the sea. As it dives into the water, it folds its wings close to its body as shown below.

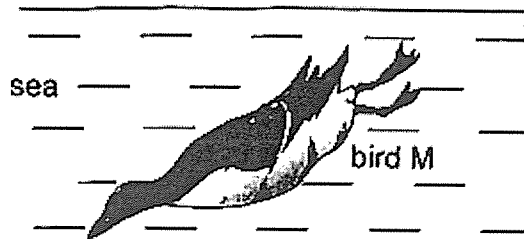

Explain how this action allows the bird to move quickly in the water. [1]

SCORE	
-------	--

35 Mdm Phua filled a jug with some liquid X.

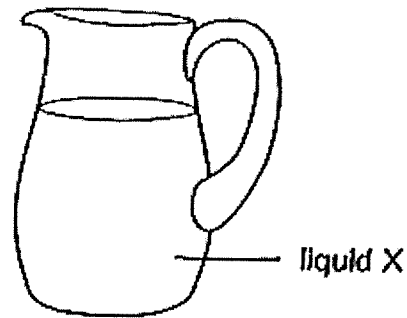

(a) Describe what she could do to find the mass of liquid X inside the jug if she had the following things only:

- beaker
- measuring cylinder
- electronic balance

She need not use all of the above things.

[2]

(b) Mdm Phua poured liquid X into a glass shown below.

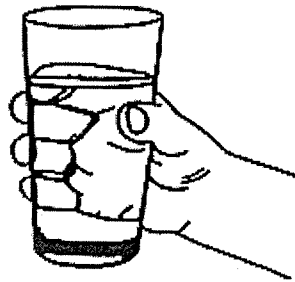

State a property of liquid X that allowed it to flow into the glass easily. [1]

SCORE	
-------	--

- 36 Daisy set up an experiment in a dark room. She wanted to investigate the amount of light that can pass through materials P, Q and R using the set-up shown below.

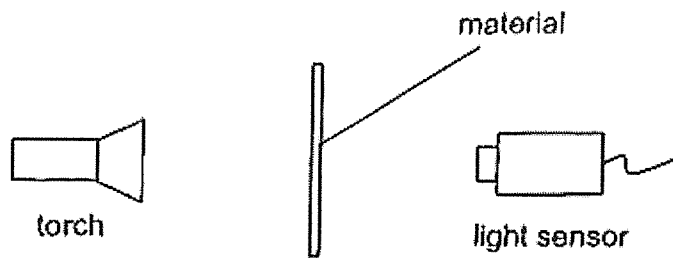

The graph shows her results.

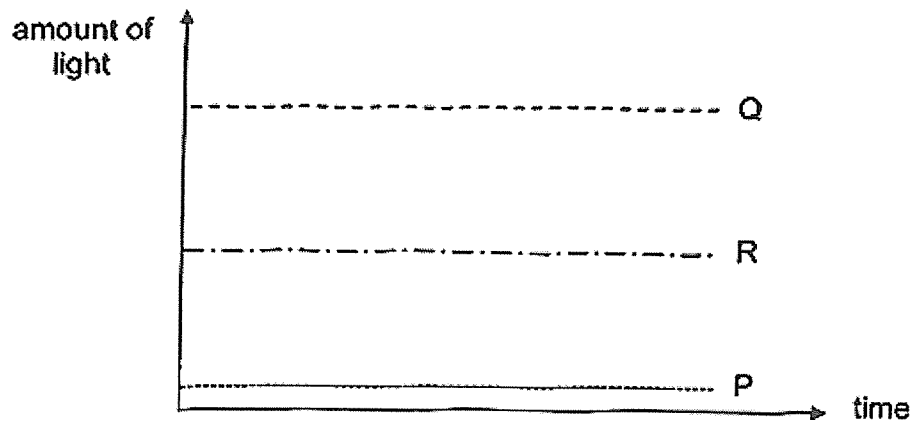

- (a) State two variables of the materials that were fixed so that the experiment was a fair test. [2]

- (b) Daisy used a dark room to conduct the experiment. Give a reason how using the dark room helps to make the experiment a fair test. [1]

- (c) Based on Daisy's experiment, which material, P, Q or R, is most suitable for making part X of the goggles? Give a reason for your answer. [1]

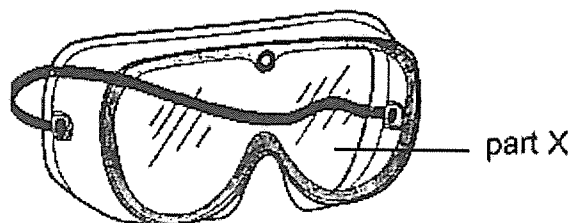

SCORE	
-------	--

37 (a) State what is temperature.

[1]

(b) Ahmad placed a thick piece of glass on a heater as shown.

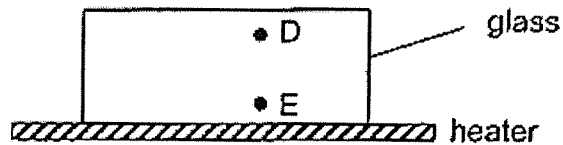

The graph below shows the temperature of the glass at different distances from the heater after five minutes.

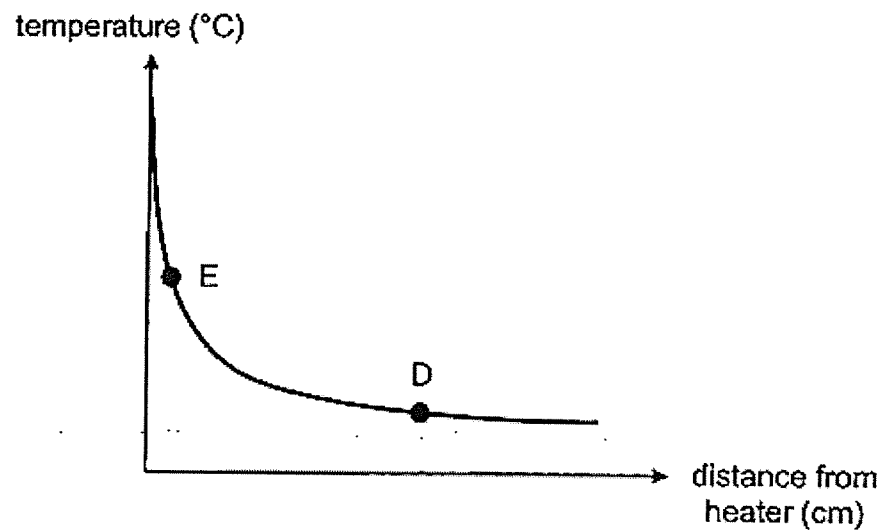

Explain why the temperatures at D and E are different.

[1]

- (c) Ahmad used a glass container with thick walls to contain hot food. When he placed the container in the freezer, cracks appeared on the container as shown.

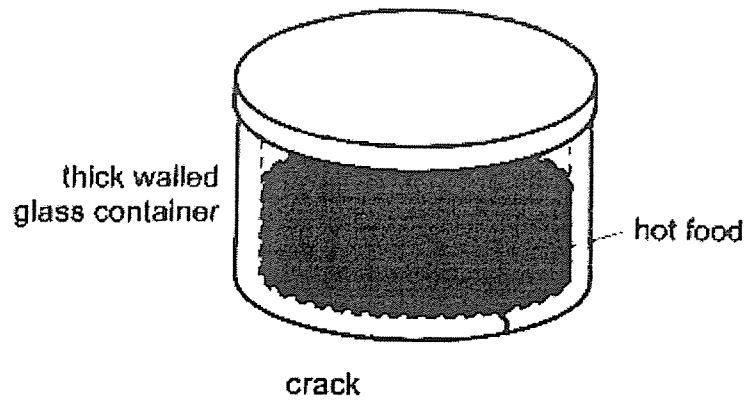

Explain how the change in temperature caused the container to crack. [2]

- 38 Gregory performed an experiment on two different types of springs, A and B, of the same length using the set-up shown in Diagram 1.

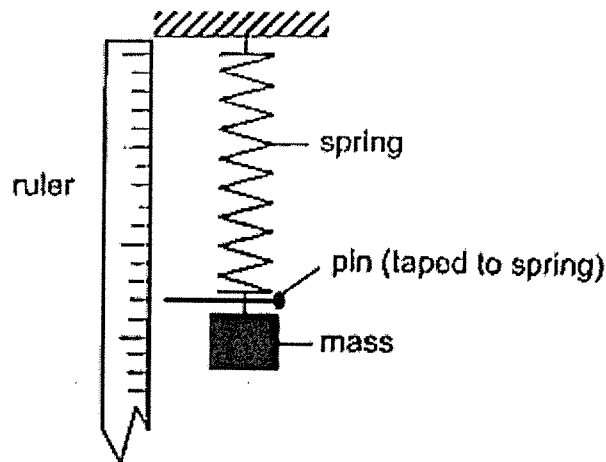

Diagram 1

He measured the extension of the spring after adding a mass. His results are shown in Table 1 below.

Mass hung on spring (g)	Spring A extension (cm)	Spring B extension (cm)
50	4.0	0.9
100	8.1	2.0
150	11.9	2.9
200	16.1	4.1

Table 1

- (a) Based on the results of his experiment, state the relationship between the mass hung on spring and extension of spring A. [1]

- (b) Explain the purpose of the pin in the set-up. [1]

- (c) Gregory carried out the following experiment. He placed spring A over a wooden rod and pressed it down by 2 cm. When he let go of spring A, the spring jumped up to a height of 10 cm.

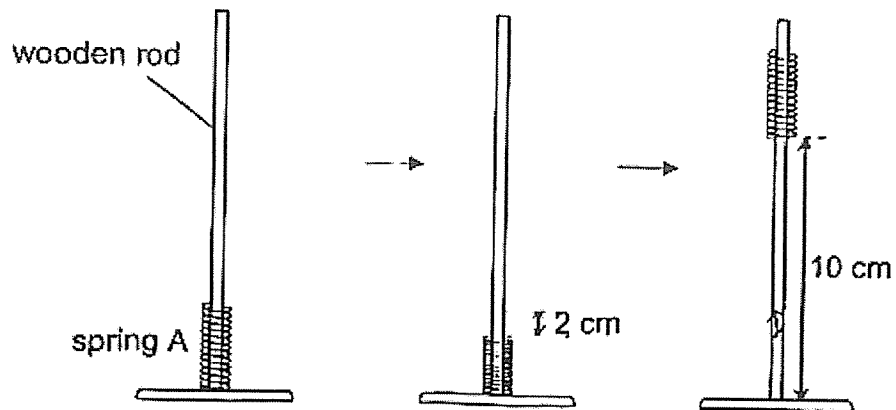

He repeated the experiment with spring B, pressing it down by 2 cm.

When he let go of spring B, would the height reached by spring B be *less than*, *equal to* or *more than* 10 cm?

Based on the results in Table 1, explain your answer using the energy change that took place. [2]

SCORE	
-------	--

39 Fook Ming constructed a circuit as shown in Diagram 1.

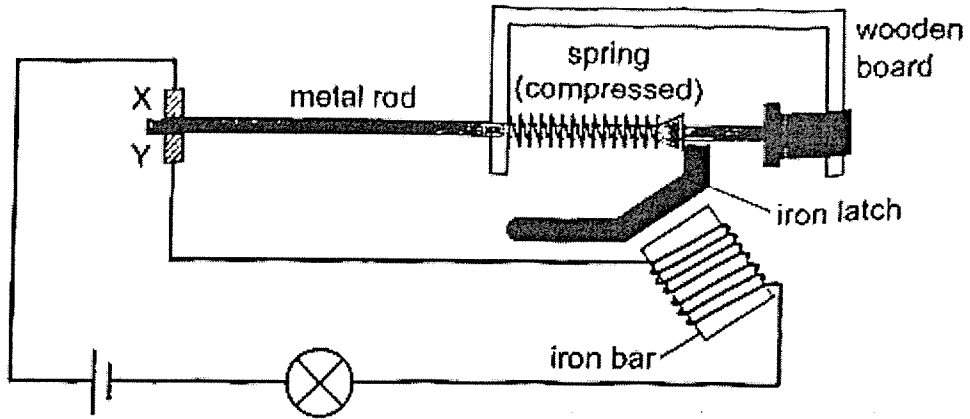

Diagram 1

This circuit prevents the bulb from fusing when the amount of electric current becomes too high. When Fook Ming added 3 more batteries, one end of the iron latch moves down as shown in Diagram 2. The metal rod moves to the right, away from parts X and Y, and the bulb is turned off.

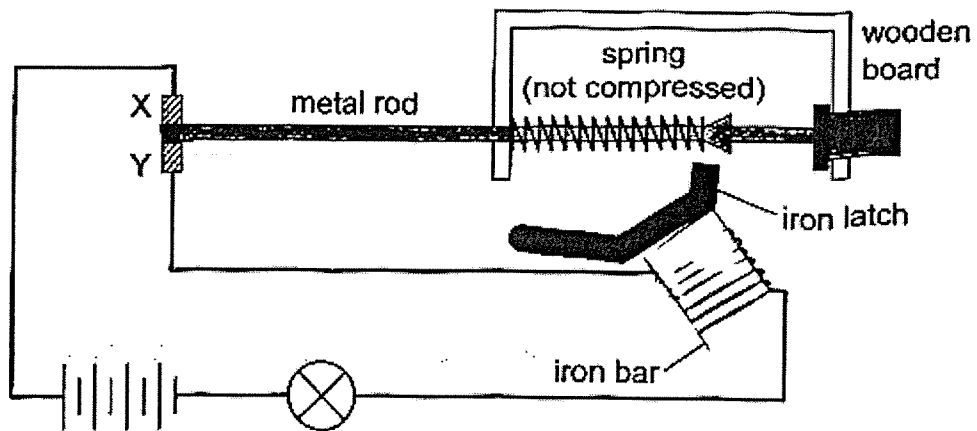

Diagram 2

- (a) Parts X and Y are made of the same material.
State a property of this material that allows the circuit to work. [1]

- (b) Explain how the bulb is turned off when Fook Ming added 3 more batteries. [2]

SCORE	
-------	--

(c) Fook Ming wants the bulb to be turned off with fewer batteries added.

Suggest a change that he can make to the circuit. Explain your answer. [2]

SCORE	
-------	--

40 Dan parked his car and left the air-conditioner switched on.

inside of car: 17 °C

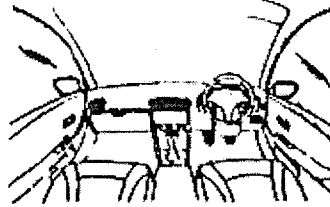

outside of car: 35 °C

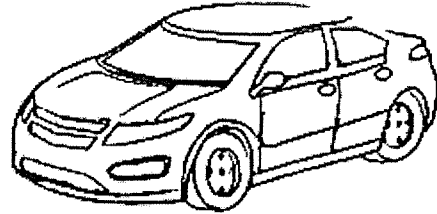

- (a) Dan observed that the windows became fogged after some time. Explain how the windows became fogged. [2]

- (b) Dan used his finger to write his name on the fogged window.

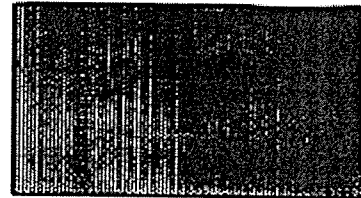
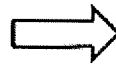
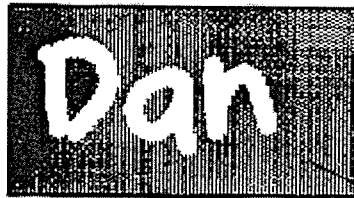

water droplets

The word Dan wrote disappeared after a while.
Explain why the word disappeared.

[1]

End of Section B

SCORE	
-------	--

SCHOOL : PEI CHUN PRIMARY SCHOOL
LEVEL : PRIMARY 6
SUBJECT : SCIENCE
TERM : 2023 PRELIM

SECTION A

Q 1	Q2	Q3	Q4	Q5	Q6	Q7	Q8	Q9	Q10
3	3	1	4	1	3	3	3	2	2
Q 11	Q12	Q13	Q14	Q15	Q16	Q17	Q18	Q19	Q20
3	2	2	2	4	2	2	3	3	3
Q 21	Q22	Q23	Q24	Q25	Q26	Q27	Q28		
4	4	4	3	4	3	1	2		

Name: _____ ()

Class: P6 / ()

PEI CHUN PUBLIC SCHOOL
PRELIMINARY EXAMINATION – 2023

No.	Acceptable Answers
29 a)	<p><i>Concept: Comparison between animal and plant cell</i></p> <p>The organism <u>has chloroplasts</u> and only plant cells have chloroplasts.</p>
29 b)	<p><i>Concept: Comparison between animal and plant cell</i></p> <p>The organism <u>does not have a cell wall</u> and animals cell do not have cell wall</p>
30 a)	<p><i>Concept: Parts of the circulatory system</i></p> <p>Blood, blood vessels and heart.</p>
30 b)	<p><i>Concept: Different body systems work together to carry out life processes</i> <i>You need to describe how digested food enters the blood (digestive system) and how the digested food is transported to the rest of the body (circulatory system).</i></p> <p><u>Food enters the body through the mouth and is broken down into simpler substances in the mouth, stomach and small intestine. The digested food is absorbed into the blood in the small intestine. The heart pumps the blood to transport the digested food to the rest of the body.</u></p>
31 a)	<p><i>Concept: After fertilisation, the ovules in the ovary start developing into seeds. The ovary enlarges and becomes a fruit.</i></p> <p>ovule / ovules</p>
31 b)	<p><i>Concept: Animals help plants in dispersing their seeds.</i> <i>To help disperse the seeds over a wide area, the animals need to move about and away from the parent plant before they disperse the seeds.</i></p> <p><u>The animals eat the juicy fruits with the small seeds. As they move about, they pass out the undigested seeds in their droppings.</u></p>
31 c)	<p><i>Concept: Advantage of seed dispersal by animals</i></p> <ol style="list-style-type: none"> 1. The <u>droppings</u> of the animals <u>provide nutrients</u> for the young plants. 2. The <u>seeds are dispersed far away from the parent plant</u> to prevent overcrowding and competition for sunlight, water and minerals between the parent plant and the young plants.
32 a)	<p><i>Concept: Water pollution (Negative impact of man's activities)</i></p> <ol style="list-style-type: none"> 1. The <u>animal waste washed into the river was broken down / decomposed by bacteria in the water</u> into simpler substances (nutrients). The <u>number of bacteria in the water increased</u> and the <u>bacteria took in more oxygen</u> from the water.

	<p>2. The <u>number of floating water plants</u> increased as there was more nutrients in the water. The floating plants <u>blocked sunlight from reaching the plants growing at the bottom of the river</u> (submerged plants). The <u>plants at the bottom of the river could not carry out photosynthesis and produce oxygen.</u></p>
32 b)	<p><i>Concept: Overgrazing can lead to soil erosion</i></p> <p>When the grass was removed, there were <u>no roots to hold the soil together</u> and <u>no leaves to break the impact of the rain on the soil.</u> Thus, more soil was washed into the river by the rain.</p>
33 a)	<p><i>Concept: During photosynthesis, plants produce oxygen.</i></p> <p>oxygen</p>
33 aii)	<p><i>Process skills – Writing a hypothesis</i> <i>A hypothesis is a prediction of the outcome of the experiment.</i> <i>Refer to the aim of the experiment. The rate of photosynthesis is measured by counting the number of bubbles produced by the plant.</i></p> <p>Plant X produces more bubbles under red light. OR Plant X produces more bubbles under blue light.</p>
33 bi)	<p><i>Concept: During photosynthesis, plants take in carbon dioxide.</i></p> <p>set-up 1 (red light): purple (<i>The plant took in carbon dioxide for photosynthesis.</i>) set-up 2 (green light): yellow</p>
33 bii)	<p><i>Concept: Plants are living things. They take in oxygen to break down the food they make to give them energy. Carbon dioxide is produced during this process.</i></p> <p><u>Plant Z would produce carbon dioxide.</u> The amount of carbon dioxide in the water would increase, turning liquid Y yellow.</p>
34 a)	<p><i>Concept: Animals have adaptations to help them find and attract a mate in order to reproduce, such as body coverings, behaviour and lighting up.</i></p> <p>The male bird M can <u>attract the female bird M to mate with it.</u></p>
34 bi)	<p><i>Concept: Adaptations help living things to cope with physical factors</i></p> <p>The eggs of bird M <u>will not roll off the cliff easily and be destroyed.</u> Thus, <u>more of their eggs can hatch</u> into young.</p>
34 bii)	<p><i>Concept: Adaptations help living things to escape predators</i></p> <p>It allows the <u>parent birds</u> to be able to <u>identify their egg.</u></p>
34 c)	<p><i>Concept: Adaptations help living things to move swiftly in water</i></p> <p>The action helps in <u>reducing water resistance.</u></p>

35 a)	<p><i>Concept: Using apparatus to obtain accurate measurement</i> <i>Step 1: Measure container with X using balance</i> <i>Step 2: Measure container without X and subtract</i></p> <p>First, she should measure the mass of jug with liquid X with the electronic balance. Next, she should pour out all the liquid X in the jug into the beaker and measure the mass of the empty jug with the electronic balance. To find the mass of liquid X, she will have to subtract the mass of the empty jug from the mass of the jug with liquid X.</p>
35 b)	<p><i>Concept: Property of liquid</i></p> <p>Liquid X <u>has no definite</u> shape. Thus, it can take the shape of its container / the glass.</p>
36 a)	<p><i>Concept: Process skills – Conducting a fair test</i> <i>You have to state a variable of the materials.</i></p> <p>1. thickness of material 2. size of material</p>
36 b)	<p><i>Concept: Process skills - Conducting a fair test</i></p> <p>To ensure that the torch is the <u>only light source</u> in the experiment.</p>
36 c)	<p><i>Concept: Different materials allow different amount of light to pass through them</i></p> <p><u>Material Q</u>. Q allowed the <u>most</u> amount of light to pass through it.</p>
37 a)	<p><i>Concept: Definition of temperature (Note: temperature ≠ heat)</i></p> <p>Temperature is the <u>measure of degree of hotness</u> of an object.</p>
37 b)	<p><i>Concept: Matter gains / loses heat</i></p> <p>As E was nearer to the heater, E gained heat faster / gained more heat from the heater than D. (Glass is a poor conductor of heat. It would take a much longer time for heat to be conducted from the heater to D. Thus, there was a significant temperature difference between D and E.)</p>
37 c)	<p><i>Concept: Matter loses heat and contracts.</i></p> <p>As the <u>outer wall of the glass container was nearer to the cold air in the freezer</u>, it <u>lost heat faster to the cold air in the freezer</u> and <u>contracted more than the inner wall</u>. There was <u>uneven contraction</u> and the <u>container cracked</u>. OR As the <u>outer wall</u> was exposed to the cold air in the freezer, it <u>lost heat to the cold air and contracted</u>. The <u>inner wall</u> is in contact with the hot food, so it <u>gained heat from the hot food and expanded</u>. Thus, the container cracked.</p>
38 a)	<p><i>Process skills - Interpreting data from graph/tables, identifying relationship between variables</i></p> <p>As the mass hung on spring A increases, the extension of the spring increases.</p>

38 b)	<p><i>Process skill: Improving the accuracy of results by using the right instrument</i></p> <p>To obtain a (more) accurate reading of the length of the spring</p>
38 c)	<p><i>Concept: A compressed spring has elastic potential energy</i> <i>You have to refer to the data in Table 1 to compare the two springs.</i></p> <p><i>Released: Elastic potential energy in compressed spring → Kinetic energy in moving spring</i> <i>Moving up: Kinetic energy in moving spring → Gravitational potential energy of spring</i></p> <p><i>Observation: The toy will reach a height that is <u>more than 10 cm</u>.</i></p> <p><i>Explanation:</i> <u>Spring B is a stiffer spring / compresses less easily than spring A.</u> When compressed by 2 cm, <u>spring B has more (elastic) potential energy than spring A.</u> When spring B was released, its <u>(elastic) potential energy was converted to kinetic energy.</u> Spring B was able to <u>jump higher</u> as it had more kinetic energy to be <u>converted to (gravitational) potential energy.</u></p>
39 a)	<p><i>Concept: Electrical conductors allow electric current to flow through easily, e.g. metal.</i></p> <p>conductor of electricity</p>
39 b)	<p><i>Concept: Changing the number of number of batteries affects the strength of the electromagnet</i></p> <p><u>The iron bar is an electromagnet.</u> When more batteries are added, <u>the attraction from the magnetised iron bar is strong enough to attract the iron latch.</u> <u>The spring returns to its original length, pushing the metal rod outwards.</u> The metal rod is <u>no longer in contact with X and Y and circuit is open.</u></p>
39 c)	<p><i>Concept: Changing the number of coils affects the strength of the electromagnet</i></p> <p><i>Suggestion: Add more coils / turns of wire around the iron bar.</i></p> <p><i>Explanation: The iron bar will become a stronger electromagnet / attract the iron latch with a <u>greater force.</u></i></p>
40 a)	<p><i>Concept: Condensation is a change in state of water from a gas to a liquid due to heat loss.</i></p> <p><u>Warm water vapour in the air outside the car</u> came into contact with the <u>cooler outer glass window, lost heat and condensed</u> into tiny water droplets.</p>
40 b)	<p><i>Concept: Evaporation is a change in state of water from a liquid to a gas due to heat gain.</i></p> <p><u>More water droplets were formed</u> on the area where Dan wrote the word.</p>

