

METHODIST GIRLS' SCHOOL

Founded in 1887



PRELIMINARY EXAMINATION 2023 PRIMARY 6 SCIENCE

BOOKLET A

Total Time for Booklets A and B: 1 hour 45 minutes

INSTRUCTIONS TO CANDIDATES

Do not turn over this page until you are told to do so.

Follow all instructions carefully.

Answer all questions.

Shade your answers in the Optical Answer Sheet (OAS) provided.

Name: _____ ()

Class: Primary 6. _____

Date: 23 August 2023

This booklet consists of 20 printed pages including this page.

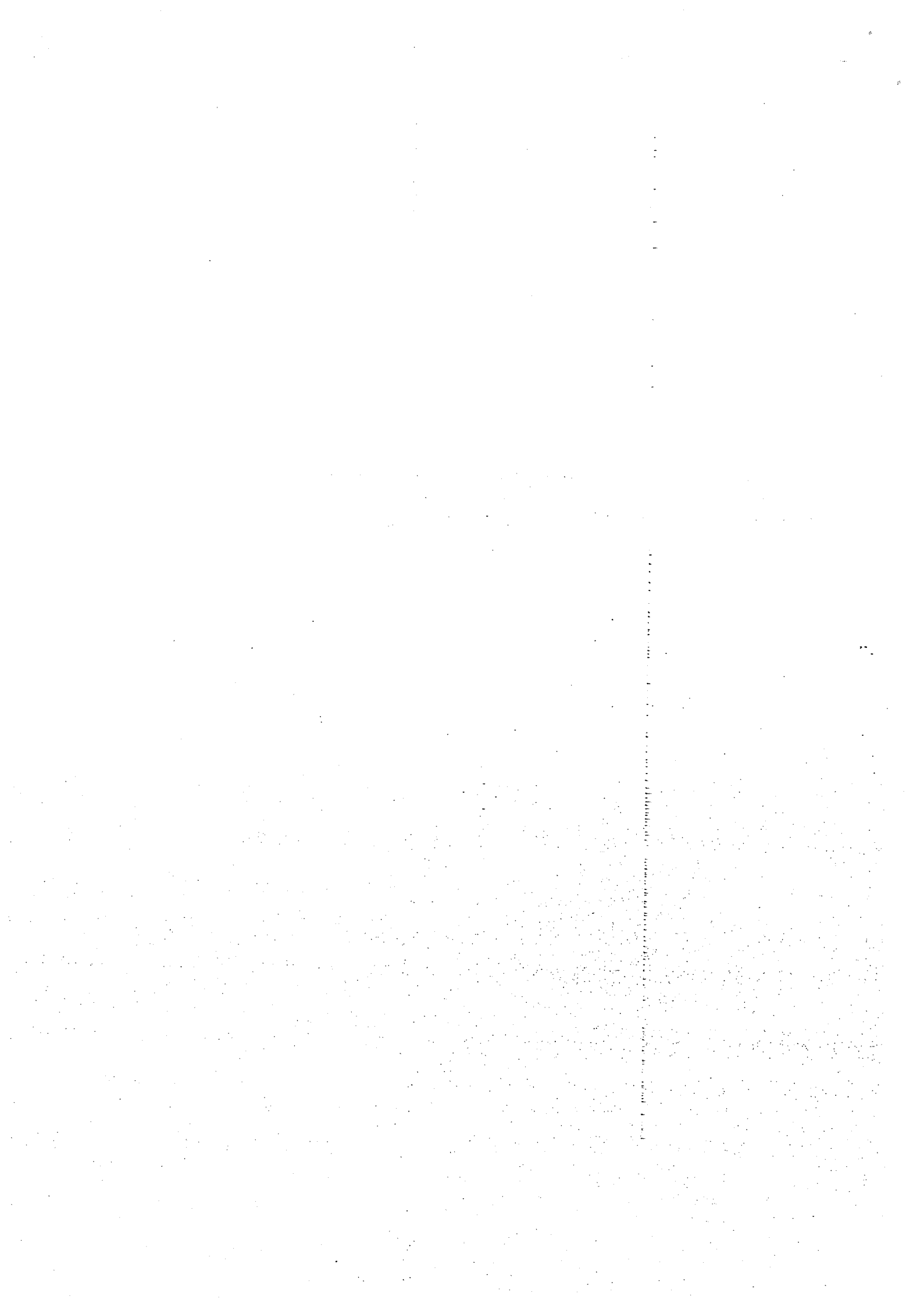

For each question from 1 to 28, four options are given. One of them is the correct answer. Make your choice (1, 2, 3 or 4). Shade the correct oval on the Optical Answer Sheet (OAS).

[56 marks]

- 1 Lisa observed a group of living things under a microscope over four days.

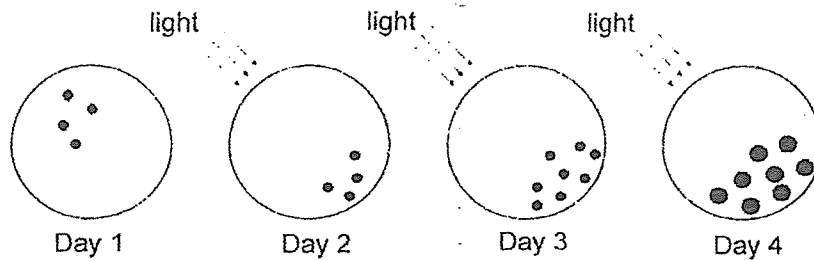

She then made the following statements about her observations of the group of living things.

- A: They can die.
- B: They can grow.
- C: They can reproduce.
- D: They can respond to changes.

Which statement(s) is/are correct?

- (1) A and D only
 - (2) B and C only
 - (3) B, C and D only
 - (4) A, B, C and D
- 2 Zebras are well adapted to live on grasslands.

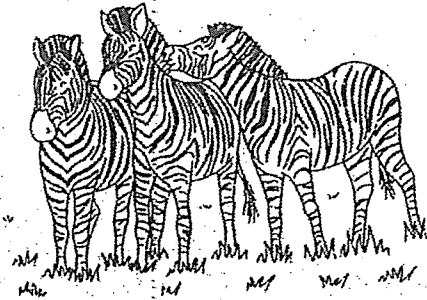

Which of the following is a behavioural adaptation that enables zebras to survive well on grasslands?

- (1) They have stripes that help to camouflage in their surroundings.
- (2) They have broad and flat teeth that helps them grind down their food.
- (3) They have hard hooves to help them run across rocky grounds easily.
- (4) They move around in large groups to make it harder for predators to spot individual zebras.

(Go on to the next page)

3 The diagram below shows the movement of food and water in a plant.

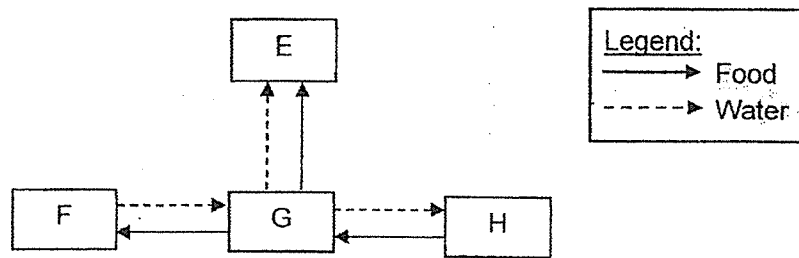

Which one of the following is correct?

	E	F	G	H
(1)	Fruit	Roots	Stem	Leaves
(2)	Leaves	Fruit	Stem	Roots
(3)	Fruit	Stem	Roots	Leaves
(4)	Stem	Roots	Leaves	Fruit

4 Jenny set up the following experiment. She filled a tubing with starch solution and dropped it into a beaker containing iodine solution. Iodine solution turns dark blue in the presence of starch.

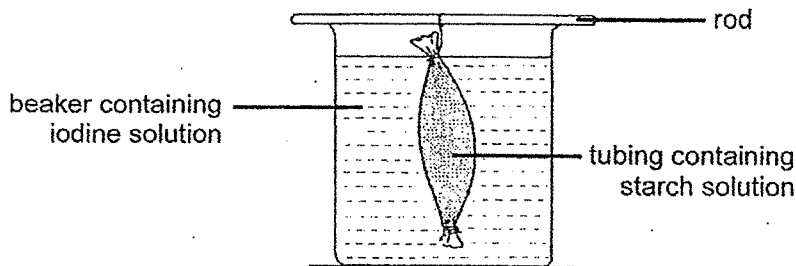

After twenty minutes, she recorded her observations in the table below.

Solution	Colour of Solution	
	Start of Experiment	End of Experiment
Starch solution in the tubing	white	dark blue
Iodine solution in the beaker	yellowish brown	yellowish brown

Based on her observations, which cell part does the tubing represent?

- (1) cell wall
- (2) cytoplasm
- (3) chlorophyll
- (4) cell membrane

(Go on to the next page)

- 5 Diagram 1 below shows the direction of blood flow in some parts of a human body and Diagram 2 shows lungs infected with bacteria. Bacterial infection causes the lungs to perform gaseous exchange less effectively.

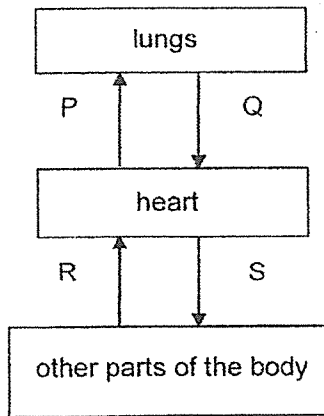

Diagram 1

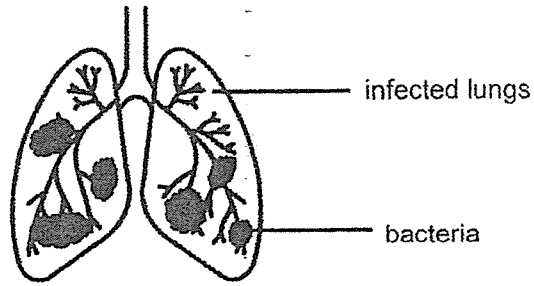
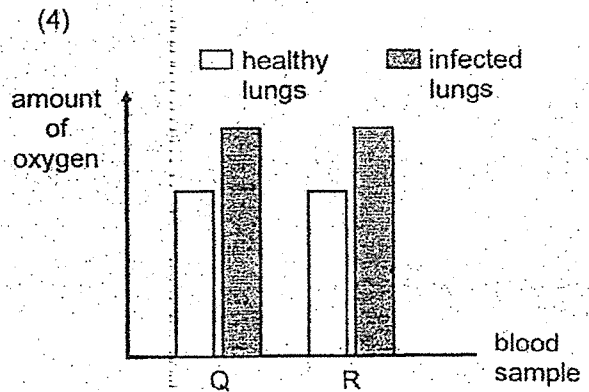
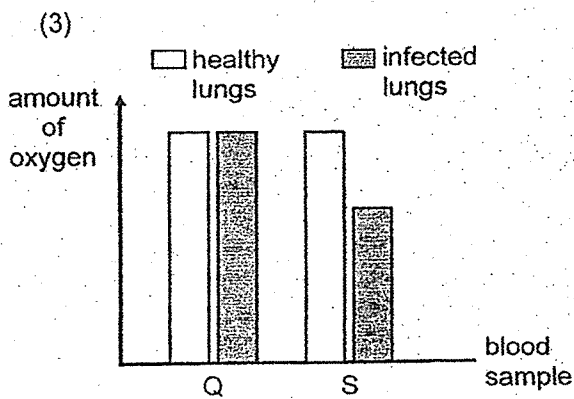
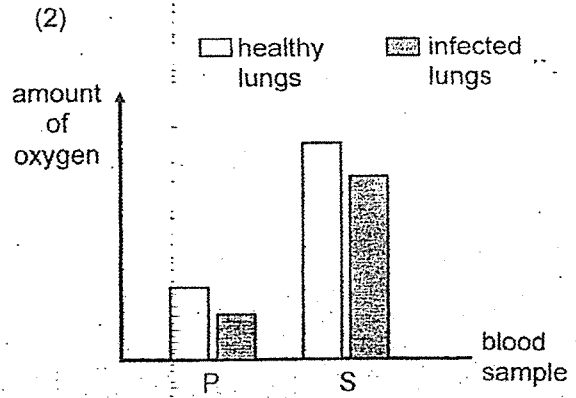
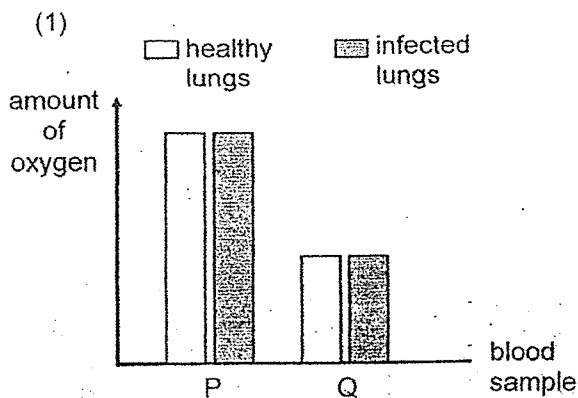

Diagram 2

The same amount of blood was taken from blood vessels P, Q, R and S of an individual with healthy lungs and another with lungs infected with bacteria.

Which chart shows the correct comparison between the amount of oxygen in the blood samples?



(Go on to the next page)

6 The diagram below shows the reproductive systems of a human male, a human female, and a flower.

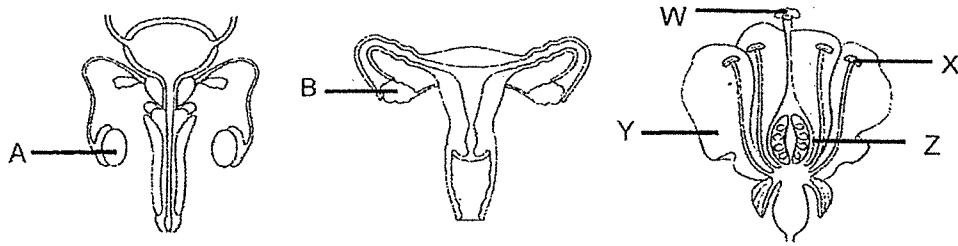

Which of the following represents the parts of the flower which have the same functions as A and B respectively?

	Male part A	Female part B
(1)	X	W
(2)	Z	Y
(3)	X	Z
(4)	W	Z

7 Study the distribution of seeds by plants A, B and C.

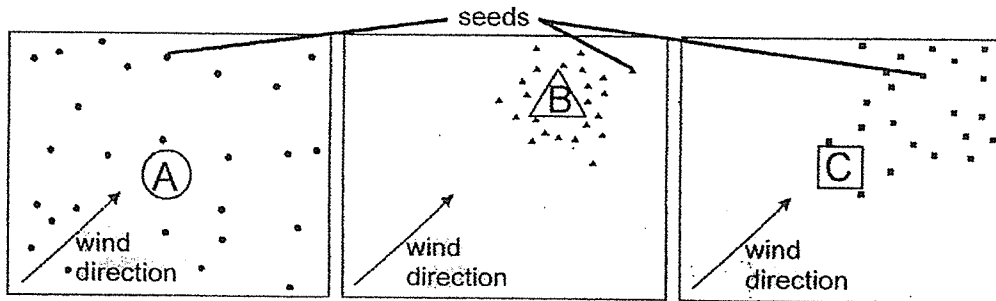

The diagram below shows 3 different kinds of fruits, P, Q and R.

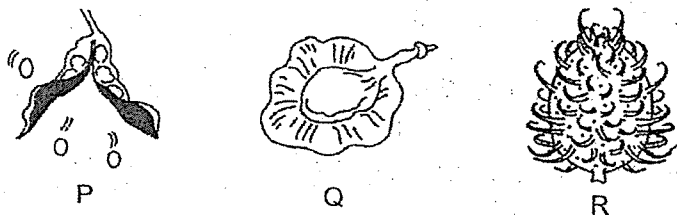

Which one of the following correctly shows which fruits P, Q and R belong to plants A, B and C?

	Plant A	Plant B	Plant C
(1)	P	Q	R
(2)	Q	P	R
(3)	R	Q	P
(4)	R	P	Q

(Go on to the next page)

- 8 The table below provides description of some physical factors in four different habitats, J, K, L and M.

Physical Factors	Habitats			
	J	K	L	M
Amount of moisture in air	Low	Low	High	High
Intensity of light	Low	High	High	Low
Average temperature (°C)	23	18	25	21

An organism Q was observed to have the following characteristics :

- Higher survival rate in a damp environment
- Prefers to stay in a dark environment
- Most active when the surrounding temperature ranges from 20°C to 25°C

In which habitat would there be the greatest number of organism Q?

- (1) J
- (2) K
- (3) L
- (4) M

- 9 The diagrams below show the different types of beaks and feet that birds have to help them survive in different environments.

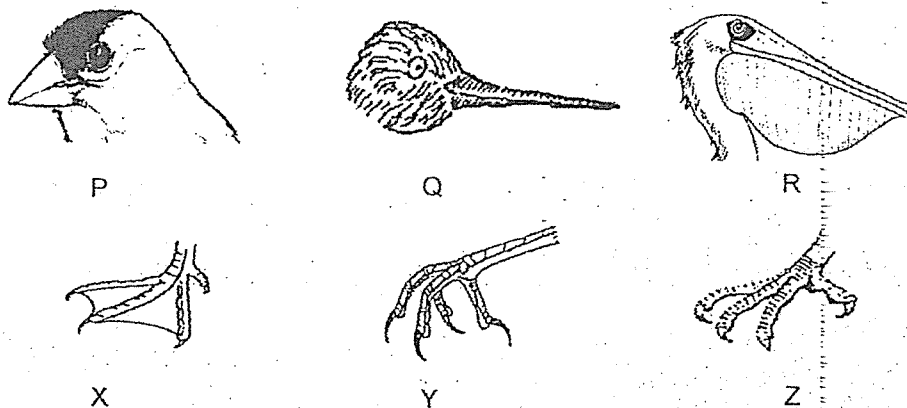

Which one of the following beaks and feet belongs to a bird that can swim fast in water and catch fish in deep waters?

	Beak	Foot
(1)	P	X
(2)	R	Z
(3)	R	X
(4)	Q	Y

(Go on to the next page)

10 L, M, N, O and P are five organisms living together in a habitat.

The table below shows some information about the organisms.

Organisms	Information
L	Has two predators
M	Is the only plant and animal eater
N and O	Have only one food source
P	Is the only food producer

Which one of the following shows a possible food relationship among organisms L, M, N, O and P?

(1)

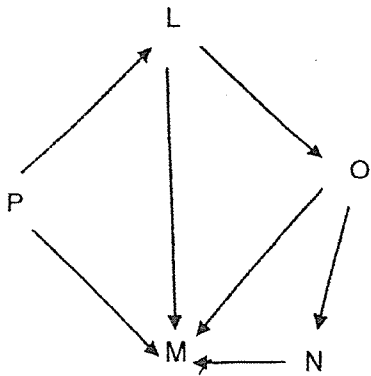

(2)

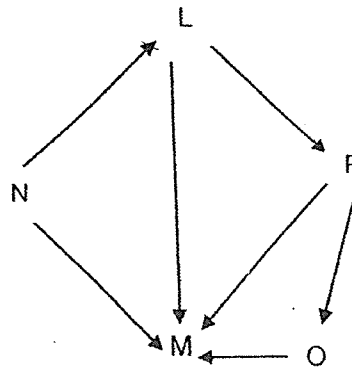

(3)

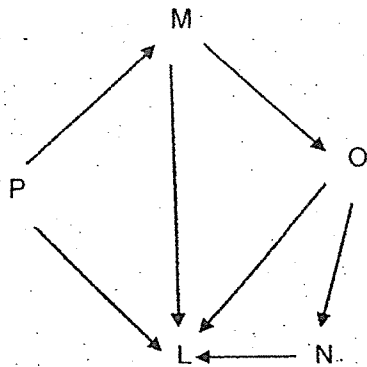

(4)

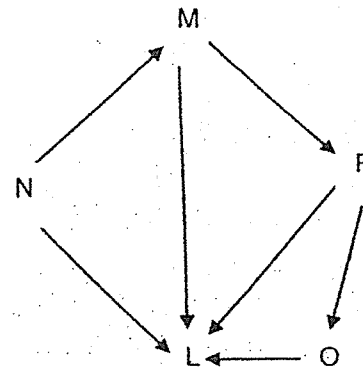

(Go on to the next page)

11 Study the pond habitat below.

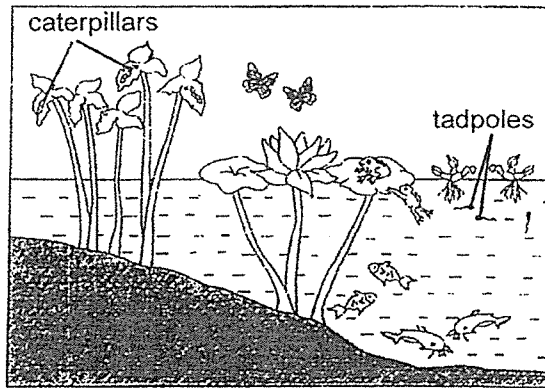

How many populations of producers and consumers can be found in this habitat?

	Number of populations of producers	Number of populations of consumers
(1)	3	4
(2)	3	6
(3)	2	4
(4)	2	6

12 Ahmad conducted an experiment to find out if plants take in water through their roots. He used the set-up as shown below.

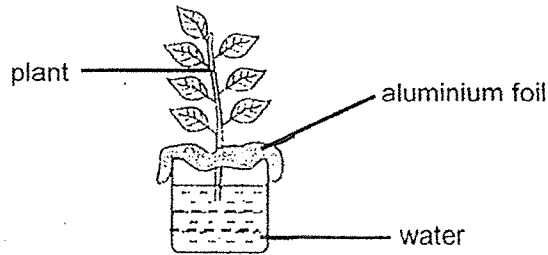

Which other set-up should Ahmad use in his experiment?

(1)

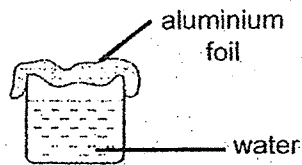

(2)

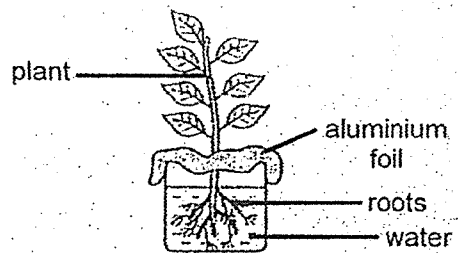

(3)

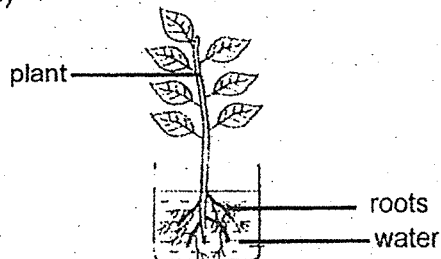

(4)

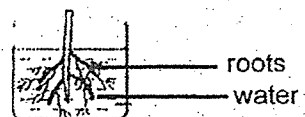

(Go on to the next page)

13 Study the diagram of the human digestive system below.

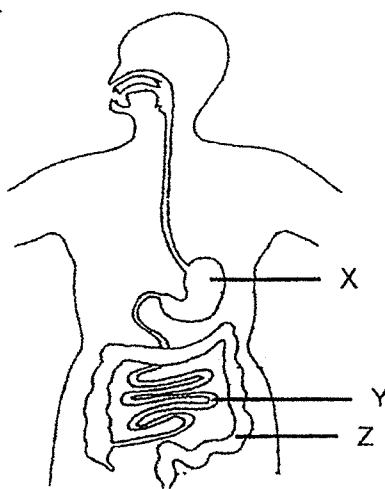

Which of the following correctly shows the functions of the labelled parts X, Y and Z?

	X	Y	Z
(1)	Food is broken down into smaller pieces	Food is mixed with digestive juices	Digested food is absorbed into the bloodstream
(2)	Water is absorbed from the undigested food	Digestion is completed	Food is mixed with digestive juices
(3)	Food is mixed with digestive juices	Digestion is completed	Water is absorbed from the undigested food
(4)	Food is mixed with digestive juices	Digested food is absorbed into the bloodstream	Food is broken down into smaller pieces

(Go on to the next page)

14 Jamie placed a set-up as shown below in a garden.

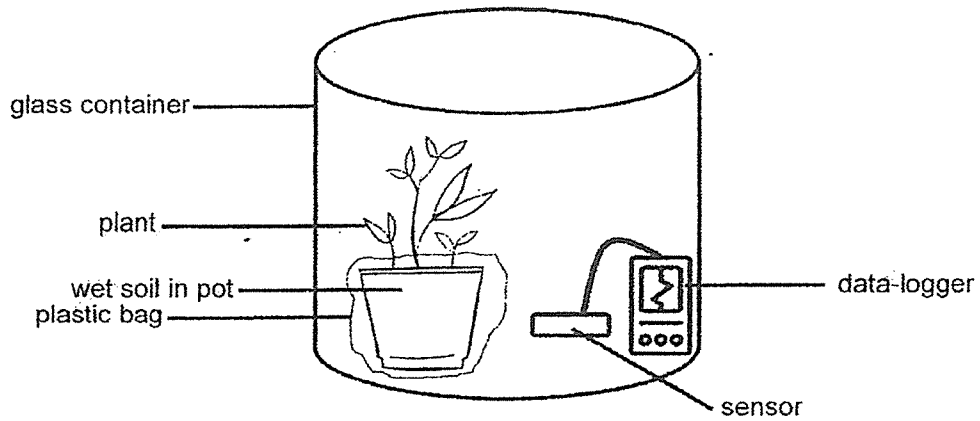

The data-logger detects the amount of carbon dioxide in a sealed glass container over a period of 18 hours.

Which of the following graphs shows the correct representation of the amount of carbon dioxide in the glass container over 18 hours?

(1)

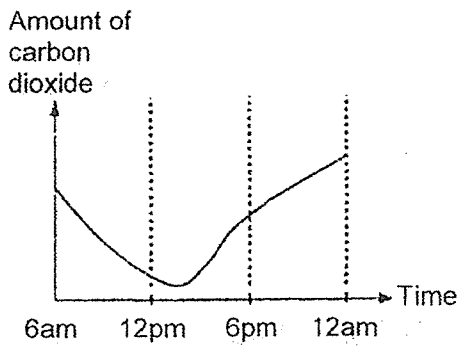

(2)

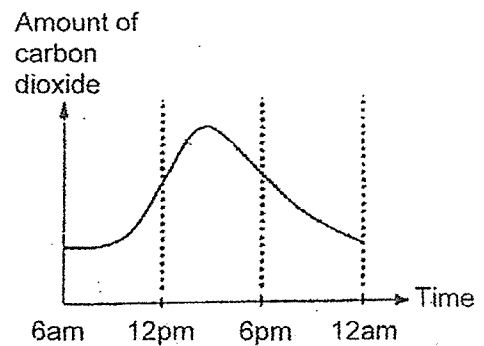

(3)

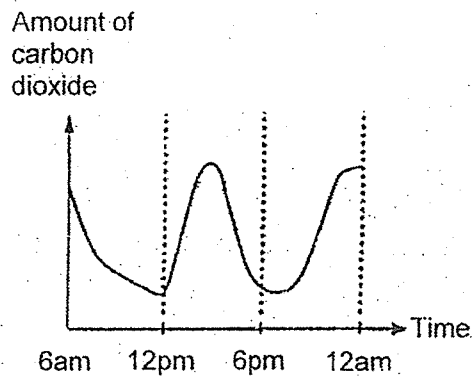

(4)

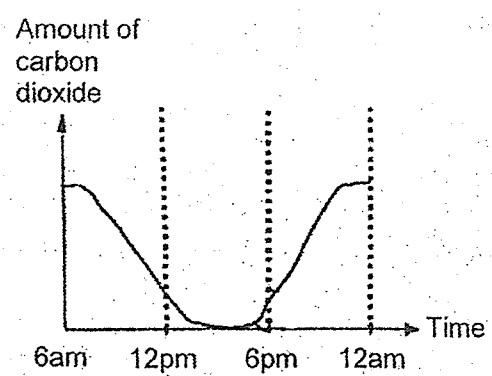

(Go on to the next page)

- 15 The flow chart below shows information on the properties of three different substances, J, K and L.

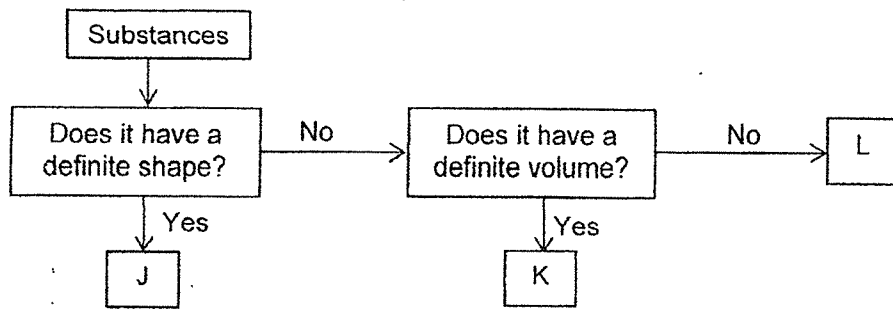

In a container with a capacity of 600 cm^3 (shown below), 200 cm^3 of substance J was placed into the container. Then, 200 cm^3 each of substance K and L were pumped into the container.

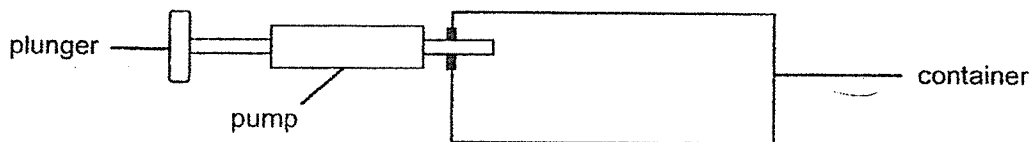

Finally, an additional 100 cm^3 of substance K was pumped into the container. Which of the following shows the final volume of each substance in the container?

	Volume of substance (cm^3)		
	J	K	L
(1)	100	200	300
(2)	200	200	100
(3)	200	300	100
(4)	200	300	200

- 16 Henry set up the experiment below in a dark room.

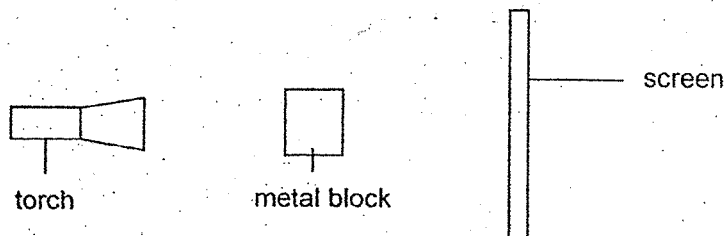

He observed that the height of the shadow cast by the metal block on the screen increased when he moved an object.

What did Henry change in the experiment?

- (1) He moved the screen nearer to the torch.
- (2) He moved the metal block nearer to the screen.
- (3) He moved the torch further from the metal block.
- (4) He moved the screen further from the metal block.

(Go on to the next page)

- 17 Ashraf left a beaker of water on a table. After a few minutes, he observed water droplets forming on the inner surface of the beaker as shown in the diagram below.

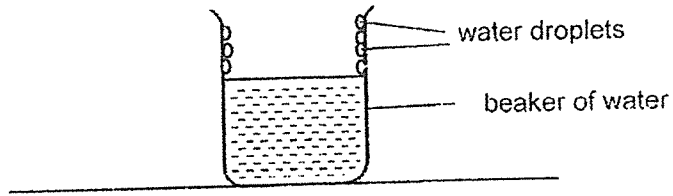

Which one of the following graphs shows the temperature of the water in the beaker over time?

(1)

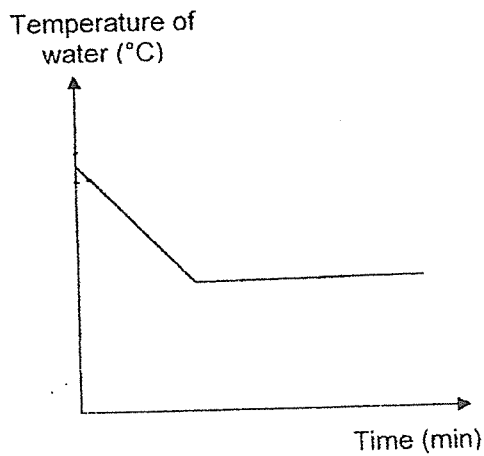

(2)

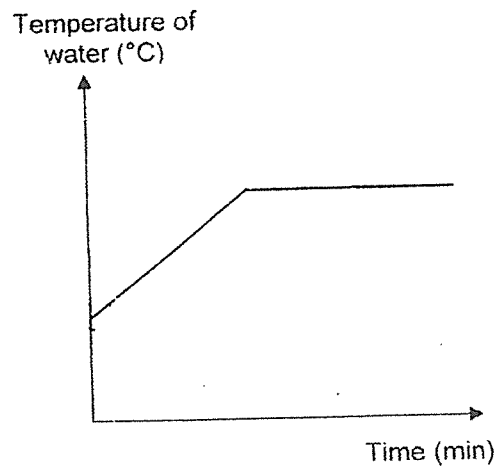

(3)

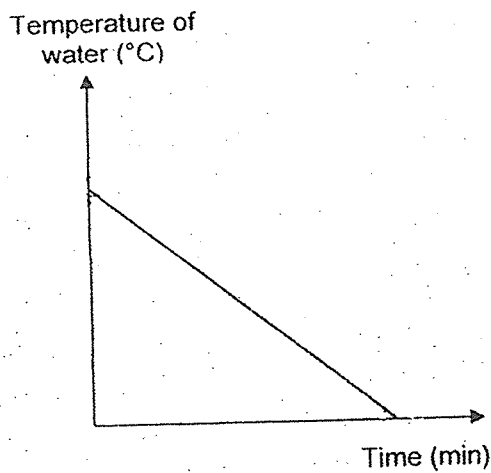

(4)

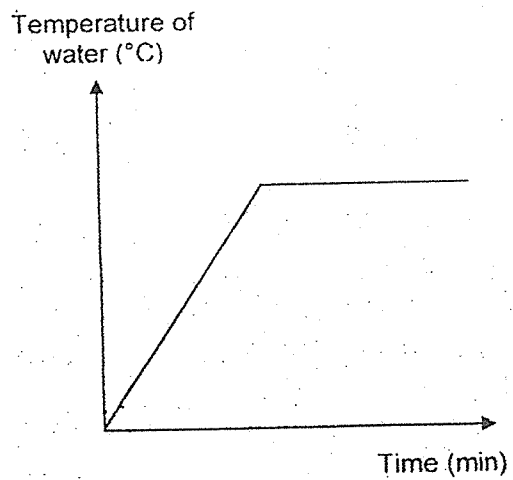

(Go on to the next page)

- 18 Taylor conducted an experiment using metal blocks W and X. At the start of the experiment, she placed block X in contact with block W in three different set-ups in the same room at 30°C. The temperature of each block at the start is shown below.

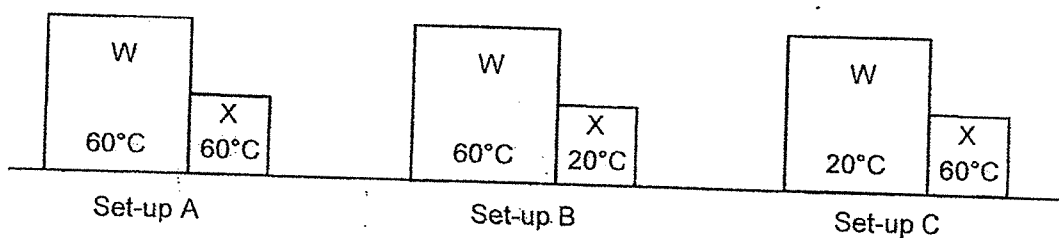

In which set-up(s) would the temperature of block X increase immediately after being placed next to block W?

- (1) B only
 - (2) C only
 - (3) A and B only
 - (4) A and C only
- 19 The table below shows the freezing and boiling points of four different substances, A, B, C and D.

Substances	Freezing point (°C)	Boiling point (°C)
A	44	299
B	0	100
C	53	174
D	80	218

Three students made the following statements.

- Ivy: At 50°C, only substance B is in the solid state.
 Kamal: At 90°C, all the substances exist in the liquid state.
 Samy: When heated from 60°C to 200°C, substances B, C and D undergo a change in state.

Whose statement(s) is/are correct?

- (1) Samy only
- (2) Kamal only
- (3) Ivy and Samy only
- (4) Kamal and Samy only

(Go on to the next page)

- 20 Jing Jing pulled down the plunger of a device and after she released it, the ball moved upwards as shown below.

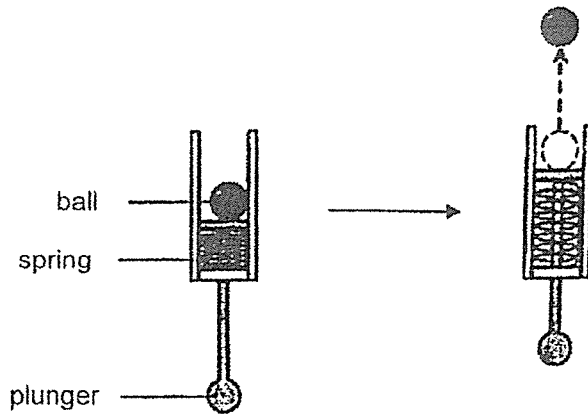

Which of the following will enable the ball to move a greater distance?

- A Use a less elastic spring
 - B Use a ball with a smaller mass
 - C Decrease the distance that the plunger is pulled
- (1) A and B only
 (2) A and C only
 (3) B and C only
 (4) A, B and C

- 21 Tristan sets up two circuits, F and G, as shown in the diagrams below. In each circuit, there is an aluminium rod, a plastic rod and a wooden rod.

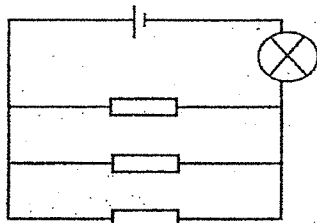

circuit F

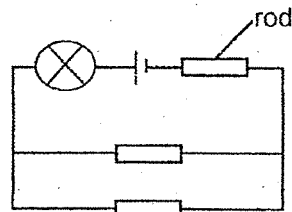

circuit G

In which circuit will the bulb light up?

- (1) F only
- (2) G only
- (3) F and G
- (4) None of the circuits

(Go on to the next page)

- 22 Jane had two balls, X and Y, of the same size but of different masses as shown below.



She conducted an experiment using the set-up below. When each ball was released from the top of ramp A, it rolled down and hit the marble which rolled up ramp B and hit the bell, causing it to sound.

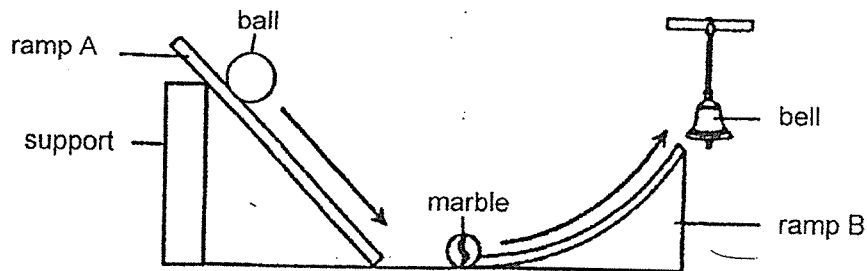

Which ball would cause the bell to sound the loudest and why?

	Ball	Reason
(1)	X	It has a smaller mass so it produced less friction.
(2)	Y	It has a greater mass so it has more potential energy to be converted to more kinetic energy.
(3)	Y	It has a greater mass so it produced more friction.
(4)	X	It has a smaller mass so less gravitational force is acting on it.

(Go on to the next page)

- 23 Suresh conducted an experiment whereby he placed a plastic block at the top of a ramp. The block slid down to point Z and then to the end of the ramp as shown in the diagram below.

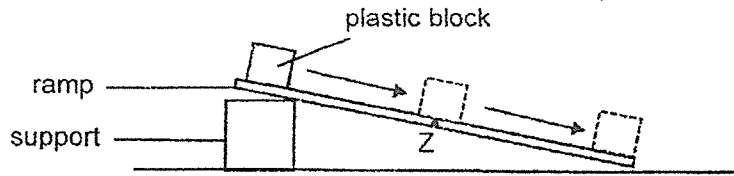

The table below shows the amount of each type of energy the block has at point Z.

Amount of energy (unit)		
Kinetic	Heat	Potential
350	150	350

Suresh spread oil evenly on the surface of the ramp and repeated the experiment using the same block. Which of the following best represents the amount of each type of energy at point Z?

	Amount of energy (unit)		
	Kinetic	Heat	Potential
(1)	400	100	250
(2)	400	100	350
(3)	300	200	350
(4)	350	200	250

- 24 A ball was dropped from the top of a support. The diagram below shows the path of the ball as it moved from point A to B then to C and finally D.

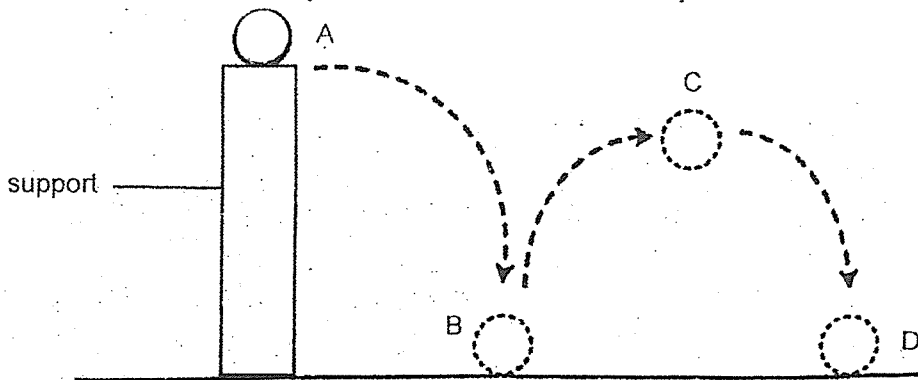

At which point(s) was gravitational force acting on the ball?

- (1) A only
- (2) A and C only
- (3) B, C and D only
- (4) A, B, C and D

(Go on to the next page)

- 25 Jennifer conducted an experiment whereby she applied a force on block W as shown in the diagram below. She recorded the distance moved by the block before stopping.

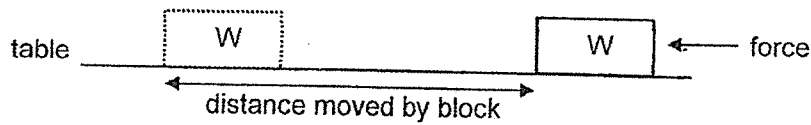

She repeated the experiment using other blocks made of the same material but of different masses and area of contact with the table. The results are recorded in the table below.

Block	Mass (g)	Area of contact with the table (cm ²)	Distance moved (cm)
W	80	200	12
X	100	200	8
Y	100	90	8
Z	120	90	5

Based on her results, which of the following statement(s) is/are correct?

- A The greater the mass of the block, the more friction between the block and table.
- B The greater the area of contact of the block with the table, the less friction between the block and table.
- C The area of contact of the block with the table does not affect the amount of friction between the block and table.
- (1) A only
- (2) A and C only
- (3) B and C only
- (4) A, B and C

- 26 Ethan placed magnet P at 10 cm away from a paper clip. He moved the magnet slowly towards the paper clip and observed that magnet P moved 5 cm before attracting the paper clip as shown below.

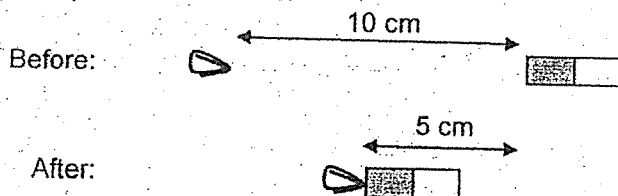

He repeated the experiment with magnets Q and R and recorded his observations in the table below.

Magnet	Distance moved by magnet before it attracted the paper clip (cm)
P	5
Q	2
R	8

(Go on to the next page)

Ethan hung a steel weight on a spring balance and placed magnet P below the set-up. He observed that the weight moved towards magnet P. He measured the extension of the spring and removed magnet P. He repeated the experiment with magnets Q and R and observed that the weight moved towards them.

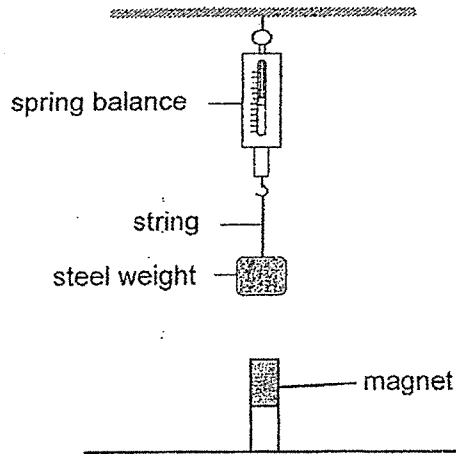

Which one of the following graphs correctly shows the extension of the spring when magnets P, Q and R were placed under the set-up?

(1)

Extension of the spring (cm)

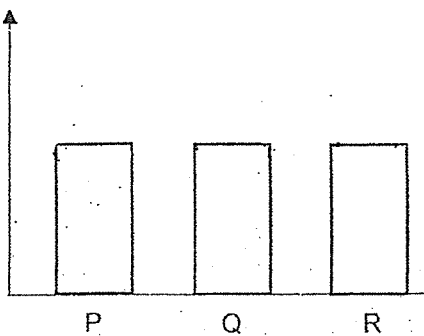

(2)

Extension of the spring (cm)

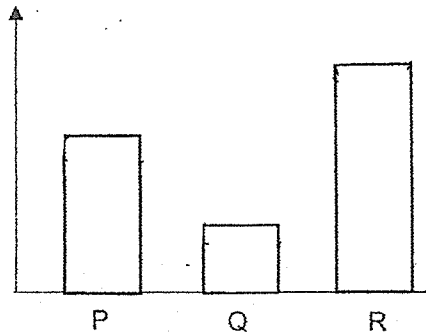

(3)

Extension of the spring (cm)

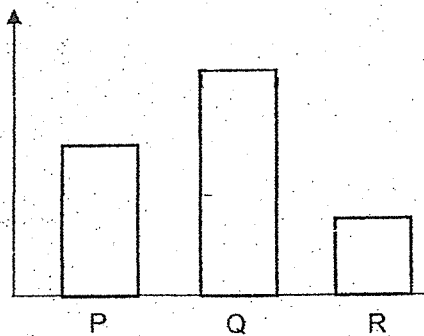

(4)

Extension of the spring (cm)

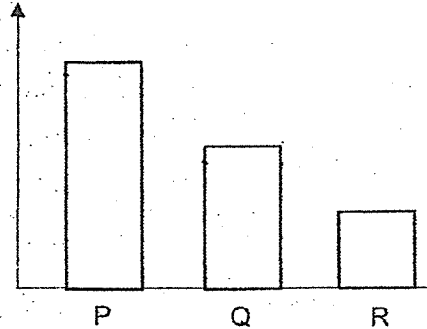

(Go on to the next page)

27 Xinyi has a toy train that works on batteries. It has two switches, X and Y.

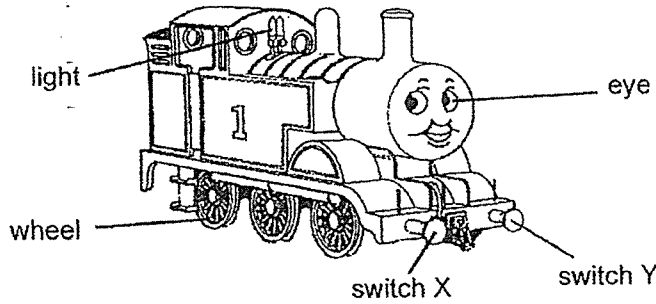

She recorded her observations of the train in the table below when the switch(es) is/are turned on.

Switch on	Eyes	Wheels	Light
X only	did not move	did not move	turned on
Y only	moved	moved	did not turn on
Both X and Y	moved	moved	turned on

Based on her observations, which one of the following electric circuits is correct?

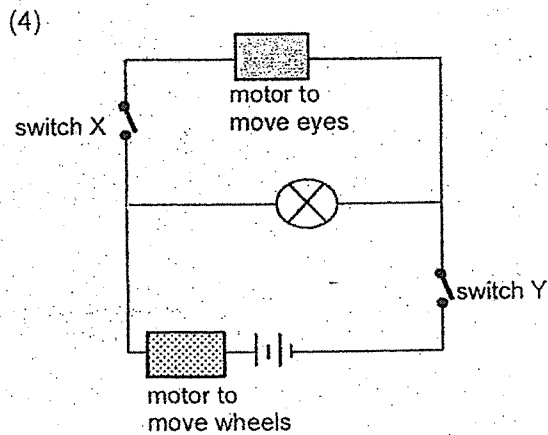
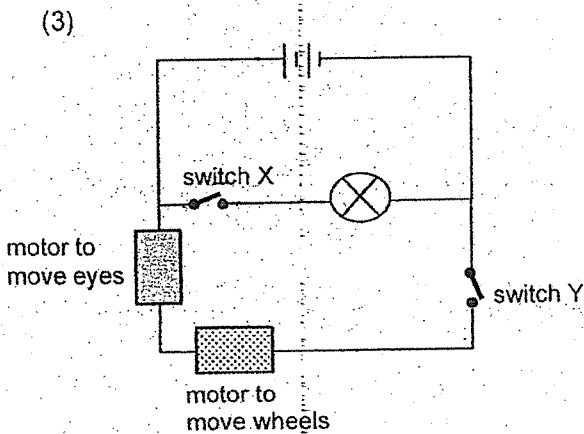
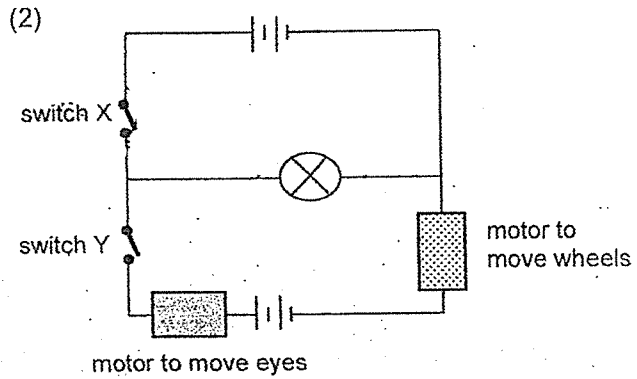
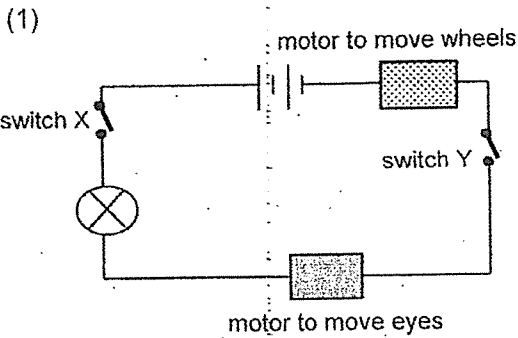

(Go on to the next page)

- 28 Eng Tat set up four electric circuits, W, X, Y and Z, represented by the circuit diagrams below. All the batteries and bulbs used are identical and in working condition.

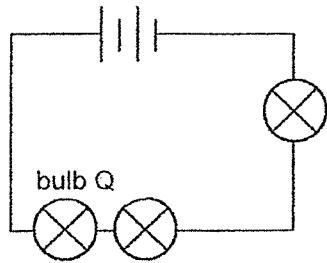

Circuit W

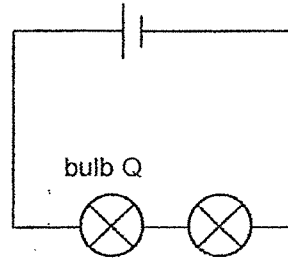

Circuit X

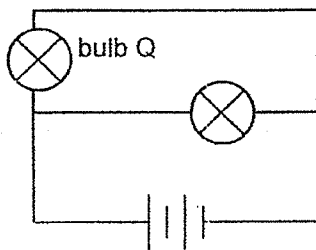

Circuit Y

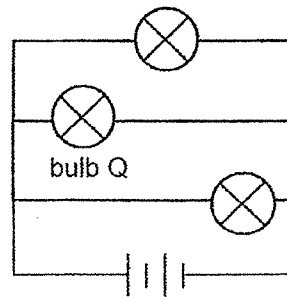

Circuit Z

Which two circuits should Eng Tat compare to find out if adding more bulbs in parallel will affect the brightness of bulb Q?

- (1) W and X
- (2) W and Z
- (3) X and Y
- (4) Y and Z

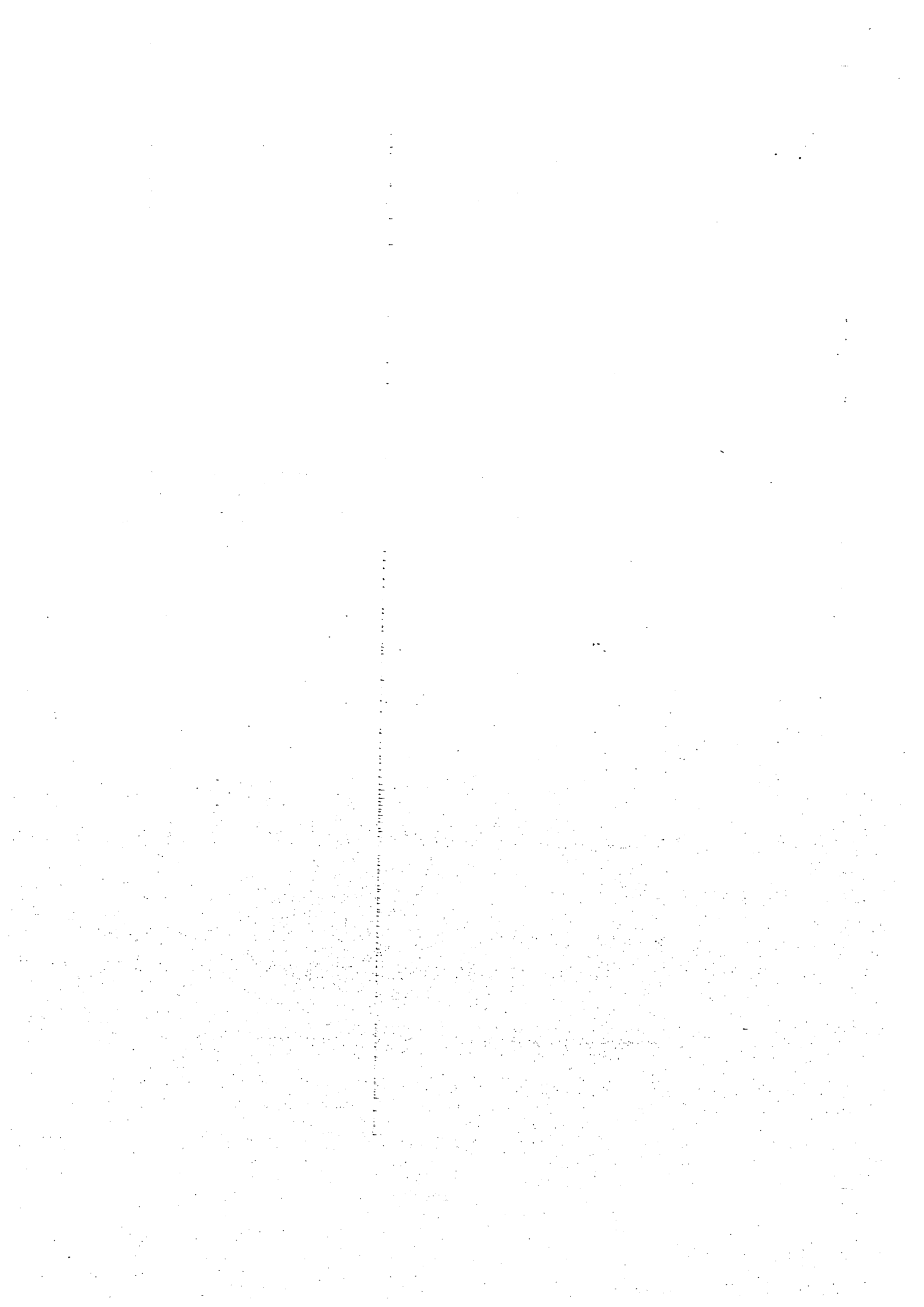

METHODIST GIRLS' SCHOOL

Founded in 1887



PRELIMINARY EXAMINATION 2023
PRIMARY 6
SCIENCE

BOOKLET B

Total Time for Booklets A and B: 1 hour 45 minutes

INSTRUCTIONS TO CANDIDATES

Do not turn over this page until you are told to do so.

Follow all instructions carefully.

Answer all questions.

Name: _____ ()

Class: Primary 6: _____

Date : 23 August 2023

Booklet A	56
Booklet B	44
Total 	100
Parent's Signature	

This booklet consists of 14 printed pages including this page.

For questions 29 to 40, write your answers in the spaces provided. The number of marks available is shown in brackets [] at the end of each question or part question. [44 marks]

- 29 A farmer recorded the average amount of daylight hours in her farm growing plant Z over six months. The table below shows her results.

Month	Feb	Mar	Apr	May	Jun	Jul
Average Amount of Daylight hours (h)	8	9	10	10	11	12

- (a) In which month(s) would plant Z produce the sweetest fruits? Explain your answer. [2]

- (b) When harvesting the fruits, the farmer will often bury the fruits which are half eaten by insects under plant Z. Explain how this benefits plant Z. [2]

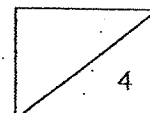

- 30 *Aedes* mosquitoes can spread Zika virus. The diagram below shows the life cycle of an *Aedes* mosquito.

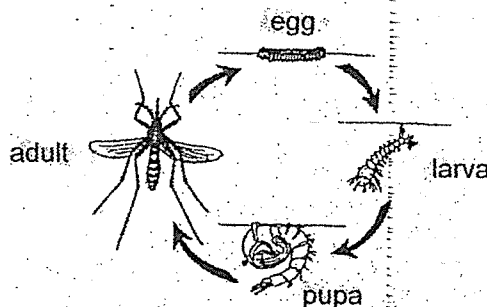

Jillian studied the life cycle of the *Aedes* mosquitoes at different temperatures of water. The results of her observations are shown below:

	Duration of stages in water at different temperatures (days)			
	25°C	27°C	29°C	31°C
Egg	2	2	2	2
Larva	10	8	6	4
Pupa	2	2	2	2

(Go on to the next page)

- (a) Based on Jillian's results, explain how global warming will affect how fast Zika virus spread. [2]

- (b) The spread of Zika virus and infection depends on the seasonal variation of the climate of a country. Graphs A and B below show the number of Zika cases in country X for a period of one year.

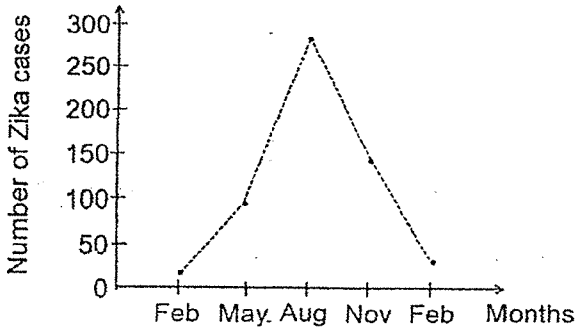

Graph A

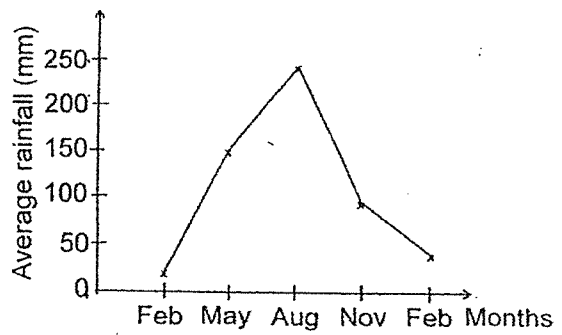

Graph B

- (i) State the relationship between the average amount of rainfall and the number of Zika cases from May to August. [1]

- (ii) Explain the relationship observed in (b)(i). [1]

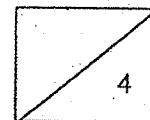

(Go on to the next page)

- 31 Raja conducted an experiment by removing an outer ring from the stem of a fruit tree as shown below.

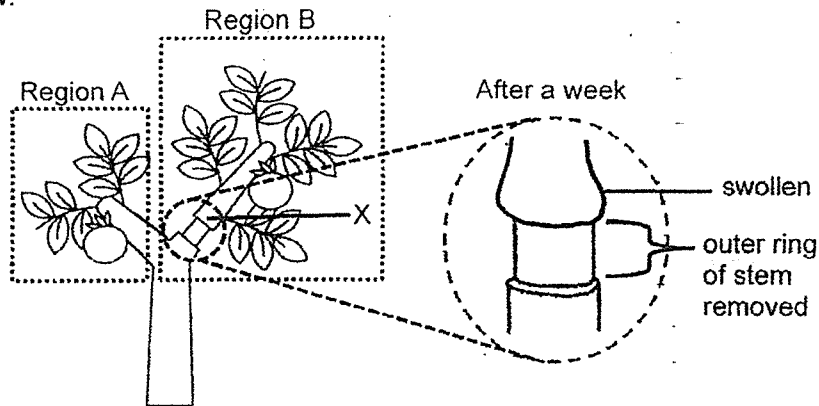

- (a) Raja observed that part X was swollen after a week. Give a reason for this observation. [1]

- (b) Raja observed that bigger fruits were produced in region B after he removed the outer ring of the stem of his fruit trees. Explain why. [1]

- (c) Farmer Tan advised Raja not to remove the outer ring of the stem of his fruit trees completely around the stem from end to end, but to remove the outer ring in a C-shaped manner as shown in the diagram below.

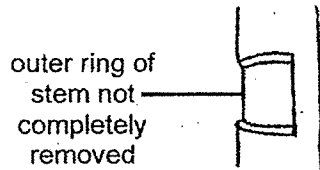

- Explain how farmer Tan's advice to Raja is better for the growth of the fruit trees. [2]

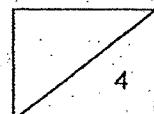

(Go on to the next page)

- 32 Animal L lives in shallow streams. It has gills to obtain oxygen in water and has lungs to breathe in oxygen on land.

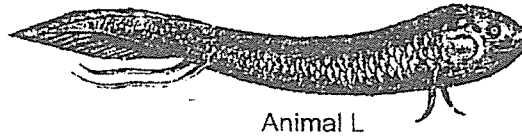

Animal L

During the hot and dry season, animal L burrows into mud at the bottom of dried-up streams, covers itself in a mucus 'cocoon' which traps moisture and goes into deep sleep as shown in the diagram below.

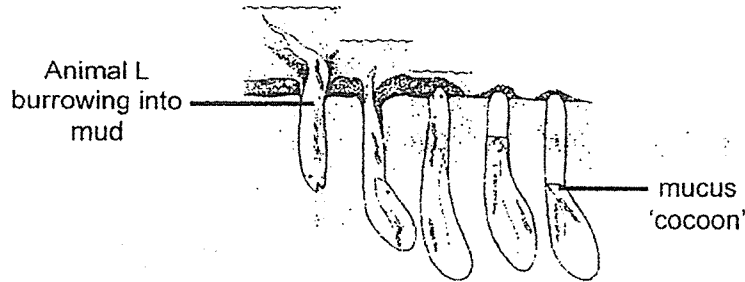

- (a) State two physical factors of the environment which will affect the survival of animal L. [1]

- (b) Explain why having a streamlined body helps animal L to survive in its natural environment. [1]

- (c) Explain how covering itself in a mucus 'cocoon' helps animal L increase its chances of survival during the hot and dry season. [1]

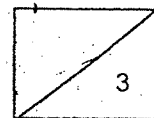

(Go on to the next page)

33 Jessi wanted to find out if light is required for the germination of seeds. She placed two set-ups, P and Q, in the Science room as shown below.

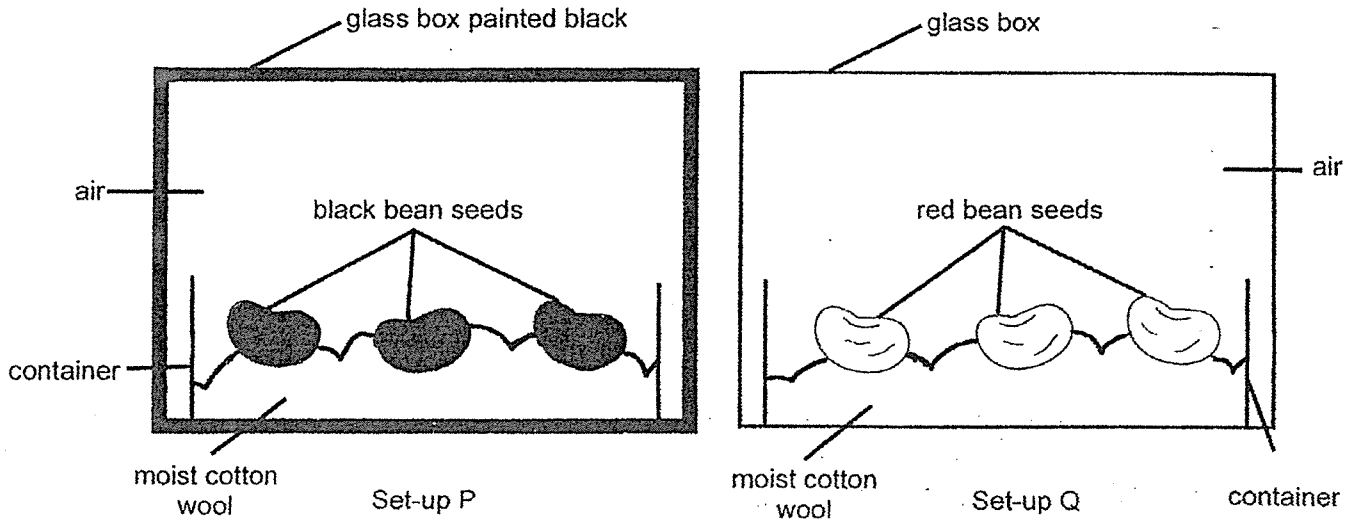

(a) Did Jessi conduct a fair experiment? Explain your answer. [1]

(b) Next, Jessi wanted to find out if water is required for germination. Other than the change that Jessi made to set-up Q below, draw and label two other changes to ensure a fair test between set-ups P and Q. [1]

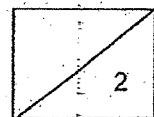
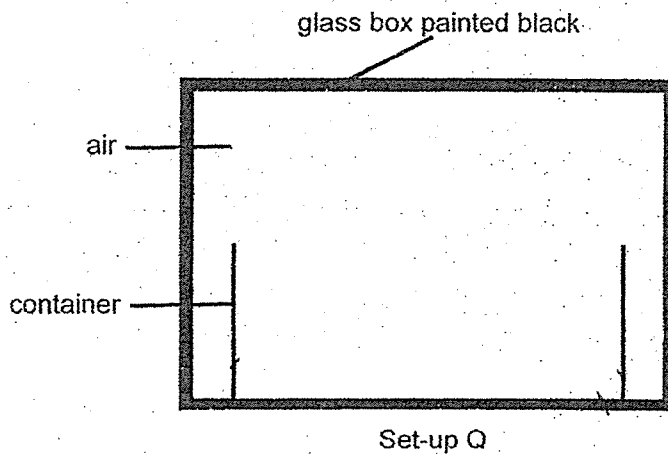

(Go on to the next page)

- 34 The diagram below shows the cutting down of a large number of trees in a forest.

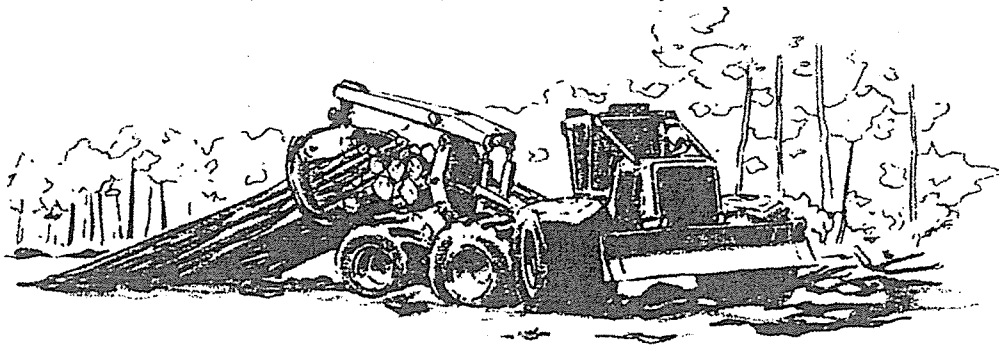

- (a) Explain how the above activity will affect fully submerged plants in the rivers nearby during periods of heavy rain. [2]

The food web below shows the relationship between some organisms that live in the forest.

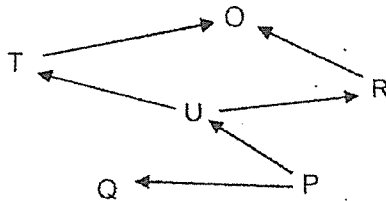

When the trees were cut down, it caused the population of U to decrease sharply.

- (b) Explain how the decrease in the population of organism U will affect the population of organism O. [2]

- (c) Explain how cutting down a large number of trees can lead to an increase in the Earth's temperature. [1]

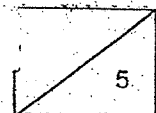

(Go on to the next page)

- 35 Tony conducted an investigation to find out which method of hanging his wet towels would allow them to dry the fastest. He soaked three identical towels, P, Q and R, into the same amount of water and folded towel Q into half and towel R three times before hanging them up to dry as shown in the diagram below.

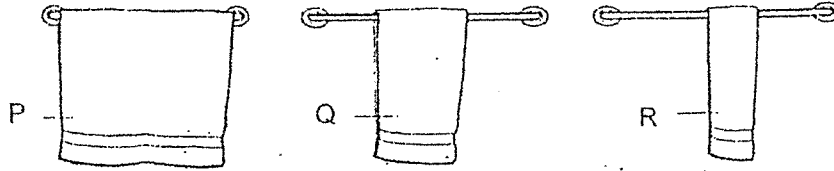

- (a) State a possible hypothesis that Tony was trying to test. [1]

- (b) Which towel will dry the slowest? Explain why. [1]

After a hot shower, Tony could not see his reflection clearly in the bathroom mirror as the mirror surface had become misty.

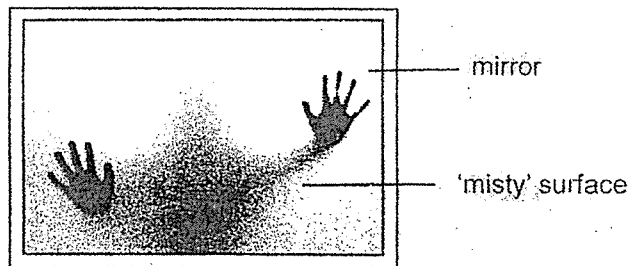

- (c) Explain how the mist formed on the mirror. [2]

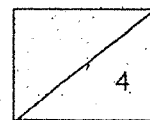

(Go on to the next page)

36 Joe wanted to make chocolates as shown below.



He heated some solid cocoa butter using set-ups W and X as shown below. In set-up W, the pan is placed in a pot filled with water. In set-up X, the pan is placed directly on the heating plate. The heating plates can reach a temperature of 180°C .

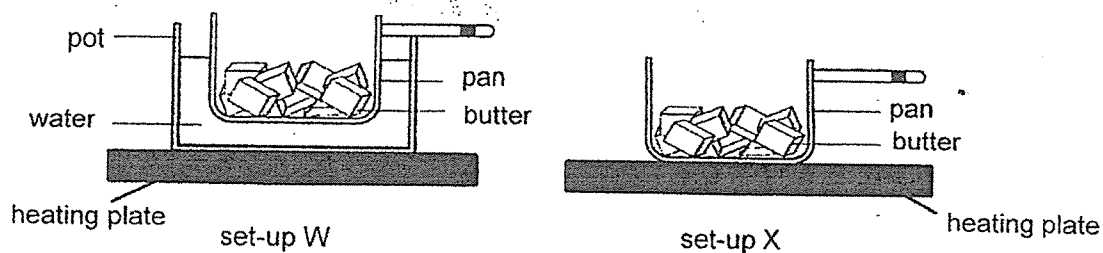

After switching on the heating plate for some time, Joe observed that the butter in set-up W melted without burning but the butter in set-up X melted and became burnt. Joe's father told him that butter will burn when heated beyond 170°C .

(a)(i) Based on the information above, explain why the butter in set-up W did not burn. [1]

(ii) Joe poured the melted butter in set-up W into a mould as shown in the diagram below.

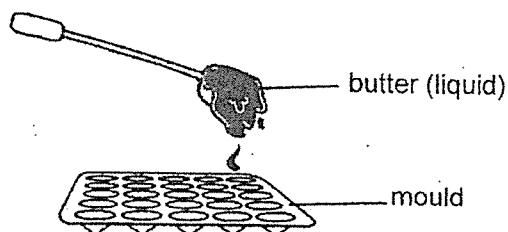

Explain why the butter has to be in liquid state before he can pour them into the mould. [1]

(Go on to the next page)

- (b) Joe replaced the heating plate in set-up W with another one made of the same material as shown in the diagram below.

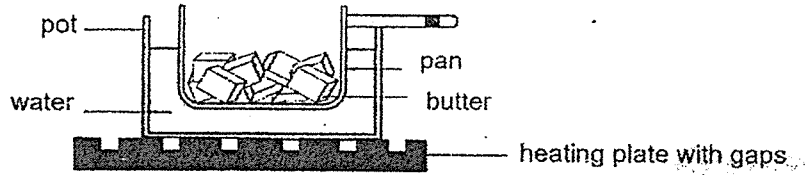

Compared to set-up W earlier, would the butter now take a longer or shorter time to melt? Explain why. [1]

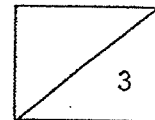

- 37 Anna wanted to install a ceiling fan with a light in her living room.

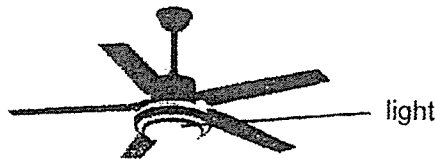

The fan comes with two switches, S1 and S2, that allow her to turn the fan on with or without light as described in the table below. Each switch can be turned on to position A or B in the circuit.

S1	S2	Fan is turned on	Light is turned on
A	A	yes	yes
A	B	no	no
B	A	no	no
B	B	yes	no

- (a) The diagram shows part of the circuit. Complete the circuit so that it will work as described. [2]

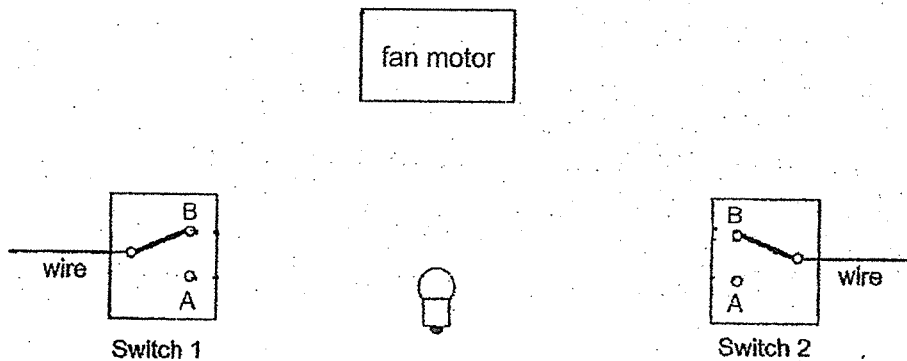

(Go on to the next page)

- (b) Anna set up another two electrical circuits, Y and Z, with different bulb arrangements. She added a bulb to each circuit and recorded the brightness of the bulbs in a graph as shown below.

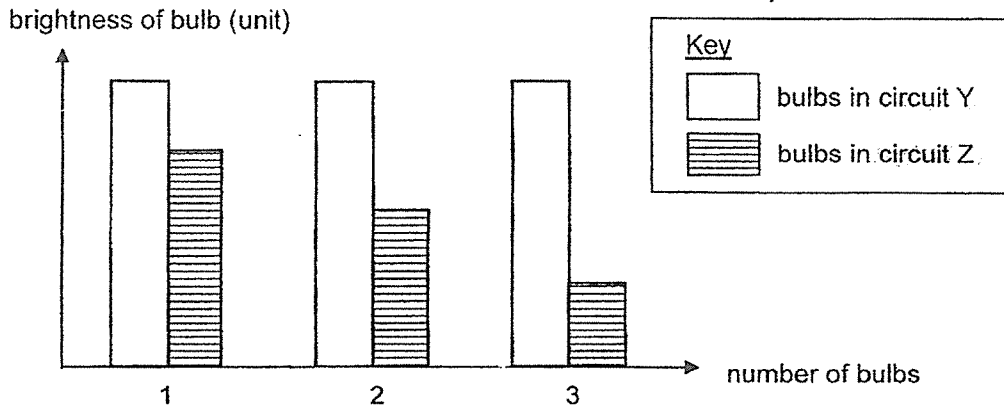

- (i) Based on the above information, state the arrangement of bulbs for each circuit. [1]

Circuit Y: _____

Circuit Z: _____

- (ii) Besides changing the number and arrangement of bulbs, suggest what Anna can do to increase the brightness of the bulbs in circuit Z. Explain your answer. [2]

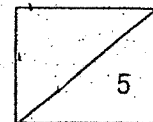

(Go on to the next page)

- 38 Sophie conducted an experiment using the set-up below. She added blocks under a ramp made of material A until the metal cube started to slide down the ramp.

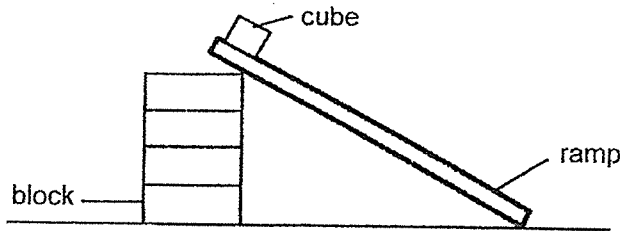

She repeated the experiment using similar ramps made of materials B and C and recorded her observations in the table below.

Material	Number of blocks needed before the cube slides down the ramp
A	4
B	2
C	7

- (a) Identify the force that acts against the cube as it slides down the ramp. [1]

The diagram below shows a trolley on a traveller and a magnified view of a trolley's wheel on part of a traveller.

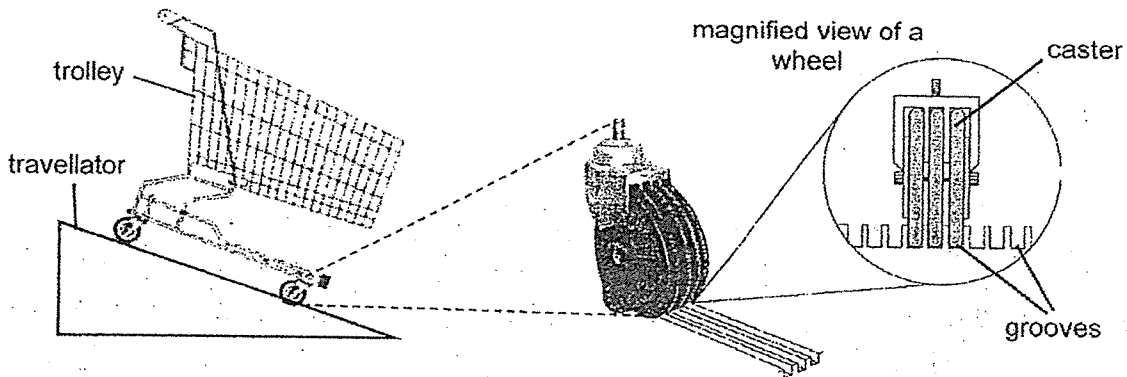

When the trolley is on the traveller, the casters fit into the grooves of the traveller to prevent the trolley from sliding down the traveller.

- (b) Based on the results in Sophie's experiment, which material, A, B or C, is most suitable for making the wheels of the trolley so that a moving trolley can come to a stop in the shortest period of time? Explain your answer. [2]

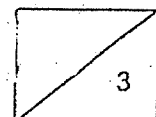

(Go on to the next page)

- 39 Ali designed and made a toy car. When the back wheels of the car are moved backwards, the rod will turn and the non-elastic string will coil around the rod, pulling the metal spring, as shown in the diagram below. After he released the car, it will move forward.

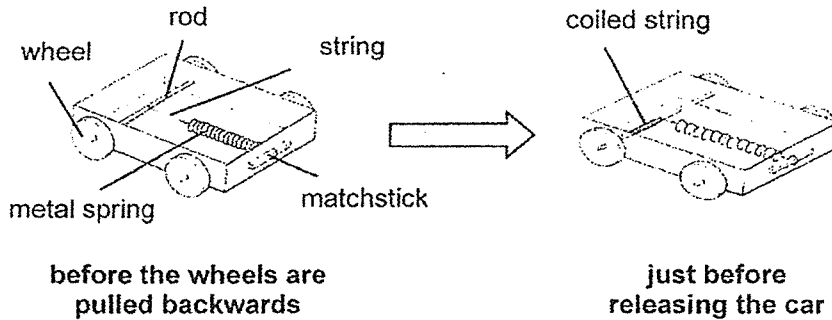

- (a) Fill in the boxes with the forms of energy as Ali moved the car backwards and then released it, allowing the car to move a distance before it stops. [2]

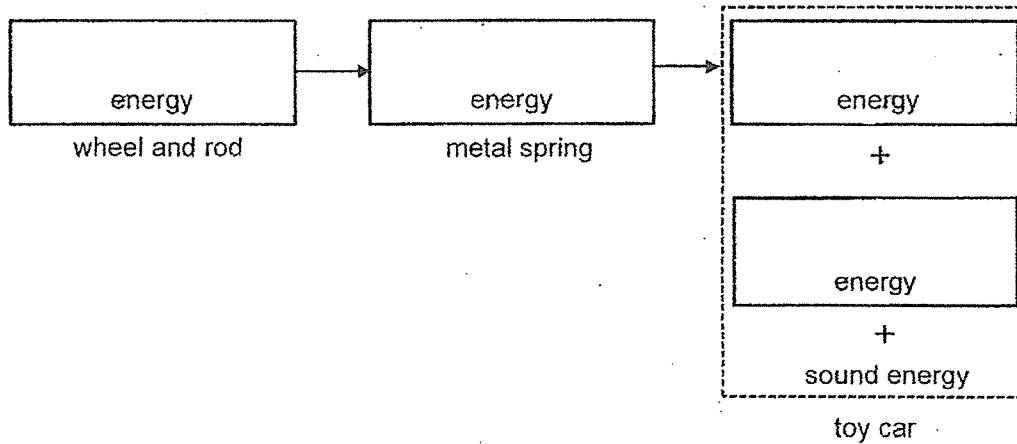

- (b) If Ali increases the distance moved backwards by the car, what will happen to the distance travelled by the car? Explain your answer in terms of energy conversion. [2]

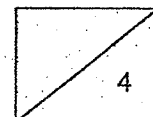

(Go on to the next page)

- 40 The diagrams below show the side and front views of a modified carnival toy. The objective of the game is to hit the platform with a hammer as hard as possible so that the puck will be propelled upwards along the groove to hit the bell at the top of the tower.

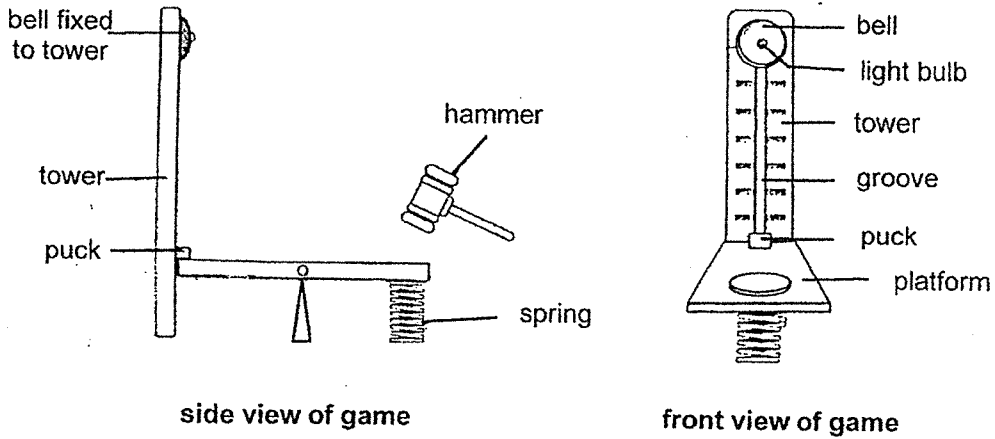

- (a) Without changing the height of the tower and amount of force applied on the platform, suggest a way to make it easier for the same puck to hit the bell. [1]

When the puck hits the bell, the light bulb in the centre of the bell will also light up. The electric circuit inside the bell is shown in the diagram below.

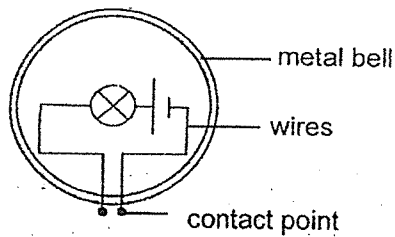

- (b) Suggest a physical property of the material that the puck is made of so that the bulb can light up. [1]

- (c) Explain how the bulb lights up when the puck hits the bell. [1]

MG 8 (8A2)

01.3	11.1	21.1
02.4	12.2	22.2
03.1	13.3	23.2
04.4	14.1	24.4
05.2	15.3	25.2
06.3	16.4	26.3
07.4	17.1	27.3
08.4	18.1	28.4
09.3	19.4	
10.1	20.1	

**Methodist Girls' School (Primary) P6 Sci
Prelim 2023 Answer Key**

Booklet B

Qn	Suggested Answers
29a	July. Plant Z received the most light in July to undergo the fastest/highest rate of photosynthesis to produce the most amount of food/sugar/glucose.
29b	Decomposers break down the (rotting) fruits into simple/simpler substances which return to the soil as mineral salts and can be used as fertilisers for plant Z to grow healthily.
30a	Global warming will cause the temperature of water to rise/increase which shorten the total duration of stages in the life cycle of Aedes mosquito / reduce the time taken for the eggs to hatch and develop into adults faster, resulting in the faster spread of Zika virus.
30bi	As the (average) amount of rainfall increases, the number of Zika cases also increases.
30bii	The increased amount of rainfall resulted in an increased amount of (stagnant) water/breeding grounds where female mosquitoes can lay their eggs, so there are more adult mosquitoes to spread the virus.
31a	Food made in the leaves could not be transported to the other parts (of the plant) below X as the food-carrying tubes were removed.
31b	Food-carrying tubes were removed so more food was transported to the fruits above X / region B.
31c	If the outer ring of the stem was completely removed around the stem, food made in the leaves (during photosynthesis) cannot be transported to the roots which affects the ability to absorb water and mineral salts (for the plant) needed for the plant to make food.
32a	Any two points: Temperature of surroundings / water / mud Amount of moisture / water Amount of air / oxygen / sunlight
32b	Streamlined body (reduces water resistance due to friction), allows animal L to swim faster/ more easily/ swim easier to escape from predators/ look for food/ catch its prey.
32c	Any one of the following: Animal L loses less water/ can conserve water Animal L gains heat (from the surroundings) at a slower rate Animal L gains less heat (from the surroundings)
33a	No, she should use the same type of bean seeds as the only variable she should change is the presence / absence of light.
33b	Draw and label 3 black bean seeds and dry cotton wool.
34a	There will be less roots to hold the soil which will be eroded into the river during heavy rain. The fully submerged plants will receive less light which decreases the rate of photosynthesis and the population size will decrease.
34b	A decrease in population of organism U will cause the population of organisms R and T to decrease due to less food. Organism O which prey on organisms R and T will also decrease in population.

**Methodist Girls' School (Primary) P6 Sci
Prelim 2023 Answer Key**

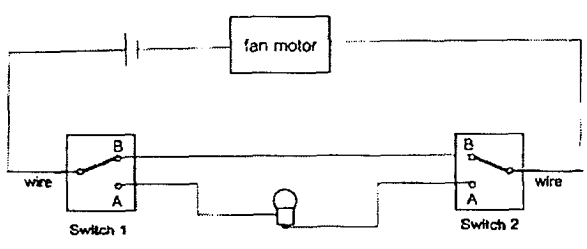
34c	There will be fewer trees to take in carbon dioxide during photosynthesis so more carbon dioxide in the air will trap more heat on Earth, leading to an increase in temperature.
35a	The greater the surface area of the towel exposed to the surrounding, the faster the rate of evaporation.
35b	Towel R. It has the least surface area exposed to the surrounding so the rate of evaporation of water is the slowest.
35c	Warmer water vapour in the surrounding came into contact with the cooler surface of the mirror and condensed into water droplets, forming the mist.
36ai	The boiling point of water (100°C) is lower than the temperature (170°C) at which butter burns.
36aii	Liquid cocoa butter does not have a definite shape and takes the shape of the mould.
36b	Longer time. The surface area of the heating plate in contact with the pot is less so the butter takes a longer time to gain heat and melt.
37a	
37bi	Circuit Y: Parallel Circuit Z: Series
37bii	Add more batteries to the circuit. More electric current can flow through the circuit for the bulbs to be brighter.
38a	Frictional force.
38b	Material C. The most number of blocks are required on material C before the cube slides down the ramp. There is greatest friction between the wheels and the ground, allowing the trolley to stop faster.
39a	<u>kinetic</u> energy → <u>(elastic) potential</u> energy → <u>kinetic</u> energy + <u>heat</u> energy + sound
39b	The car will travel a longer distance. When he increases the distance moved backwards by the car, the wheel/rod has more kinetic energy which is converted to more (elastic) potential energy of the metal spring, and converted to more kinetic energy of the car.
40a	Use a more elastic spring.
40b	Conductor of electricity
40c	When the metal puck comes into contact with the contact points, the circuit is closed and electric current flows through the wires to the bulb, causing it to light up.