

CATHOLIC HIGH SCHOOL
PRELIMINARY EXAMINATION (2023)
PRIMARY SIX
SCIENCE
BOOKLET A

Name: _____ ()

Class: Primary 6 - _____

Date: 24 August 2023

28 questions

56 marks

Total Time for Booklets A and B: 1 hour 45 minutes

INSTRUCTIONS TO CANDIDATES

Do not turn over this page until you are told to do so.

Follow all instructions carefully.

Answer all questions.

Shade your answers in the Optical Answer Sheet (OAS) provided.

This booklet consists of 24 printed pages, excluding the cover page.

Booklet A (28 × 2 marks)

For each question from 1 to 28, four options are given. One of them is the correct answer. Make your choice (1, 2, 3 or 4). Shade your answer on the Optical Answer Sheet. (56 marks)

1 Which of the following is/are correct about reptiles and mammals?

	Reptiles	Mammals
A	no legs	have legs
B	have dry scaly skin	have hair
C	breathe through lungs	breathe through lungs
D	give birth to live young	lay eggs

- (1) B only
- (2) A and D only
- (3) B and C only
- (4) A, C and D only

2 Some people were trapped in the lift when it broke down.

What would happen to the volume of various gases in the lift after half an hour?

	Oxygen	Carbon Dioxide	Water Vapour
(1)	increased	decreased	increased
(2)	increased	decreased	decreased
(3)	decreased	increased	increased
(4)	decreased	increased	decreased

3 Study the diagram.

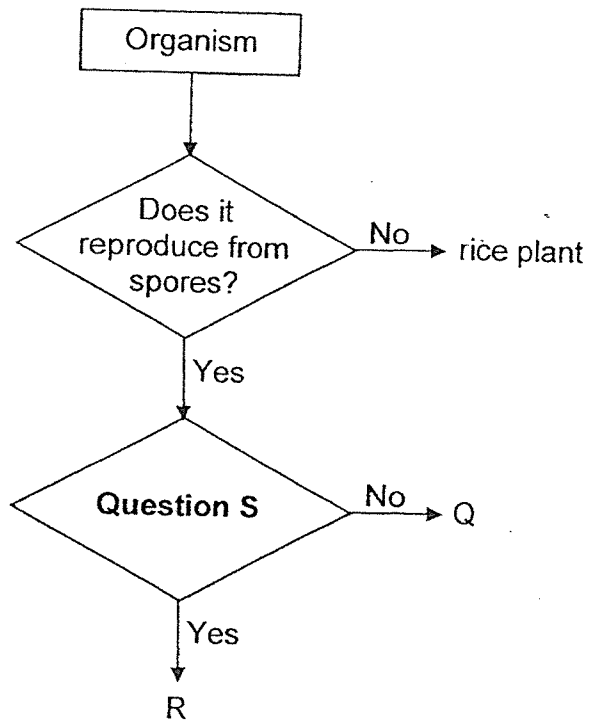

Organism T is a mushroom which can be represented by Q or R.



Which of the following best represents S and T?

	Question S	Organism T
(1)	Is it microscopic?	Q is a non-flowering plant.
(2)	Is it a decomposer?	R contains chlorophyll.
(3)	Does it make its own food?	Q bears flowers.
(4)	Does it feed on dead matter?	R does not bear fruits.

- 4 The graph shows the amount of digestive juices released by different parts of the digestive system.

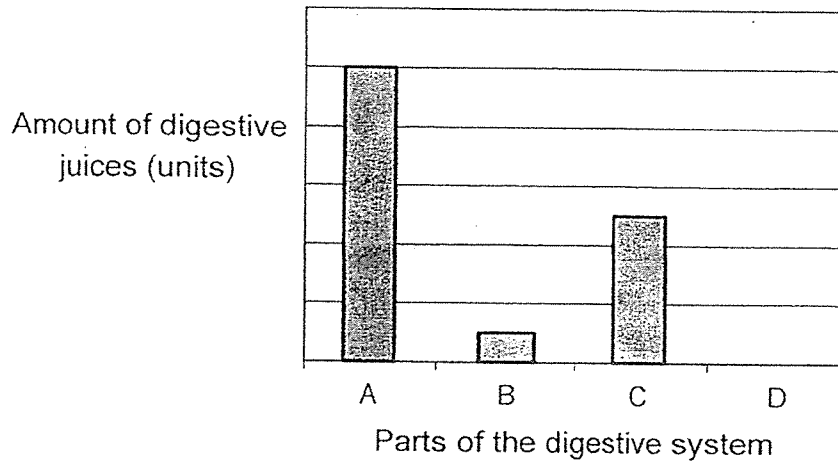

Based on the graph, which of the following shows the percentages of undigested and digested food in the different parts of the digestive system?

Key

- digested food
- undigested food

(1)

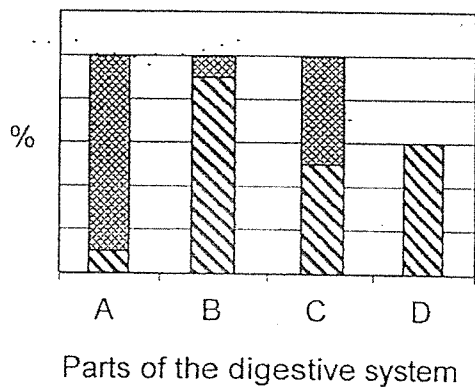

(2)

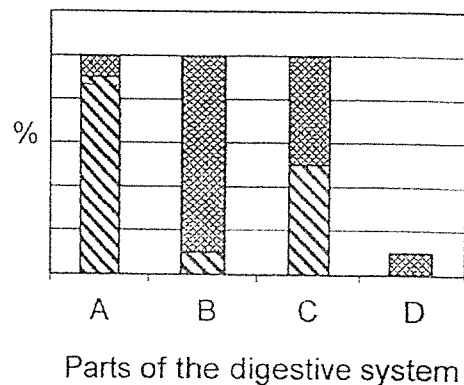

(3)

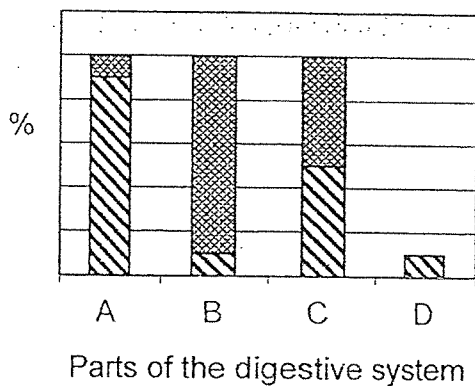

(4)

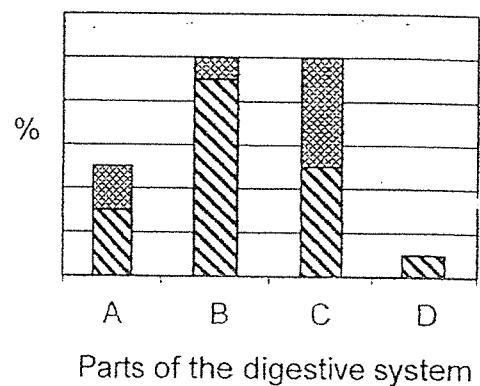

- 5 Samantha covered the stem and all parts of the leaves of a plant with clear oil. She placed the plant in a sunny area and watered it daily. She observed the plant after a week.

Which statement is correct?

- (1) The plant died because it could not absorb light.
- (2) The plant survived because it could still absorb light.
- (3) The plant survived because it could still take in water.
- (4) The plant died because it could not take in and release gases.

- 6 The diagrams show a plant cell and an animal cell.

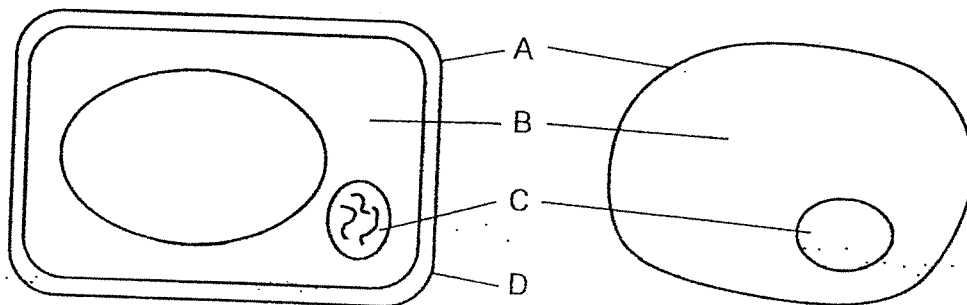

Cell Part	Function
A	gives the cell a definite shape
B	allows activities to take place in the cell
C	contains genetic information
D	supports the cell

Which cell parts are correctly matched to its function?

- (1) A and B only
- (2) C and D only
- (3) A, B and D only
- (4) B, C and D only

- 7 Sara set up an experiment as shown. She covered three similar leaves in different types of plastic bags. The plastic bags were of the same size. She left the plant under the sun for a few hours.

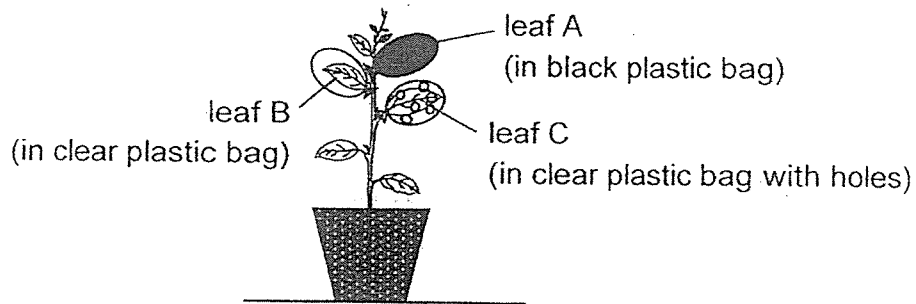

Which graph represents the amount of oxygen produced by leaves A, B and C in each plastic bag after several hours?

(1)

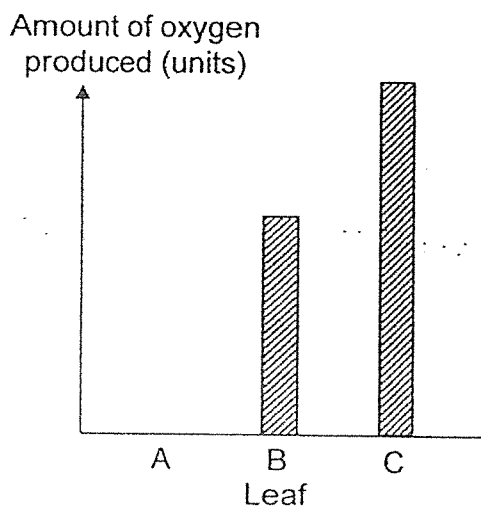

(2)

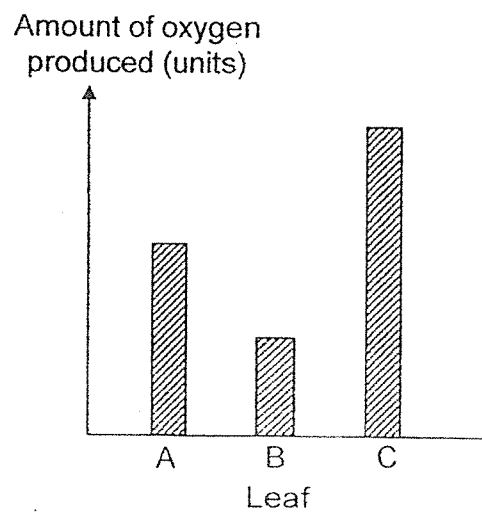

(3)

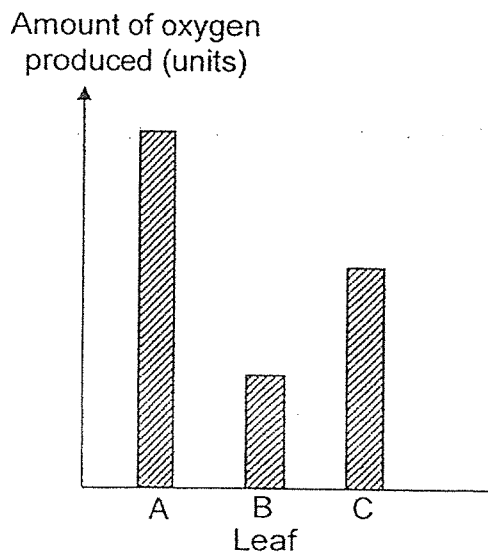

(4)

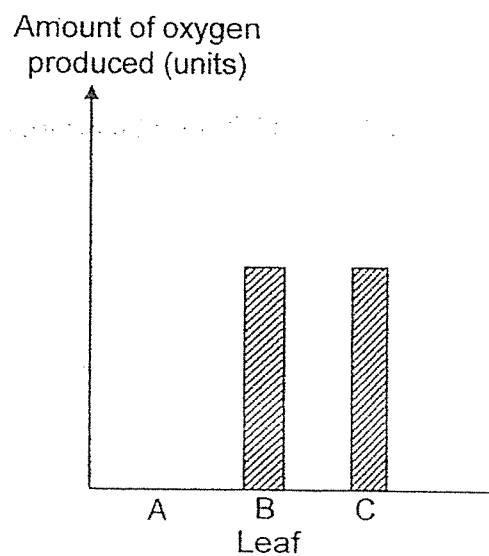

- 8 The diagram shows the life cycle of a flowering plant.

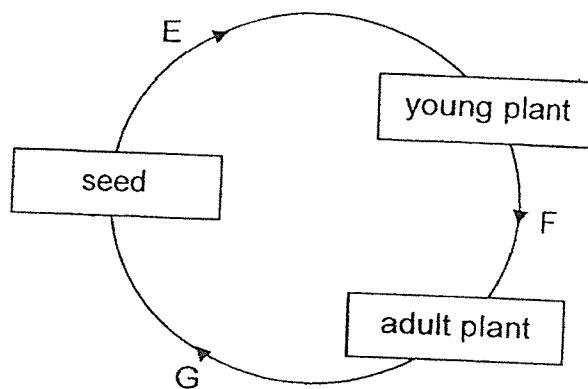

Which statement is correct?

- (1) Pollination takes place at F.
 - (2) The flower develops into a fruit at G.
 - (3) Sunlight is needed for germination at E.
 - (4) The seeds of the fruit are dispersed at F.
- 9 Which characteristics help a fruit to be dispersed by water?

- A It has air spaces.
- B It is sweet and juicy.
- C It does not allow water to go through.

- (1) A and B only
- (2) A and C only
- (3) B and C only
- (4) A, B and C

10 The diagram shows the life cycle of an insect.

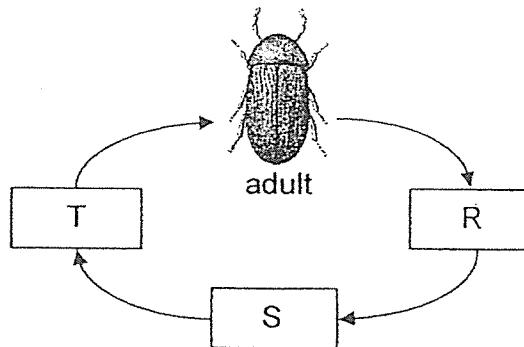

The table shows the number of days the insect spent at each of the stages, R, S, T and adult, when it is exposed to different surrounding temperatures.

Stage	Number of days spent at each stage				
	20 °C	25 °C	30 °C	35 °C	40 °C
R	22	16	10	5	12
S	35	27	20	14	11
T	12	7	4	4	8
adult	46	37	25	18	18

Which statement(s) can be inferred from the results?

- A The insect does not feed at stage R.
- B Its eggs can withstand more heat than the other stages.
- C As the surrounding temperature increases, the number of days spent at stage S decreases.
- D The duration of one complete life cycle decreases when exposed to increased surrounding temperatures.

- (1) C only
- (2) A and C only
- (3) B and D only
- (4) A, B and D only

- 11 John conducted an experiment on photosynthesis in a dark room using the set-up as shown. He measured the amount of gas collected in the measuring cylinder after some time.

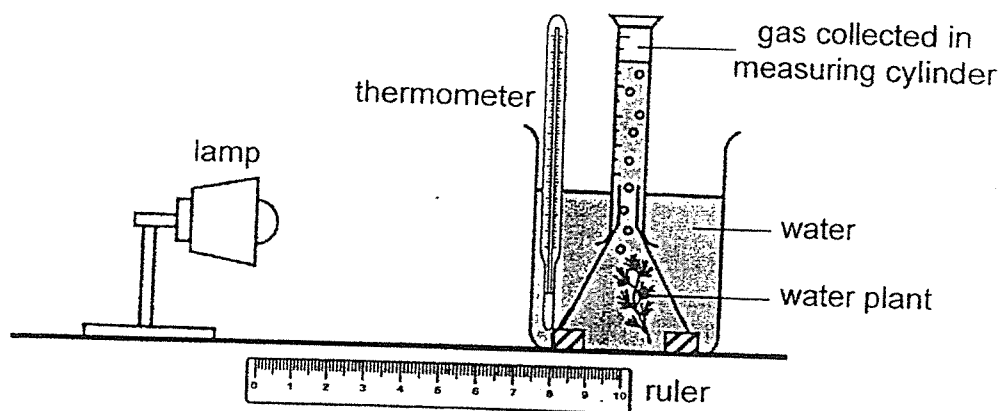

John repeated his experiment by increasing variable X and keeping all other variables the same. His results are as shown.

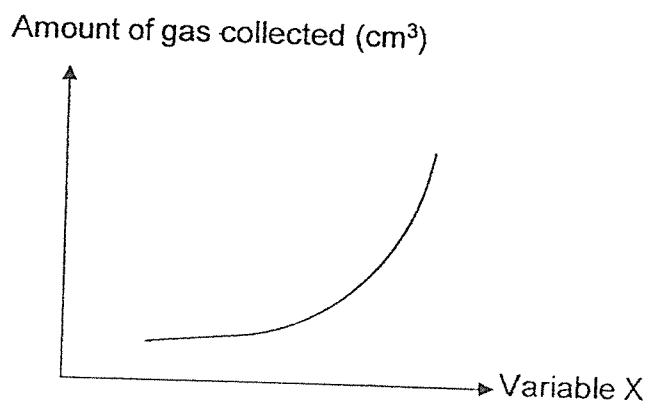

What could variable X be?

- A temperature of water
- B light intensity of the lamp
- C amount of carbon dioxide in the water
- D distance between the water plant and the lamp

- (1) D only
- (2) A, B and C only
- (3) A, C and D only
- (4) A, B, C and D

12 The diagram shows a tree with different organisms living on it.

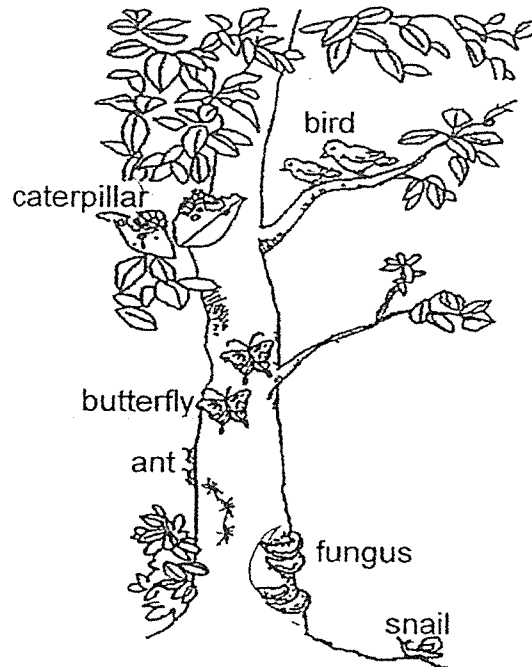

Which statements are correct?

- A There are five populations of organisms.
- B There are four populations of organisms.
- C The fungi form one population of plants on the tree.
- D All the organisms and the tree form one community.

- (1) A and C only
- (2) A and D only
- (3) B and D only
- (4) B, C and D only

13 Study the diagram of fish F.

Its two eyes are visible from the top when it lies motionless and buried in sand, in wait for its prey. The colour of its spots changes when it swims to different surroundings.

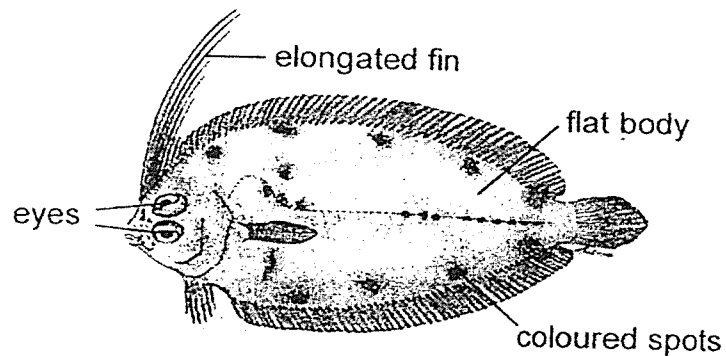

top view of fish F

Which of the following identifies the structural and behavioural adaptations that prevent fish F from being easily spotted by its prey?

	Structural adaptation	Behavioural adaptation
(1)	Its body is flat.	It buries itself in the sand.
(2)	It remains motionless on the sea floor.	Its spots change colour to blend with its surroundings.
(3)	Both eyes are on the top side of the body.	It remains motionless on the sea floor.
(4)	It has an elongated fin which can be seen from a distance.	Its spots change colour to blend with its surroundings.

14 Study the food web.

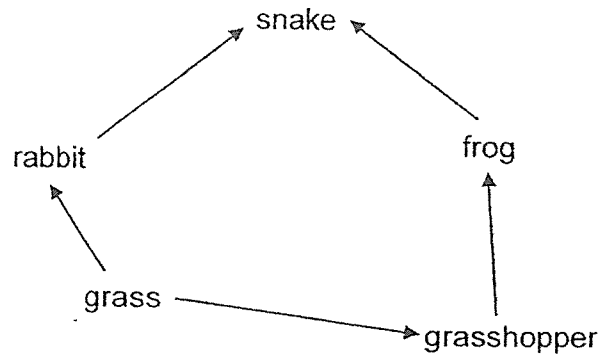

Organisms Y and Z represent two consumers in the food web.

The graph shows how the populations of organisms Y and Z change over a period of five years.

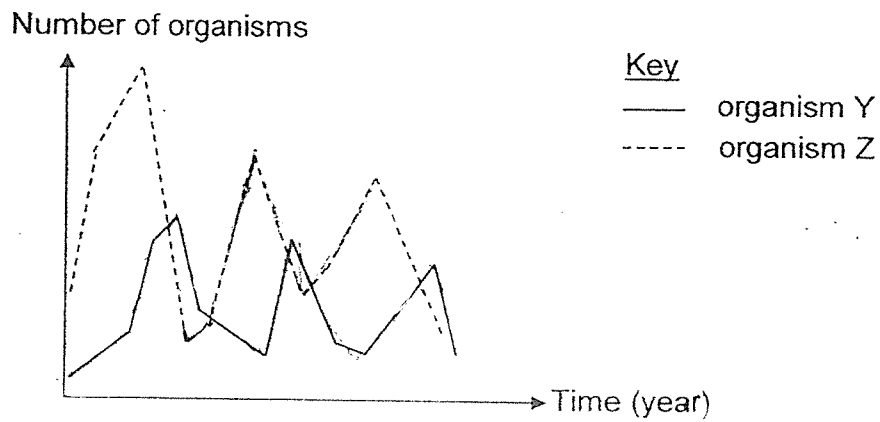

Based on the information, which pair of organisms is most likely to be organisms Y and Z?

	Organism Y	Organism Z
(1)	grasshopper	grass
(2)	frog	rabbit
(3)	rabbit	snake
(4)	snake	frog

15. The table shows the properties of two objects, X and Y.

Property	X	Y
It is flexible.		✓
It is waterproof.	✓	✓
It breaks easily.	✓	
It does not allow light to pass through.	✓	✓

Key

✓ : present

Which of the following best identifies objects X and Y?

	X	Y
(1)	metal ruler	rubber band
(2)	newspaper	plastic scissors
(3)	wooden pencil	plastic ruler
(4)	ceramic spoon	rubber boots

16. The water cycle on Earth can take place continuously because water _____.

- A melts at 0 °C and boils at 100 °C
- B can change from one state to another
- C has volume and cannot be compressed
- D is important for the survival of living things

- (1) B only
- (2) D only
- (3) A, B and C only
- (4) A, B, C and D

17 Study the diagram.

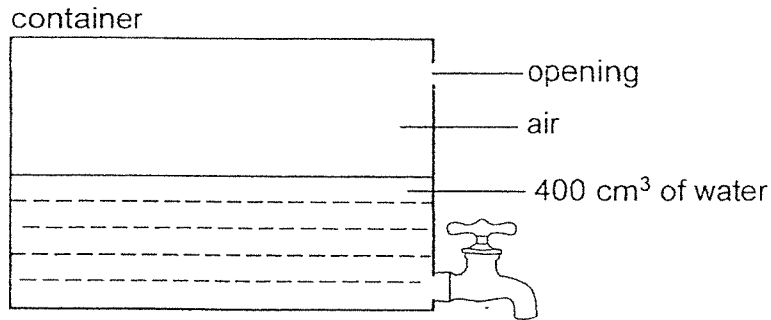

The volume of the container is 800 cm^3 and it contains 400 cm^3 of water. When the tap is turned on, 100 cm^3 of water flows out before the tap is turned off.

Which graph shows the changes in the volume of water and air in the container?

Key

———— water

----- air

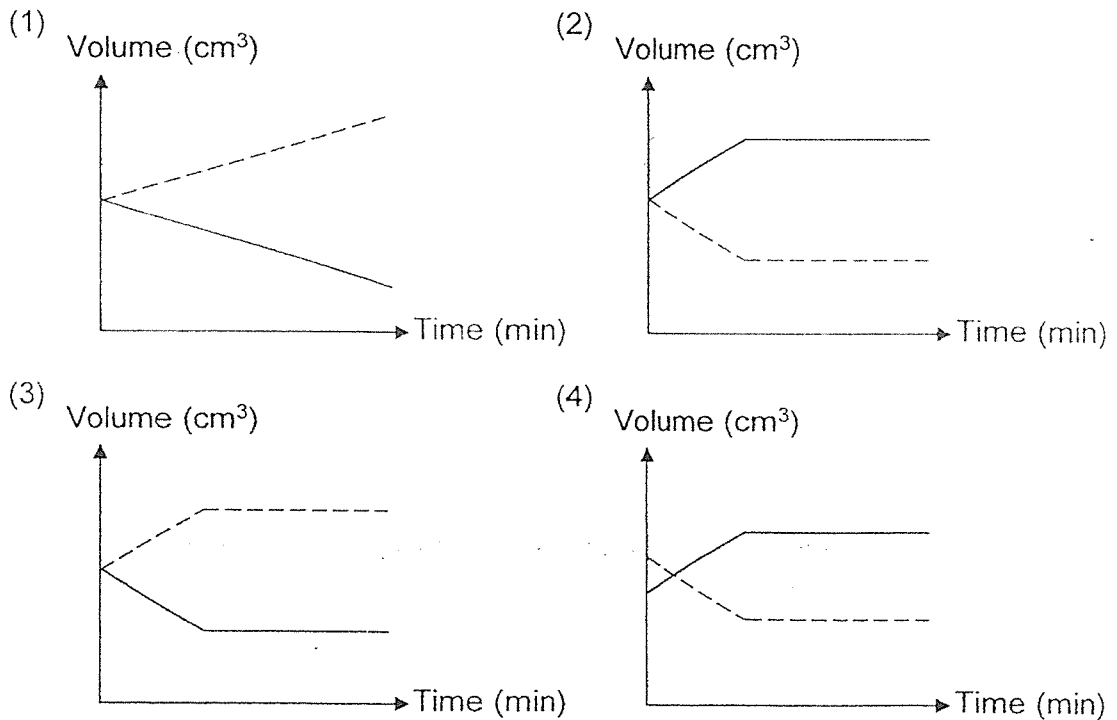

- 18 The table shows the boiling point and freezing point of four substances.

Substance	Freezing point (°C)	Boiling point (°C)
P	2	55
Q	10	60
R	15	75
S	30	95

Which statements are correct?

- A Substance P is in the solid state at 1 °C.
- B All the substances are in the liquid state at 40 °C.
- C Substances R and S are in the liquid state at 90 °C.
- D Substances Q and R are in the gaseous state at 70 °C.

- (1) A and B only
- (2) C and D only
- (3) A, B and C only
- (4) B, C and D only

19 Study the set-ups.

Similar beakers and glass dishes were used for all the set-ups. Set-ups F and H used equal amounts of ice and the containers in set-ups F and G were wider.

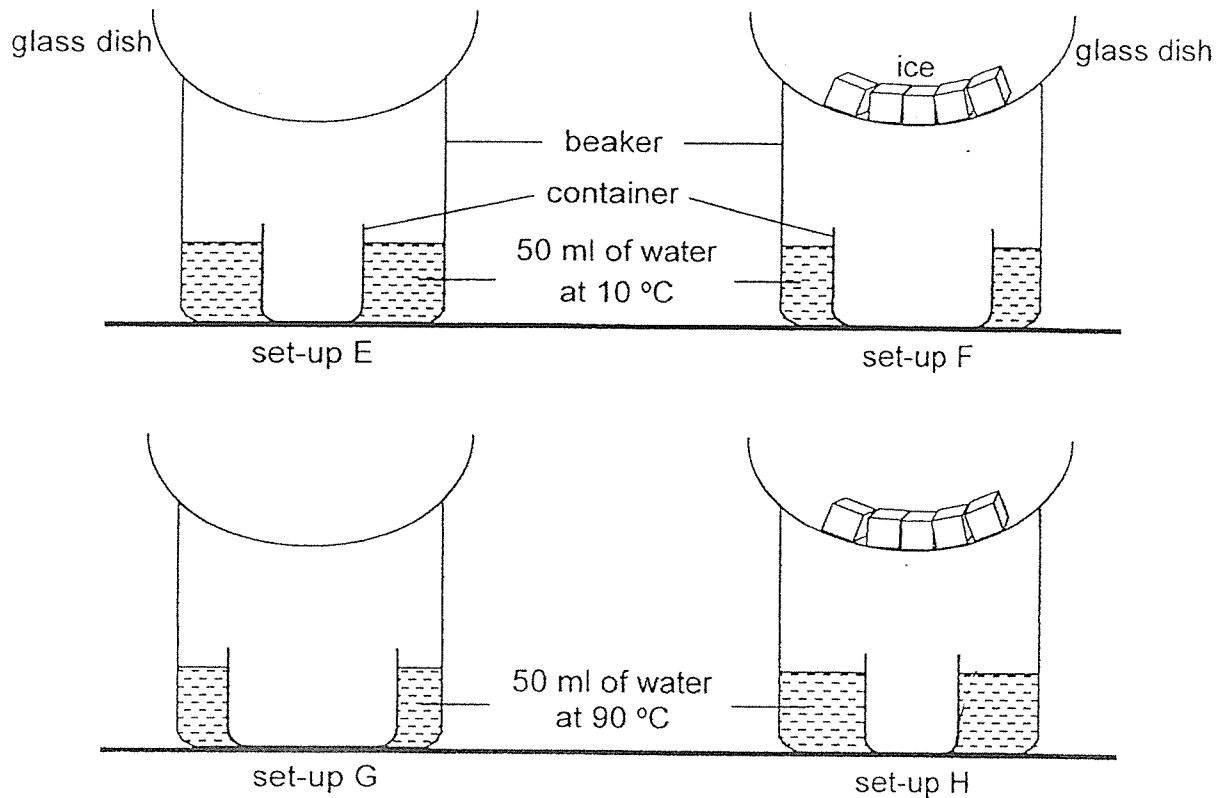

In which set-up would the container collect the least amount of water after ten minutes?

- (1) set-up E
- (2) set-up F
- (3) set-up G
- (4) set-up H

- 20 Joshua set up a game as shown. The buzzer sounds when the ring touches the metal structure. The player wins when the ring is moved from S to T without sounding the buzzer.

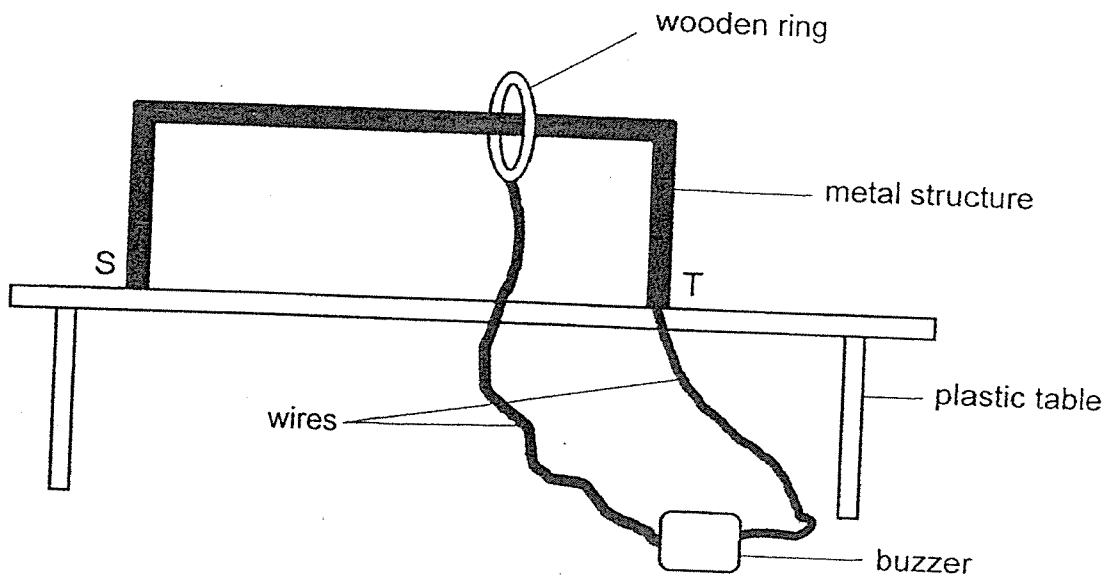

During a game, the buzzer did not sound when the ring touched the metal structure.

What improvement(s) must Joshua make to his set-up to ensure the buzzer sounds?

- A Use a metal ring
 - B Use a shorter wire
 - C Use a smaller ring
 - D Add a battery to the set-up
- (1) A only
- (2) A and D only
- (3) B and C only
- (4) C and D only

- 21 Nathalie was given three rods, P, Q and R, made of different materials. She placed them in various positions, A, B and C, in the circuit shown.

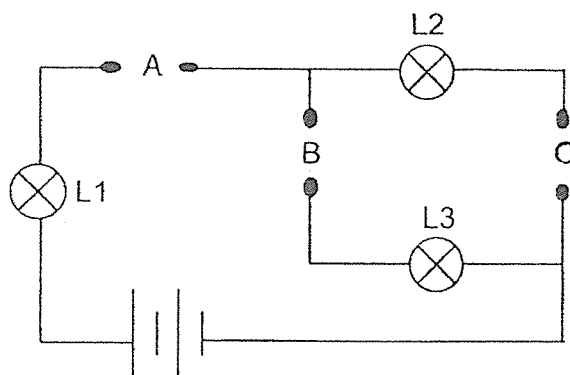

The results of the experiment were shown in the table. A tick (✓) was placed in the box when any of the lamps, L1, L2 or L3, lit up during the experiment.

Positions where rods were placed			Did the lamp light up?		
A	B	C	L1	L2	L3
P	Q	R	✓	✓	
Q	R	P			
R	P	Q	✓		✓

Which conclusion is correct?

- (1) Only rod R is an electrical conductor.
- (2) Only rods P and Q are electrical conductors.
- (3) Only rods P and R are electrical conductors.
- (4) Rod P is the best electrical conductor, followed by rod R and lastly rod Q.

- 22 Lily conducted an experiment by heating three rods of identical length made of different metals, X, Y and Z, for 20 minutes. She recorded the length of each rod before and after heating.

Metal	Length before heating (mm)	Length after heating (mm)
X	200	203
Y	200	212
Z	200	208

Lily noticed that there were gaps between the train tracks as shown. She also observed that the gap was smaller on a hot day.

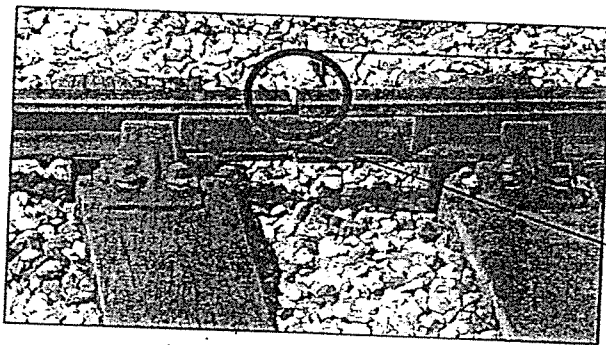

gap between the train tracks

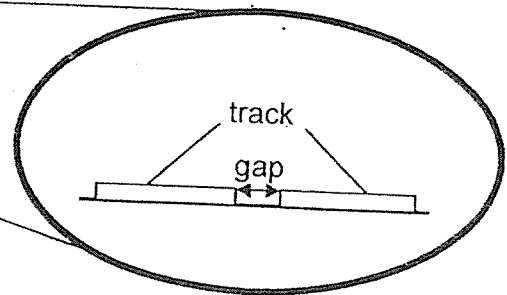

magnified view of the gap

If metals X, Y and Z were used to make the train tracks, which metals would result in the smallest and largest gaps between the tracks on a hot day?

	Smallest gap	Largest gap
(1)	Y	Z
(2)	Z	Y
(3)	X	Z
(4)	Y	X

- 23 The set-up shows light shining on three sheets, A, B and C, made of different materials in a dark room. Only one sheet allowed most light to pass through. Each sheet had a hole of the same height cut out in different shapes.

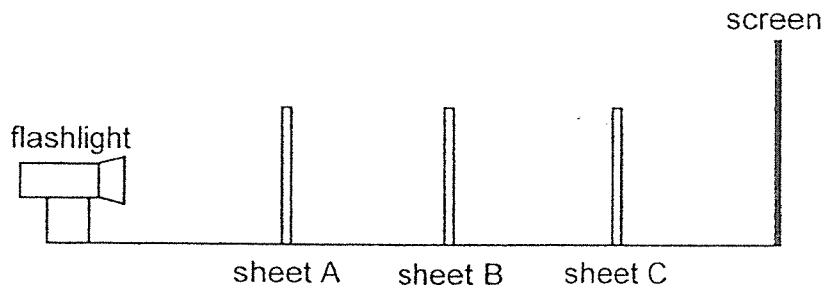

The diagram shows the shadow seen on the screen.

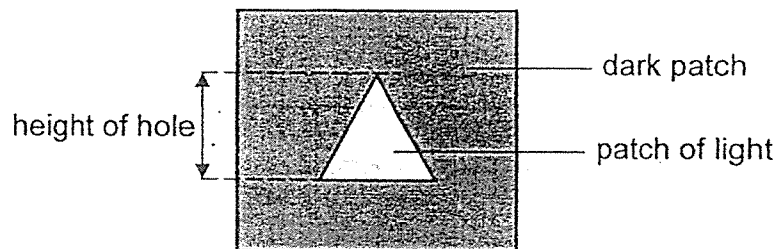

Which of the following represent sheets A, B and C?

Key

does not allow light to pass through

allows most light to pass through

	Sheet A	Sheet B	Sheet C
(1)			
(2)			
(3)			
(4)			

- 24 Rahman pushed a toy which was attached to a spring downwards as shown in diagram 1. When he removed his hand, part Y of the toy jumped up as shown in diagram 2.

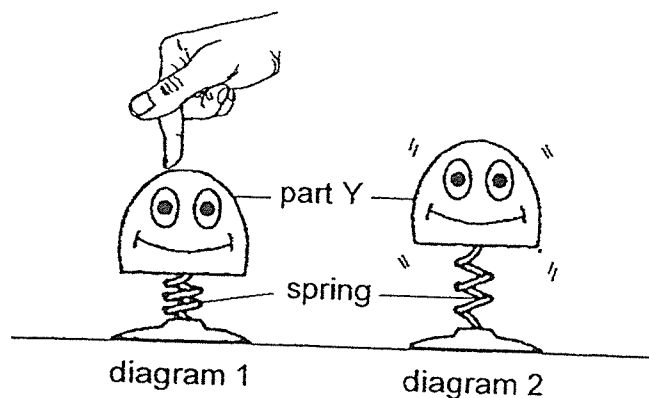

Which of the following shows the correct energy conversion?

	Toy pushed down	Compressed spring	Y jumped up
(1)	heat energy	→ potential energy	→ kinetic energy
(2)	heat energy	→ kinetic energy	→ kinetic + heat energy
(3)	kinetic energy	→ kinetic energy	→ potential energy
(4)	kinetic energy	→ potential energy	→ kinetic + potential energy

- 25 A solar-powered toy flower was used to carry out an experiment. The procedure is described as shown in the table.

solar-powered toy flower

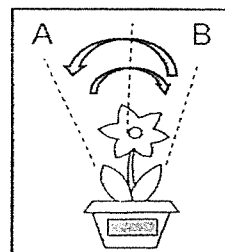
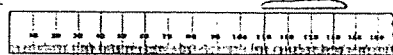
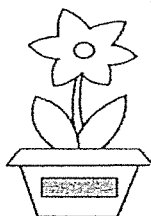

movement of toy flower

Procedure	
1	Place a lit lamp 5 cm away from the toy flower.
2	Record the number of rounds the toy flower makes in 5 minutes.
3	Repeat steps 1 and 2 by placing the lamp at 10 cm and 15 cm mark of the ruler.

Which statements are possible aims and conclusions for the experiment?

	Aim	Conclusion
A	To find out how light intensity affects the amount of electrical energy produced.	When there is more electrical energy, the light intensity increases.
B	To find out how light intensity affects the speed at which the toy flower moved.	The greater the light intensity, the faster the toy flower moves.
C	To find out how light intensity affects the amount of electrical energy produced.	The greater the light intensity, the greater the amount of electrical energy produced.
D	To find out how light intensity affects the speed at which the toy flower moved.	Light intensity has no effect on the amount of electrical energy produced.

- (1) A and D only
- (2) B and C only
- (3) B, C and D only
- (4) A, B, C and D

- 26 Two identical pieces of paper, one crumpled into a ball, are released from the same height at the same time as shown.

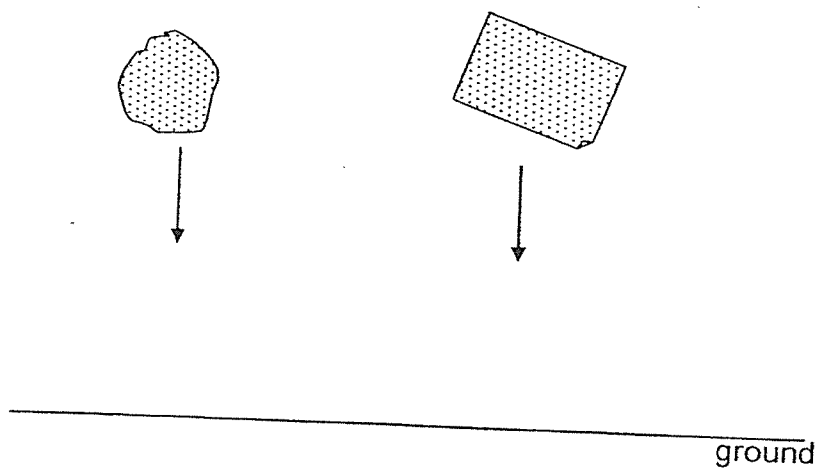

The crumpled paper is observed to reach the ground first.

Which explanation is correct?

- (1) It has a greater mass.
- (2) Its weight pulls it down faster.
- (3) It has less gravitational force acting on it.
- (4) There is less friction between the paper and the air.

- 27 The diagrams show four different springs, P, Q, R and S, with different loads hung on them. All the four springs have the same original length.

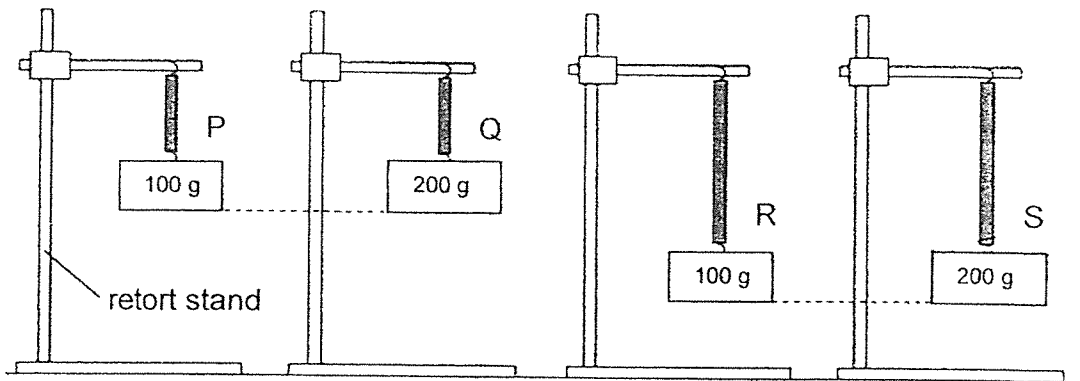

Based on the diagram above, which statements are correct?

- A Spring R is less stiff than spring P.
- B Spring Q stretches more easily than spring P.
- C Spring Q exerts less elastic spring force than spring S.
- D Spring S exerts a greater elastic spring force than spring R.

- (1) A and D only
- (2) B and C only
- (3) B and D only
- (4) A, C and D only

28 Anne suspended a copper bar, an iron bar and two bar magnets from a horizontal rod.

Which observation is possible?

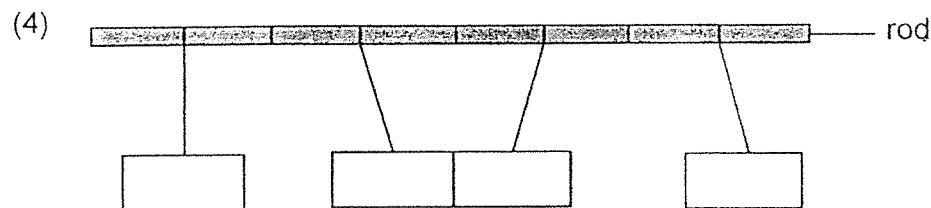
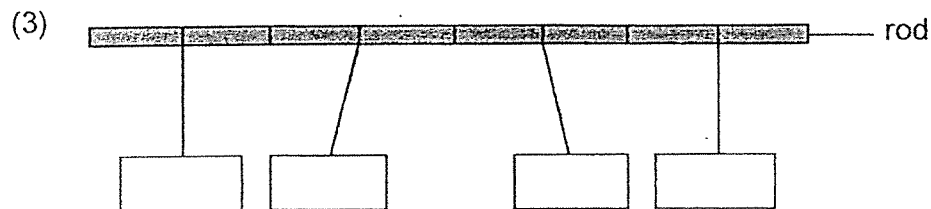
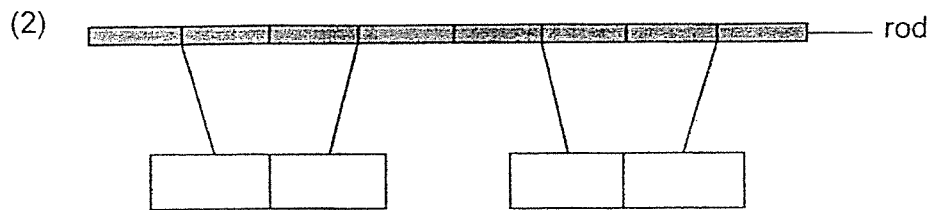
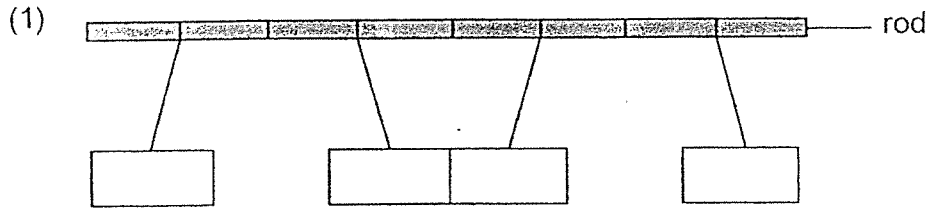

End of Booklet A

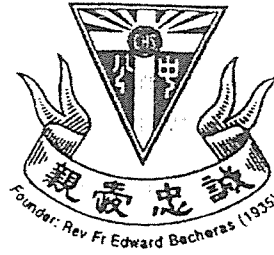

CATHOLIC HIGH SCHOOL
PRELIMINARY EXAMINATION (2023)

PRIMARY SIX

SCIENCE

BOOKLET B

Name: _____ ()

Class: Primary 6 - _____

Date: 24 August 2023

Parent's Signature: _____

12 questions

44 marks

Total Time for Booklets A and B: 1 hour 45 minutes

Booklet A	56
Booklet B	44
Total	100

INSTRUCTIONS TO CANDIDATES

Do not turn over this page until you are told to do so.

Follow all instructions carefully.

Answer all questions.

Write your answers in this booklet.

This booklet consists of 20 printed pages, excluding the cover page.

Booklet B (44 marks)

For questions 29 to 40, write your answers in this booklet.

The number of marks available is shown in brackets [] at the end of each question or part question. (44 marks)

- 29 The diagrams below show blood entering and leaving the brain and the small intestine through blood vessels W, X, Y and Z.

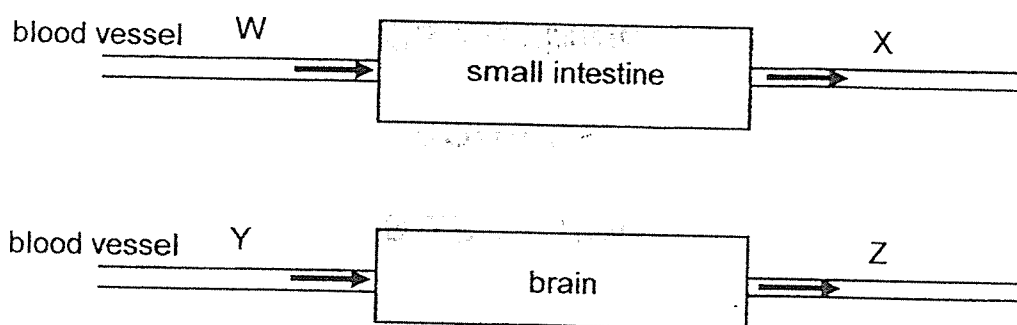

- (a) Fill in the blanks below with W, X, Y or Z. [1]

(i) carries blood rich in oxygen: _____

(ii) carries blood rich in digested food: _____

- (b) A patient has a lung condition where his lungs are filled with fluid (liquid). He is observed to have a higher heart rate than normal. Explain why. [2]

(Go on to the next page)

SCORE	3
-------	---

Continue from Question 29

Fish A and organism B live in the same environment. Organism B lives on fish A by attaching onto its gills without damaging them. It feeds on the blood in the gills.

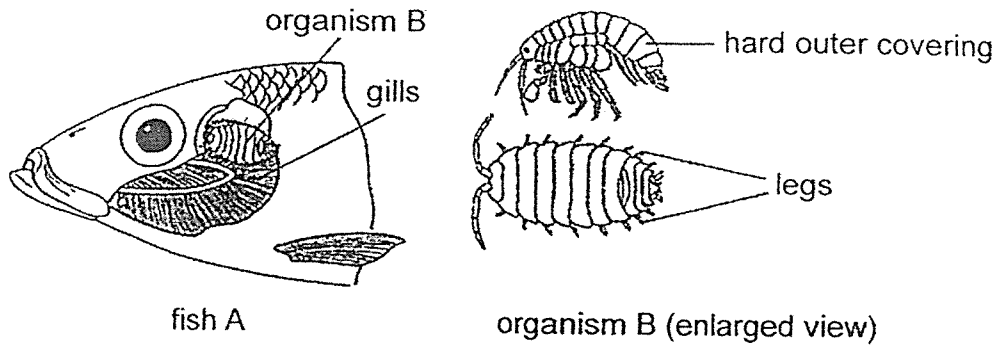

- (c) Based on the information provided, explain how organism B affects gaseous exchange in the fish. [1]

(Go on to the next page)

SCORE	1
-------	---

30 The diagram shows how food and water are transported by the stem to and from the different parts of a plant, F, G and H.

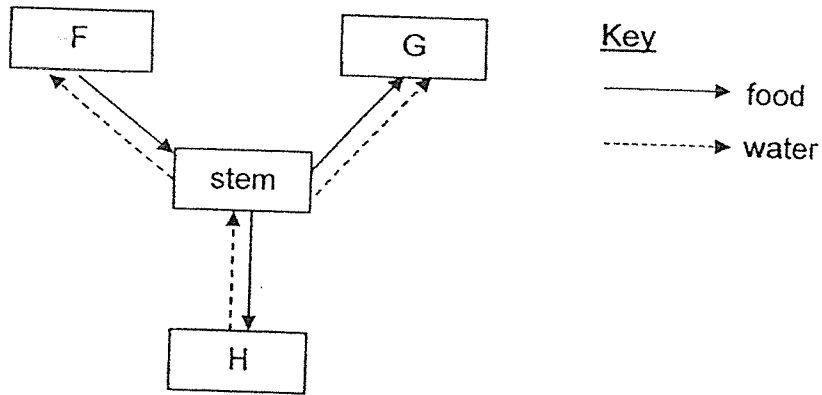

(a) Identify parts F and H.

[1]

F: _____

H: _____

Jane removed a small section of a celery stalk at position X. The stalk was then placed into a measuring cylinder filled with blue-coloured water.

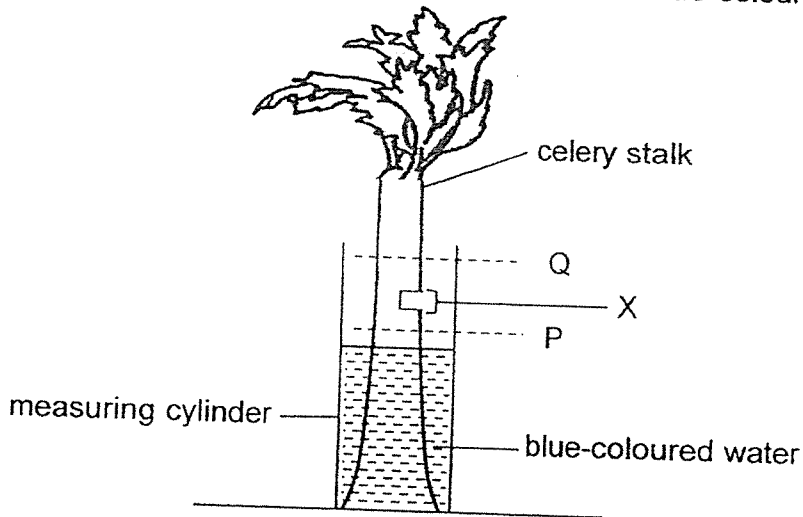

After two hours, the stalk was removed from the measuring cylinder. Jane cut two sections across the stalk at positions P and Q. She labelled the two cut sections T and U.

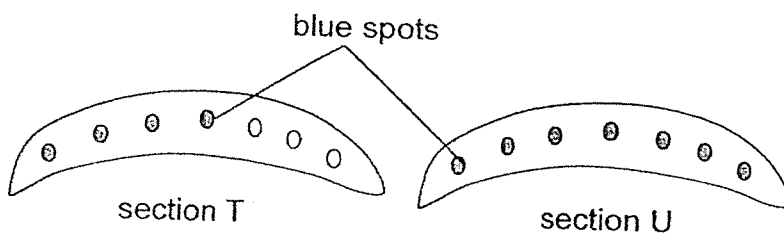

(Go on to the next page)

SCORE	1
-------	---

Continue from Question 30

- (b) Which section, T or U, was taken from position Q? Explain your answer.

[1]

Jane performed another experiment to find out how the number of leaves affects the volume of water transported.

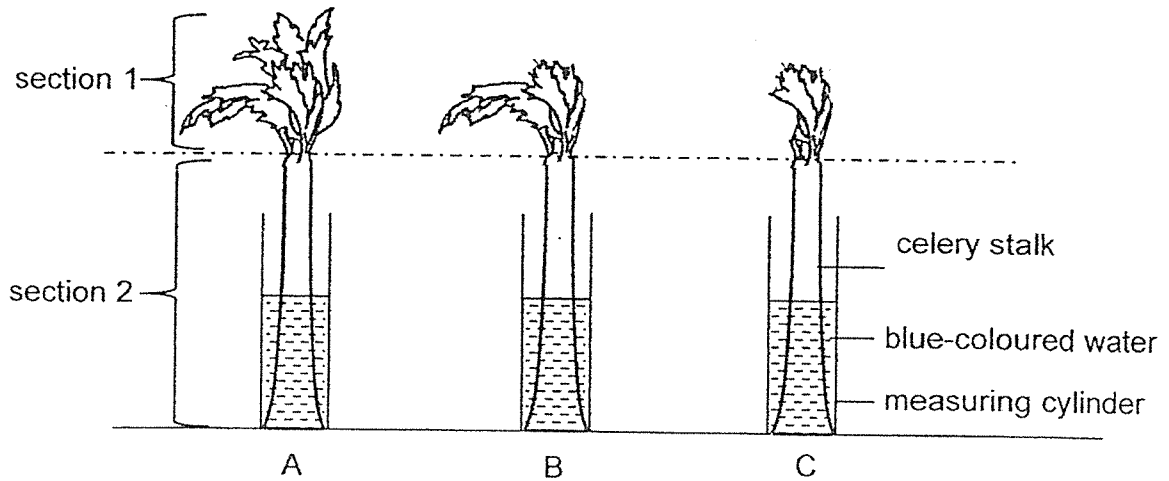

One method of obtaining the results is to compare the volume of water in the measuring cylinder before and after the experiment.

After some time, Jane observed that none of the leaves in A, B and C were stained blue at section 1. She removed all the stalks and cut section 2 of each stalk into 15 parts of equal thickness.

- (c) Using the cut parts in section 2 only, suggest how Jane can conclude which stalk transported the most water.

[1]

(Go on to the next page)

SCORE	2
-------	---

- 31 Sheela discovered a deserted island with only three types of plants. Their locations on the island were noted as shown in diagram 1.

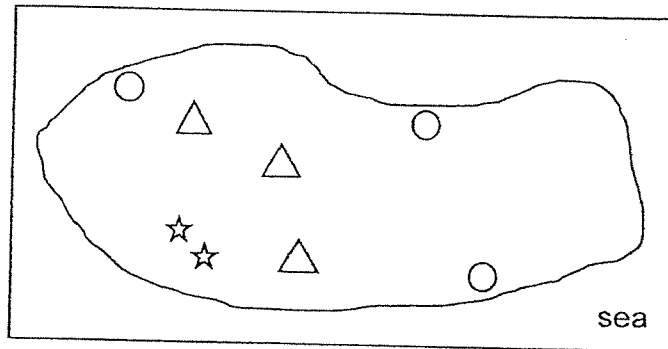

diagram 1

She returned to the island a year later and noted the locations of the three types of plants as shown in diagram 2.

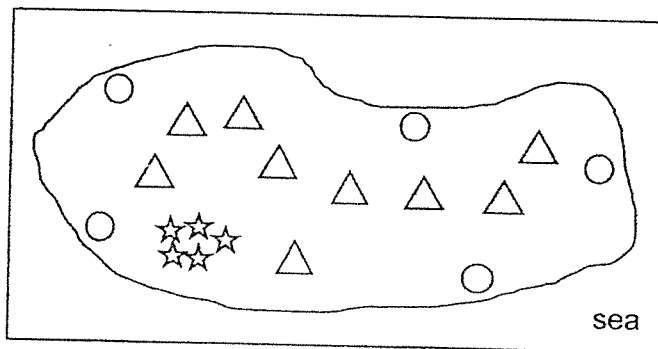

diagram 2

Key

- ☆ : plant E
- △ : plant F
- : plant G

- (a) Identify the method of dispersal for each type of plant.

[1]

Plant	Method of dispersal
E	
F	
G	

- (b) State a characteristic of the fruit/seed of plant F that helps in its dispersal stated in (a).

[1]

(Go on to the next page)

SCORE	2
-------	---

Continue from Question 31

When she returned to the same island a few years later, she discovered tall buildings built on it. Again, she noted the locations of the three types of plants as shown in diagram 3.

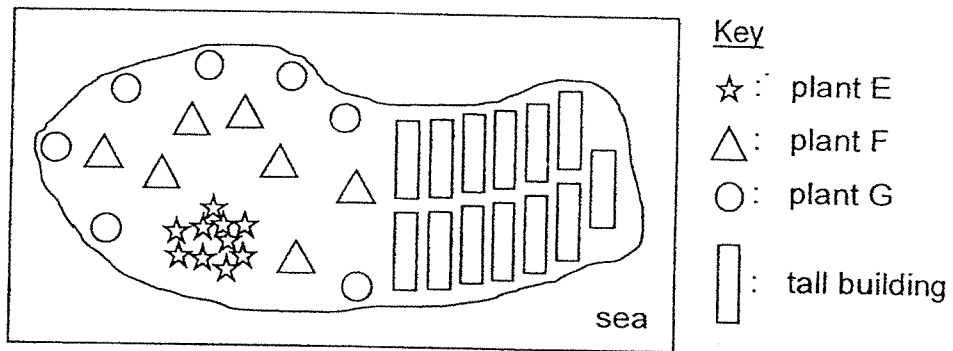

diagram 3

Sheela observed that plant F did not reproduce well after the tall buildings were built.

(c) Based on your answer in (a), explain why.

[1]

(Go on to the next page)

SCORE	1
-------	---

32 The set-up as shown was used to find out how different colours of light affect the rate of photosynthesis.

Four identical set-ups were placed in a dark room and each plant had a different coloured light shone on it. The distance moved by the air bubble in each set-up was measured after a fixed time.

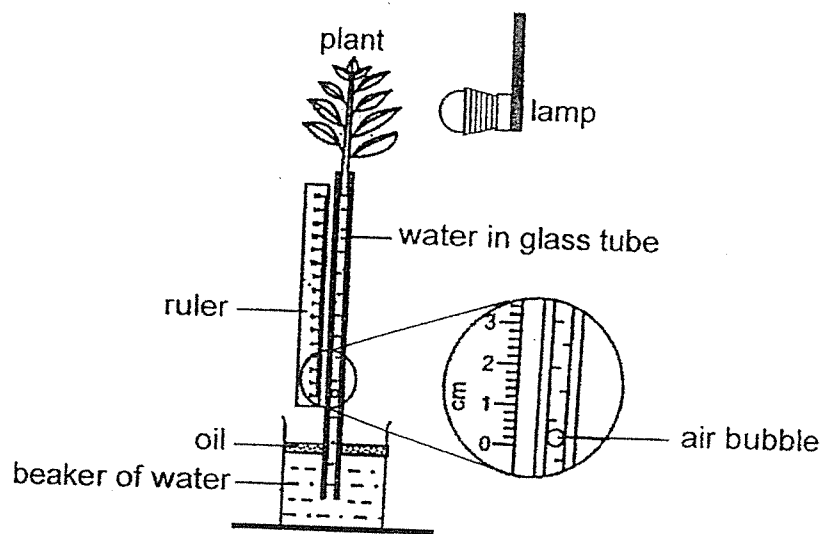

The results are as shown.

Colour of light	Distance moved by the air bubble (cm)
blue	16
white	5
green	10
orange	11

(a) Other than the size of the glass tube, state two variables that should be kept constant for the investigation.

[1]

(i) _____

(ii) _____

(Go on to the next page)

SCORE	1
-------	---

Continue from Question 32

- (b) Based on the results, which coloured light resulted in the highest rate of photosynthesis? Explain why. [2]

- (c) State why the distance moved by the air bubble was 2 cm when no light was shining on the plant. [1]

(Go on to the next page)

SCORE	3
-------	---

- 33 Organism L is commonly observed to be growing on tree trunks. It is made up of two organisms, A and F, living together.

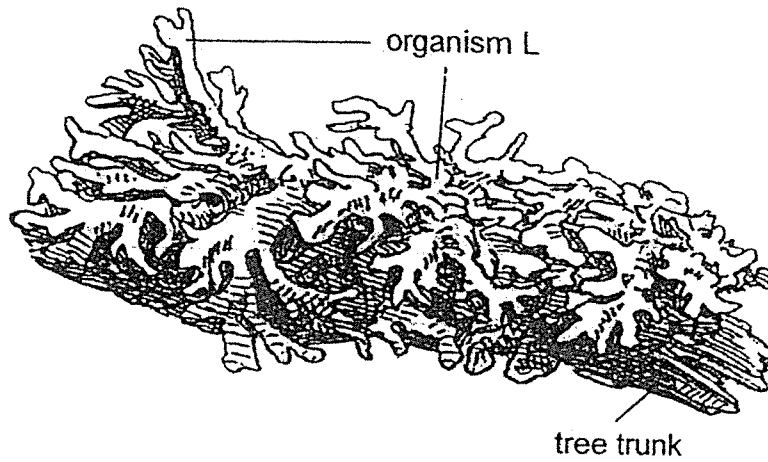

The table shows the characteristics of organism A and organism F.

Organism A	Organism F
contains a green pigment	does not contain a green pigment
produces oxygen in the presence of light	is unable to make food
roots cannot absorb water well	traps water easily

From the information given, how do organism A and organism F benefit by living together?

[2]

(a) Benefit for organism A

Benefit for organism F

(Go on to the next page)

SCORE	2
-------	---

Continue from Question 33

Organism L grows well in an environment with little air pollution.

Wayne carried out an investigation to find out more about the air quality in his neighbourhood. He prepared three identical sticky cardboards and placed them at three different locations in his neighbourhood.

24 hours later, he retrieved the three cardboards and observed different amounts of particles (pollutants) collected on each cardboard as shown.

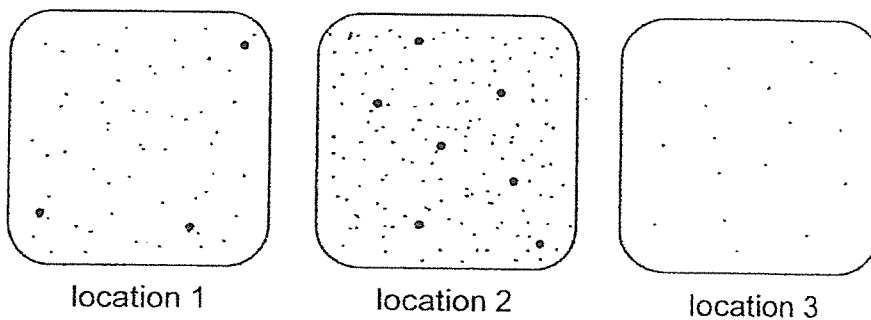

- (b) Based on the information given, in which location, 1, 2 or 3, will organism L grow the best? Explain your answer. [1]

- (c) Suggest one way to improve the reliability of Wayne's results.

- (d) State one example of Man's activity that could have led to the results obtained for location 2. [1]

(Go on to the next page)

SCORE	/
	3

34 Study the information about organisms W, X, Y and Z.

W	X	Y	Z
producer	prey only	predator only	prey and predator

(a) Draw a food web to show the food relationships among organisms W, X, Y and Z.

[1]

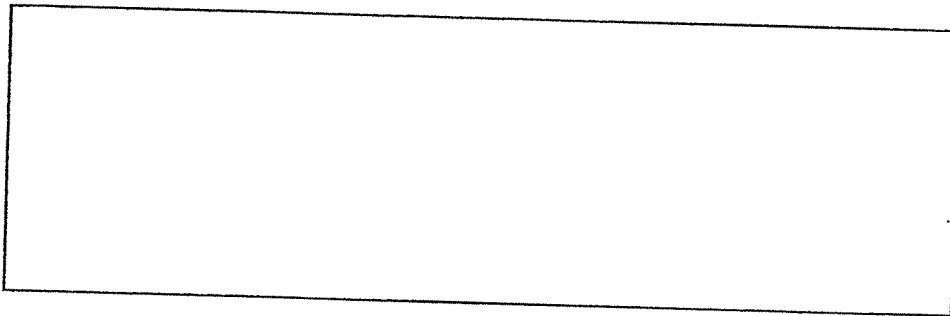

(b) Explain how decomposers benefit organism W.

[1]

The diagram shows organism Q. Its body resembles the leaves of plant P.

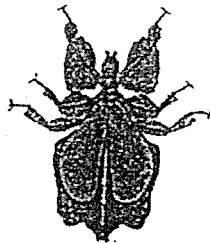

organism Q

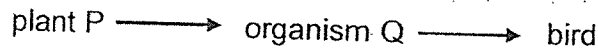

(c) Other than having fewer plant P to feed on, suggest another reason why the population of organism Q decreases when there is a drastic decrease in the population of plant P.

[1]

(Go on to the next page)

SCORE	3
-------	---

35 Jia Xuan wanted to study which material of block absorbs water the fastest.

She put three blocks made of different materials into 1000 cm³ of water. Each block was removed and the volume of water left in each container was measured at the 1st hour and 12th hour.

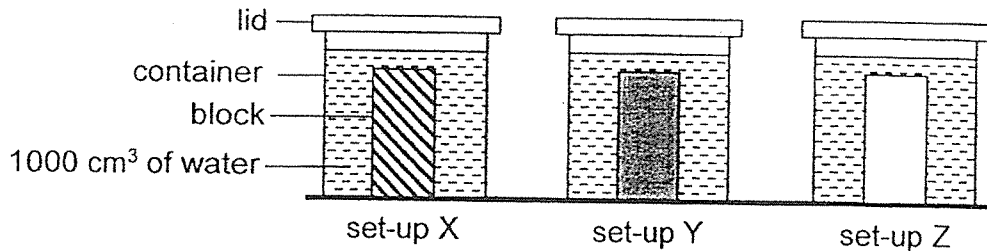

The results are as shown.

Set-up	Volume of water in the container (cm ³)		
	At the start	At 1 st hour	At 12 th hour
X	1000	966	900
Y	1000	965	815
Z	1000	962	750

(a) (i) State what Jia Xuan can conclude from the study. [1]

(ii) Explain your answer in (a)(i). [2]

(b) Jia Xuan wanted to build a wall to divide her room space. Suggest another property that she could study to find out which block is most suitable for building the wall. [1]

(Go on to the next page)

SCORE	4
-------	---

36 The diagram shows three batteries and a light bulb.

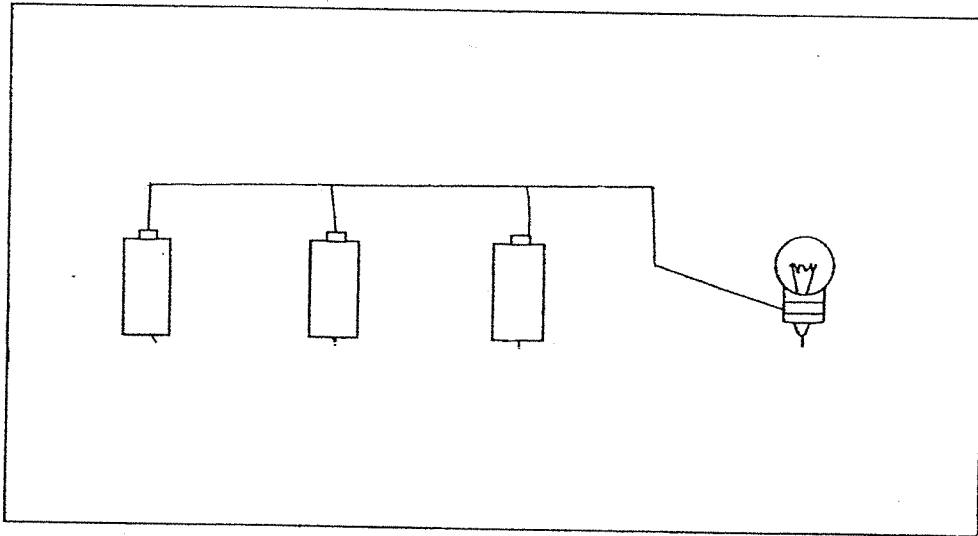

(a) In the diagram above, complete the circuit so that the bulb will be the brightest.

[1]

The diagram shows how bulbs, P, Q, R, S and T, are arranged in a house consisting of four rooms - the living room, the kitchen and two bedrooms.

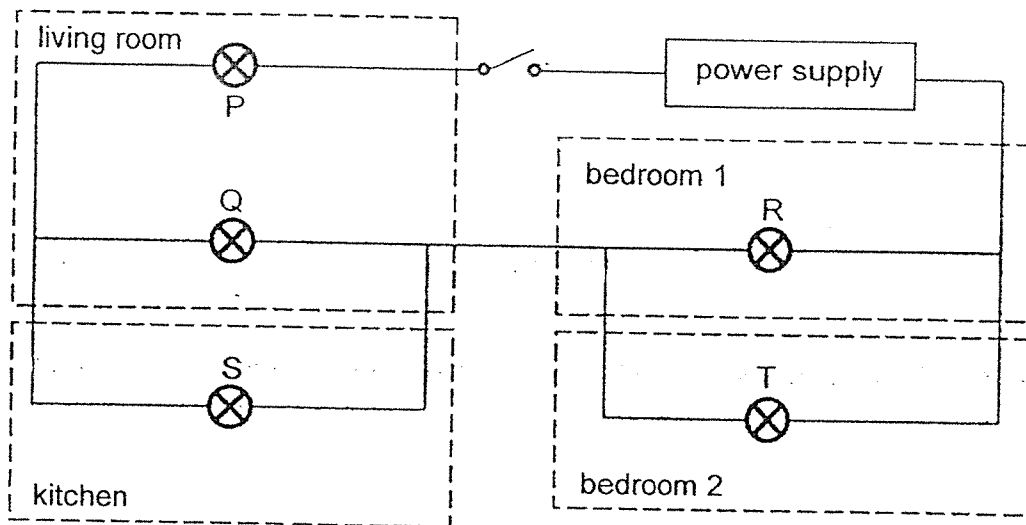

(Go on to the next page)

SCORE	1
-------	---

Continue from Question 36

- (b) State two disadvantages of using the circuit shown in the diagram on page 13.

[2]

Disadvantage 1

Disadvantage 2

One switch is added to the kitchen and another to the bedroom 1 so that the bulb in each room can be switched on and off independently.

- (c) Indicate the positions of these two switches by marking each one with a cross (X) in the diagram on page 13.

(Go on to the next page)

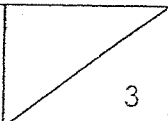
SCORE	
-------	---

37 Some birds huddle when the surrounding temperature drops to $-80\text{ }^{\circ}\text{C}$.

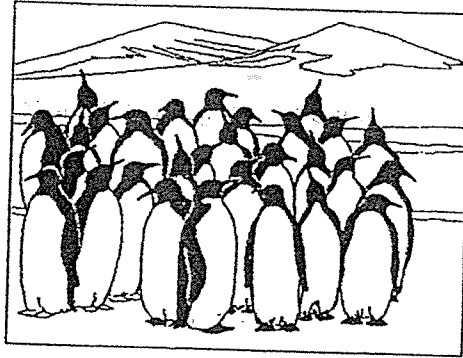

Guo Bin wants to find out if huddling helps to keep the birds warm. He has a bundle of test tubes held together with a rubber band and a single test tube. All test tubes contain equal amounts of hot water at $60\text{ }^{\circ}\text{C}$. The investigation is carried out in a classroom.

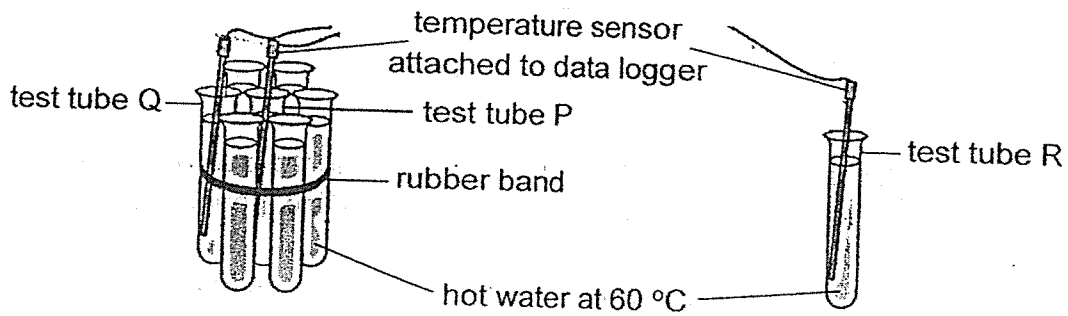

The temperature inside test tubes P, Q and R is recorded every minute for ten minutes using a data logger. His results are as shown.

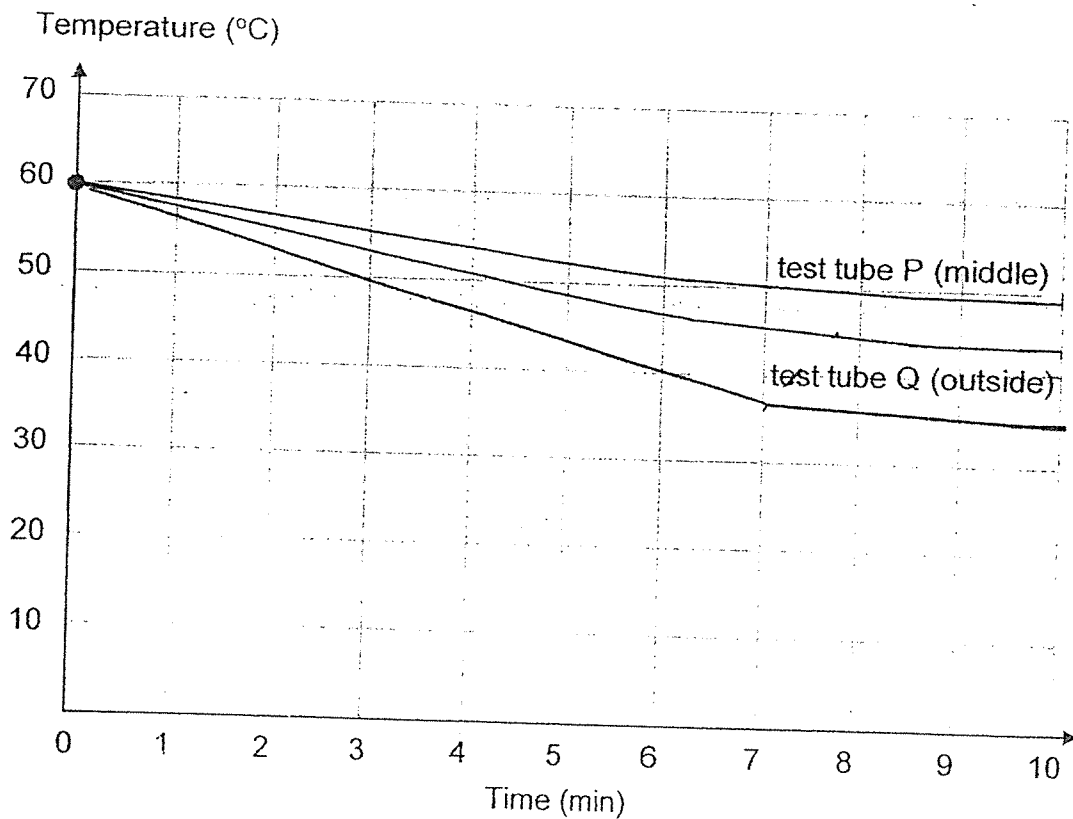

Continue from Question 37

Guo Bin makes a statement, "My results suggest that huddling keeps the middle bird warmer."

- (a) Based on the graph, state the evidence that supports his statement. [1]

- (b) On the graph, draw a line and label it to predict the result for test tube R. [1]

- (c) Birds on the outside of the huddle take turns to move to the inner parts of the huddle. Suggest how this behaviour helps these birds to survive in the cold. [1]

(Go on to the next page)

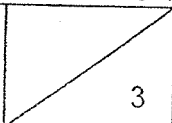
SCORE	
-------	---

38 Rita visited a country during winter. She got up a bus parked at an open air carpark.

When the heater in the bus was turned on, she observed that the inner surface of the bus window soon turned foggy.

(a) Explain how fog was formed on the inner surface of the window. [2]

Rita drew a star on the 'foggy' window with her finger.

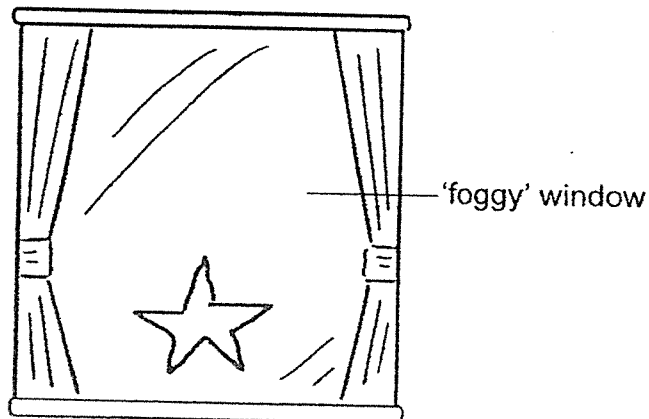

(b) An hour later, the star disappeared even though no one wiped it away. Explain why. [1]

(Go on to the next page)

SCORE	3
-------	---

- 39 The diagram shows a toy. When the elastic band is pulled and then released, the wheel will spin before flying off.

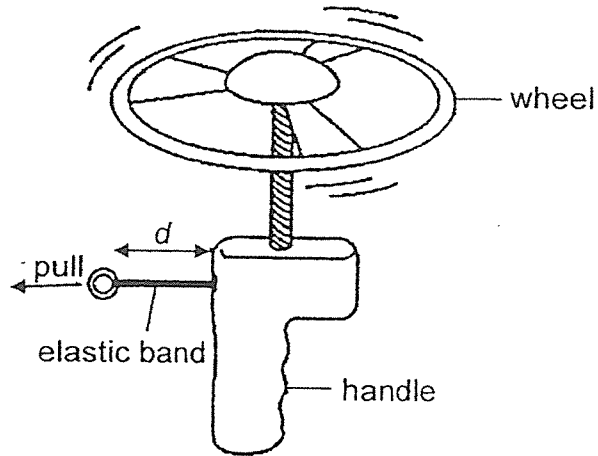

Razif wants to find out how the number of spins of the wheel changes when the elastic band is pulled to different lengths, d . The results are as shown.

Length of elastic band when pulled, d (cm)	8	16	24
Number of times the wheel spins	4	7	10

- (a) Explain, in terms of energy changes, how the length of elastic band when pulled, d , affects the number of times the wheel spins. [2]

- (b) Suggest how using the same wheel helps to make the investigation a fair test. [1]

(Go on to the next page)

SCORE	3
-------	---

- 40 Edison designed a set-up to help feed his pet hamster when he went on a holiday.

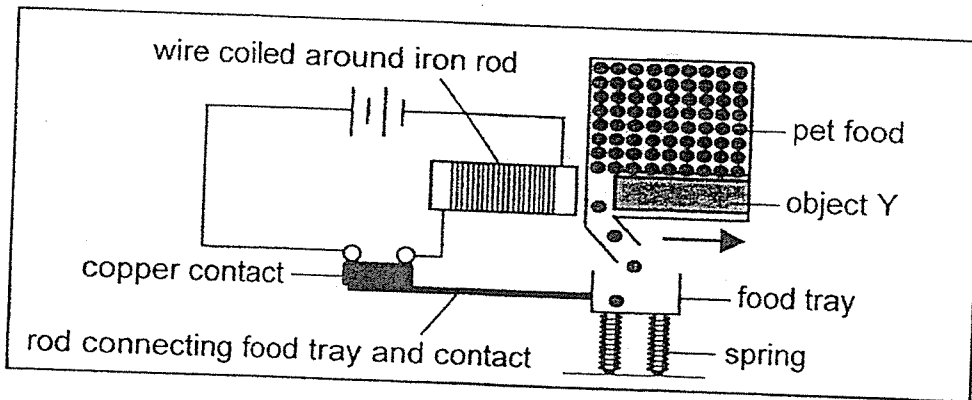

diagram 1

In diagram 1, object Y moves to the right to allow the pet food to dispense when the food tray is empty.

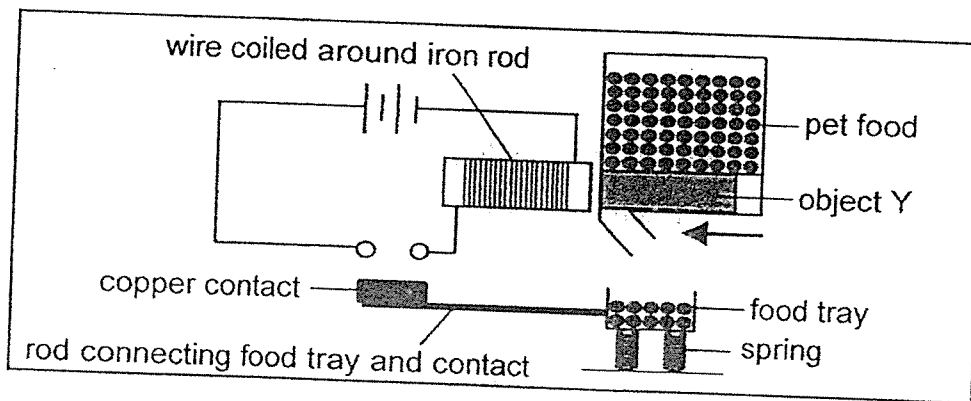

diagram 2

In diagram 2, object Y moves to the left to stop the pet food from dropping when the food tray is fully filled.

- (a) Identify object Y.

[1]

- (b) Explain how the set-up in diagram 2 stops dropping food into the food tray when it is fully filled.

[2]

(Go on to the next page)

SCORE	3
-------	---

Continue from Question 40

- (c) Edison wanted more pet food to be dispensed into the food tray.

By changing either the food tray or the springs, suggest one modification to his set-up. Explain, in terms of forces, how it works. [2]

Modification

Explanation

End of Booklet B

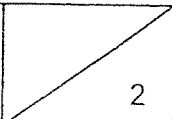
SCORE	
-------	---

YEAR : 2023
 LEVEL : PRIMARY 6
 SCHOOL : CATHOLIC HIGH SCHOOL
 SUBJECT : SCIENCE
 TERM : PRELIM

(BOOKLET A)

Q1	3	Q2	3	Q3	4	Q4	2	Q5	4
Q6	4	Q7	1	Q8	2	Q9	2	Q10	1
Q11	2	Q12	3	Q13	1	Q14	4	Q15	4
Q16	1	Q17	3	Q18	1	Q19	1	Q20	2
Q21	3	Q22	4	Q23	1	Q24	4	Q25	2
Q26	4	Q27	1	Q28	4				

(BOOKLET B)

Q29	a)	i) W, Y ii) X, Y								
	b)	When the lungs are filled with fluid, less gaseous exchange takes place. The heart rate increases to pump blood faster to transport more oxygen to other parts of the body.								
	c)	Less blood reaches the gills for less gaseous exchange.								
Q30	a)	F: leaf R: root								
	b)	(C) Section T (E) Some of the water-carrying tubes on T were stained blue. (R) Water could not travel up the water-carrying tubes which were removed at Position X.								
	c)	Count the number of celery parts with the most blue spots for each stalk.								
Q31	a)	<table border="1"> <thead> <tr> <th>Plant</th> <th>Method of dispersal</th> </tr> </thead> <tbody> <tr> <td>E</td> <td>splitting / explosive action</td> </tr> <tr> <td>F</td> <td>wind / animals</td> </tr> <tr> <td>G</td> <td>water</td> </tr> </tbody> </table>	Plant	Method of dispersal	E	splitting / explosive action	F	wind / animals	G	water
	Plant	Method of dispersal								
	E	splitting / explosive action								
F	wind / animals									
G	water									
b)	<p>If wind dispersal in (a) wing-like structure / small and light</p> <p>If animal dispersal in (a) fleshy / juicy / sweet-smelling fruit / hook-like structure / stiff hairs</p>									
c)	<p>If wind dispersal in (a) The tall buildings blocked the wind hence fewer seeds were dispersed further away from the parent plants. This increased overcrowding which led to increased competition for space, water, nutrients and light.</p> <p>If animal dispersal in (a) When the land was cleared for the construction of tall buildings, the animals lost their habitats so this reduced their access to food and water. Hence there were fewer animals to disperse the fruit / seeds.</p>									

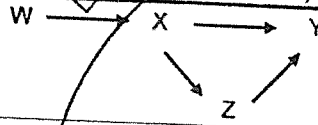
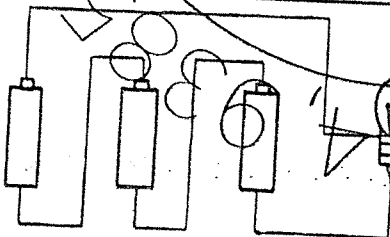
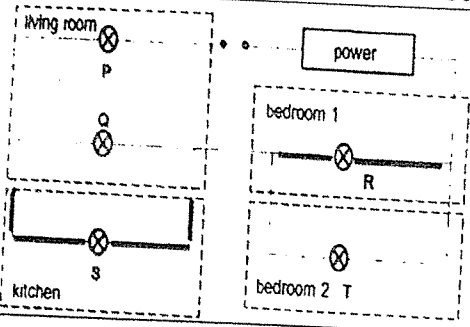
Q32	<p>a) i) distance of the lamp from the plant ii) number of leaves on the plant</p> <p>b) (C) Blue light (E) The distance moved by the air bubble was the greatest. (R) The greatest amount of water was taken up by the plant for photosynthesis.</p> <p>c) Some water was lost through the stomata to the surrounding air as water vapour.</p>
Q33	<p>a) <u>Benefit for Organism A</u> Organism F provides water for organism A to perform photosynthesis. <u>Benefit for Organism F</u> Organism A provides food / oxygen for organism F.</p> <p>b) (C) Location 3 (E) The amount of particles collected on the cardboard is the least. (R) Location C has the best air quality.</p> <p>c) Wayne could place two more cards for each location.</p> <p>d) Burning of fossil fuels by factories.</p>
Q34	<p>a) </p> <p>b) Decomposers break down dead matter into simpler substances which are absorbed by organism W as nutrients.</p> <p>c) There are less leaves for Q to blend in with so they are more easily spotted by predators / birds and eaten.</p>
Q35	<p>a) i) The block in set-up Z absorbs water the fastest. ii) The amount of water left in the container in set-up Z is less than the amount of water left in set-ups X and Y at 1st hour. Hence, the most amount of water was absorbed by the block in set-up Z. At 12th hour, the decrease in the amount of water left is the most for the block in set-up Z.</p> <p>b) strength of block</p>
Q36	<p>a) </p> <p>b) i) When Bulb P fuses, the remaining bulbs in the house will not light up. ii) All the bulbs cannot be controlled independently.</p> <p>c) </p>

Q37	a)	For the same amount of time, the temperature of water in test tube P is higher.
	b)	
	c)	Heat is lost faster from the birds on the outside to the cold surroundings. Heat is transferred among the bird in the huddle hence they will not freeze.
Q38	a)	Warm water vapour in the surrounding air in the bus touched the cool inner surface of the window, lost heat and condensed to form water droplets.
	b)	The water droplets on the 'foggy window' gained heat from the warm surroundings in the bus and evaporated to form water vapour.
Q39	a)	As the length of the elastic band when pulled, d , increases, the elastic potential energy possessed by the elastic band increases. This is converted to increased kinetic energy of the wheel hence the number of times the wheel spins increases
	b)	To ensure that the mass of the wheel is kept the same.
Q40	a)	Magnet
	b)	When the tray is fully filled with food, its mass increases and compresses the springs creating an open circuit when the contact does not touch the wires of the electric circuit. The electromagnet becomes demagnetized and becomes a magnetic material. Object Y attracts the iron rod, moves to left and stops food from falling into the tray.
	c)	<p><u>Modification</u> Use springs which are stiffer.</p> <p><u>Explanation</u> A greater force has to be exerted to compress the springs to the same extent to separate the copper contact from the circuit.</p>

