

For each question from 1 to 28, four options are given. One of them is the correct answer. Make your choice (1, 2, 3 or 4). Shade your answer on the Optical Answer Sheet.

(56 marks)

1. The table shows the cell parts that are present in cells A, B, C and D. A tick (✓) indicates the presence of the cell part.

Cell	Cell part			
	Nucleus	Cell Membrane	Cell Wall	Chloroplasts
A		✓		
B		✓	✓	✓
C		✓		
D		✓		

Which of the following is/are plant cell(s)?

- (1) B only  
 (2) A and B only  
 (3) A and D only  
 (4) C and D only
2. The diagram shows parts P, Q, R, S and T, in the human digestive system.

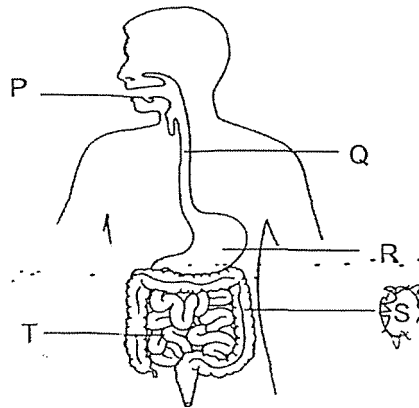

Which of the following statement(s) is/are true about parts P, Q, R, S and T?

- A Digestion is completed at part T.  
 B Only parts R and S produce digestive juices.  
 C Part P breaks down food into smaller pieces.  
 D Part Q transport digested food from the mouth to the stomach.

- (1) B only  
 (2) A and C only  
 (3) B and D only  
 (4) A, C and D only

(Go on to the next page)

3. During a power failure, Mrs Tan was trapped in a lift with eight people for 30 minutes. The ventilation fan stopped working and the lift door could not be opened.

Which of the following shows the likely changes to the amount of the different gases in the lift after 30 minutes?

	Oxygen	Carbon Dioxide	Nitrogen
(1)	Increase	Decrease	Decrease
(2)	Increase	Decrease	No Change
(3)	Decrease	Increase	Increase
(4)	Decrease	Increase	No Change

4. The pictures show two plants, G and H.

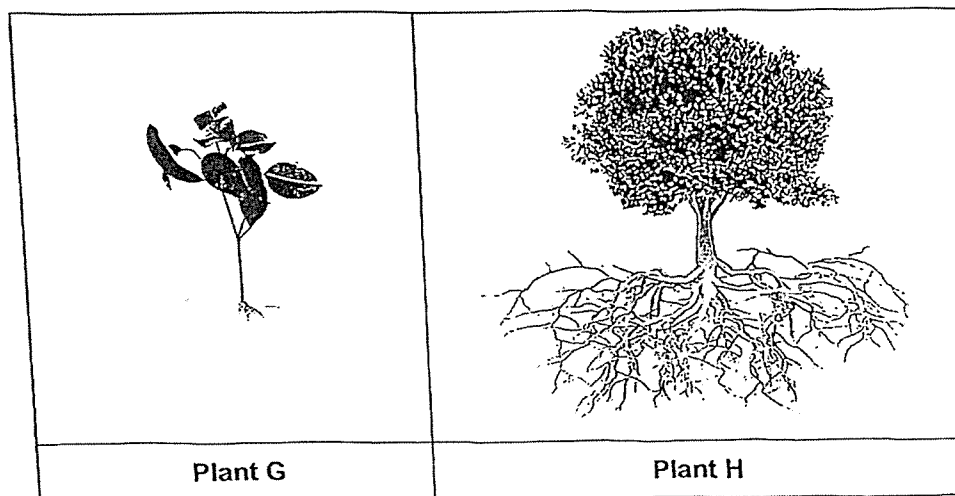

Four students made comments about the plants.

- Aminah: Only the roots of plant H hold the plant firmly to the ground.  
 Bala: Plant G will be uprooted more easily when pulled.  
 Caden: Plant H can make more food than plant G.  
 David: The roots of plant H absorb more water and mineral salts from the soil than the roots of plant G.

Whose comments are true?

- (1) Bala and David  
 (2) Aminah and Caden  
 (3) Bala, Caden and David  
 (4) All of the above

(Go on to the next page)

5. Two fruits of similar size, P and Q, were found growing on a plant. Mr Lee removed the food-carrying tubes from the stem of the plant between parts X and Y as shown. He placed the plant under the sun and continued to water it daily.

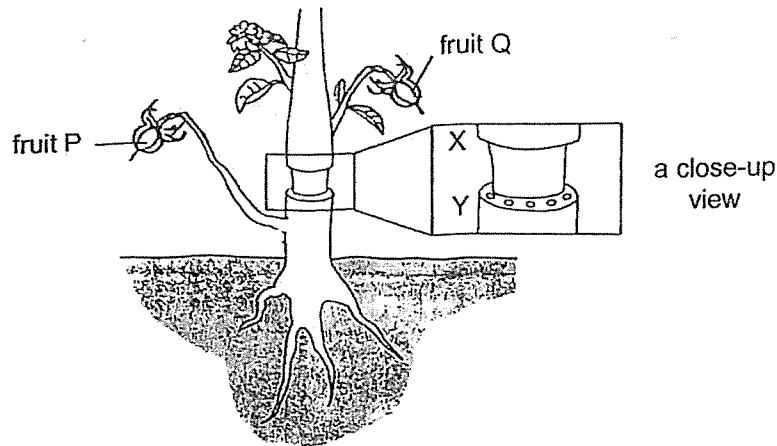

Which two observations would Mr Lee make about the plant after three weeks?

- A Fruit P was smaller than fruit Q.  
 B The stem was swollen at part X.  
 C The stem was swollen at part Y.  
 D The leaves of the plant turned yellow
- (1) A and B  
 (2) A and C  
 (3) B and C  
 (4) B and D
6. Which of the following two activities contribute to an increase in the amount of carbon dioxide in the air?
- A Using a bicycle to get around  
 B Clearing forest area to build factories  
 C Using reusable bags when going shopping  
 D Burning trash instead of dumping them into landfills
- (1) A and B  
 (2) B and C  
 (3) B and D  
 (4) C and D

(Go on to the next page)

7. Samuel conducted an experiment as shown.

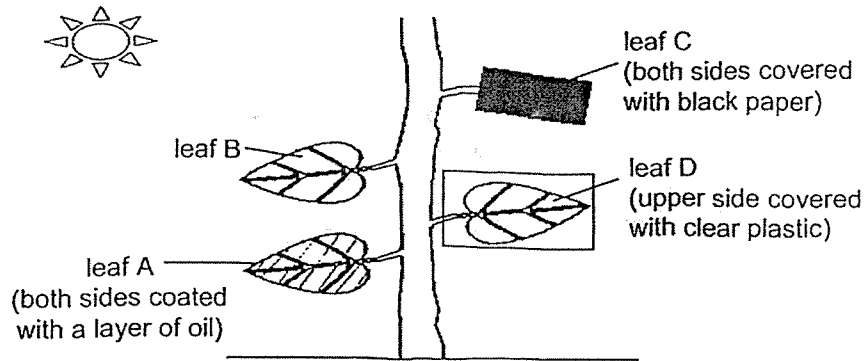

After five days, leaves A, B, C and D were tested for starch using iodine solution. Iodine solution will change from brown to blue-black in the presence of starch.

Which of the following shows the correct colour of the iodine solution on the different leaves?

	A	B	C	D
(1)	brown	blue-black	blue-black	brown
(2)	brown	blue-black	brown	blue-black
(3)	brown	brown	blue-black	blue-black
(4)	blue-back	brown	brown	brown

8. The diagram shows the cross-section of a pond with some plants.

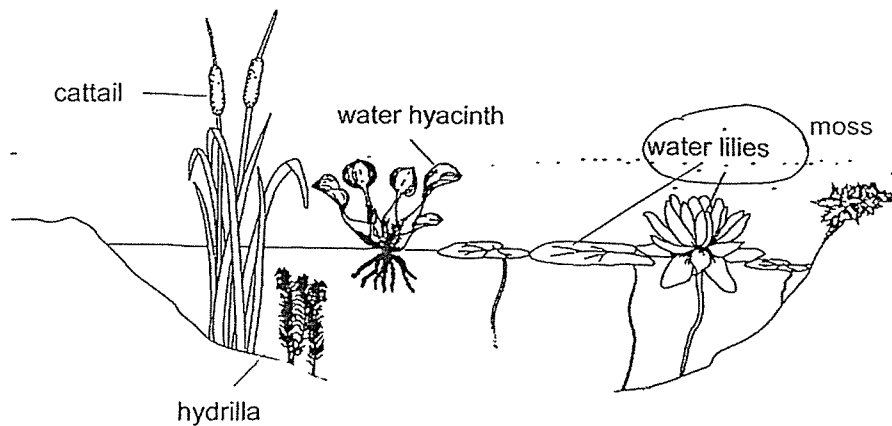

The population size of water lilies increased rapidly and covered the surface of the pond. Which plant would be most affected by this?

- (1) moss
- (2) cattail
- (3) hydrilla
- (4) water hyacinth

(Go on to the next page)

9. Allegra wanted to find out if the presence of water affects the growth of mould on bread.

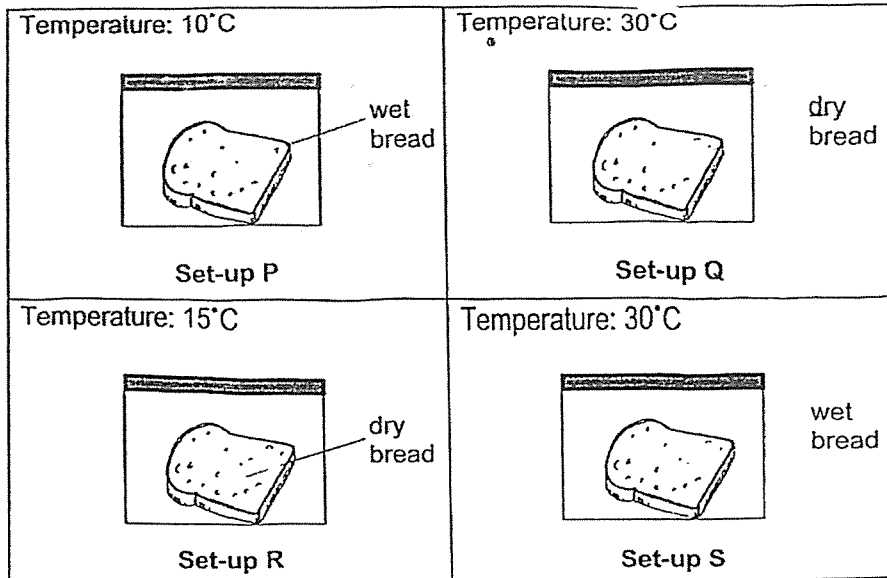

Which two set-ups should she use for her experiment?

- (1) P and R  
 (2) Q and S  
 (3) P and Q  
 (4) Q and R
10. The table shows the adaptations of four animals and how they help them.

Animal	Adaptation	How the adaptation helps them
whale	A	To reduce heat loss
platypus	B	To move in water and on land
mosquito larva	C	To obtain air
eagle	D	To be lighter for flight

Which of the following correctly represents A, B, C and D?

	A	B	C	D
(1)	body covering of hair	flippers	air bubble	streamlined body
(2)	layer of fat	webbed feet	breathing tube	hollow bones
(3)	body covering of hair	flippers	breathing tube	streamlined body
(4)	layer of fat	webbed feet	air bubble	hollow bones

11. Elias kept some flies in a container which had air holes and sufficient amount of food and water. He recorded the population of flies over a period of time in the graph. At some point in time, he placed a frog into the container.

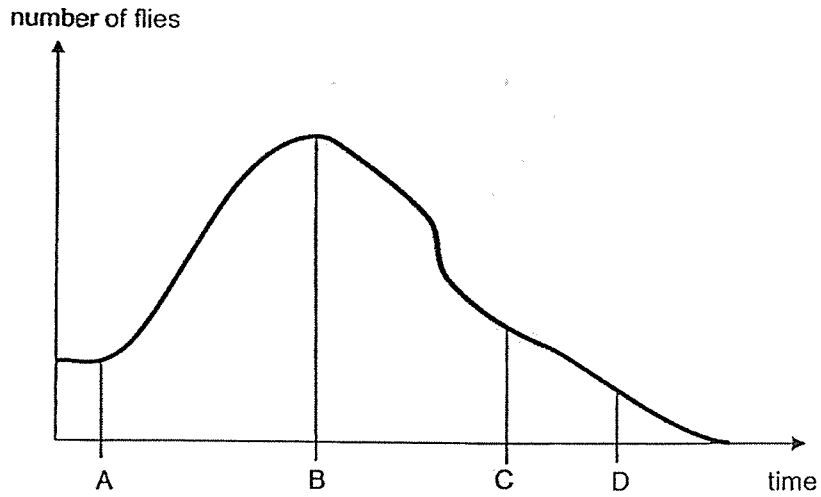

At which point in time, A, B, C or D, did he place the frog in the container?

- (1) A
  - (2) B
  - (3) C
  - (4) D
12. The diagram shows the stages in the life cycle of two animals, P and Q. Each box represents a stage in the life cycle.

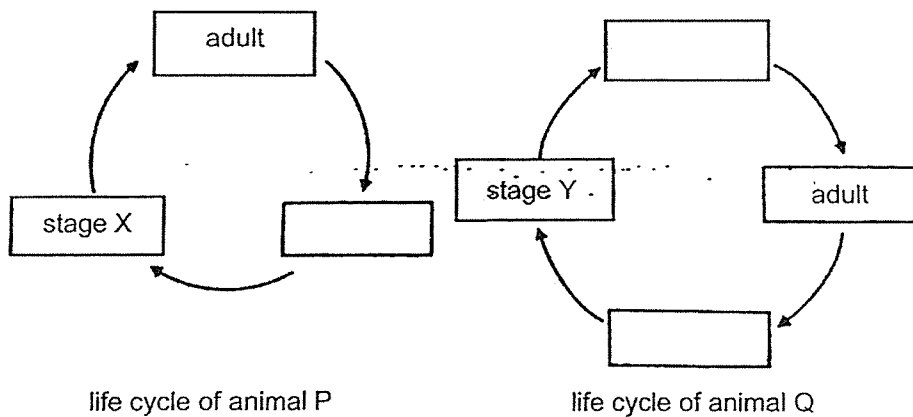

What are stages X and Y?

	stage X	stage Y
(1)	larva	nymph
(2)	nymph	pupa
(3)	nymph	larva
(4)	larva	pupa

(Go on to the next page)

13. The diagram shows an area in the forest where three types of plants,  $\blacktriangle$ ,  $\bullet$  and  $\star$ , were found.

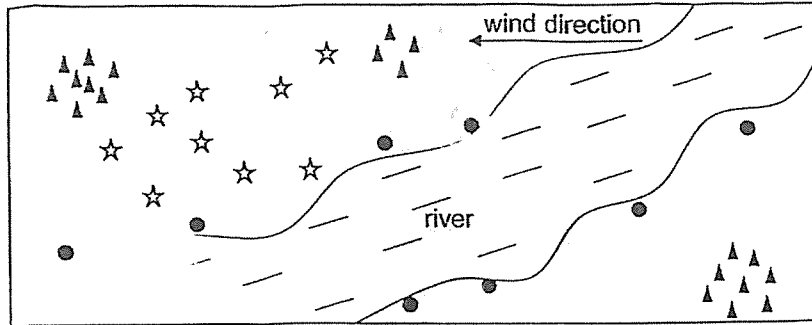

The fruits or seeds of the plants are dispersed by \_\_\_\_\_.

	$\blacktriangle$	$\star$	$\bullet$
(1)	wind	animal	splitting
(2)	splitting	wind	water
(3)	wind	splitting	water
(4)	splitting	animal	wind

14. The diagrams show the male and female human reproductive systems.

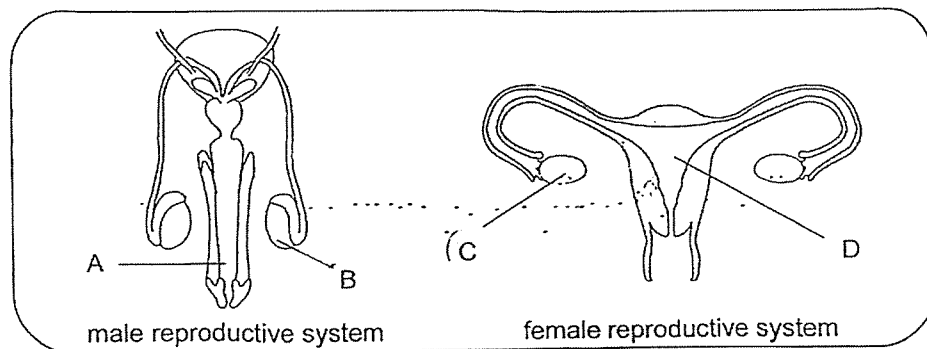

Which two parts of the reproductive systems produce cells that fuse during fertilisation?

- (1) A and C
- (2) A and D
- (3) B and C
- (4) B and D

(Go on to the next page)

15. Ali wanted to find out how a bar magnet interacts with three rods, W, X and Y.

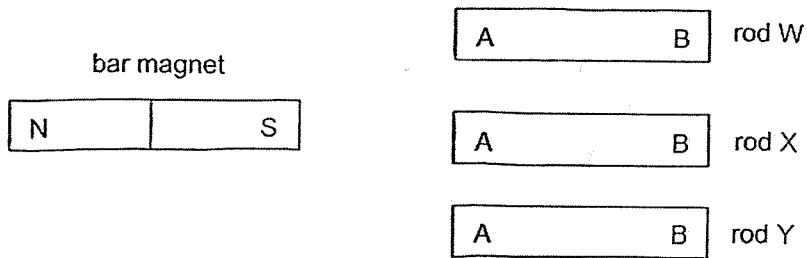

He brought the South-pole of the bar magnet near each end of the three rods and recorded his observations in the table.

Rod	Ends	Attract	Repel	No interaction
W	A			
	B			
X	A			
	B			
Y	A			
	B			

Which rod(s) is/are magnet(s)?

- (1) W only  
 (2) Y only  
 (3) W and X  
 (4) X and Y

(Go on to the next page)

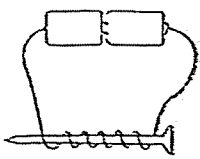
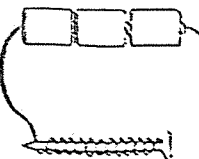
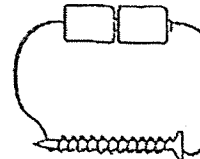
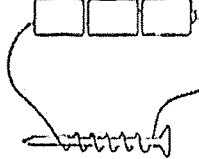

16. Bala made four electromagnets using identical batteries and nails as shown.

Electromagnet A	Electromagnet B	Electromagnet C	Electromagnet D
			
Number of coils of wire: 6	Number of coils of wire: 12	Number of coils of wire: 12	Number of coils of wire: 6

Which electromagnet will be able to attract the greatest number of steel pins?

- (1) A
- (2) B
- (3) C
- (4) D

17. In the circuit shown, four bulbs, B1, B2, B3 and B4 and four switches, S1, S2, S3 and S4 are connected to two identical batteries. All bulbs and batteries are in working condition.

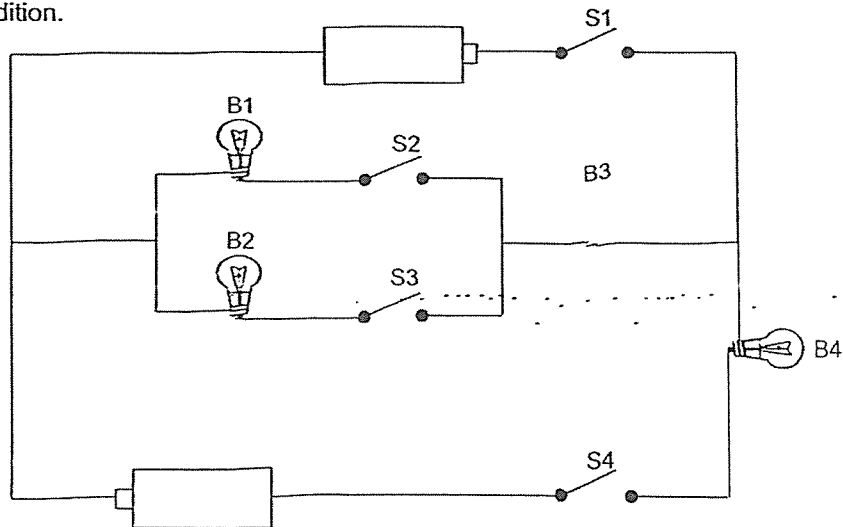

Which two switches should be closed so that the most number of bulbs will light up?

- (1) S1 and S2
- (2) S1 and S4
- (3) S2 and S3
- (4) S3 and S4

Go on to the next page

18. George set up the following circuit to find out if rods W, X, Y and Z are electrical conductors or insulators.

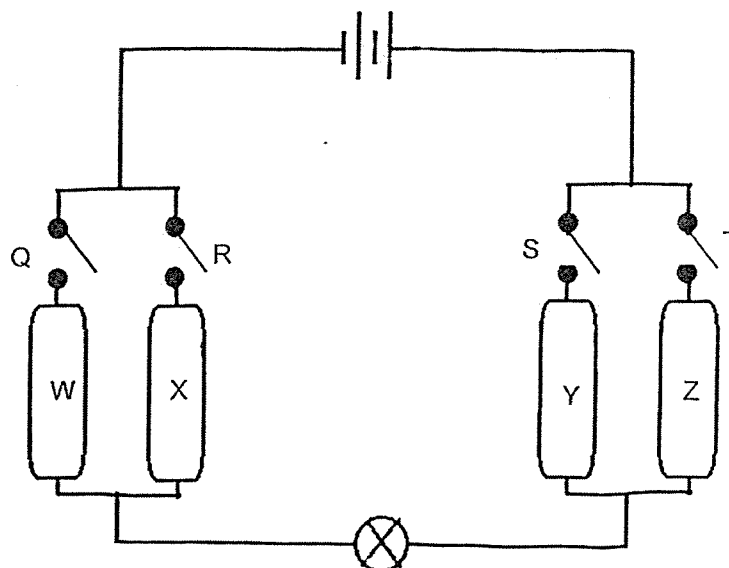

The table shows if the bulb lighted up when the different switches, Q, R, S and T, are closed.

Switches closed	Did the bulb light up?
Q and S	No
Q and T	Yes
R and S	No
R and T	Yes

What can be concluded about rods W, X, Y and Z?

	W	X	Y	Z
(1)	insulator	conductor	insulator	insulator
(2)	conductor	conductor	insulator	conductor
(3)	insulator	insulator	conductor	insulator
(4)	conductor	insulator	conductor	conductor

(Go on to the next page)

19. Which of the following is not a source of heat?

(1)



(2)

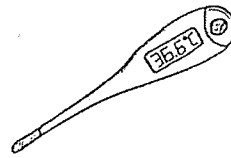

(3)



(4)

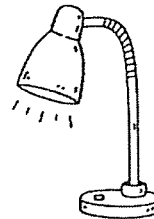

20. Muthu placed the same volume of wax at four points, W, X, Y, and Z, on a metal wire with sides of equal length as shown. When the metal wire was heated at a certain position, the wax began to melt in the order of W, X, Z and Y.

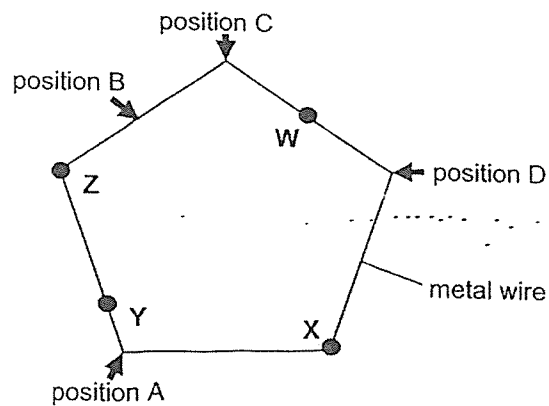

At which position, A, B, C or D, was the wire heated at?

- (1) A
- (2) B
- (3) C
- (4) D

(Go on to the next page)

21. Janet placed a canned drink at room temperature into a basin of cold water with crushed ice as shown.

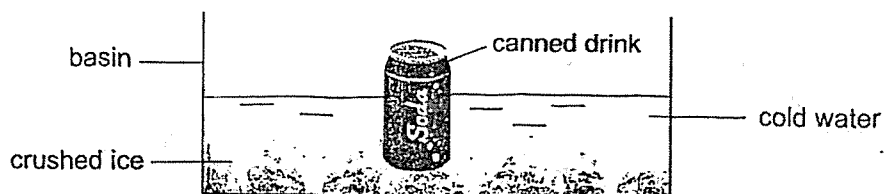

Which two statements are true?

- A The ice gained heat from the cold water.
- B The cold water lost heat to the surrounding air.
- C The canned drink lost heat to the cold water and ice.
- D The temperature of the canned drink and ice increased.

- (1) A and C
- (2) A and D
- (3) B and C
- (4) B and D

22. Hugo placed a dish and a flask, both with the same mass and same volume of tap water, onto a balance.

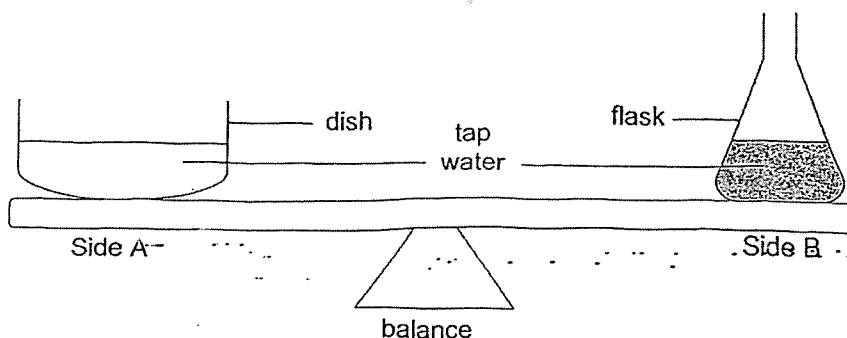

Which is the correct observation and explanation after two hours?

	Observation	Explanation
	Side A will tilt downwards.	More water from the dish had evaporated.
(2)	Side A will tilt downwards.	The dish has a bigger volume than the flask.
(3)	Side B will tilt downwards.	Less water from the flask had evaporated.
(4)	The beam will remain balanced.	The same volume of water evaporated from the dish and flask.

23. James set up an experiment to represent the water cycle.

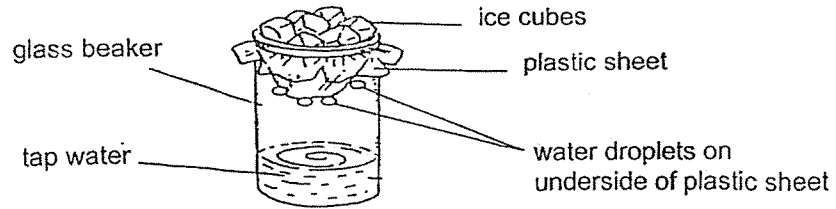

Which of the following change when made to the set-up will most likely increase the rate of condensation on the underside of the plastic sheet?

- (1) Add more tap water
  - (2) Replace the tap water with hot water
  - (3) Replace the ice cubes with cold water
  - (4) Replace the glass beaker with a plastic beaker
24. Caleb released a box down a ramp with surface P. He recorded the time taken for the box to reach the bottom of the ramp.

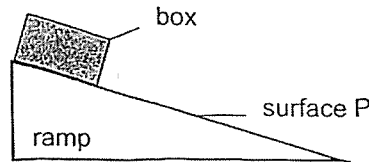

Caleb repeated the experiment on three identical ramps with different surfaces, Q, R and S. He recorded the results in the table.

Surface	Time taken for box to reach the bottom of the ramp (s)
P	5
Q	20
R	15
S	10

There was most friction between the box and surface \_\_\_\_\_.

- (1) P
- (2) Q
- (3) R
- (4) S

(Go on to the next page)

25. David placed a steel toy car on a thin piece of plank made of three different surfaces as shown. He applied a force continuously to the toy car till the end of the plank.

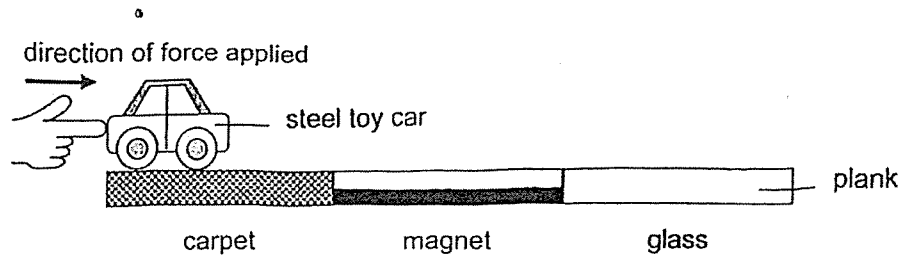

Which graph best shows the amount of force needed to push the toy car on the three different surfaces of the plank?

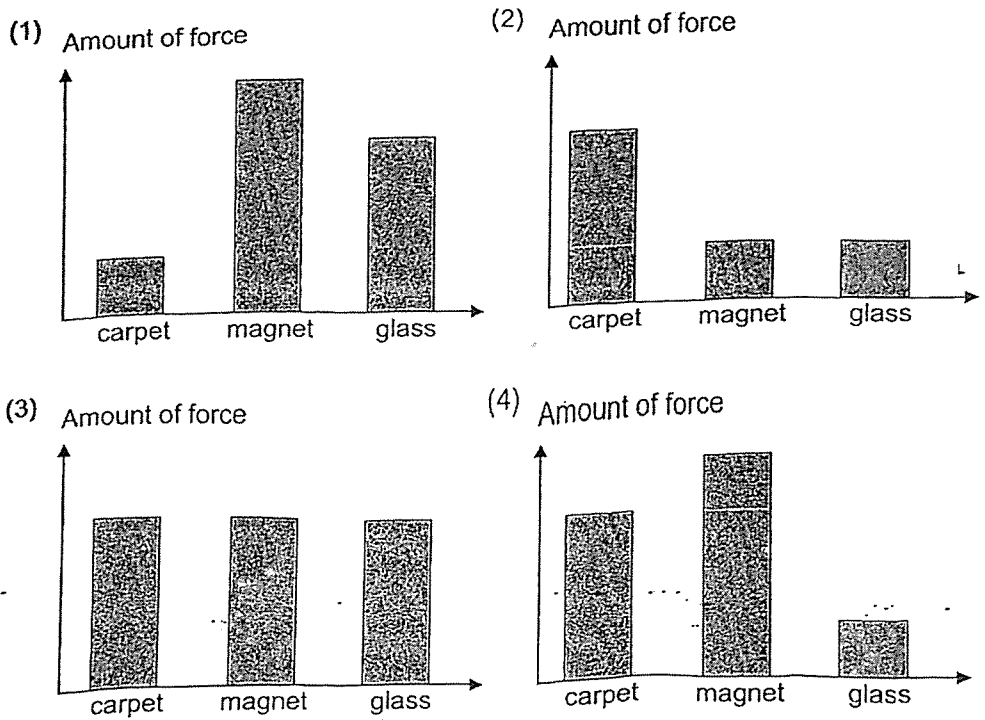

(Go on to the next page)

26. Frank attached two identical syringes, each with a capacity of  $50 \text{ cm}^3$ , to a container with a capacity of  $200 \text{ cm}^3$  as shown.

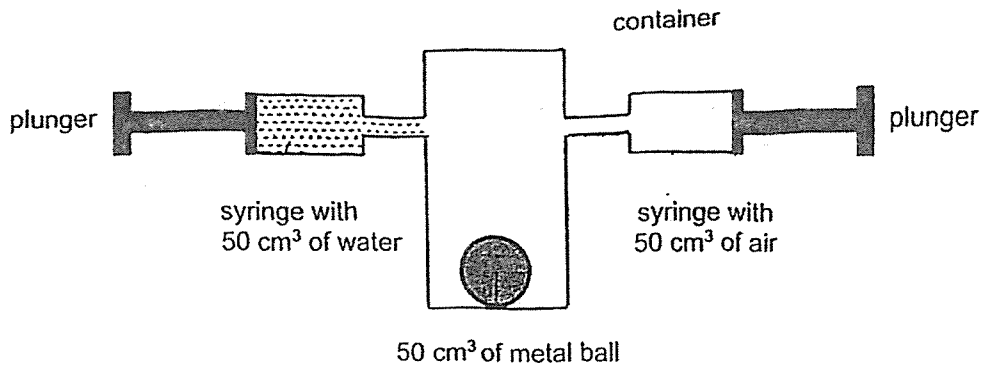

What will be the volumes of metal ball, water and air in the container when both plungers are completely pushed in?

	Volume (cm <sup>3</sup> )		
	metal ball	water	air
(1)	50	50	50
(2)	50	50	150
(3)	50	50	100
(4)	40	40	120

27. Charlotte dropped a tennis ball from a certain height. The tennis ball bounced a few times on the floor before coming to a stop.

Which of the following graphs correctly shows the change in the amount of potential energy of the tennis ball from the time she dropped it till it stopped moving?

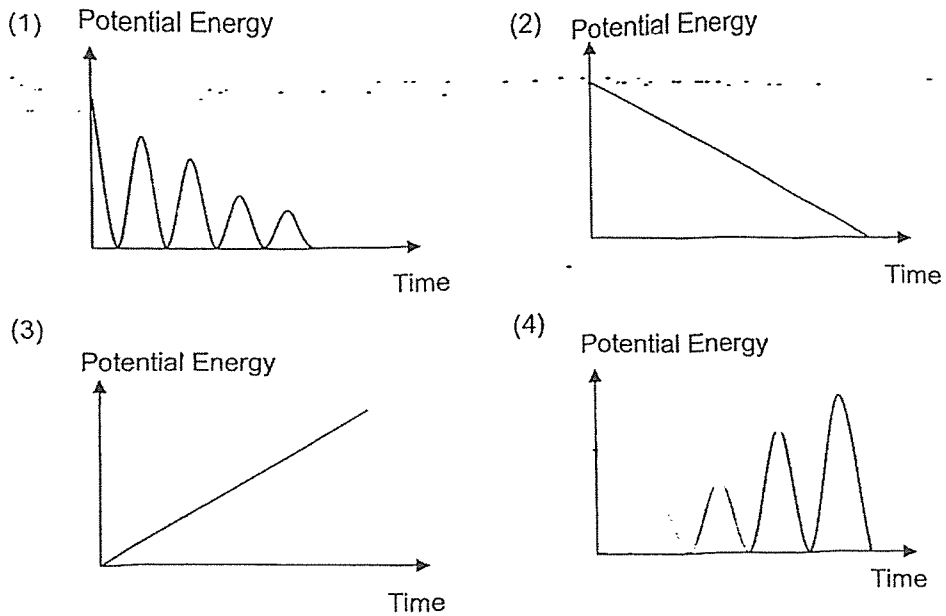

(Go on to the next page)

28. Farah set up the experiment as shown in diagram 1. A torch is shone on three objects M, N, and O which are made of different materials. The objects are of the same height but have different shapes.

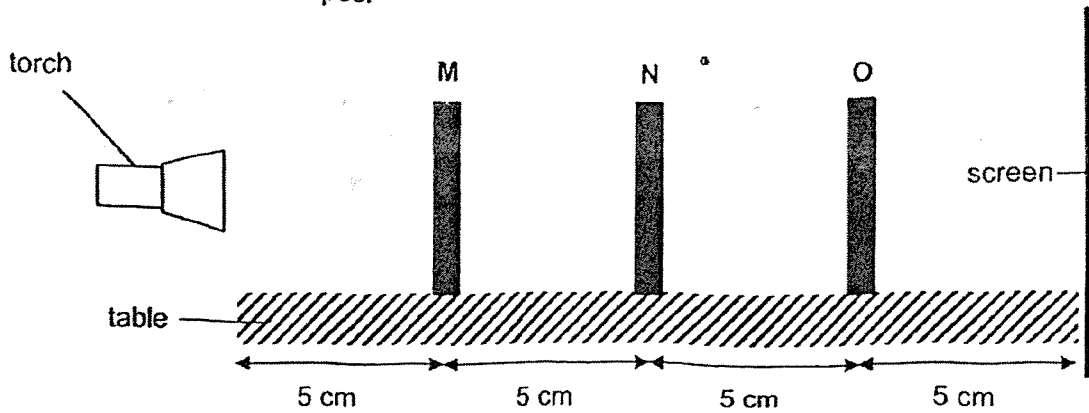

Diagram 1

Diagram 2 shows the front view of the three objects.

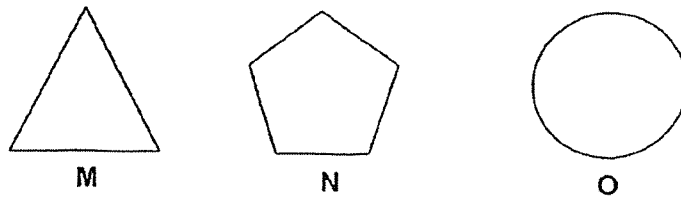

Diagram 2

The table shows the material that each object is made of.

Shape	Material
M	Clear plastic
N	Tracing paper
O	Cardboard

Which shadow was cast on the screen?

(1)

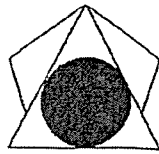

(2)

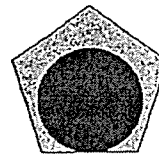

(3)



(4)



(Go on to Booklet B)



**Booklet B: 44 marks**

For questions 29 to 40, write your answers in this booklet.

The number of marks available is shown in brackets [ ] at the end of each question or part question.

29. The diagram shows four different blood vessels, A, B, C and D with different amount of bad cholesterol. Bad cholesterol is a waxy substance that can build up in the walls of blood vessels. It leads to a decrease in the rate of blood flow through the blood vessels.

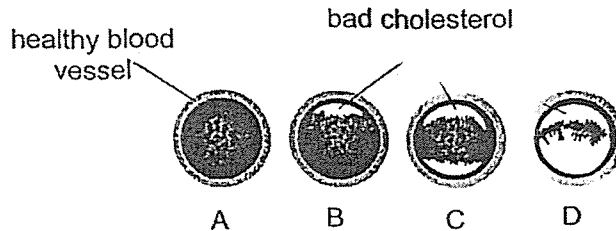

The table shows the rate of blood flow through the blood vessels.

Rate of blood flow (litres/ minute)	Blood vessel			
	A	B	C	D
	5	4.5	4	1

- (a) State the relationship between the amount of bad cholesterol present in the blood vessel and the rate of blood flow. [1]

\_\_\_\_\_

\_\_\_\_\_

A heart attack happens when blood flow to the heart is blocked or cut off. When there is insufficient oxygen-rich blood flowing to the heart, it may cause damage to the heart.

- (b) Which blood vessel, A, B, C or D, will cause a person to have the highest chance of getting a heart attack? Explain your choice based on the information in the question. [2]

\_\_\_\_\_

\_\_\_\_\_

\_\_\_\_\_

\_\_\_\_\_

Please do not write in the margin.

Please do not write in the margin.

30. The diagram shows the average distance the seeds are dispersed from plant R. The seeds of Plant R are dispersed by splitting. Some seeds are further dispersed by ants.

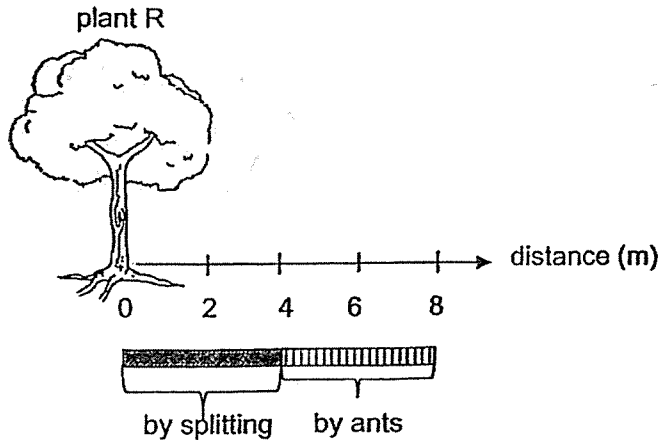

Please do not write in the margin.

(a) Describe how the fruit of plant R is dispersed by splitting. [1]

---



---

(b) Explain how ants help with the dispersal of seeds. [2]

---



---



---



---

The seed of plant R is shown in the diagram.



(c) Ants carry the seeds of plant R back to their nest. State how this is beneficial to the ants. [1]

---



---

Please do not write in the margin.

ACS J

31. Mark collected 100ml of water samples, A, B, C and D, from four different sources. He used a sensor connected to a data logger to measure the amount of dissolved oxygen in each water sample and recorded the results in the table.

Water sample	A	B	C	D
Amount of dissolved oxygen (units)	6	10	20	2

- (a) Which water sample would Mark likely find the largest number of underwater plants? Explain your choice. [1]

---



---

- (b) Company P released substance Y into the water source where water sample B was collected. Substance Y absorbs carbon dioxide and does not harm any organisms.

A week later, dead fish were seen floating on the surface of the water source. Explain why the fishes died. [2]

---



---



---



---

Please do not write in the margin.

Please do not write in the margin.

- 32 Plants need nutrients to grow well. Plant V as shown, grows in areas where there are low amounts of nutrients in the soil. It obtains nutrients from insects that it traps using its leaves.

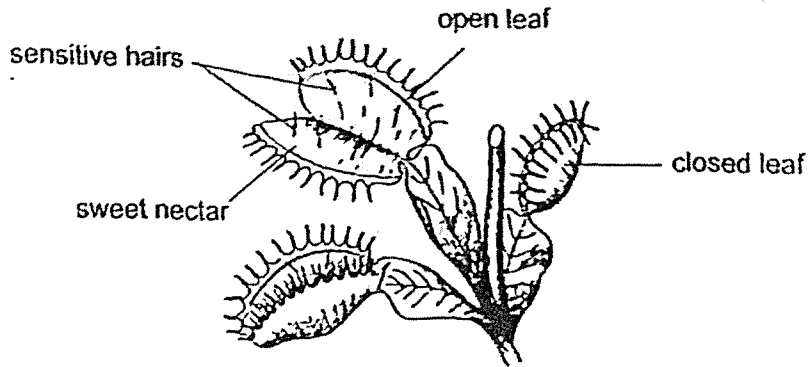

Plant V

When an insect touches two or more of the sensitive hairs of an open leaf, the leaf closes and traps the insect inside it.

- (a) For each of the following, name the type of adaptation. [1]

Sweet nectar: \_\_\_\_\_

Closing of the leaf: \_\_\_\_\_

- (b) State how the sweet nectar in the leaf is beneficial to plant V. [1]

\_\_\_\_\_

- (c) The flowers of plant V grow on tall stalks far above the leaves as shown.

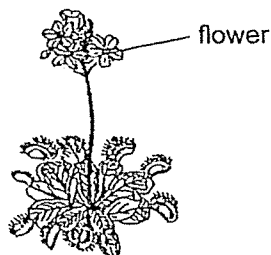

Give a reason why it is advantageous for plant V to have the flowers far above the leaves. [1]

\_\_\_\_\_  
\_\_\_\_\_

Please do not write in the margin.

Please do not write in the margin.

ACS

33. Nicholas used an inflated rubber balloon and pressed it with his hand as shown. He observed that the balloon changed shape but did not burst.

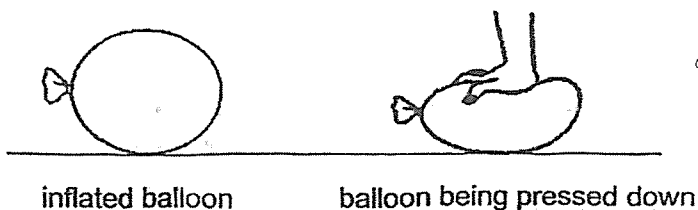

(a) Give a reason why the balloon can be pressed down without bursting. [1]

---



---

Please do not write in the margin.

Nicholas made a toy as shown to represent a human respiratory system.

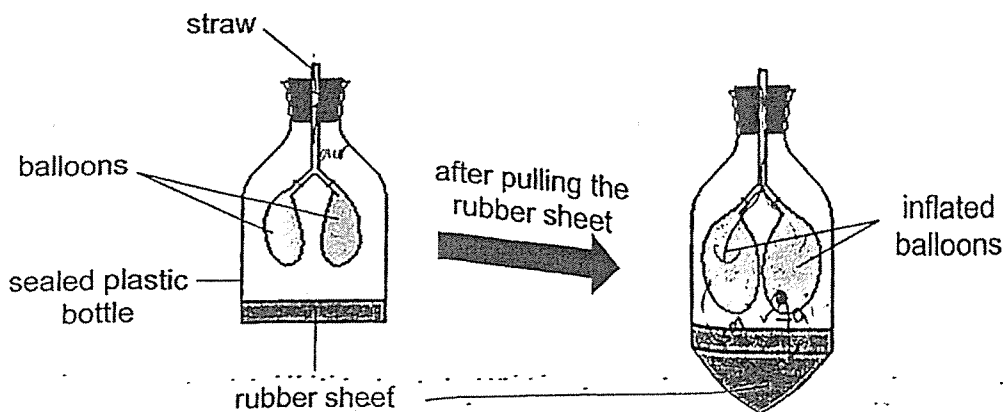

Please do not write in the margin.

As Nicholas gently pulled on the rubber sheet, he observed that the balloons inflated.

(b) Explain, in terms of properties of matter, why the balloons inflated when Nicholas pulled the rubber sheet. [2]

---



---



---



---

SCORE	3
-------	---

34. Mike wanted to find out if the presence of water on a metal block affects how fast the temperature of the metal block changes. He placed two identical metal blocks A and B, which were heated up to 80°C, in a room. He sprayed water onto metal block B as shown.

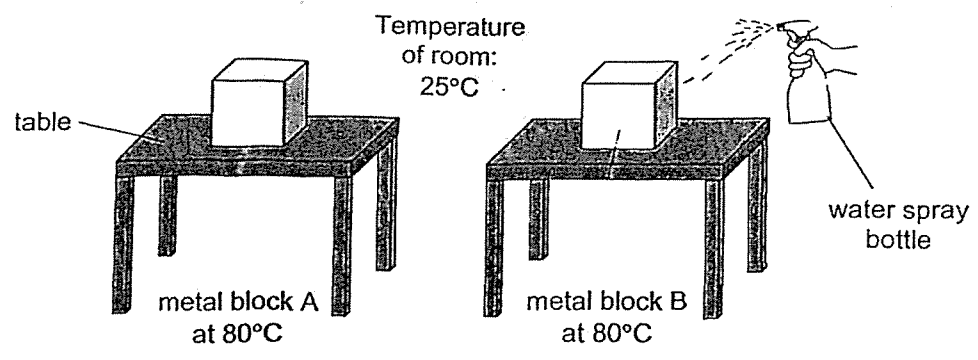

After Mike sprayed some water on metal block B, he used a heat sensor to measure the temperature of the metal blocks over 8 minutes and recorded his results in the table.

Time (min)	0	2	4	6	8	10
Temperature of metal block A (°C)	80	66	56	49	45	43
Temperature of metal block B (°C)	80	59	47	39	34	30

Please do not write in the margin.

Please do not write in the margin.

(a) Based on the results of the experiment, what can Mike conclude? [1]

---



---

(b) Mike observed that the water droplets on metal block B disappeared after some time. Explain why the water droplets on metal block B disappeared. [1]

---



---

(c) Without reheating the metal block, suggest a way to make the water droplets disappear faster. [1]

---



---

On hot days, cats are seen licking themselves more frequently. Licking spreads their saliva over their body.



(d) Explain how licking helps cats to keep cool on hot days.

[1]

---

---

Please do not write in the margin.

Please do not write in the margin.

SCORE	1
-------	---

35. Farmers use pesticides to protect their crops such as fruits and vegetables from insects and fungal diseases.

(a) While pesticides are useful in protecting crops, state a negative impact the pesticides have on human. [1]

---

---

Rachel investigated the effectiveness of different ways of washing vegetables to remove pesticides.

She prepared two identical sets of 200g of vegetables and 500 ml of water in similar containers. She added 50g of baking soda to one of the containers. Using similar pesticide test kits, she calculated the percentage of removed pesticides after employing the different washing methods for 30 seconds and then for 1 minute.

The results are as shown.

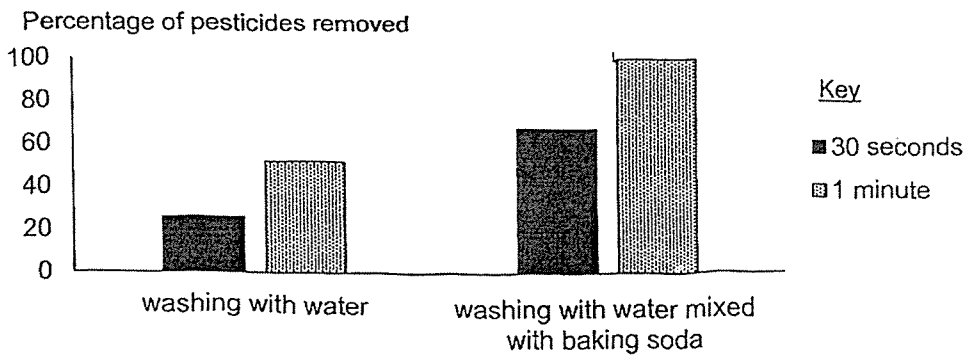

Please do not write in the margin.

Please do not write in the margin.

(b)(i) State what Rachel can conclude about the effectiveness of the different ways of washing vegetables in removing pesticides. [1]

---

---

(b)(ii) Explain your answer in (b)(i). [2]

---

---

---

SCORE	4
-------	---



36. Mdm Kareena sets up an electrical maze toy as shown. A metal ring moves from point X to point Y or vice versa. The metal ring is connected to a bulb and a buzzer such that when the metal ring touches the wire maze, the bulb will light up and the buzzer will ring.

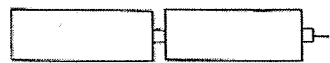
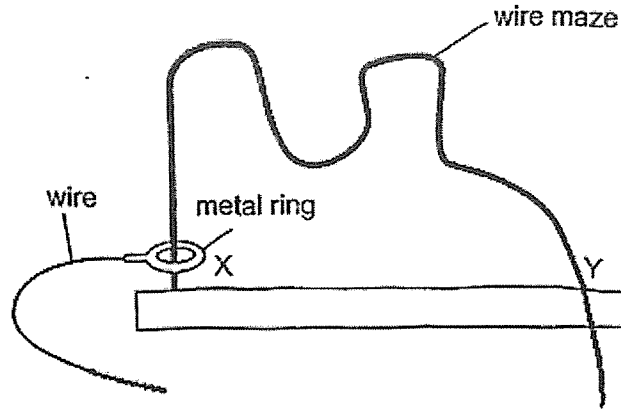

buzzer

Please do not write in the margin.

Please do not write in the margin.

- (a) Given that the buzzer will still work even when the bulb has fused, complete the circuit above. [2]
- (b) Explain why the bulb lights up and the buzzer rings when the metal ring touches the wire maze. [1]
- \_\_\_\_\_
- \_\_\_\_\_
- (c) Suggest what Mdm Kareena can do to make the bulb of the toy shine brighter and the buzzer ring louder. [1]
- \_\_\_\_\_
- \_\_\_\_\_

SCORE	4
-------	---

37. Lionel conducted an experiment by bringing an electromagnet near some iron pins and recorded the number of pins attracted to the electromagnet at different distances.

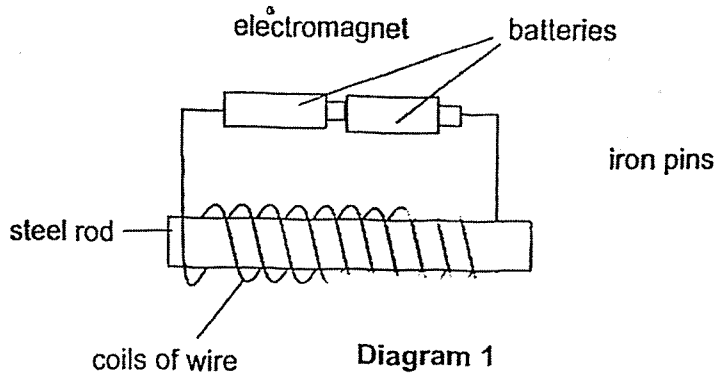

Distance between electromagnet and the iron pins (cm)	Number of iron pins attracted
20	17
50	9
100	0

- (a) Lionel kept the number of coils of wire around the steel rod the same. State how this ensures a fair test. [1]

---



---

- (b) Using the same number of batteries, state a change that Lionel can make to the electromagnet to attract more iron pins at a distance of 50 cm. [1]

---



---

Please do not write in the margin.

Please do not write in the margin.

Lionel used a conveyor belt system with an electromagnet which is between point A and B. Part of the system is shown in **diagram 2**. As the conveyor belt moves in the direction of the arrows, cans in the box are separated based on the materials they are made of.

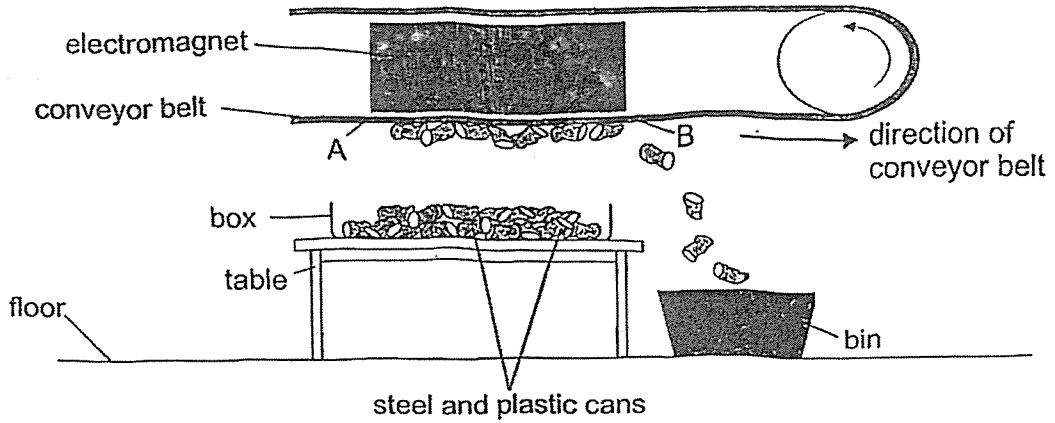

**Diagram 2**

(c) Explain how the cans are separated and deposited in the bin. [2]

---



---



---



---

(d) Lionel removed the table in diagram 2 and placed the box of cans on the floor as shown in diagram 3. The position of the conveyor belt system did not change.

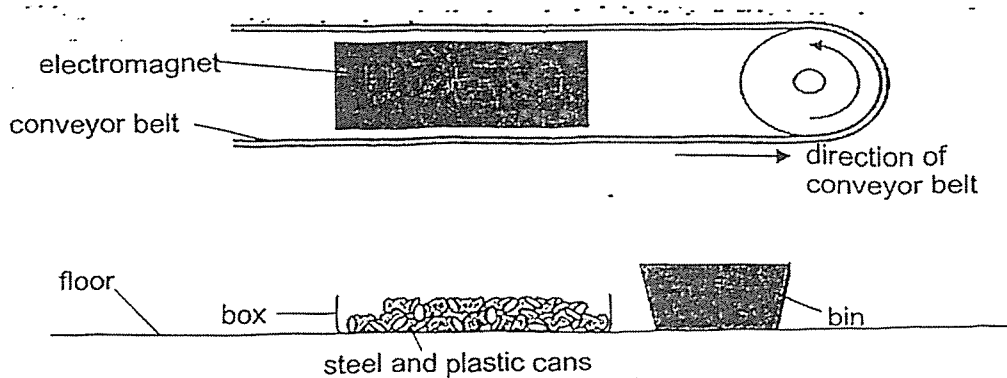

**Diagram 3**

Give a reason why the conveyor belt system was no longer able to separate the cans. [1]

---

Please do not write in the margin.

Please do not write in the margin.

SCORE	3
-------	---

38. Peter conducted an experiment using the set-up as shown. When he released the toy car, it moved across the table. He recorded the time taken for the toy car to reach the end of the table.

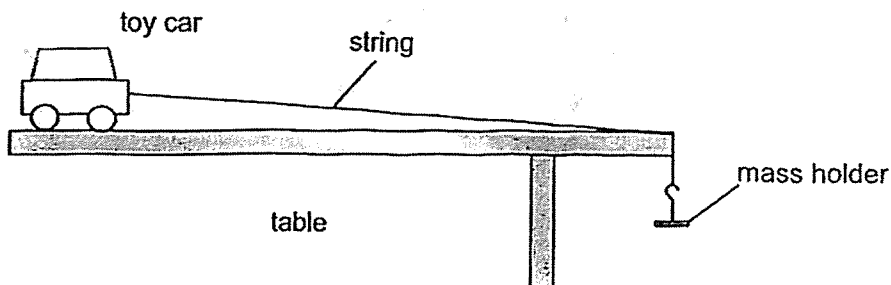

Please do not write in the margin.

- (a) Peter repeated the experiment by continuously adding slotted masses to the mass holder and observed that the toy car moved faster. Explain why, in terms of forces. [1]

---



---

- (b) Peter noticed that the string was rubbing against the edge of the table as the toy car was being pulled down the by the masses. After repeating the experiment a few times, the string broke.

Explain why the repeated rubbing of the string against the edge of the table caused the string to break. [1]

---



---

- (c) Suggest what Peter can do to obtain more reliable results. [1]

---



---

Please do not write in the margin.

SCORE	3
-------	---

39. Hussein conducted an experiment using three similar containers made of different materials, S, T and U. He placed 100 ml of water at 85°C into each container as shown.

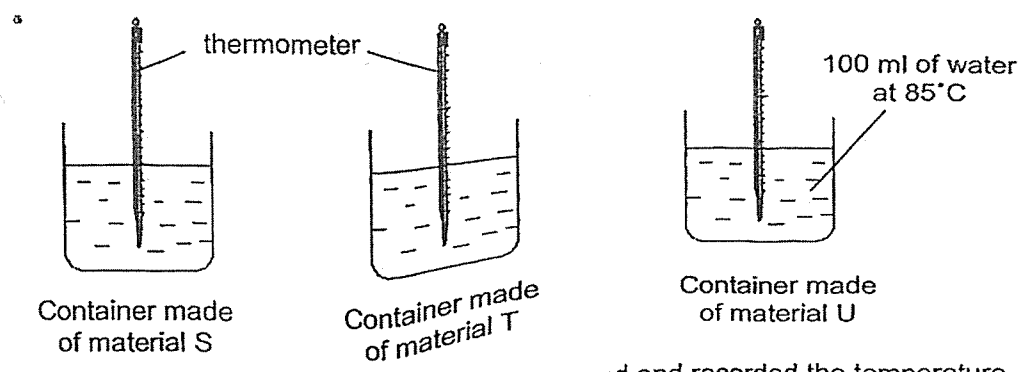

He left the containers on the kitchen table. He measured and recorded the temperature of water in each container for 30 minutes in the graph.

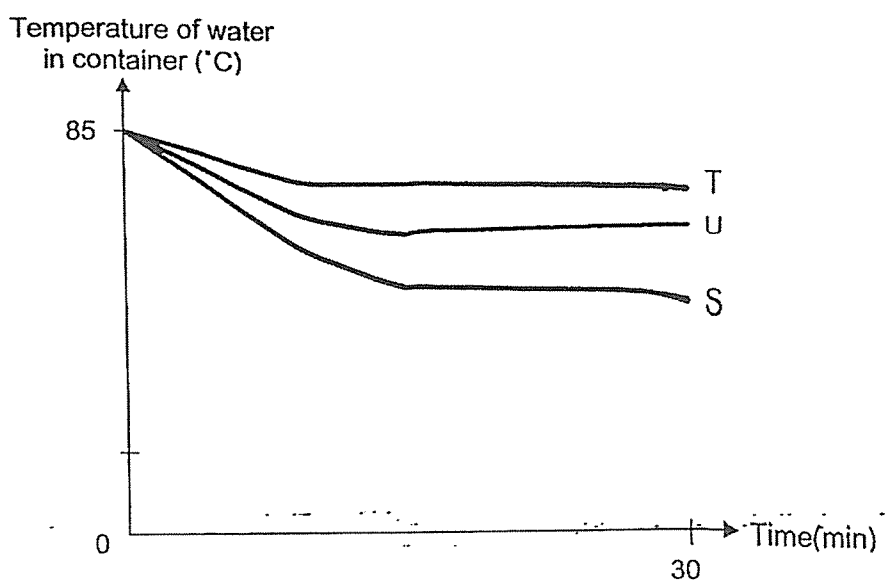

Please do not write in the margin.

Please do not write in the margin.

(a) Which material, S, T or U, should be used to keep coffee hot for the longest period of time? Explain your answer based on the graph. [1]

---



---

(b) What would happen to the temperature of the water in all the containers after three hours? [1]

---

SCORE	2
-------	---

Hussein noticed that a cardboard sleeve is wrapped around a cup of hot coffee for customers to take away. The diagram shows the side view and top view of the cup with the cardboard sleeve.

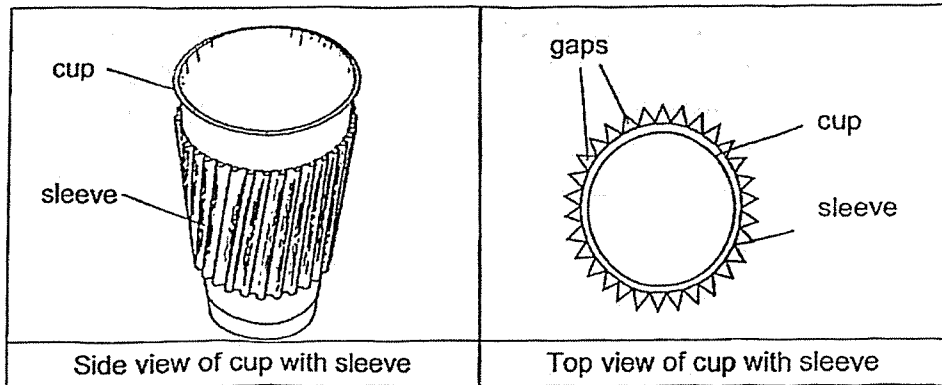

Please do not write in the margin.

Hussein's hands felt less hot when he held the cup of coffee wrapped with the cardboard sleeve as compared to the cup of coffee without the cardboard sleeve.

(c)(i) Explain why his hands felt less hot when he held the cup of coffee wrapped with the cardboard sleeve. [2]

---



---



---

Please do not write in the margin.

Hussein bought two cups of coffee, A and B, of different sizes as shown. The coffee in the cups were at 85°C.

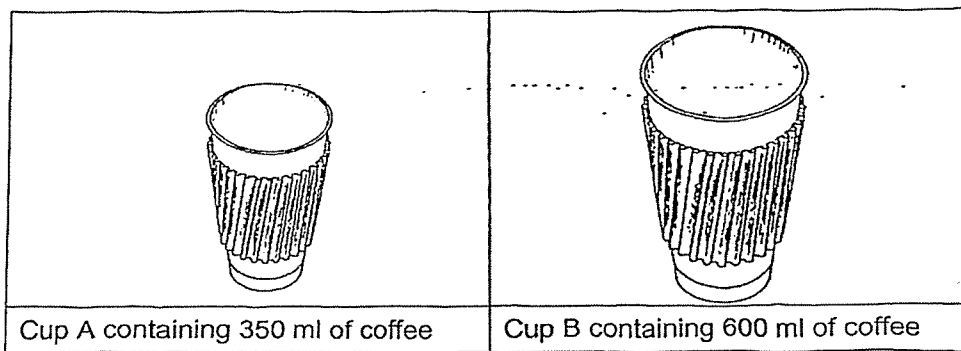

He then placed the same amount of ice cubes into each cup to cool the coffee.

(c) (ii) In which cup, A or B, would the ice cubes melt faster? Give a reason for your answer. [1]

---



---

40. The diagram shows a solar-powered toy car. The solar panel traps light energy from the sun, causing the toy car to move.

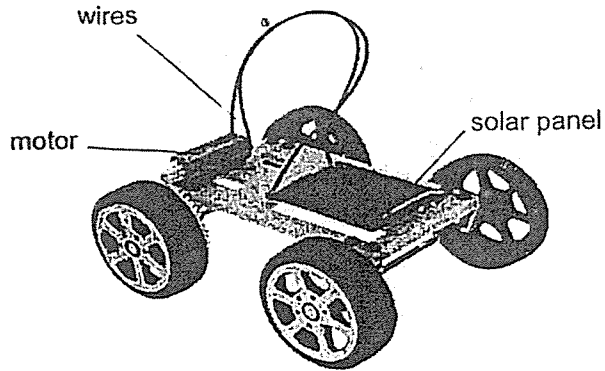

- (a) State the main energy conversion for the toy car to work. [1]

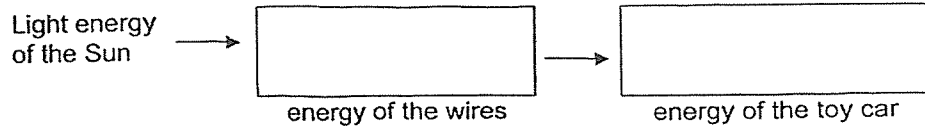

Apart from manufacturing fuel-powered cars, some car companies have also been manufacturing solar-powered cars to reduce air pollution.

- (b) State what pollution is. [1]

---



---

- (c) Other than reducing air pollution, state another advantage of using solar-powered cars over fuel-powered cars. [1]

---

End of Paper

Please do not write in the margin.

Please do not write in the margin.

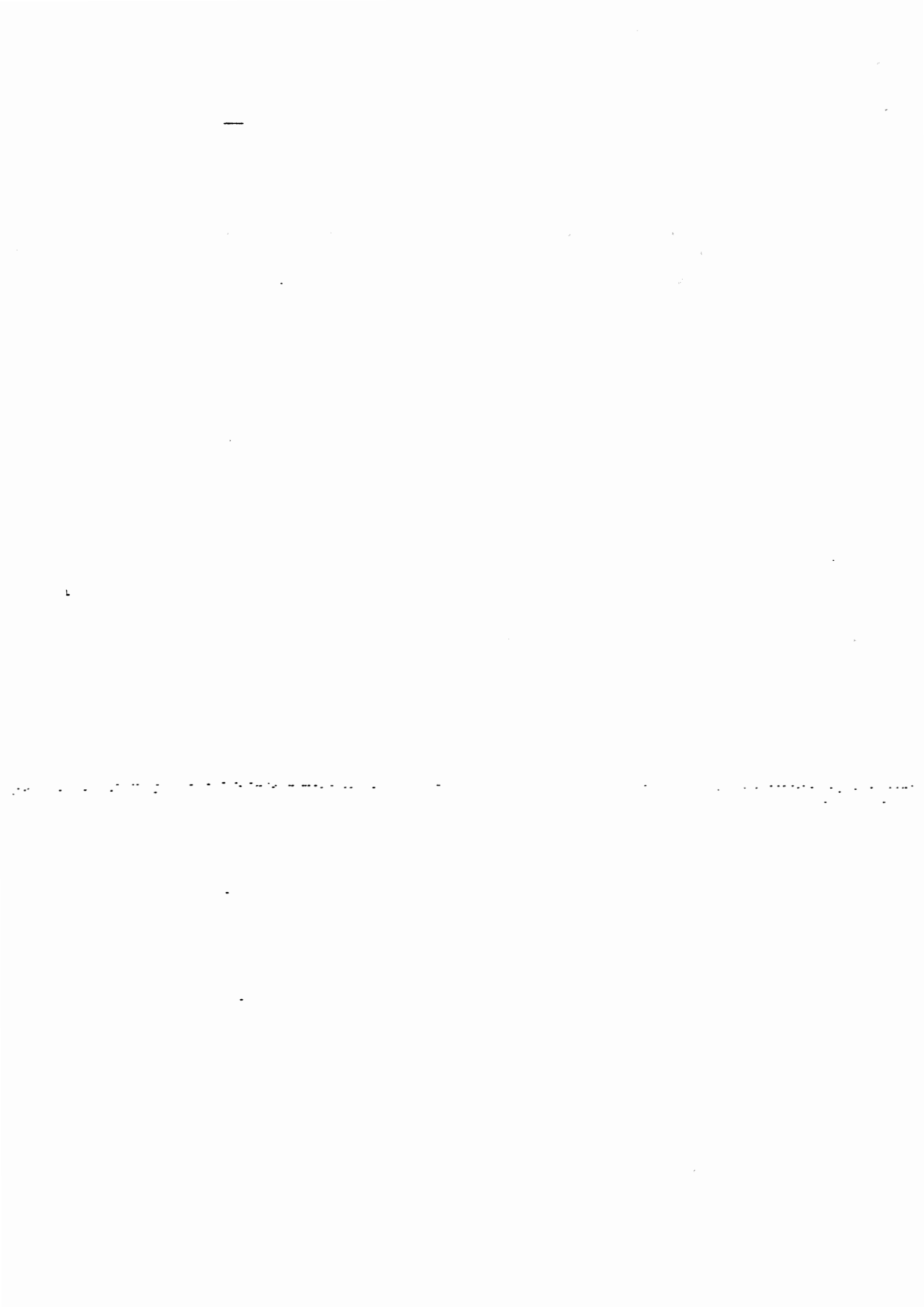



**SCHOOL : ACS (JUNIOR) PRIMARY SCHOOL**  
**LEVEL : PRIMARY 6**  
**SUBJECT : SCIENCE**  
**TERM : 2023 PRELIM**

**SECTION A**

Q 1	Q2	Q3	Q4	Q5	Q6	Q7	Q8	Q9	Q10
2	4	4	3	1	3	2	3	2	2
Q 11	Q12	Q13	Q14	Q15	Q16	Q17	Q18	Q19	Q20
2	3	2	3	2	2	4	2	2	4
Q 21	Q22	Q23	Q24	Q25	Q26	Q27	Q28		
1	3	2	2	4	3	1	2		

**SECTION B**

Q29a)	As the amount of bad cholesterol present in the blood vessel increases, the rate of blood flow decreases.
Q29b)	D. Blood vessel D has the highest amount of bad cholesterol build up in it, leading to lowest rate of blood flow through the blood vessel. This blood vessel has the highest chance of being clogged with insufficient oxygen rich blood flowing to the heart, leading to a heart attack.
Q30a)	Fruit of plant R has fruit wall that splits open when ripe. The seeds inside plant R are then flung out with force, dispersing seeds by splitting.
Q30b)	After the seeds of plant R are dispersed by splitting, some sweet-smelling, juicy flesh stuck to the seeds attracts ants to eat it. Ants will carry the seed further away from the parent plant, reducing competition for sunlight, space, water and minerals.
Q30c)	The ants would be able to feed their young in their nest.
Q31a)	C. C has the highest amount of dissolved oxygen, which likely means it has the most underwater plants photosynthesising to produce oxygen.
Q31b)	Plants need carbon dioxide to photosynthesise. Since substance Y absorbs carbon dioxide, there would be less carbon dioxide available for the underwater plants and underwater plants would photosynthesise less, producing less dissolved oxygen. After a week, the amount of dissolved oxygen is no longer enough for fishes to respire and they died.

Q32a)	Sweet nectar: structural adaptation Closing of the leaf: behavioural adaptation
Q32b)	The sweet nectar attracts insects to plant V, which plant V can then trap and obtain nutrients from for it to grow well.
Q32c)	This ensures that insects that pollinate the flowers do not get trapped in the leaves of plant V.
Q33a)	The balloon was filled with air which can be compressed.
Q33b)	When the rubber sheet is pulled, the volume of the sealed plastic bottle increases. However, the volume of air in the sealed plastic bottle is fixed, hence surrounding air enters the balloon through the straw to occupy additional space inside the plastic bottle, inflating the balloons.
Q34a)	The presence of water on a metal block decreases temperature of metal block at a faster rate.
Q34b)	The water droplets gain heat from metal block B and evaporated into water vapour.
Q34c)	Decrease temperature of room/place block under the Sun.
Q34d)	The saliva on cat's body will gain heat from the cat's body to evaporate into water vapour, thus reducing the heat on cat's body to keep cat cool.
Q35a)	Pesticides sprayed onto crops may not be washed away properly, leading to poisoning of humans who consume it.
Q35b)	Washing vegetables with water mixed with baking soda is more effective than washing with water only in removing pesticides.
Q35c)	There is a higher percentage of pesticides removed when water is mixed with baking soda regardless of duration.
Q36a)	

Q36b)	When metal ring touches the wire maze, it forms a closed circuit, allowing electricity to pass through. Hence bulb lights up and buzzer rings.
Q36c)	Increase number of batteries.
Q37a)	Keeping the number of coils constant ensures that magnetic force of electromagnet is constant, ensuring a fair test.
Q37b)	increase number of coils of wire around steel rod/use lighter iron pins
Q37c)	The steel cans are magnetic while the plastic cans are non-magnetic. Hence, the steel cans will be attracted to the electromagnet, separating it from the plastic cans, travelling along the conveyor belt until it moves past the electromagnet, where it will drop into the bin.
Q37d)	The distance between the steel cans and the electromagnet is too far for the electromagnet to attract the steel cans.
Q38a)	When more slotted masses are added, the combined mass in the mass holder increases, increasing the pull force on the toy car, making it easier to overcome the friction between the toy car and table.
Q38b)	There is friction present between the string and the edge of the table, causing wear and tear of the string, leading it to break.
Q38c)	Repeat experiment three times.
Q39a)	T. The temperature decrease of water in T is the least and T is able to retain the highest temperature for the water out of the three materials.
Q39b)	Water would reach room temperature.
Q39ci)	There are air spaces between the sleeves and the hands. As air is a poor conductor of heat, it slows down the heat gain from the hot coffee to the hands, thus his hands felt less hot.
Q39cii)	B. It has a larger volume of coffee which means it has more heat, hence the ice cubes would gain heat faster from the hot coffee, causing it to melt faster.
Q40a)	Electrical energy → kinetic energy
Q40b)	Pollution is the release of harmful substances into the land, water or air.
Q40c)	Solar powered cars reduce dependence on fossil fuels, which is a finite resource. / It is a renewable source of energy.

—

L

S

X

-----

.

.

.

.