

RED SWASTIKA SCHOOL  
SCIENCE  
PRIMARY 4  
CLASS TEST (2)

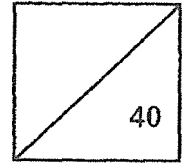

Name: \_\_\_\_\_ ( )

Parent's Signature: \_\_\_\_\_

Class: Pr. 4 \_\_\_\_\_

Date: \_\_\_\_\_

Total time for Section A and B: 50 minutes

**Section A: Multiple-Choice Questions (14 x 2 = 28 marks)**

For Questions 1 to 14, choose the most suitable answer and shade its number in the OAS provided.

1. John touched a snail as shown in the diagram below. The snail pulled its head into its shell.

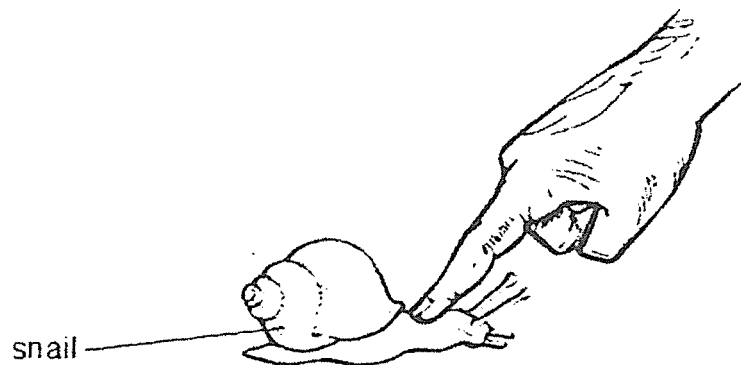

What could John conclude about living things from his observation?

- (1) Living things grow.
- (2) Living things reproduce.
- (3) Living things respond to changes.
- (4) Living things need air, food and water.

2. The following table shows the characteristics of three living things, A, B and C.

<b>Characteristics</b>	<b>A</b>	<b>B</b>	<b>C</b>
Can make its own food	Yes	No	No
Has scales	No	Yes	No
Lives in water only	No	Yes	No
Has spores	Yes	No	Yes

Which of the following groups do A, B and C belong to respectively?

	<b>A</b>	<b>B</b>	<b>C</b>
(1)	plant	reptile	plant
(2)	plant	fish	fungi
(3)	fungi	reptile	plant
(4)	fungi	fish	fungi

3. Which of the following are functions of the skeletal system in a human body?

- A: Give the body shape
- B: Support the human body
- C: Protect the organs in the body
- D: Transport blood around the body

- (1) A and D only
- (2) B and C only
- (3) A, B and C only
- (4) A, B, C and D

4. During recess, Jane ate 100 g of food. The diagram below shows the amount of undigested food when it exits organs, A, B, and C, of the digestive system.

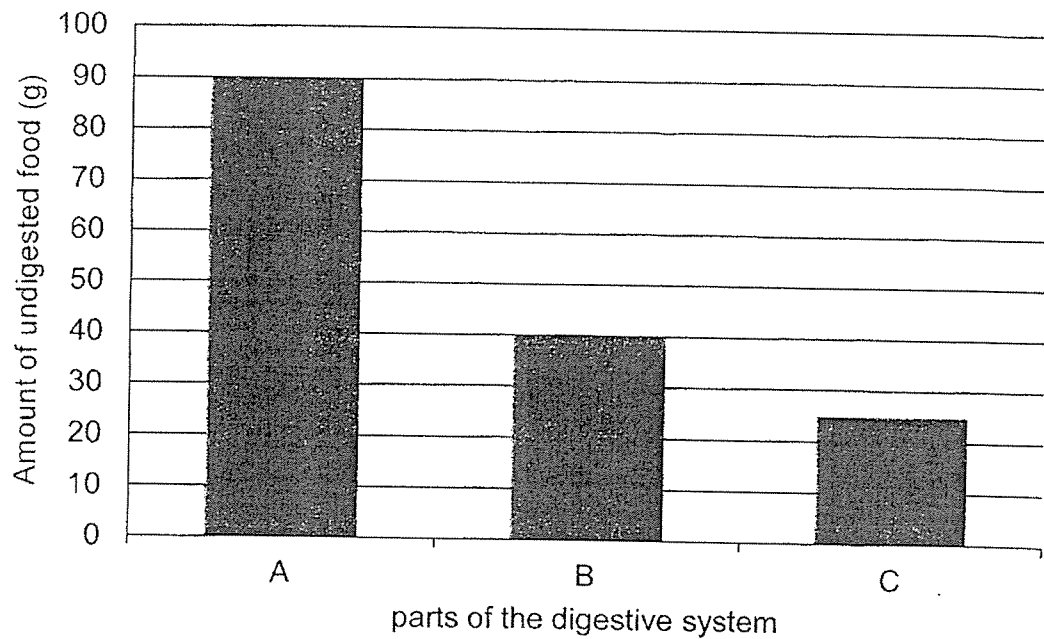

Which parts of the digestive system do A, B and C represent?

	A	B	C
(1)	small intestine	mouth	stomach
(2)	small intestine	stomach	mouth
(3)	mouth	stomach	small intestine
(4)	stomach	mouth	small intestine

5. Which of the following functions are correctly matched to the plant parts?

	Roots	Stem
(1)	Trap sunlight to make food	Support the plant to receive sunlight
(2)	Absorb water for the plant	Support the plant to receive sunlight
(3)	Absorb water for the plant	Hold the plant firmly to the ground
(4)	Hold the plant firmly to the ground	Trap sunlight to make food

6. Andrea prepared two experiments as shown below. She filled 2 identical beakers, M and N, with the same amount of water and put 2 similar plants in them. She then removed the roots of the plant in Beaker M. The layer of oil prevents water from escaping into the surrounding air.

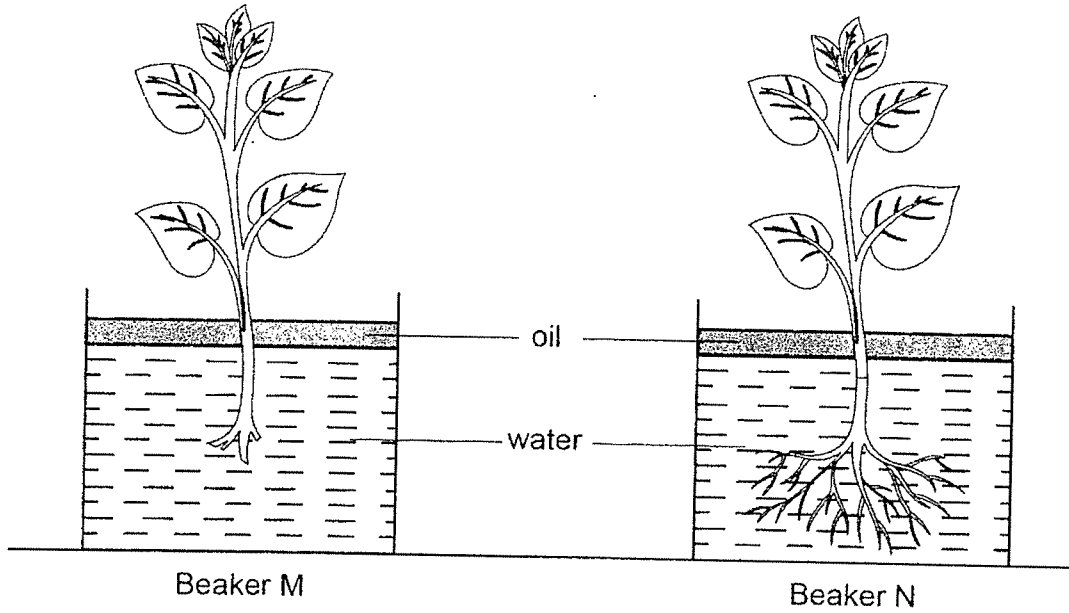

She recorded the amount of water in each beaker at the end of 5 days.

	Beaker M	Beaker N
Volume of water at first (ml)	300	300
Volume of water after 5 days (ml)	?	?

Which one of the following best represents the volume of water in beakers, M and N at the end of 5 days?

	Beaker M	Beaker N
(1)	300	300
(2)	310	300
(3)	290	300
(4)	290	250

7. The diagram below shows a hammer hitting a nail.

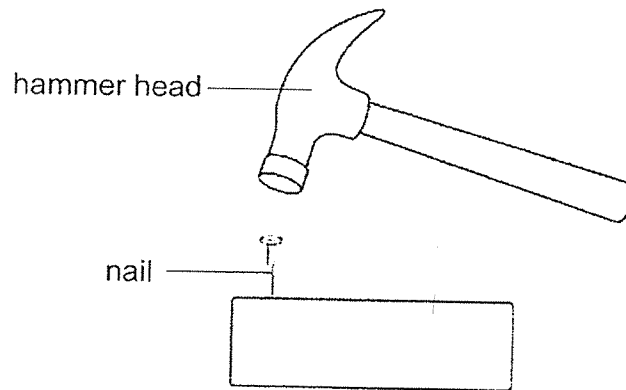

Metal is used to make the hammer head because metal is \_\_\_\_\_.

- (1) strong
- (2) flexible
- (3) waterproof
- (4) able to sink in water



8. Strips of material A and material B were hung on a hook as shown below.

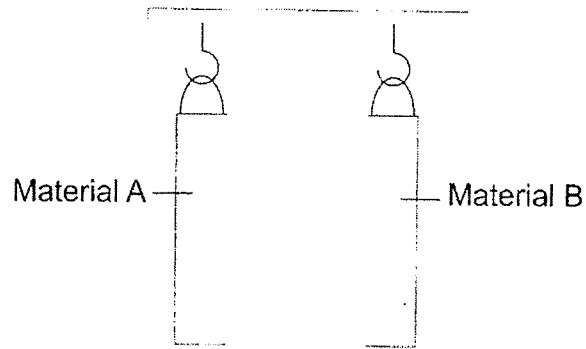

Two identical boxes were then hung onto the strips. Carrie observed the outcome of the experiment as shown below.

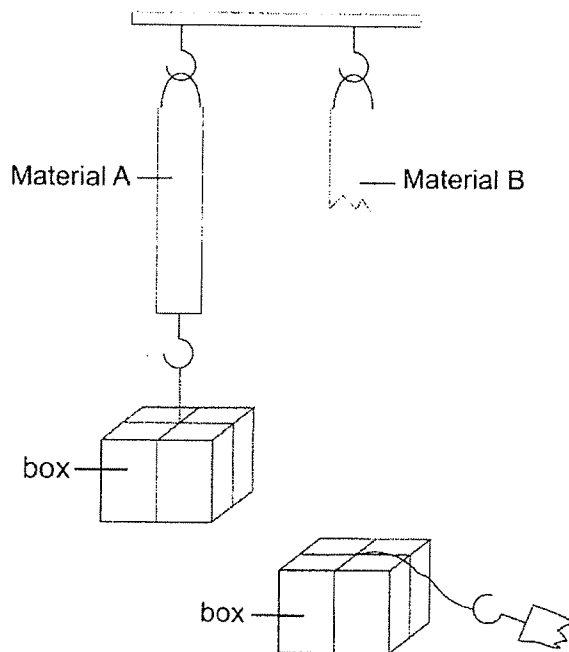

Which one of the following conclusion could be made from the above experiment?

- (1) Material B is heavier than Material A.
- (2) Material A is stronger than Material B.
- (3) Material B is more flexible than Material A.
- (4) The box hung on Material A is lighter than the box hung on Material B.

9. A bar magnet was suspended freely from a retort stand as shown below.

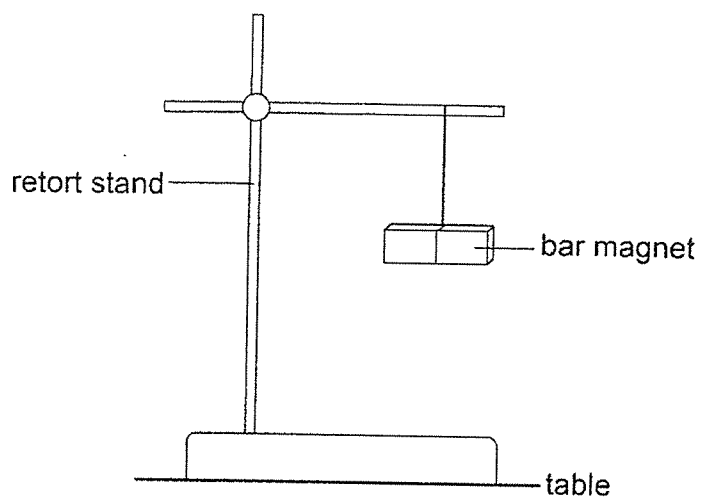

The bar magnet would come to rest in the \_\_\_\_\_ direction.

- (1) East-West
- (2) North-East
- (3) South-West
- (4) North-South

10. Jessica had four different magnets, A, B, C and D. She placed a steel paper clip at Position M. She moved each magnet towards the paper clip until it attracted the paper clip and measured the distance,  $P$ , between the paper clip and the magnet.

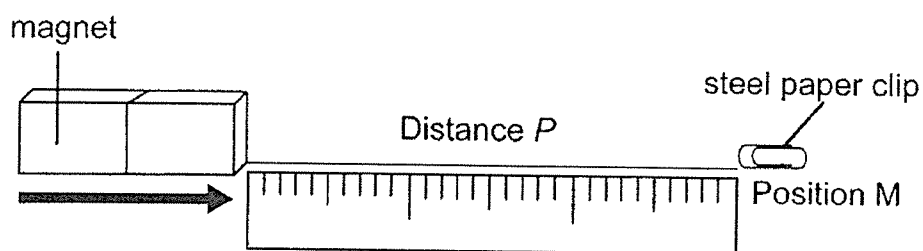

She recorded her results in the table shown below.



Magnet	Distance $P$ (cm)
A	5
B	3
C	8
D	6

Based on the results above, arrange the magnets in order of their magnetic strength from the strongest to the weakest.

- (1) B, A, D, C
- (2) B, D, A, C
- (3) C, A, D, B
- (4) C, D, A, B

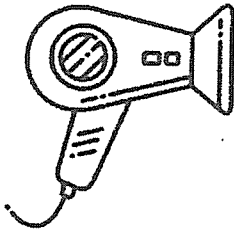
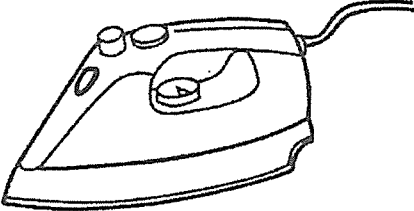
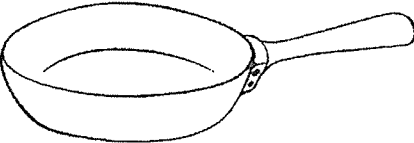

11. The following objects are classified based on whether they are sources of heat.

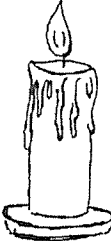
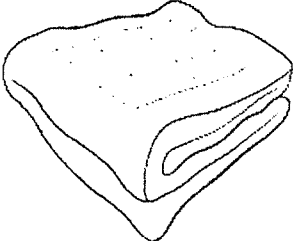
Sources of heat	Not sources of heat
 hairdryer	 iron
 frying pan	 jacket
 burning candle	 blanket

Which of the following objects are classified wrongly?

- (1) hairdryer and iron only
- (2) frying pan and iron only
- (3) frying pan and jacket only
- (4) hairdryer and blanket only

12. John stuck four identical drops of wax, A, B, C and D, to an iron rod. He then heated the iron rod as shown in the diagram below.

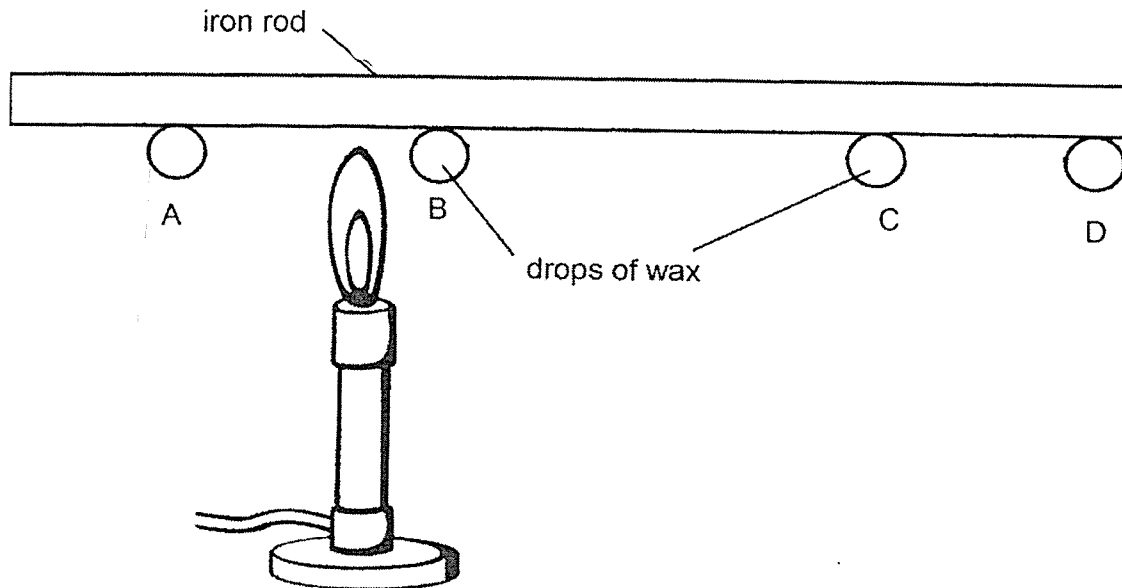

Which one of the following shows John's observation?

- (1) The drops of wax changed from liquid to gas.
- (2) A, B, C and D fell off the iron rod at the same time.
- (3) B is the first to fall off the iron rod while D is the last to fall off the iron rod.
- (4) D is the first to fall off the iron rod while A is the last to fall off the iron rod.

13. Look at the picture below.

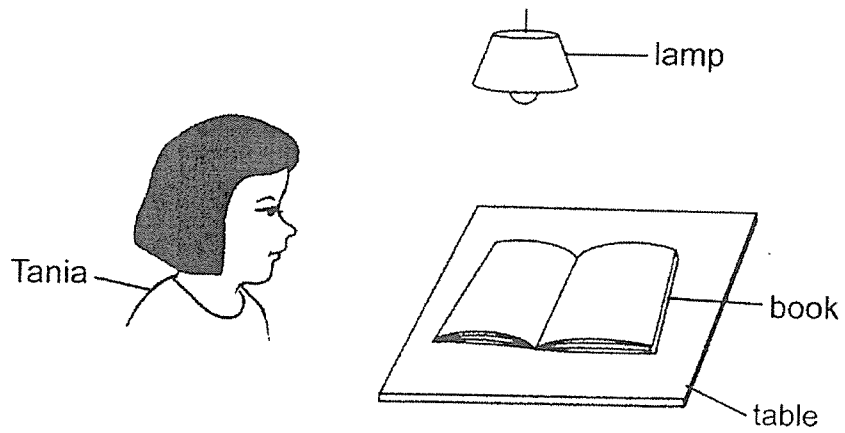

Which one of the following shows the path of light which enables Tania to see the book on the table?

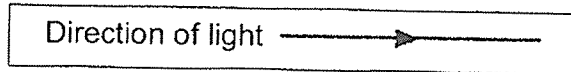

(1)

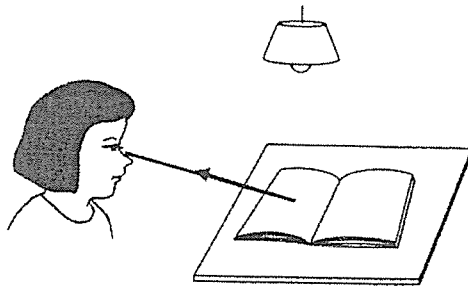

(2)

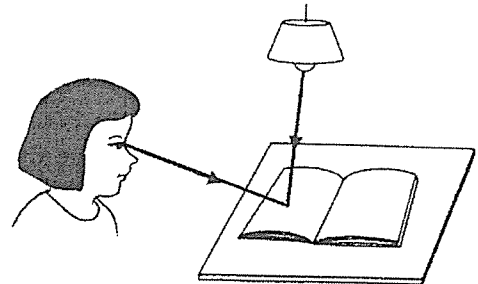

(3)

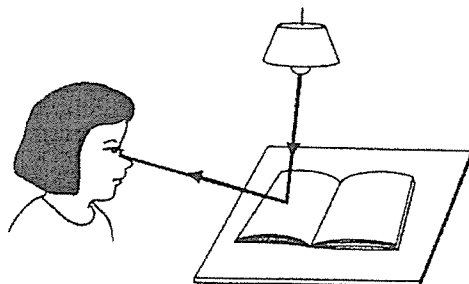

(4)

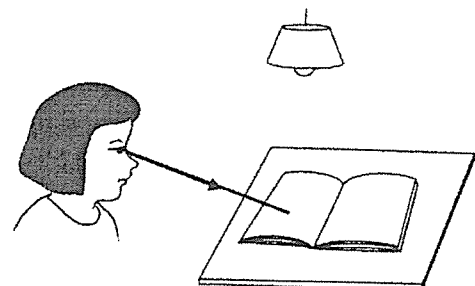

14. An experiment was conducted to find out the amount of light that can pass through different materials of the same size and thickness at the same time. They were placed at positions, A, B and C, in a dark room as shown below. The greater the amount of light detected by the light sensor, the greater the reading on the data logger.

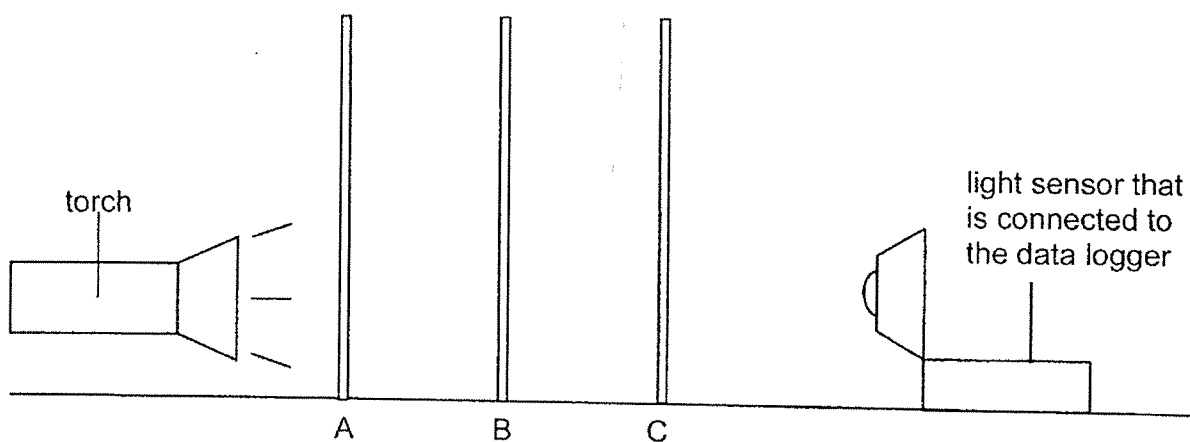

Which one of the following correctly shows which materials are at positions A, B and C, and the reading on the datalogger as shown above?

	<b>A</b>	<b>B</b>	<b>C</b>	<b>Reading on data logger (units)</b>
(1)	clear glass	clear plastic sheet	tracing paper	0
(2)	tracing paper	cardboard sheet	clear glass	0
(3)	tracing paper	clear glass	cardboard sheet	30
(4)	clear plastic sheet	tracing paper	cardboard sheet	120

**Section B: Open-ended Questions (3 x 4 = 12 marks)**

15. Study the flowchart below.

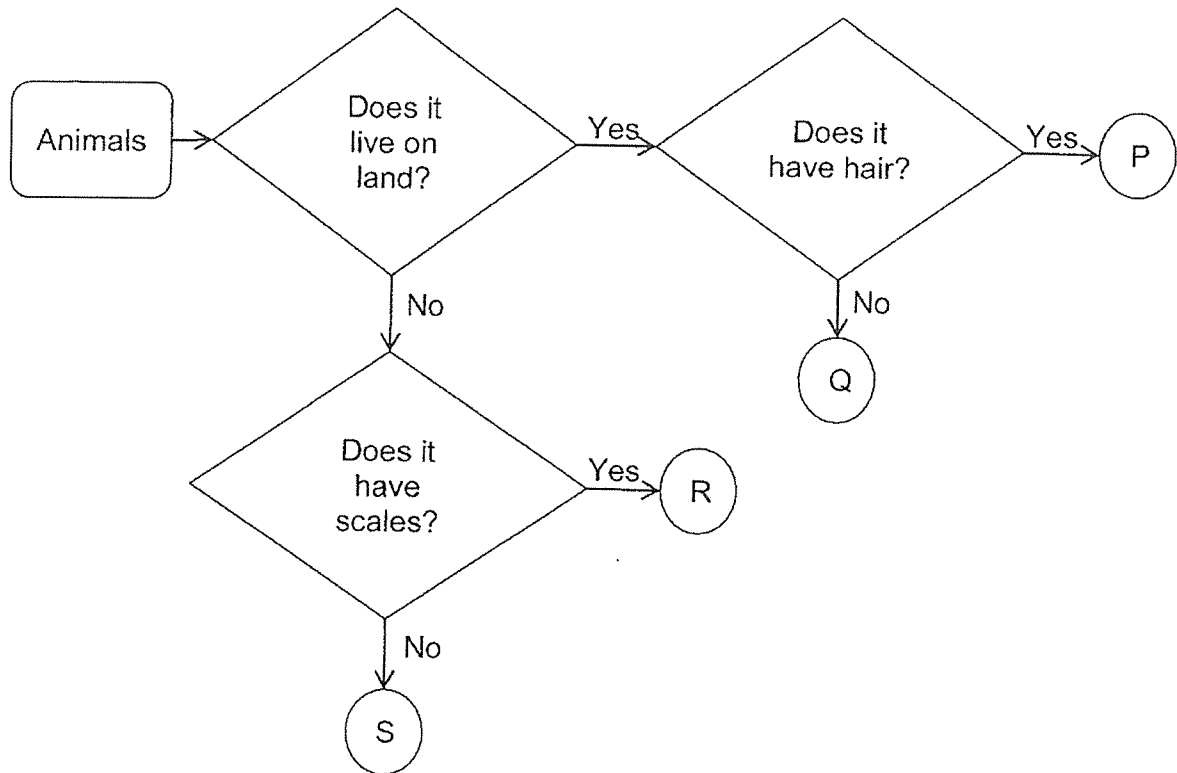

(a) Based on the information in the above flowchart only, state one similarity between P and Q. (1m)

---



---

(b) Based on the information in the above flowchart only, state one difference between P and S. (1m)

---

---

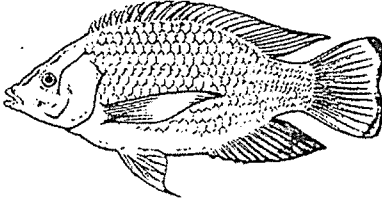
- (c) Based on the flowchart in the previous page, which letter, P, Q, R or S, best represents the following animals? (2m)

Animal	Letter (P, Q, R or S)
 <p data-bbox="611 678 707 712">Tilapia</p>	<p data-bbox="1082 701 1273 723">_____</p>
 <p data-bbox="611 969 699 1003">Parrot</p>	<p data-bbox="1106 981 1281 1003">_____</p>

16. Four similar ice cubes are placed in four sealed containers, W, X, Y and Z. The containers are made of different materials of equal thickness and identical size. The graph below shows the time taken for the ice in each container to melt completely.

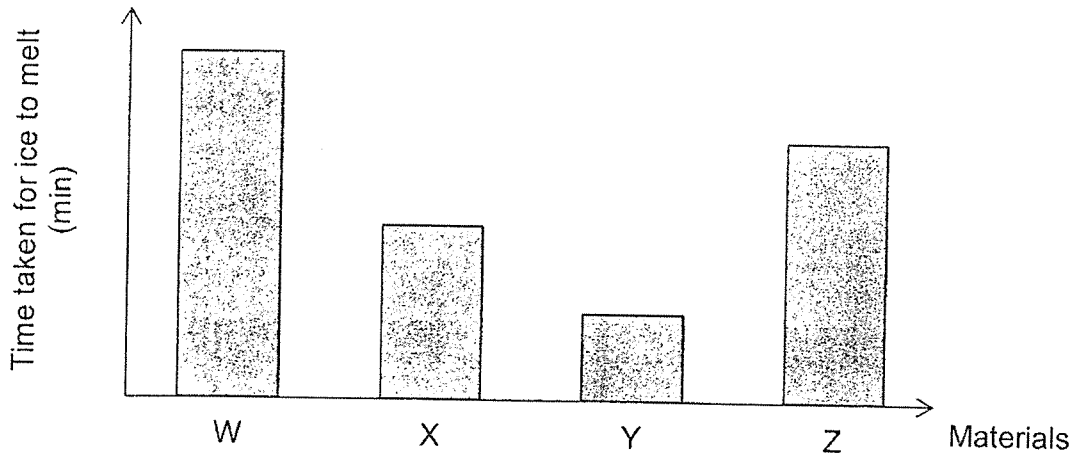

- (a) Based on the information above, which material, W, X, Y and Z, would most likely be metal? Explain your answer. (2m)

---

---

- (b) Kenny is going for a picnic at the park and would be bringing ice cream. Based on the information given above, which material, W, X, Y or Z, should he use if he wants to make sure that the ice cream is still cold when he arrives at the park? Explain your answer. (2m)

---

---

---

17. Adriel was at the park at night. He was able to see the moon, a dustbin, a street lamp and a tree.

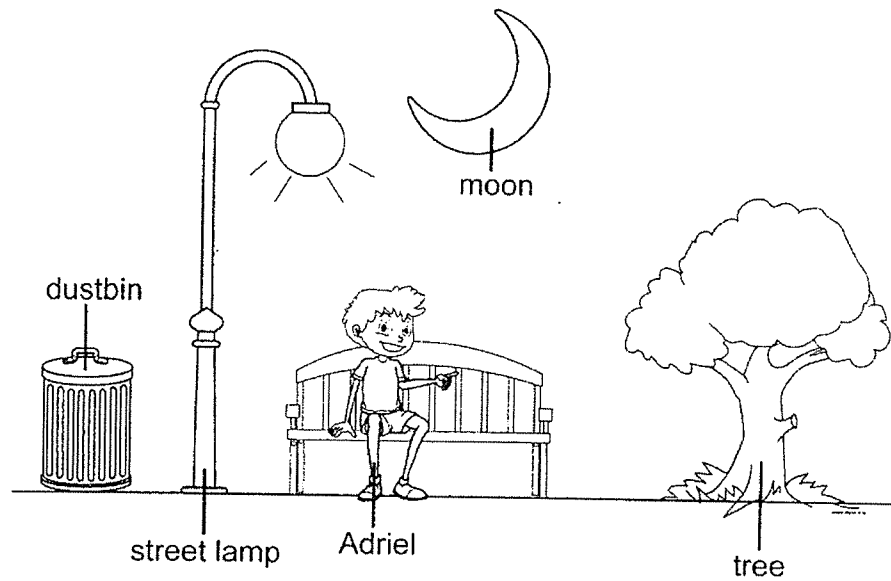

- (a) Based on the diagram above, identify the source of light. (1m)

---

- (b) Explain how Adriel was able to see the tree at night. (1m)

---

---



- (c) Adriel conducted an experiment to find out the amount of light that can pass through materials, A, B and C. The greater the amount of light detected by the light sensor, the greater the reading on the data logger.

He recorded his findings in the table below.

Materials	Reading on data logger (units)
A	370
B	0
C	100

- (i) Put a tick (✓) to show the changed variable in the experiment above. (1m)

Variable	Changed variable
Types of material	
Types of light source	
Thickness of material	

- (ii) Adriel wanted to set up an aquarium for his fish. He wanted a material that allows him to see the fish clearly.

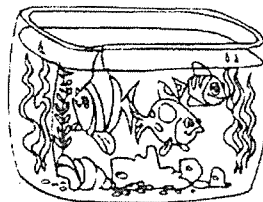

Based on the Adriel's finding, which of the following materials, A, B or C, is the most suitable material for the tank? Give a reason for your answer. (1m)

---



---



---

End of Paper  
Please check your answer.

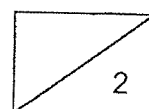



SCHOOL : RED SWASTIKA PRIMARY SCHOOL

LEVEL : PRIMARY 4

SUBJECT : SCIENCE

TERM : TEST 2 2023

---

Q1	Q2	Q3	Q4	Q5	Q6	Q7	Q8	Q9	Q10
3	2	3	3	2	4	1	2	4	4

Q11	Q12	Q13	Q14
2	3	3	3

Q15)	a) Both P and Q live on land. b) P lives on land while S does not. c) B Q
Q16)	a) Material Y. Y is the best conductor of heat so it took the shortest time of melt the ice. b) Material W is the poorest conductor of heat as the ice in W took the longest time to melt.
Q17)	a) The street lamp is the source of light. b) The light from the street lamp is reflected of the tree and into Adriel's eye. c) i)Types of material ii)Material A. It allows the most light to pass through.



