



ST. HILDA'S PRIMARY SCHOOL
END-OF-YEAR EXAMINATION, 2023

PRIMARY 4

SCIENCE

Booklet A

Name : _____ () Class: Primary 4 / _____

Date: 20 October 2023

Total Time for Booklets A and B: 1 hour 45 minutes

Additional Materials: Optical Answer Sheet (OAS)

INSTRUCTIONS TO CANDIDATES

1. Write your name, index number and class above.
2. Do not turn over this page until you are told to do so.
3. Follow all instructions carefully.
4. Answer all questions.
5. Use a 2B pencil to shade your answers on the Optical Answer Sheet (OAS).

This booklet consists of 21 printed pages.

For each question from 1 to 28, four options are given. One of them is the correct answer. Make your choice (1, 2, 3 or 4) and shade your answer on the Optical Answer Sheet.

(56 marks)

1 Study the diagram below.

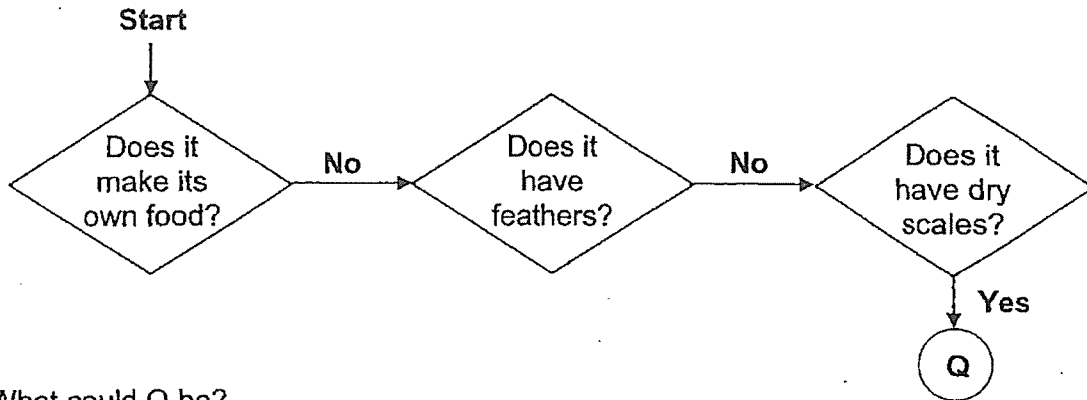

What could Q be?

- (1) bird
- (2) reptile
- (3) insect
- (4) amphibian

2 The arrows () below show the direction of movement of a substance in plants.

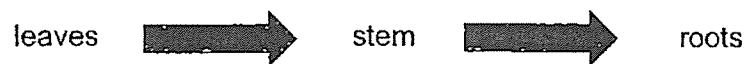

What is this substance?

- (1) light
- (2) food
- (3) water
- (4) minerals

3 Which organ system is shown in the diagram?

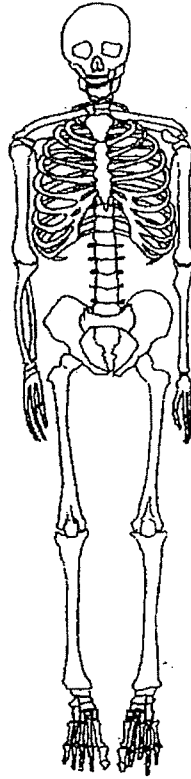

- (1) skeletal system
- (2) muscular system
- (3) circulatory system
- (4) respiratory system

4 A, B, C and D are the various stages in the life cycle of a mosquito.

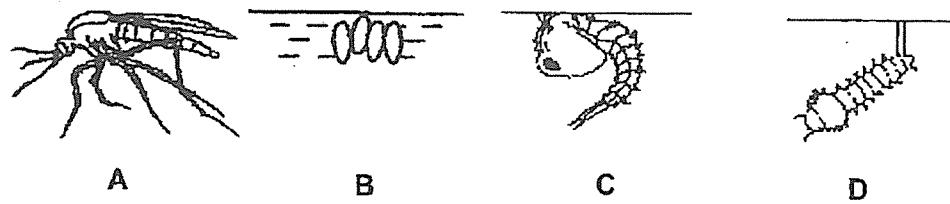

Which of the following correctly shows the life cycle of a mosquito?

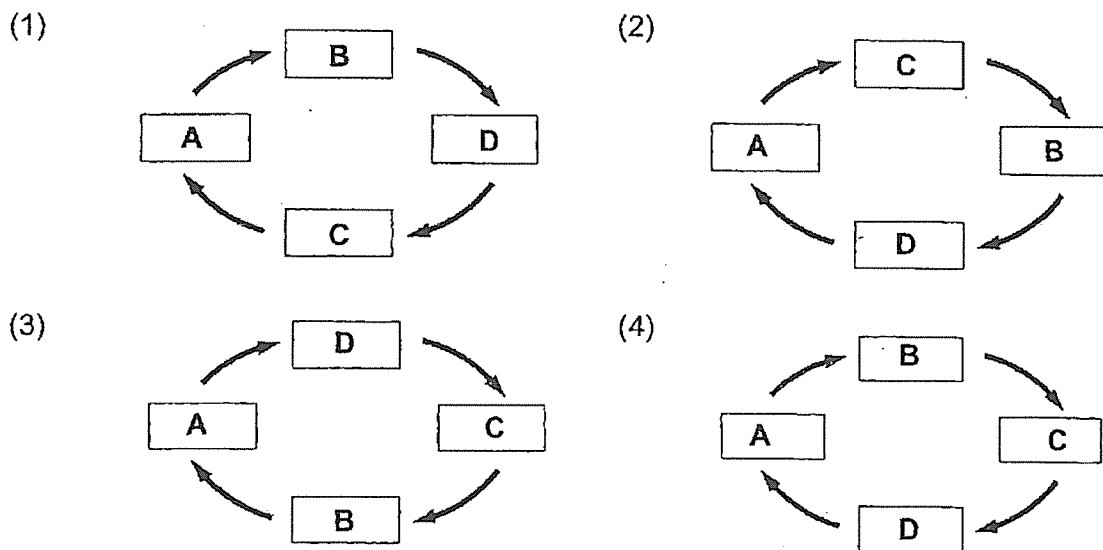

5 Which of the following is **not** correct for both the mealworm beetle and cockroach?

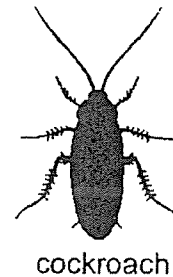
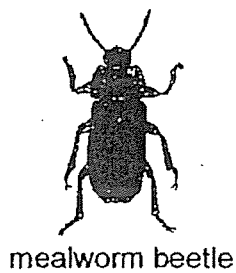

- (1) Both lay eggs.
- (2) Both their adults have six legs.
- (3) Both their young and adult live on land.
- (4) Both have young that looks like the adult.

6 Study the flowchart below.

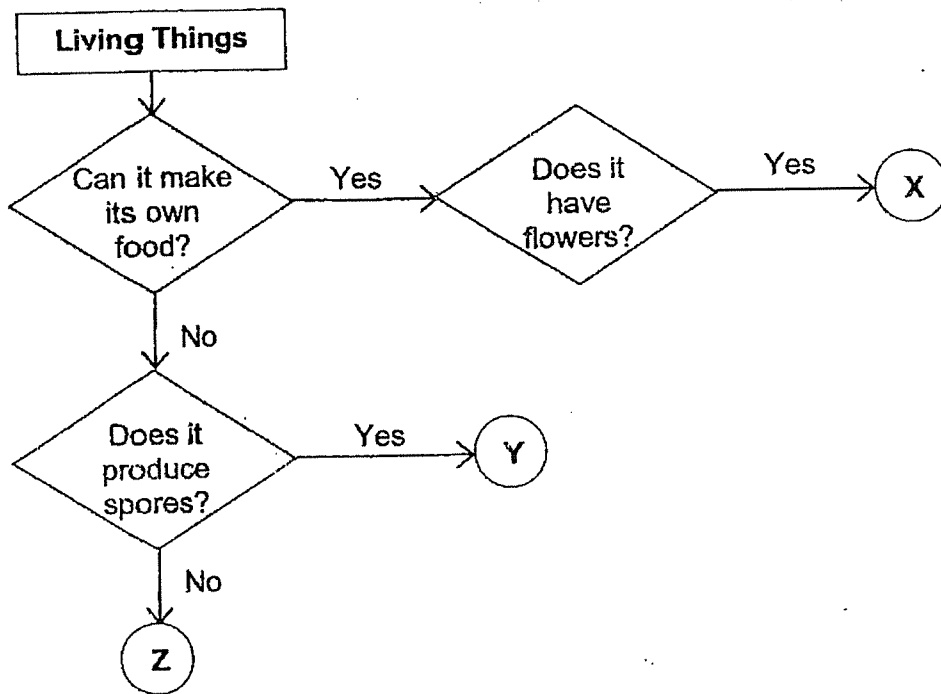

What could X, Y and Z be?

	X	Y	Z
(1)	Moss	Mushroom	Bacteria
(2)	Moss	Bacteria	Rose plant
(3)	Rose plant	Moss	Mushroom
(4)	Rose plant	Mushroom	Bacteria

7 The diagram below shows parts of a plant.

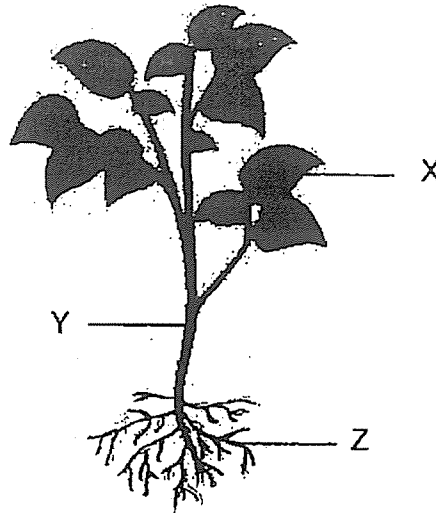

Which of the following statements is **not** correct?

- (1) Part Z absorbs water only.
- (2) Part X traps light to make food.
- (3) Part Z anchors the plant firmly to the ground.
- (4) Part Y supports the plant by holding it upright.

- 8 Tommy saw a plant that had been struck by lightning during a recent thunderstorm as shown below.

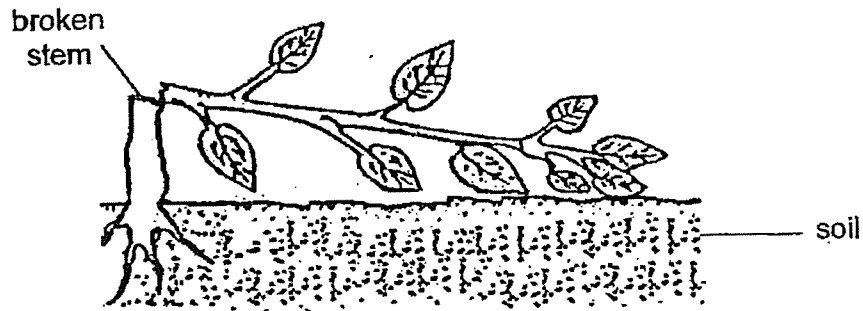

Based on the observation above, the stem will not be able to _____

- (1) make food for the plant
 - (2) trap sunlight for the plant
 - (3) anchor the plant to the soil
 - (4) hold the leaves and branches upright
- 9 Nadia wrote some statements about the functions of the different human systems.
- A The digestive system absorbs digested food into the bloodstream.
 - B The respiratory system takes in air and gives out air.
 - C The skeletal system protects the heart only.

Which of her statement(s) is/are correct?

- (1) A only
- (2) A and B only
- (3) B and C only
- (4) A, B and C

10 The diagram below shows the human digestive system.

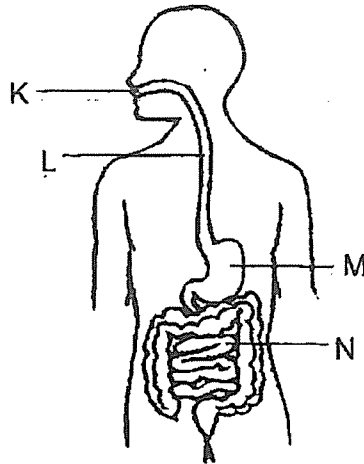

Which of the following shows the changes to the amount of undigested food as it leaves organs K, L, M and N?

	K	L	M	N
(1)	increase	increase	increase	decrease
(2)	decrease	increase	decrease	increase
(3)	decrease	no change	decrease	decrease
(4)	no change	no change	increase	decrease

11 The diagram below shows the development of a plant.

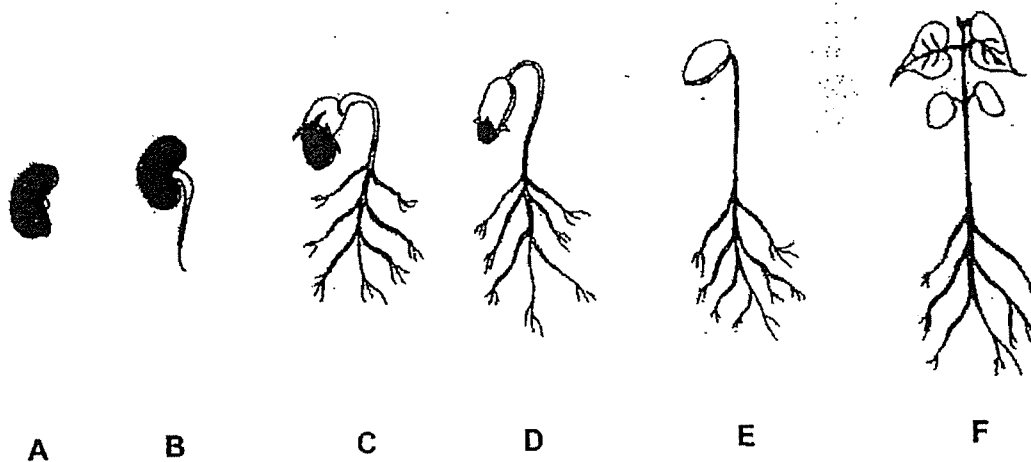

Based on the above diagram, which of the following statements is correct?

- (1) The roots of plant will grow after the shoot appears.
- (2) At C, the seedling gets its food from the seed coat.
- (3) At D, the seedling gets its food from the seed leaves.
- (4) At E, the seedling can make its own food.

12 James wanted to compare the life cycle of a frog and a grasshopper.

He wrote the similarities of the two life cycles in his notebook.

- A: Both have the egg stage.
- B: Both have the pupa stage.
- C: Both the adults lay eggs in the water.
- D: Both have three stages in their life cycles.

Which of the following statements are correct?

- (1) A and D only
- (2) B and C only
- (3) C and D only
- (4) A, B and C only

13 The diagram below shows a car.

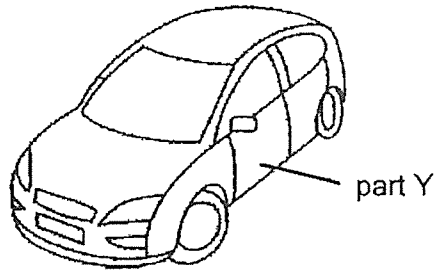

Metal is used to make part Y of the car because metal _____.

- (1) is shiny
- (2) is strong
- (3) can reflect light well
- (4) can conduct heat well

14 Ronald places a metal spoon in a cup of hot coffee.

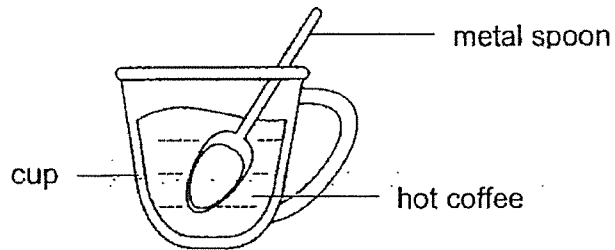

The metal spoon becomes hotter after a while.

Which of the following statements explains this?

- (1) The cup loses heat to the hot coffee.
- (2) The metal spoon loses heat to the hot coffee.
- (3) The hot coffee gains heat from the metal spoon.
- (4) The metal spoon gains heat from the hot coffee.

15 Matter is anything that has mass and occupies space.

Which one of the following is **not** matter?

- (1) oxygen
- (2) stone
- (3) heat
- (4) milk

16 Which one of the following will **not** be attracted by a magnet?

- (1) Iron rod
- (2) Steel rod
- (3) Copper rod
- (4) Cobalt rod

17 In which of the following arrangements will the two magnets move towards each other?

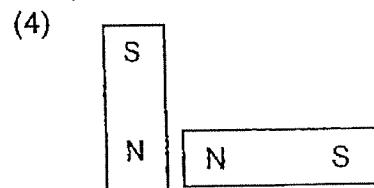
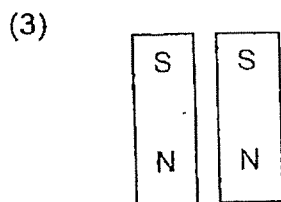
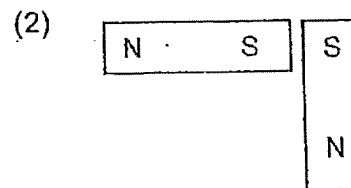
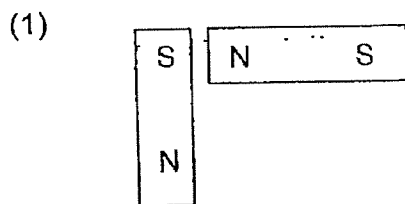

- 18 The set-up below shows light shining on a metal cylinder.

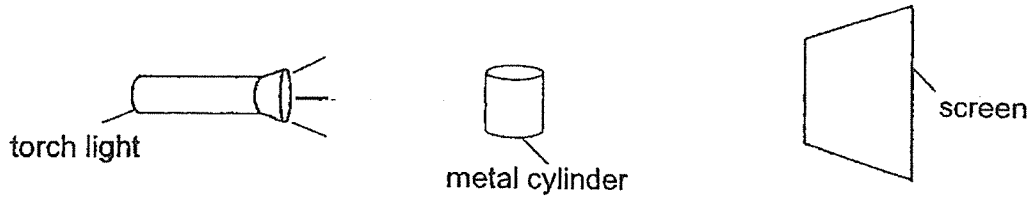

Which of the following observations would likely be seen on the screen?

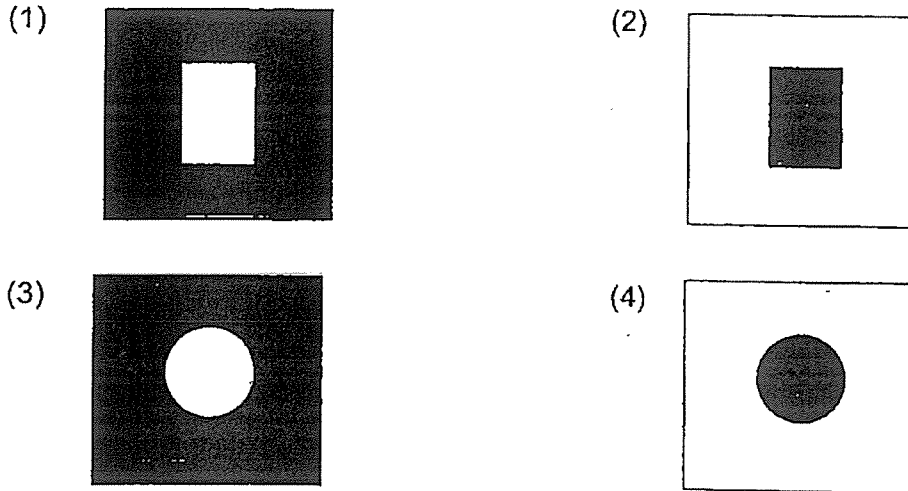

- 19 Four bars, W, X, Y and Z were hung from a rod. The bars moved in different directions as shown.

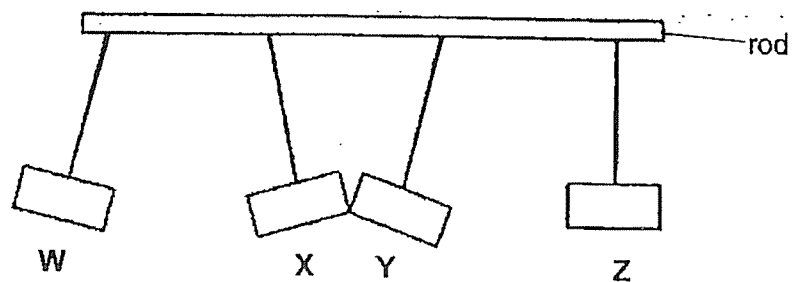

If only two of the bars are magnets, which bars, W, X, Y or Z are **most likely** to be magnets?

- (1) Y and Z
- (2) X and Y
- (3) W and X
- (4) W and Y

- 20 Fatimah sets up an experiment below to find out how the number of batteries and the number of coils around the iron nail affects the strength of the electromagnet.

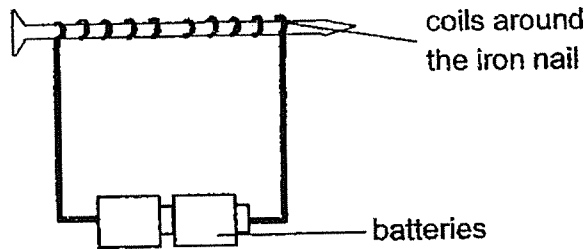

The table below shows four different set-ups.

Set-up	Number of batteries	Number of coils around the iron nail
A	3	10
B	3	20
C	2	10
D	2	20

Which two set-ups should she use to conduct a fair test for each of the aim?

Aim: To find out how		
	the number of batteries affects the strength of the electromagnet	the number of coils around the nail affects the strength of the electromagnet
(1)	A and B	A and D
(2)	A and D	A and B
(3)	C and D	B and C
(4)	B and D	C and D

- 21 The diagram below shows a syringe which was fitted to a bottle with a fixed capacity of 250 cm^3 . The bottle was filled with 50 cm^3 of water.

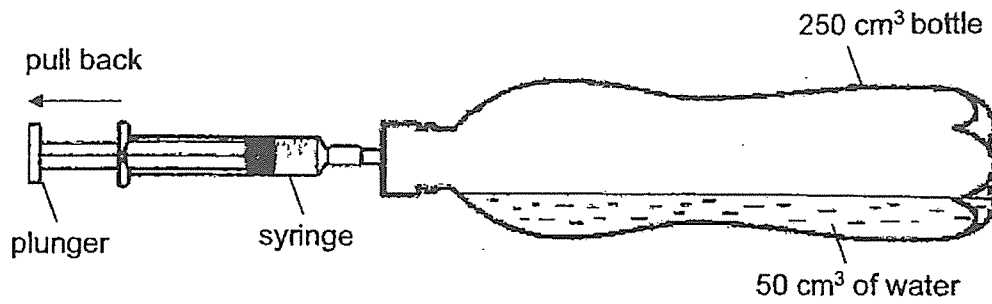

When the plunger was pulled back completely, 10 cm^3 of air would be drawn out of the bottle.

Which of the following correctly shows the final volume of water and air left in the bottle?

	Final volume left in bottle (cm^3)	
	water	air
(1)	250	250
(2)	250	240
(3)	50	200
(4)	50	190

- 22 Axl dropped stone A into a displacement can filled with water. Some water flowed out of the displacement can and dripped into measuring cylinder Y as shown in the diagram below.

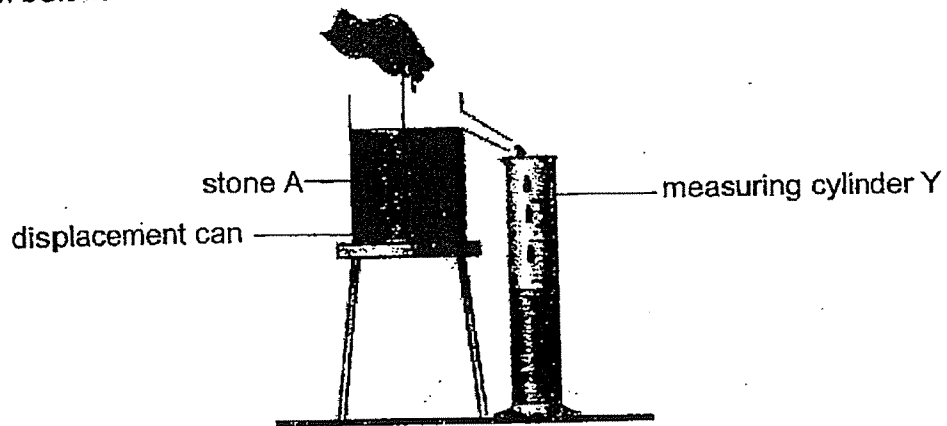

Which of the following statements can be concluded from the above observation?

- (1) Stone A has mass.
- (2) Stone A occupies space.
- (3) Stone A has a definite shape.
- (4) Stone A cannot be compressed.

23 When Dino was standing behind the wall as shown, he could not see his father.

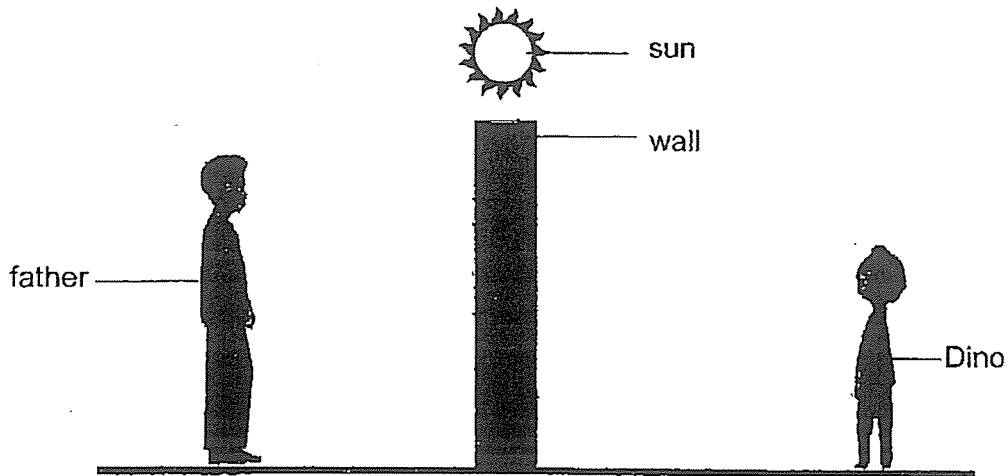

Which of the following was the reason why Dino could not see his father?

- (1) The wall reflected the light.
- (2) Dino's father reflected the light.
- (3) The wall did not allow light to pass through.
- (4) Dino's father did not allow light to pass through.

24 Jessica set up the following experiment in a dark room. She used a light sensor to measure the amount of light on the screen. She changed the position of one of the items in the set-up and recorded her observations for each position as shown in the table below.

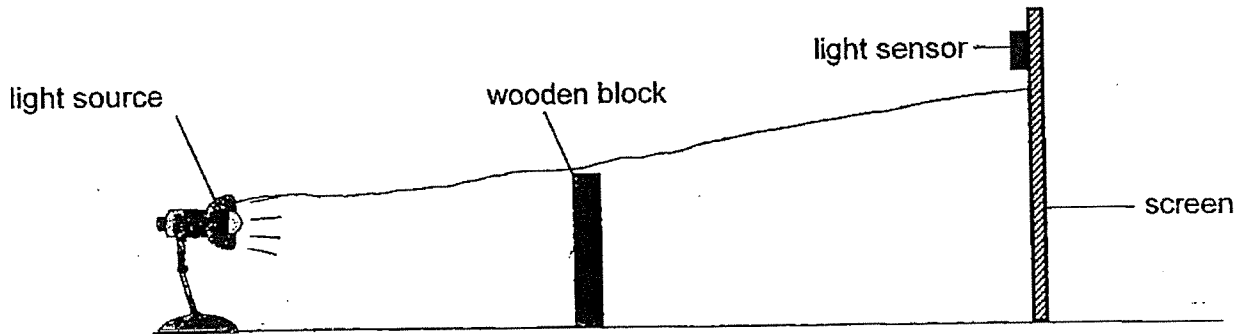

Position	Light sensor reading (units)	Height of shadow (cm)
1	250	10
2	200	17
3	180	19
4	120	27

What change did Jessica make?

- (1) The screen was moved towards the light source.
- (2) The screen was moved away from the wooden block.
- (3) The wooden block was moved towards the light source.
- (4) The light source was moved away from the wooden block.

- 25 Mr Lee sells fish in a wet market. He wears an apron when he is working to keep his clothes dry.

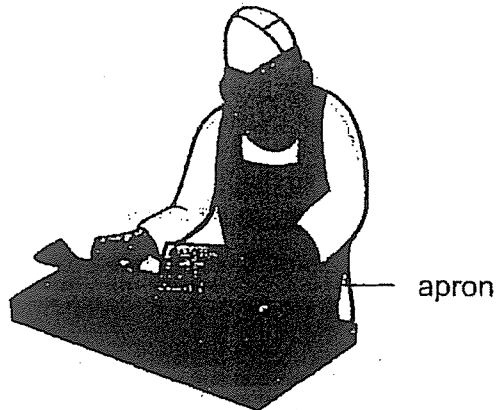

The table below shows the properties of four materials, W, X, Y and Z.

Materials	Properties			
	Does it absorb water?	Does it allow light to pass through?	Does it break easily when dropped?	Does it bend easily?
W	Yes	No	Yes	Yes
X	Yes	No	No	No
Y	No	Yes	Yes	No
Z	No	No	No	Yes

Which of the following materials, W, X, Y or Z, should the apron be made of?

- (1) W
- (2) X
- (3) Y
- (4) Z

26 Thavish carried out an experiment to find out the flexibility of materials S and T which are of the same length and thickness.

Which of the following correctly shows that material S is less flexible than material T?

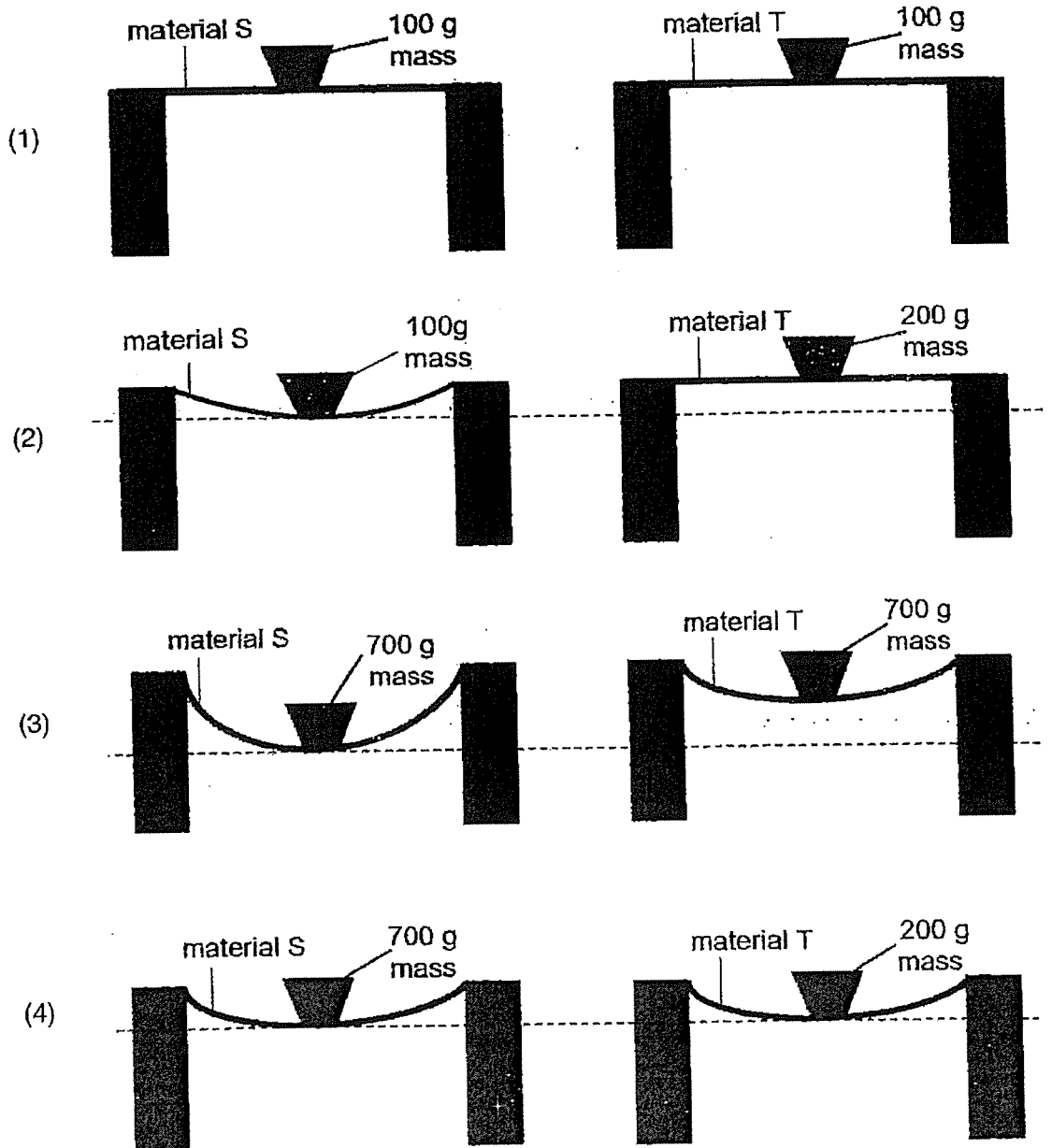

- 27 Shu Ling puts a dented ping pong ball into a basin of hot water.

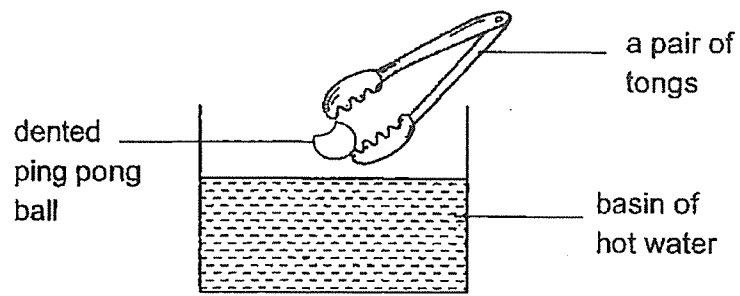

What will she observe after the dented ping pong ball is pushed down with a pair of tongs into the basin of hot water for a few minutes?

- A The shape of ping pong ball changes.
 - B The water level in the basin increases.
 - C The volume of ping pong ball increases.
 - D The water level in the basin decreases.
- (1) A and C only
- (2) A and D only
- (3) B and C only
- (4) A, B and C only

- 28 Shatiqah poured some water into two pots, X and Y. The pots were of the same size but made of different materials. Pot X contained 600 ml of water and pot Y contained 300 ml of water. Both pots were heated over a flame until the water boiled.

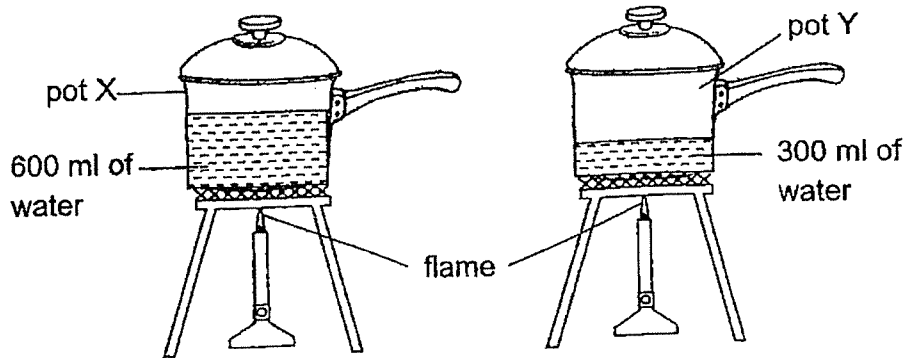

Shatiqah observed that the water in both pots took the same amount of time to reach 100°C .

Which of the statements below could be possible explanations for her observation?

- A The flame used for pot Y was stronger.
 - B Pot X is made of a material that conducts heat faster.
 - C The temperature of the water in pot X was higher at the start of the experiment.
- (1) A and B only
(2) A and C only
(3) B and C only
(4) A, B and C

End of Booklet A

(Go on to Booklet B)



ST. HILDA'S PRIMARY SCHOOL
END-OF-YEAR EXAMINATION, 2023
PRIMARY 4
SCIENCE

Booklet B

Name : _____ () Class: Primary 4 / _____

Date: 20 October 2023

Total Time for Booklets A and B: 1 hour 45 minutes

Parent's Signature:

INSTRUCTIONS TO CANDIDATES

1. Write your name, index number and class above.
2. Do not turn over this page until you are told to do so.
3. Follow all instructions carefully.
4. Answer all questions.
5. Use a pencil or a dark blue or black ballpoint pen to write your answers in the space provided for each question.
6. Do not use correction fluid/tape or highlighters.

Booklet	Maximum Marks	Marks Obtained
A	56	
B	44	
Total	100	

This booklet consists of 18 printed pages.

For questions 29 to 41, write your answers in this booklet.
 The number of marks available is shown in brackets [] at the end of each question or part question.

(44 marks)

29 The diagram below shows the human digestive system.

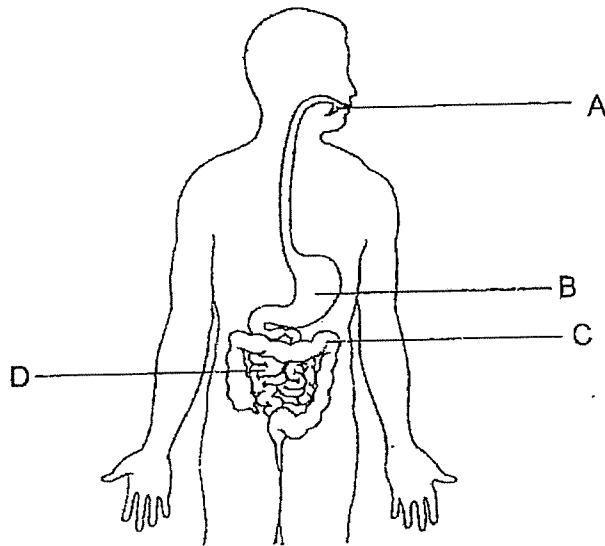

Identify the part A, B, C or D where

- (a) digested food is absorbed into the blood: Part _____ [1]
 (b) no digestive juice is produced: Part _____ [1]

30(a) The diagram below shows the stages in the life cycle of a cockroach.

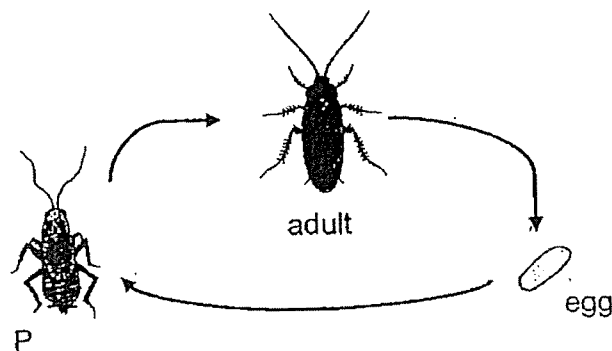

- (i) Name stage P: _____ [1]
 (ii) Name one other animal that has a similar life cycle as a cockroach. [1]

(Continues on next page)

SCORE	4
-------	---

Study the life cycle of a butterfly shown below.

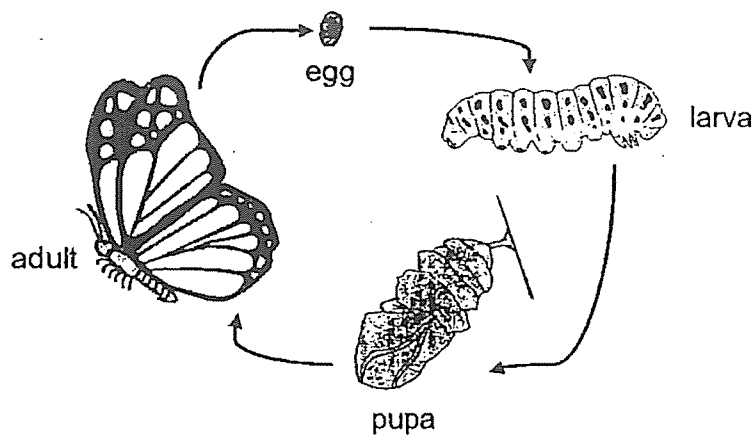

The graph below shows the amount of food eaten by a butterfly during the different stages of its life cycle which are represented by PQ, QR, RS and ST.

Amount of food eaten each day (units)

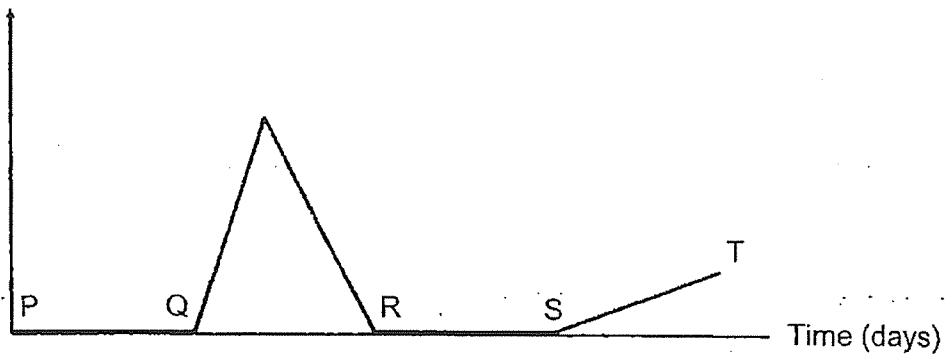

- (b) If PQ represents the egg stage in the life cycle of a butterfly, state which part of the graph, QR, RS or ST represents the pupa stage in the life cycle of a butterfly. Explain your answer. [2]

SCORE	2
-------	---

31 Study the flowchart carefully.

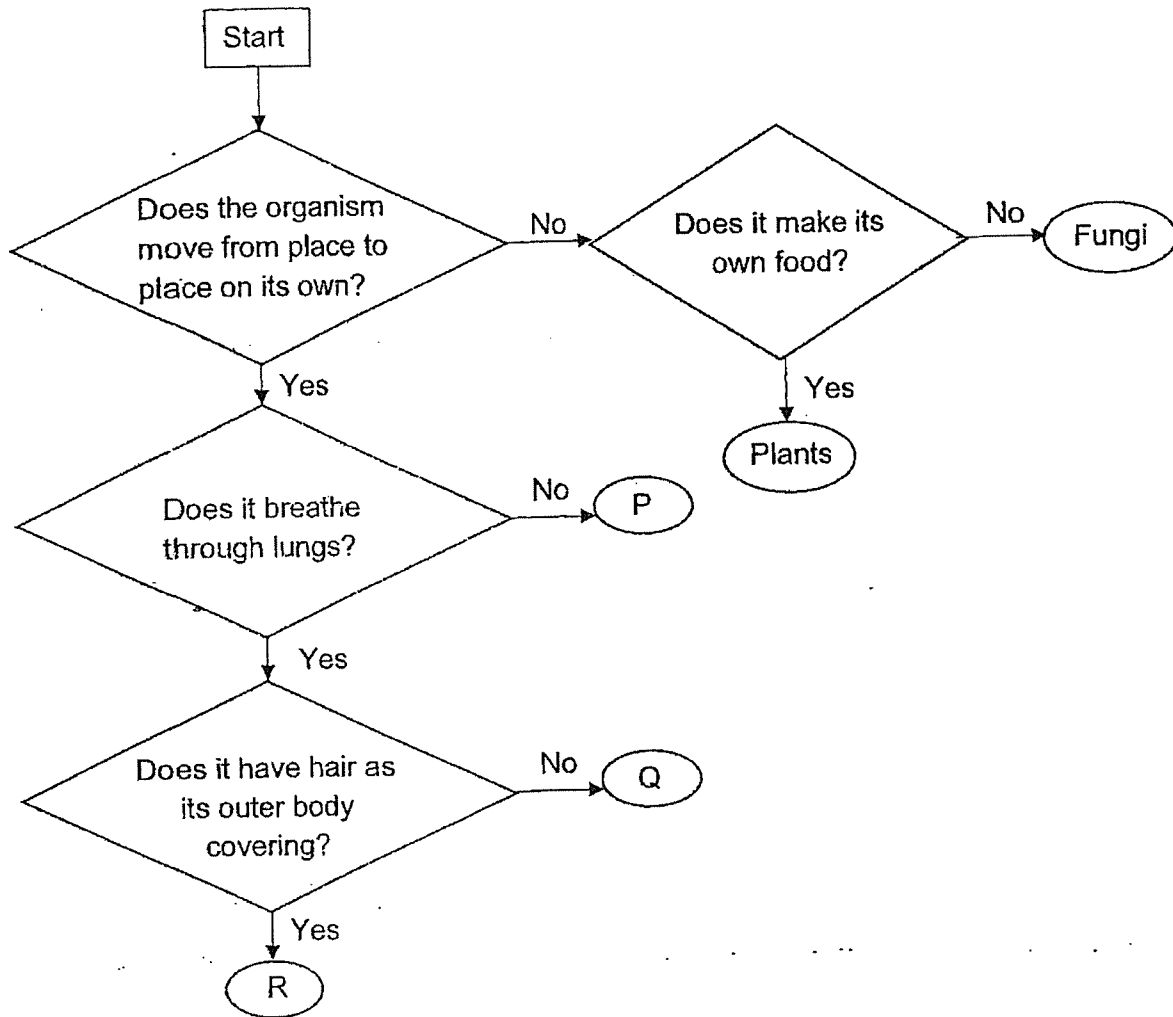

(a) Based on the flowchart above, which group of living things can organism R be classified under? [1]

(b) Based on the flowchart above, state a difference between organism P and Q. [1]

(c) Can organism P be represented by a fish? Explain your answer. [1]

(d) Name a type of fungus. State how it reproduces. [1]

SCORE	4
-------	---

- 32 Mr Pang set up an experiment to find out if the number of leaves affects the volume of water absorbed by the roots. Two similar plants with the same amount of roots were given 500 ml of water and were left beside the window for a week. Same amount of oil was poured into the containers. The plant in set-up X had some leaves removed.

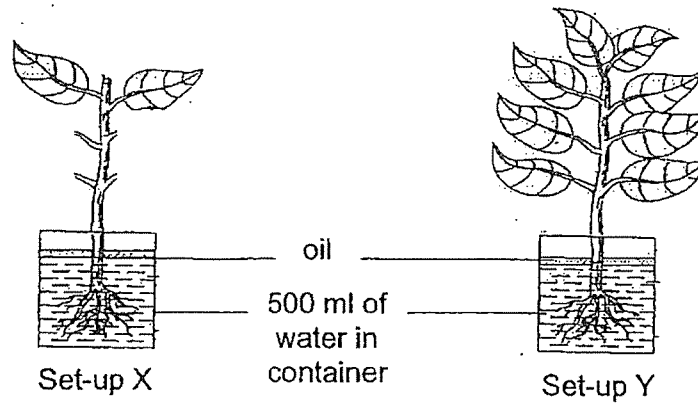

He recorded the volume of water left in the containers in the graph below.

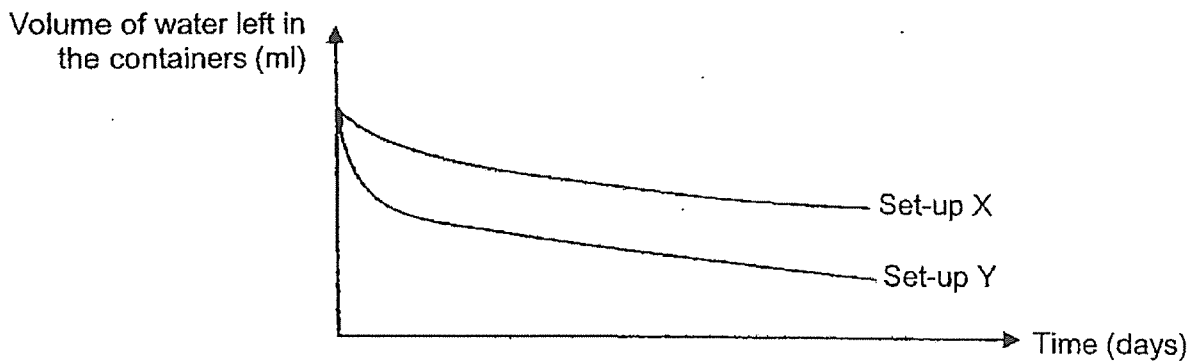

- (a) Based on the information above, which set-up has a bigger volume of water being absorbed by the roots? [1]

- (b) Based on the information above, state the relationship between the volume of water absorbed by the roots and the number of leaves of the plant. [1]

(Continues on next page)

SCORE	2
-------	---

- (c) Based on Mr Pang's set-up, which of the following variables need to be kept constant for this experiment to be a fair test?

Tick (✓) the correct box(es).

[2]

Variables	To be kept constant
Location of set-up	
Size of containers	
Number of leaves of the plant	
Volume of water left in container	

SCORE	2
-------	---

- 33 Lisa conducted an experiment to find out how the size of potato affects the rate of its digestion. She cut up each potato into different sizes and placed them in three beakers filled with equal volume of digestive juices as shown. The potato pieces in each beaker have the same total mass.

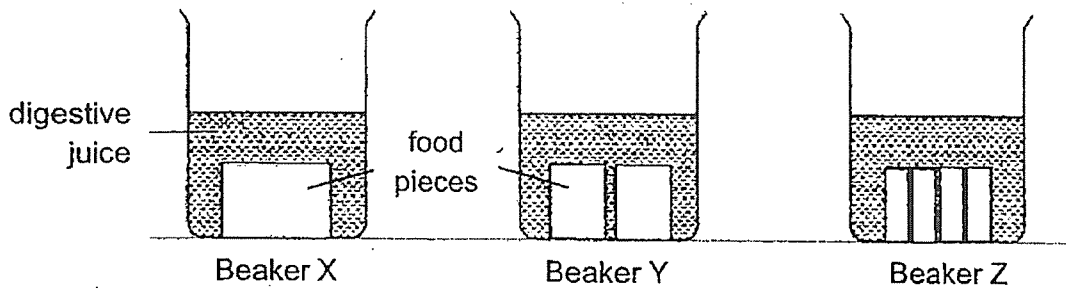

After two hours, Lisa measured the mass of the potato pieces left in each beaker and recorded the results in the table as shown below.

Beaker	Mass of potato pieces (g)	
	Start of experiment	End of experiment
X	100	91
Y	100	77
Z	100	52

- (a) Explain why the mass of the potato pieces in all the three beakers decreased. [1]

- (b) Based on the results, explain how chewing food well before swallowing affects the rate of digestion of food in a human. [2]

SCORE	3
-------	---

34 Jess compares the mass of three fruits, apple, orange and pear.

Study the diagrams below and circle the correct answer.

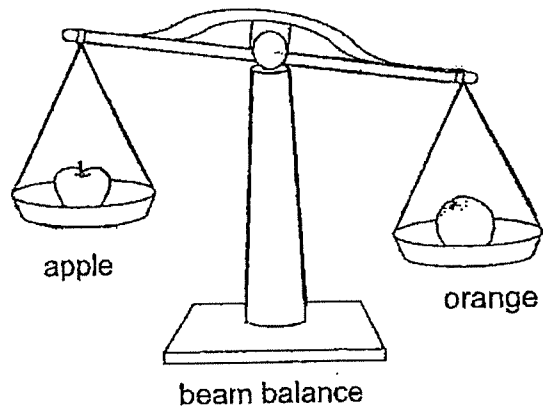

- (a) The apple has (a smaller mass than / a bigger mass than / the same mass as) the orange. [1]

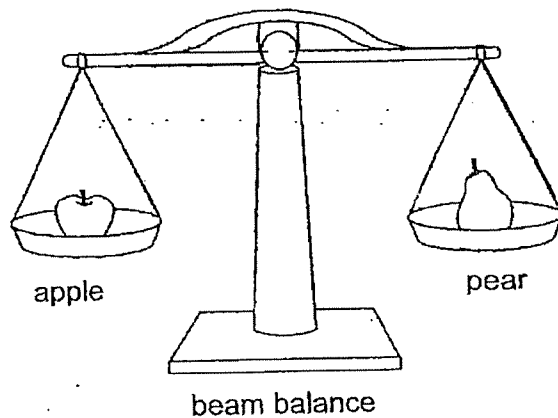

- (b) The pear has (a smaller mass than / a bigger mass than / the same mass as) the apple. [1]

SCORE	2
-------	---

35 The diagram below shows how Johnny sees his pet cat.

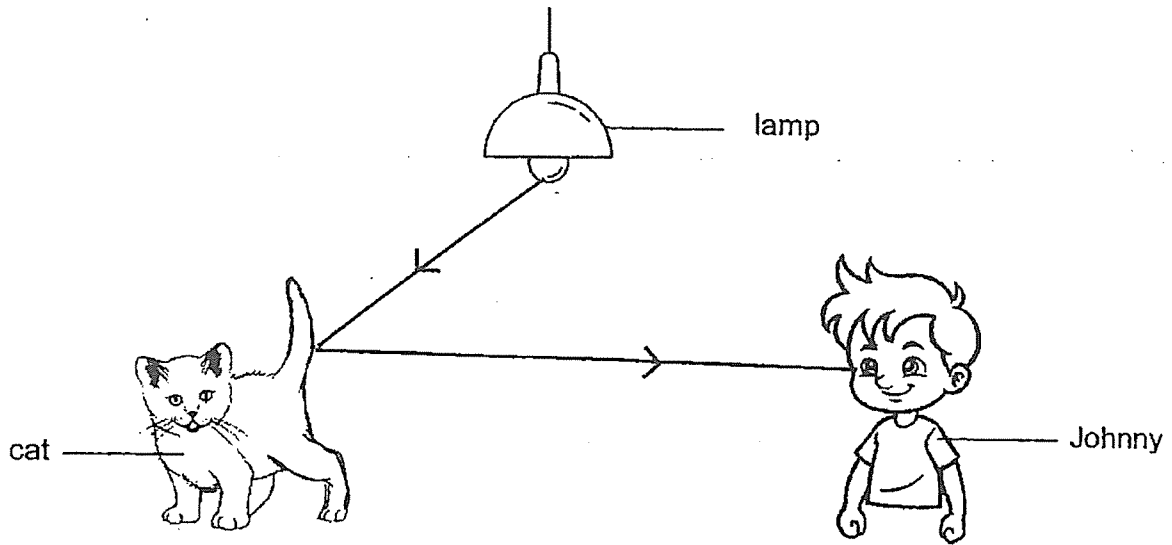

Fill in the blanks.

The _____ reflects _____ from the lamp into Johnny's eye. [2]

36 The diagram shows a beaker of water.

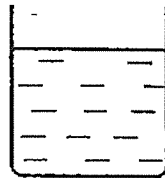

Fill in the blanks using the correct words in the box.

decreases	gas	increases
remains unchanged	solid	

(a) When the beaker of water is heated, its temperature

_____ [1]

(b) The beaker of water is put in the freezer. After some time, the water will change its state to become a _____ [1]

SCORE	4
-------	---

37 The diagram below shows how conveyor belt Q fitted with a bar magnet helps to sort out a bin of objects made of magnetic and non-magnetic materials into two separate containers, A and B.

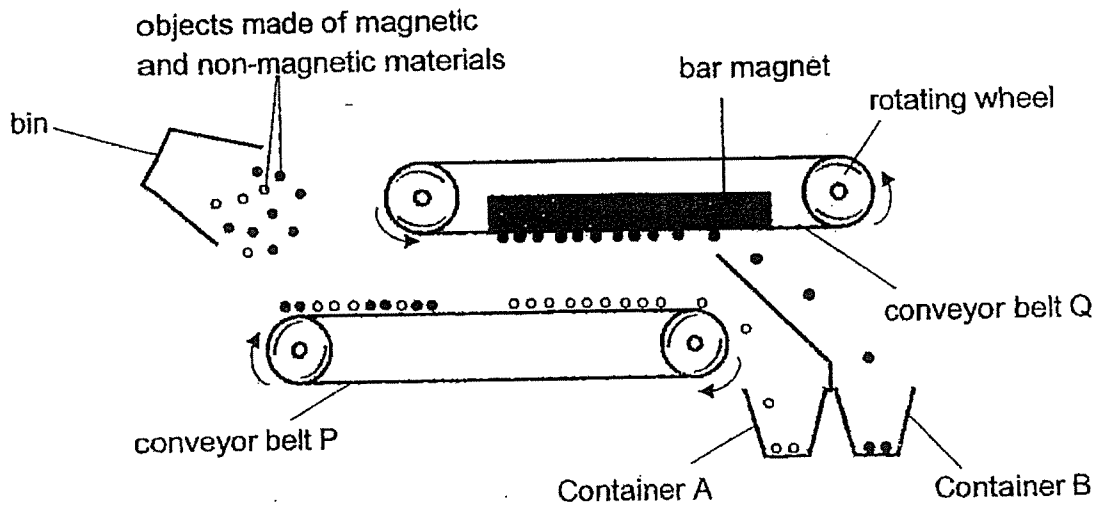

(a) Which containers, A or B, will contain objects made of: [2]

(i) Magnetic materials: Container: _____

(ii) Non-magnetic materials: Container: _____

(b) Explain your answer in (a). [2]

SCORE	4
-------	---

38 Qi Hang set up an experiment as shown below using material F.

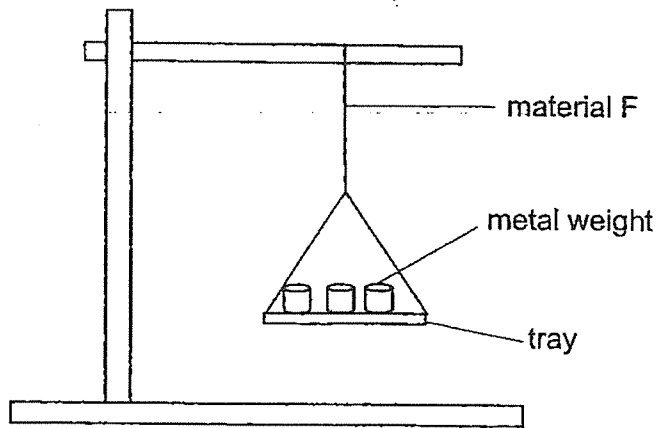

He gradually added metal weights of equal mass, one at a time on the tray, until material F broke. He repeated the experiment with two other different materials, G and H.

The table below shows his results.

Material	Number of metal weights the material could hold before it broke
F	5
G	12
H	8

(a) Which property of the material is Qi Hang testing? [1]

(b) Based on Qi Hang's set-up, what can he do to ensure that the experiment results are reliable? [1]

(Continues on next page)

SCORE	2
-------	---

The diagram below shows a school bag.

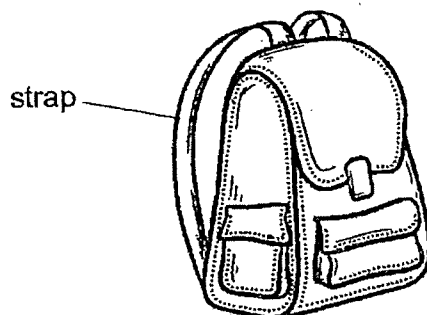

- (c) Based on Qi Hang's results, which material, F, G or H, is most suitable for making the strap for the school bag shown above? Explain your answer. [2]

SCORE	2
-------	---

39

Eric wants to classify oil, carbon dioxide, wooden block, and orange juice using the classification table below.

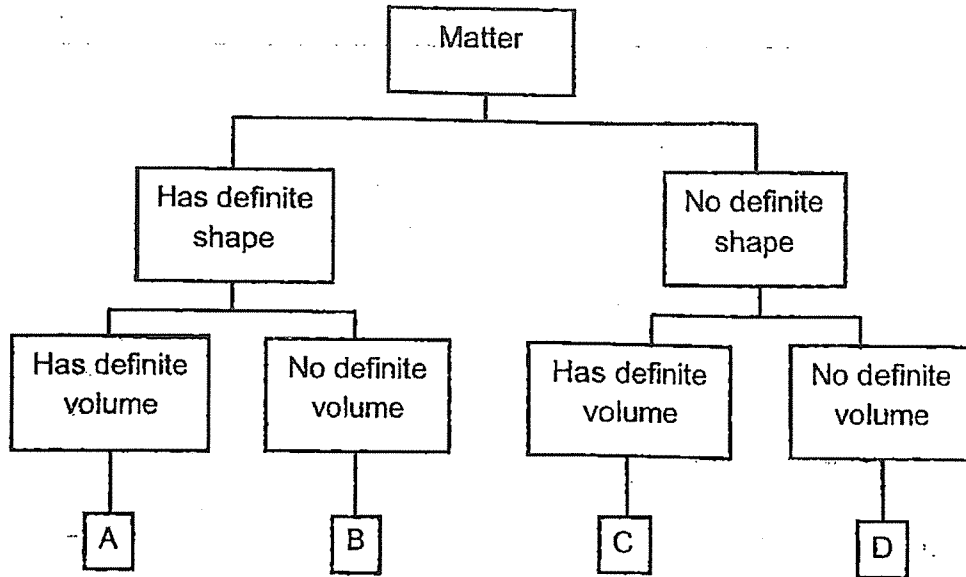

(a) Identify the matter by writing letter A, B, C or D in the table below. You may use the letters more than once. [2]

Matter	Letter
oil	
carbon dioxide	
wooden block	
orange juice	

(Continues on next page)

SCORE	2
-------	---

Eric removed the bottle cap of an empty bottle and pushed the bottle downwards into a container of water as shown in the diagram below.

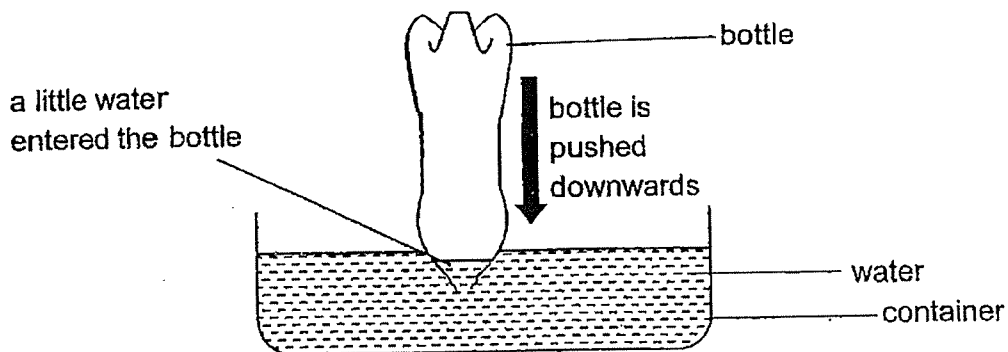

(b)(i) He observed that only a little water entered the bottle. Explain his observation. [1]

(b)(ii) Suggest what Eric could do to the bottle so that more water could enter the bottle when he pushed the bottle into the container of water. Explain your answer. [2]

SCORE	3
-------	---

- 40 Mrs Tan conducted an experiment by placing each material X and Y below a beaker of water and heated it over a bunsen burner as shown below.

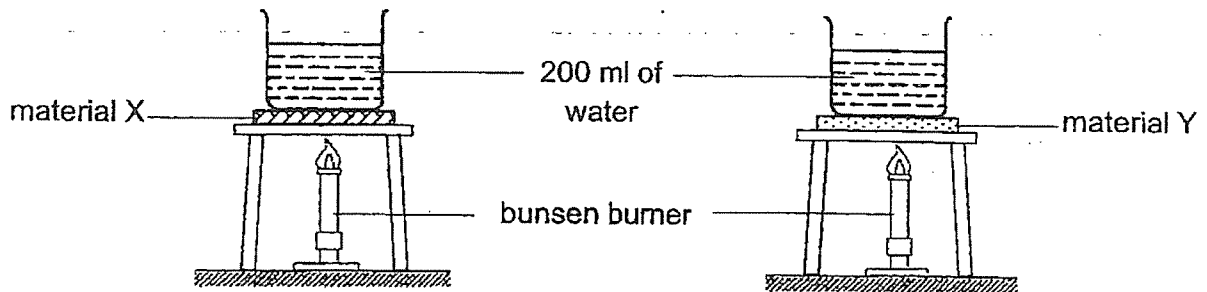

She recorded the time taken for the water to boil in the table below.

Material	Time taken for water to boil (min)
X	5
Y	8

- (a) State what is temperature.

[1]

- (b) State the aim of Mrs Tan's experiment.

[1]

(Continues on next page)

SCORE	/
	2

The diagram below shows a barbeque grill. Some sticks of satay are being cooked on it.

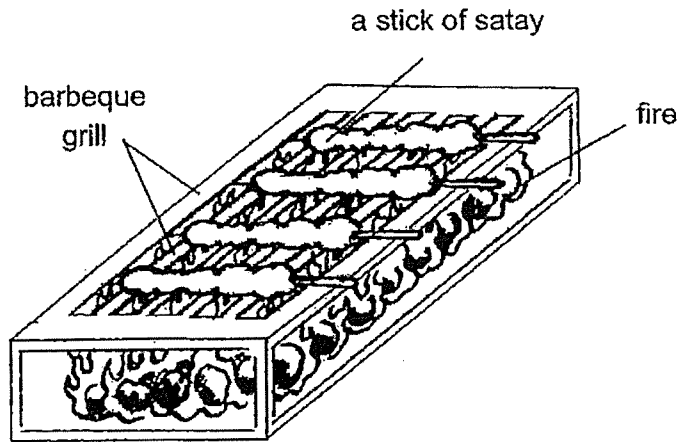

- (c) Based on Mrs Tan's results, which material, X or Y, is more suitable for making the barbeque grill so that the satay will be cooked faster? Explain your answer. [2]

SCORE	2
-------	---

- 41 Jed wanted to find out which material, A, B or C, is best at reflecting light. He used material A and set up his experiment inside an opaque box as shown below.

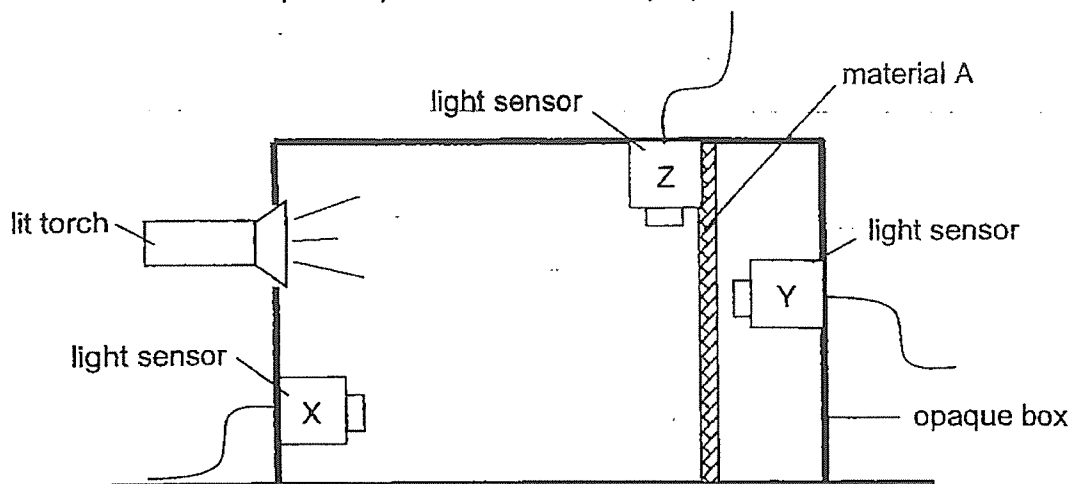

- (a) In the diagram above, which light sensor, X, Y or Z, should Jed use to detect the amount of light reflected by material A? [1]

- (b) Give a reason why Jed conducted his experiment in an opaque box. [1]

(Continues on next page)

SCORE	/
	2

Jed repeated the experiment using material B and C. He recorded the amount of light reflected by material A, B and C in the table below.

Material	Amount of light detected by light sensor (units)
A	150
B	60
C	280

Jed was driving home at night when he saw some traffic cones with reflective strips along the roadside where construction is taking place.

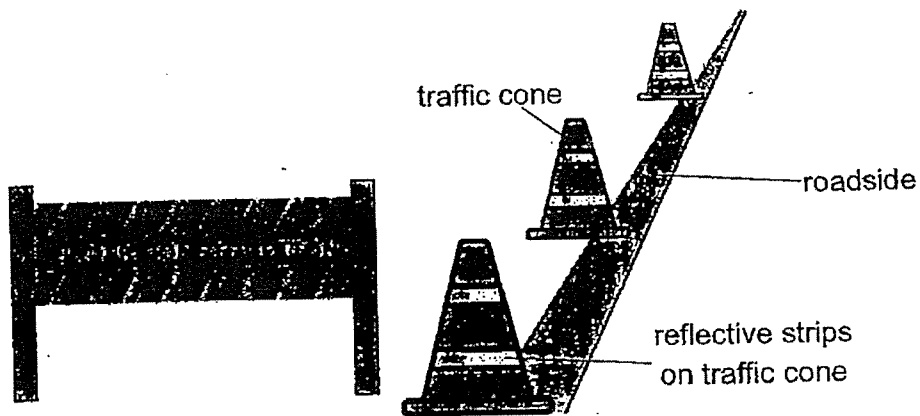

- (c) Based on Jed's results, which material, A, B or C, should be used to make the reflective strips on the traffic cones? Explain your answer. [2]

END OF PAPER

SCORE	
-------	--

SCHOOL : ST. HILDA'S PRIMARY SCHOOL
LEVEL : PRIMARY 4
SUBJECT : SCIENCE
TERM : 2023 SA2

SECTION A

Q 1	Q2	Q3	Q4	Q5	Q6	Q7	Q8	Q9	Q10
2	2	1	1	4	4	1	4	2	3
Q 11	Q12	Q13	Q14	Q15	Q16	Q17	Q18	Q19	Q20
3	1	2	4	3	3	1	2	3	4
Q 21	Q22	Q23	Q24	Q25	Q26	Q27	Q28		
3	2	3	2	4	4	4	3		

SECTION B

Q29)	a) D b) C
Q30)	a) (i) Nymph/young (ii) Grasshopper/dragonfly/chicken/frog b) Part RS. The amount of food eaten at part RS is zero showing that it is at pupa stage when it does not eat.
Q31)	a) Mammals b) Organism P does not breathe through lungs but organism Q breathes through lungs c) Yes. Fish does not breathe through lungs like organism P d) Mushroom. It reproduces by spores
Q32)	a) Set-up Y b) As the number of leaves decreases, the volume of water absorbed by plant decreases. c) Location of set-up and size of containers
Q33)	a) The digestive juice has broken down the potato pieces into simpler substances b) Chewing food increases the exposed surface area of potato pieces in contact with digestive juices thus increasing rate of digestion
Q34)	a) Apple has smaller mass than orange b) Pear has the same mass as the apple

Q35)	The cat reflects light from the lamp into Johnny's eyes										
Q36)	a) When the beaker of water is heated, its temperature increases b) After some time, the water will change its state to become a solid										
Q37)	a) (i) Magnetic materials: B (ii) Non-magnetic materials: A b) The magnetic objects are attracted to bar magnet and will drop into container B. The non-magnetic objects are not attracted to the bar magnet and fall into container A										
Q38)	a) Strength b) Repeat the experiment 3 times to find the average. c) Material G. It could hold the most number of weights before it broke. This shows that it is the strongest material and will not break easily when used as a bag strap.										
Q39)	a) <table border="1" data-bbox="416 920 1369 1207"> <thead> <tr> <th>Matter</th> <th>Letter</th> </tr> </thead> <tbody> <tr> <td>Oil</td> <td>C</td> </tr> <tr> <td>Carbon dioxide</td> <td>D</td> </tr> <tr> <td>Wooden block</td> <td>A</td> </tr> <tr> <td>Orange juice</td> <td>C</td> </tr> </tbody> </table> <p>b) (i) Air in the bottle can be compressed so some water entered the bottle to occupy the space of the compressed air (ii) He can poke holes in the bottle so that air in the bottle can escape and water can enter into the bottle to occupy space previously occupied by escape air.</p>	Matter	Letter	Oil	C	Carbon dioxide	D	Wooden block	A	Orange juice	C
Matter	Letter										
Oil	C										
Carbon dioxide	D										
Wooden block	A										
Orange juice	C										
Q40)	a) Temperature is measurement of how hot or cold an object is b) Find out how the type of material affects the time taken for water to boil c) Material X. Time taken for the beaker of water placed above X to boil is shorter than that of Y. Hence X is a better conductor of heat and it will conduct heat faster from heat source to food.										
Q41)	a) Light sensor X b) To ensure that the surrounding light does not affect the amount of light detected by the light sensor c) Material C. The amount of light detected by the light sensor is the highest showing C is the most reflective material, hence it will reflect the most light into the driver's eye allowing him to see more clearly at night.										