

**CATHOLIC HIGH SCHOOL**  
**END-OF-YEAR EXAMINATION (2023)**  
**PRIMARY FOUR**  
**SCIENCE**  
**BOOKLET A**

Name: \_\_\_\_\_ ( )

Class: Primary 4 - \_\_\_\_\_

Date: 26 October 2023

28 questions

56 marks

Total Time for Booklets A and B: 1 hour 30 minutes

**INSTRUCTIONS TO CANDIDATES**

Do not turn over this page until you are told to do so.

Follow all instructions carefully.

Answer all questions.

Shade your answers in the Optical Answer Sheet (OAS) provided.

This booklet consists of 18 printed pages, excluding the cover page.



**Booklet A (28 × 2 marks)**

For each question from 1 to 28, four options are given. One of them is the correct answer. Make your choice (1, 2, 3 or 4). Shade your answer on the Optical Answer Sheet. (56 marks)

- 1 A lizard will break its tail when it is touched.

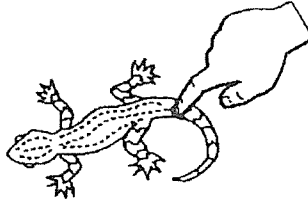

This shows that the lizard is a living thing because it can \_\_\_\_\_.

- (1) grow
- (2) breathe
- (3) respond
- (4) reproduce

- 2 The diagram shows how some living things can be grouped.

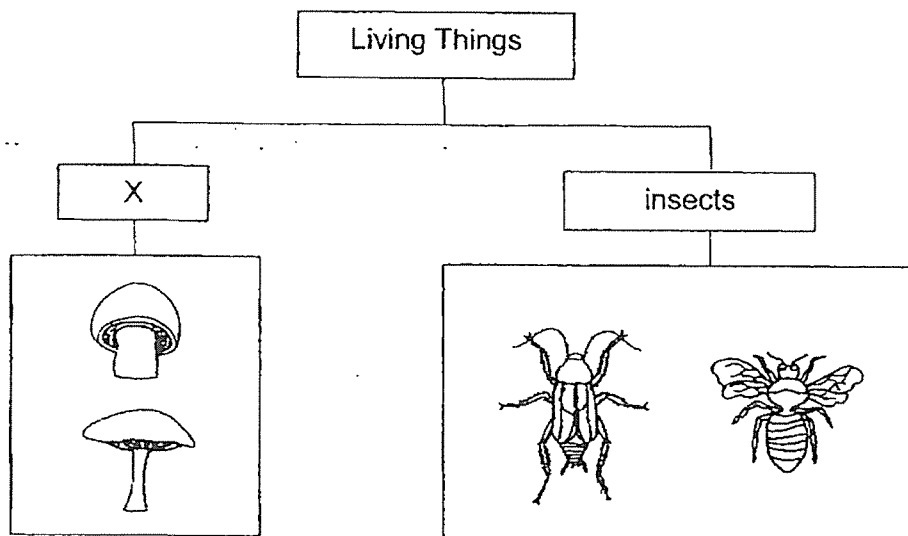

Which is the most suitable heading for group X?

- (1) fern
- (2) fungi
- (3) bacteria
- (4) mammals

3 Which object is not made of a waterproof material?

(1)

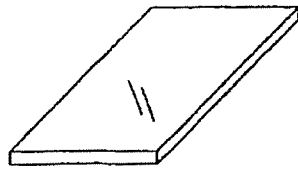

a sheet of glass

(2)



an umbrella

(3)

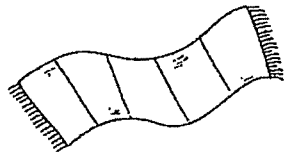

a towel

(4)

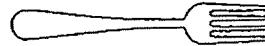

a plastic fork

4 In which part of the digestive system is food absorbed into the blood?

(1) gullet

(2) stomach

(3) large intestine

(4) small intestine

5 Which substance has a fixed shape?

(1) air

(2) oil

(3) water

(4) pebble

6 Which part, (1), (2), (3) or (4), takes in water for the plant?

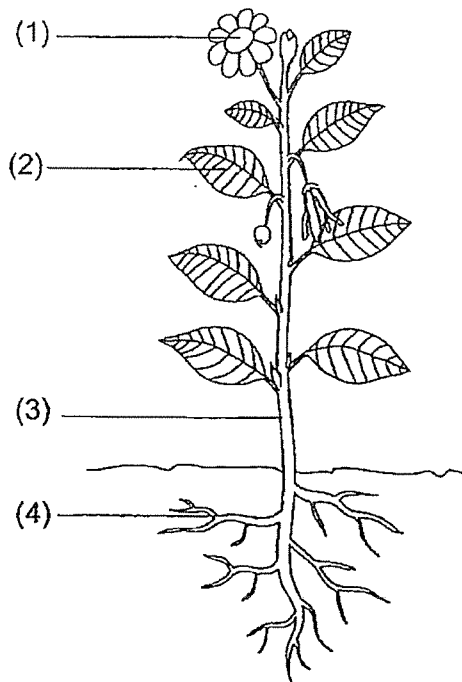

7 In which of the following will the two magnets push each other away?

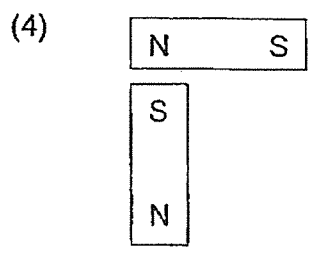
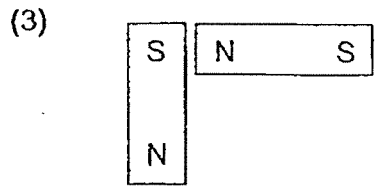
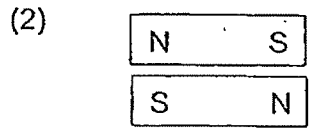
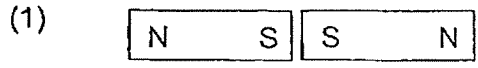

- 8 The diagram shows the growth of a young plant with two missing stages P and Q.

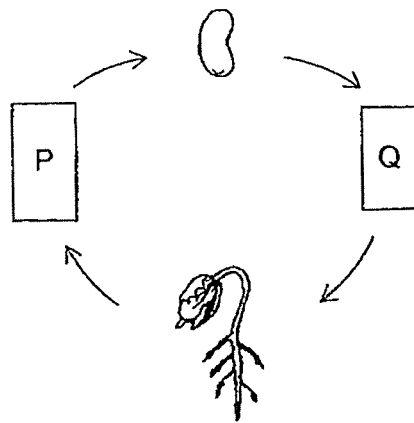

Which diagram shows the correct stages for P and Q?

	P	Q
(1)		
(2)		
(3)		
(4)		

9 Which object is a source of light?

(1)

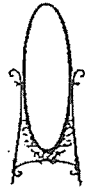

a mirror

(2)

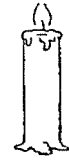

a candle flame

(3)



a pear

(4)



the moon

10 Kingston wants to measure the temperature of hot water in a beaker.

Which diagram shows the correct position of the thermometer when taking the temperature reading?

(1)

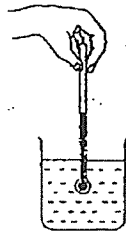

(2)

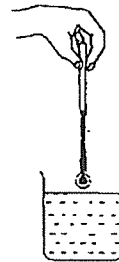

(3)

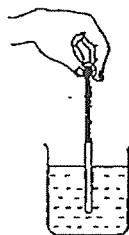

(4)

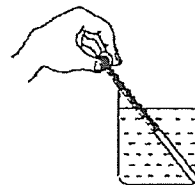





11 Animal Y has the following characteristics.

- It has lungs.
- It has moist skin.
- It lives on land and in water.

Which group does animal Y belong to?

- (1) fish
- (2) birds
- (3) reptiles
- (4) amphibians

12 Alison conducted an experiment to find out how temperature affects the growth of mould. She put pieces of similar bread each at places with different temperatures. She recorded her observations as shown.

Temperature at which the bread was left	5 °C	12 °C	18 °C	25 °C
Observations of the bread after two weeks				

Based on the observations, what is the relationship between temperature and the growth of mould?

	Temperature	Growth of mould
(1)	increases	increases
(2)	increases	remains the same
(3)	decreases	decreases
(4)	decreases	increases



- 13 The graph shows the number of days for each stage of the life cycle of animal W.

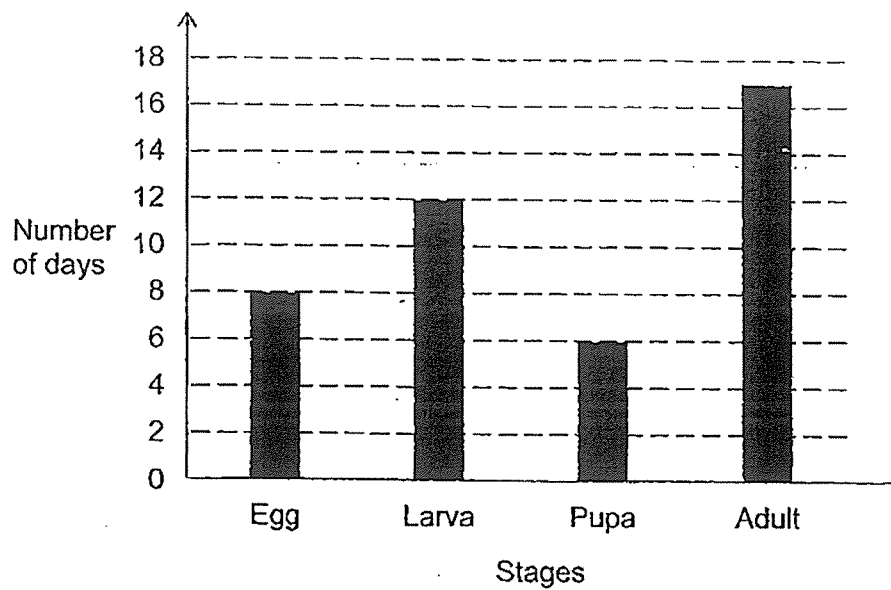

At which stage of the life cycle is animal W on the 17<sup>th</sup> day after the egg is laid?

- (1) egg
- (2) larva
- (3) pupa
- (4) adult

14 Study the diagram.

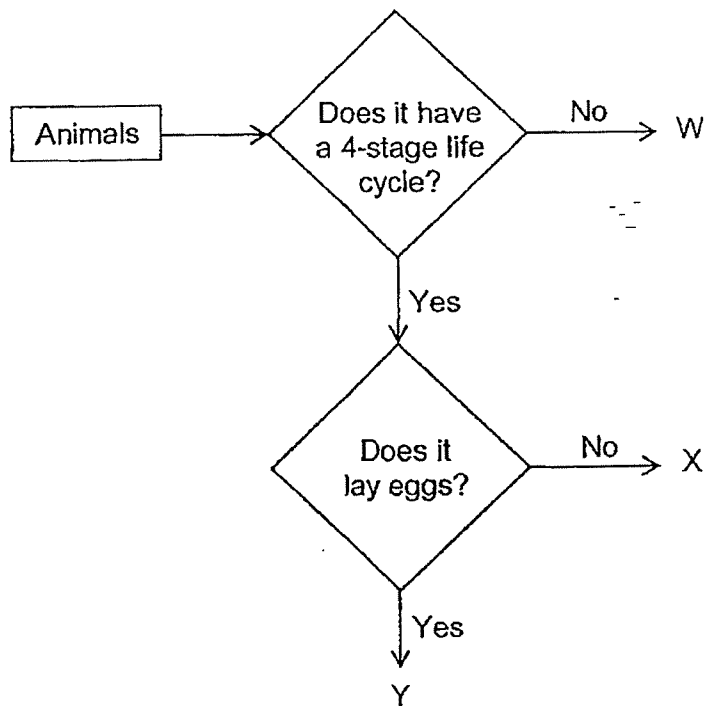

Based on the diagram, which statement(s) is/are correct?

- A X has a 4-stage life cycle.
  - B W has a 3-stage life cycle.
  - C Y gives birth to young alive.
- (1) B only  
(2) A and B only  
(3) A and C only  
(4) A, B and C

- 15 The table shows four materials, A, B, C and D, and their properties. A tick (✓) indicates the presence of the property in the material.

Property	Material			
	A	B	C	D
flexible			✓	✓
waterproof	✓	✓		
ability to float on water		✓		✓

Which material is most suitable to make a shirt?

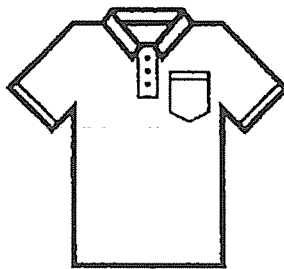

- (1) A  
 (2) B  
 (3) C  
 (4) D
- 16 Derek wanted to find out if increasing the number of coils of wire would affect the strength of an electromagnet. The table shows the results.

Set-up	Number of batteries	Number of coils of wire
A	2	10
B	2	5
C	3	10
D	3	5

Which two set-ups should he use?

- (1) A and B only  
 (2) A and D only  
 (3) B and C only  
 (4) B and D only

17 The diagram shows a magnet taped onto a styrofoam board.

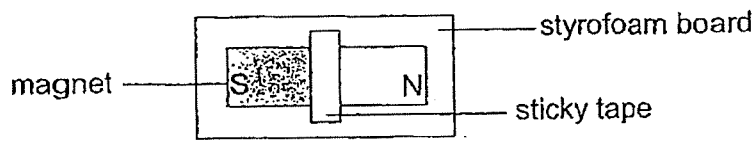

Riyan wanted to find out the position in which the magnet would come to rest. He placed it into a basin of water to float freely as shown.

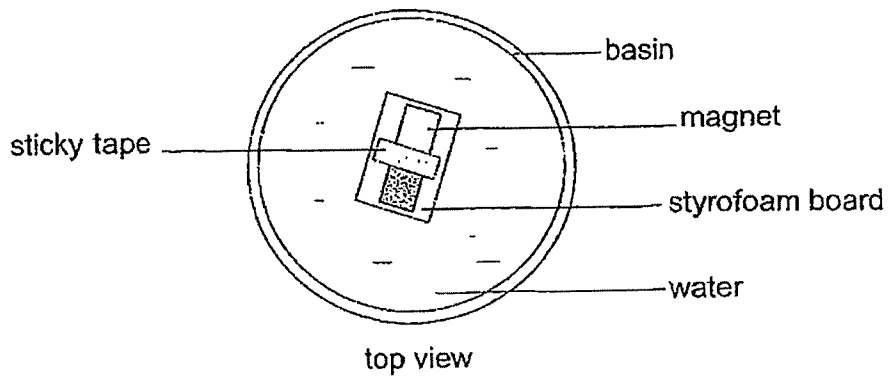

Which diagram shows what he would observe when the magnet came to rest?

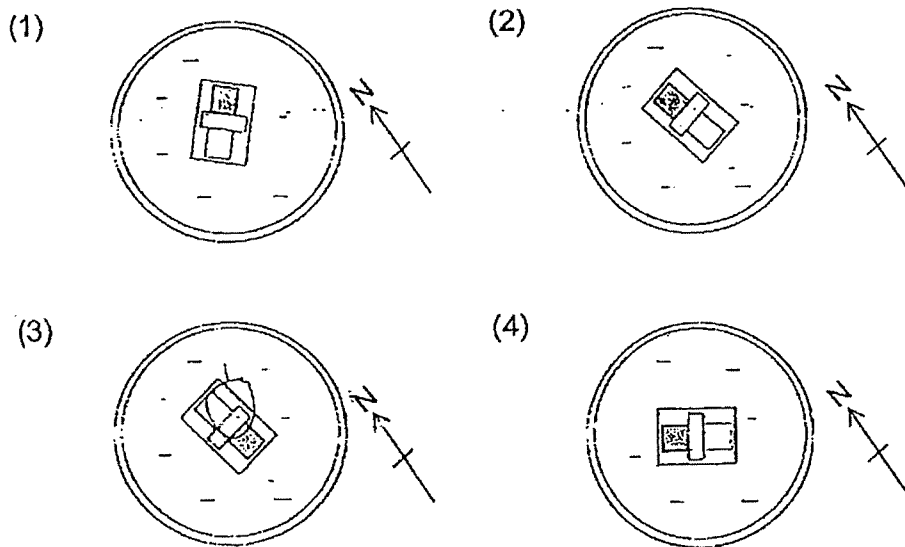

18 Container F has 400 ml of water.

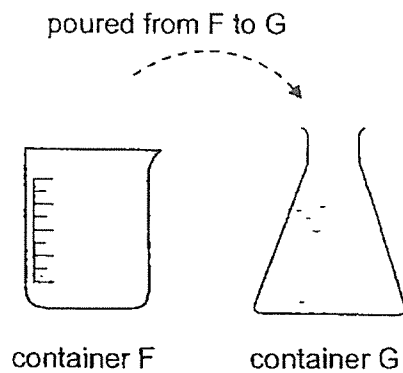

Which of the following will remain the same when all the water is poured from container F to container G, with no loss of water?

- A mass of water
- B shape of water
- C volume of water

- (1) B only
- (2) C only
- (3) A and B only
- (4) A and C only

19 Zhi Wei pumps  $300 \text{ cm}^3$  of air into an air-tight bottle through a pump as shown. The capacity of the air-tight bottle is  $1000 \text{ cm}^3$ .

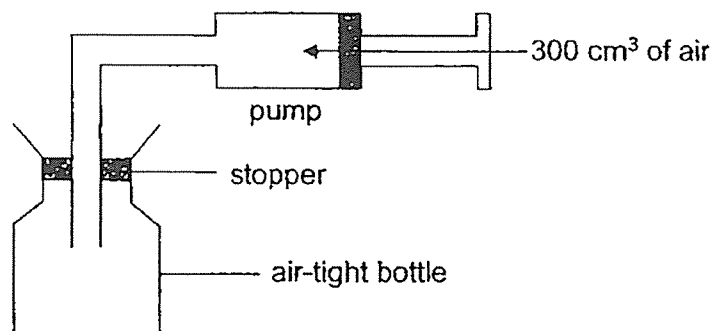

What is the final volume of air in the air-tight bottle?

- (1)  $300 \text{ cm}^3$
- (2)  $700 \text{ cm}^3$
- (3)  $1000 \text{ cm}^3$
- (4)  $1300 \text{ cm}^3$

20 A cup of water and a cube are placed on a balance scale as shown.

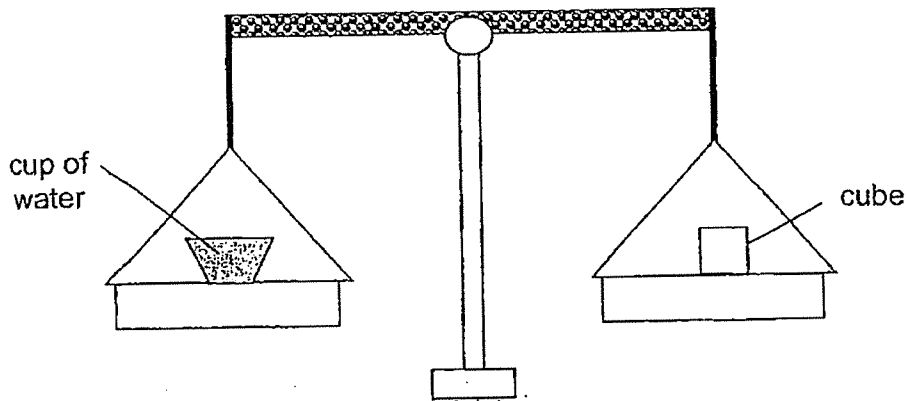

Which statement is correct?

The cup of water and the cube \_\_\_\_\_.

- (1) have the same mass
- (2) have the same volume
- (3) occupy the same amount of space
- (4) have different mass and different volume

21 Ranjani placed a wooden block at positions, X, Y and Z, as shown. At each position, she measured the height of the shadow cast on the screen.

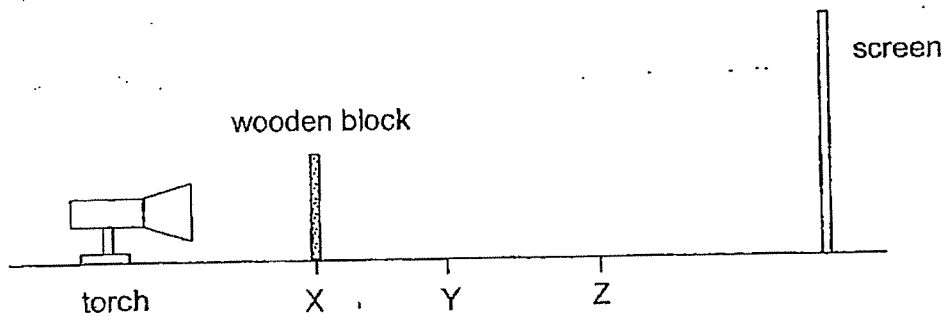

Which is the correct height of the shadows recorded for positions, X, Y and Z?

Height of shadow cast on screen (cm)			
	X	Y	Z
(1)	30	18	12
(2)	18	18	18
(3)	18	12	30
(4)	12	18	30

22 Wei Jie set up an experiment as shown using object A.

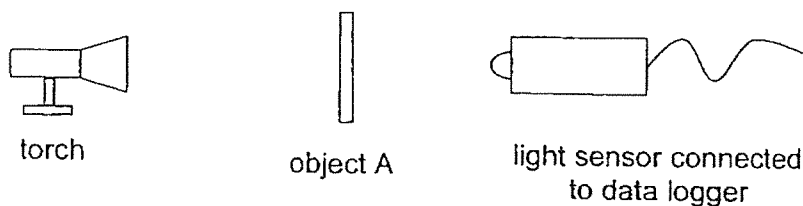

He repeated the experiment using objects B and C. The three objects are made of different materials of similar size and thickness. He recorded the amount of light using a light sensor connected to the data logger.

Object	Amount of light detected by data logger (units)
A	400
B	150
C	0

What was the aim of Wei Jie's experiment?

To find out how \_\_\_\_\_.

- (1) the amount of light detected by the data logger affects the material of the object
- (2) the size of an object affects the amount of light allowed to pass through the object
- (3) the material of an object affects the amount of light allowed to pass through the object
- (4) the thickness of an object affects the amount of light allowed to pass through the object

23 Study the diagram.

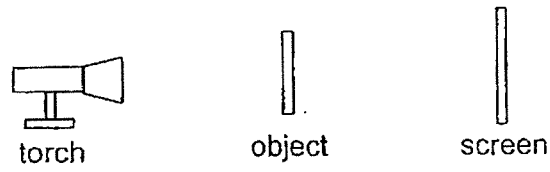

The object is made of different materials as shown.

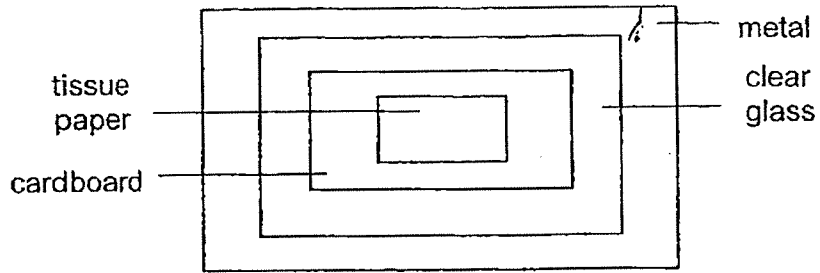

Key:



Which shadow would likely be formed on the screen?

- (1)
- (2)
- (3)
- (4)



24 Study the diagram.

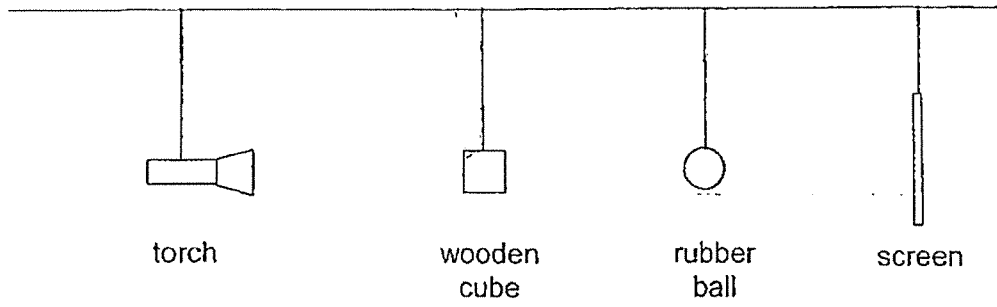

The dimensions of the objects are as shown.

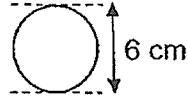
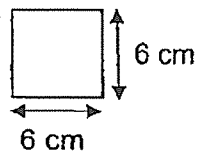

Which shadow would likely be formed on the screen?

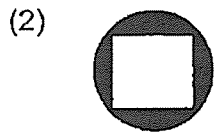
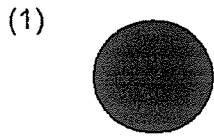

25 A cup of ice cream melted after it was taken out from a freezer.

Why did the ice cream melt?

- (1) The cup lost heat to the surrounding air.
- (2) The cup gained heat from the ice cream.
- (3) The ice cream lost heat to the surrounding air.
- (4) The ice cream gained heat from the surrounding air.

26 Farah poured some hot water into a basin. She then put a glass of ice cubes into it.

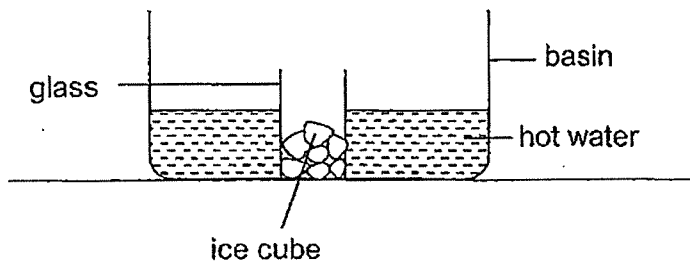

Which objects will gain heat?

- A basin
- B glass
- C hot water
- D ice cubes

- (1) A and D only
- (2) B and C only
- (3) A, B and D only
- (4) A, B, C and D

27 Study the diagram.

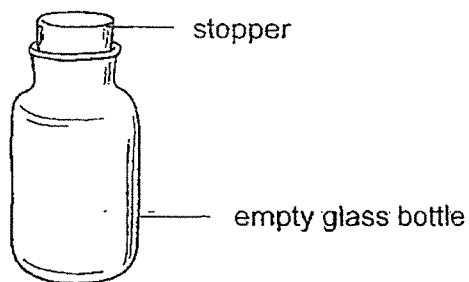

When the empty glass bottle is put near a fire, the stopper pops out because the \_\_\_\_\_.

- (1) air in the bottle gains heat and expands
- (2) air in the bottle loses heat and contracts
- (3) glass bottle gains heat and expands
- (4) glass bottle loses heat and contracts

- 28 Leroy wanted to find out which rod, X, Y or Z, was the best conductor of heat. He placed a blob of wax at the end of each rod. He then placed the rods into a cup of boiling water as shown.

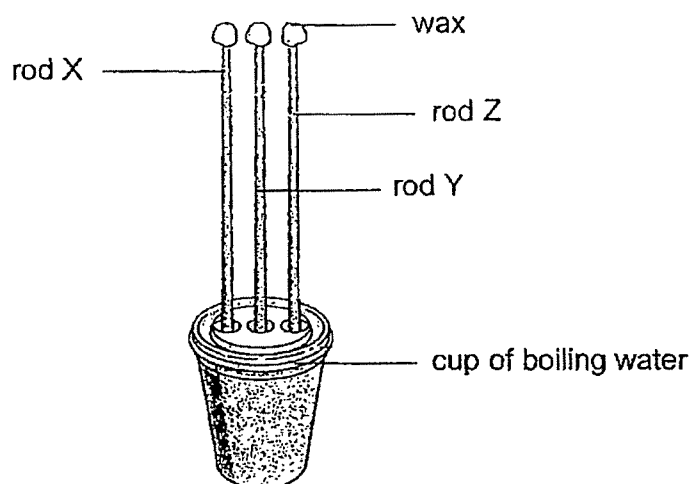

The time taken for each blob of wax to drop off the rods was recorded in the table.

Rod	Time taken for the blob of wax to drop (min)
X	2
Y	5
Z	3

Based on the results, which statement(s) is/are correct?

- A Rod X is a better conductor of heat than rod Y.
- B Rod X is a better conductor of heat than rod Z.
- C Rod Y is a better conductor of heat than rod Z.

- (1) C only
- (2) A and B only
- (3) A and C only
- (4) B and C only

End of Booklet A

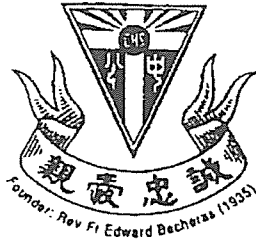

**CATHOLIC HIGH SCHOOL**  
**END-OF-YEAR EXAMINATION (2023)**  
**PRIMARY FOUR**  
**SCIENCE**  
**BOOKLET B**

Name: \_\_\_\_\_ ( )

Class: Primary 4 - \_\_\_\_\_

Date: 26 October 2023

Parent's Signature: \_\_\_\_\_

Booklet A	56
Booklet B	44
Total	100

13 questions

44 marks

Total Time for Booklets A and B: 1 hour 30 minutes

**INSTRUCTIONS TO CANDIDATES**

Do not turn over this page until you are told to do so.

Follow all instructions carefully.

Answer all questions.

Write your answers in this booklet.

This booklet consists of 14 printed pages, excluding the cover page.

**Booklet B (44 marks)**

For questions 29 to 41, write your answers in this booklet.

The number of marks available is shown in brackets [ ] at the end of each question or part question. (44 marks)

29 Study the diagram.

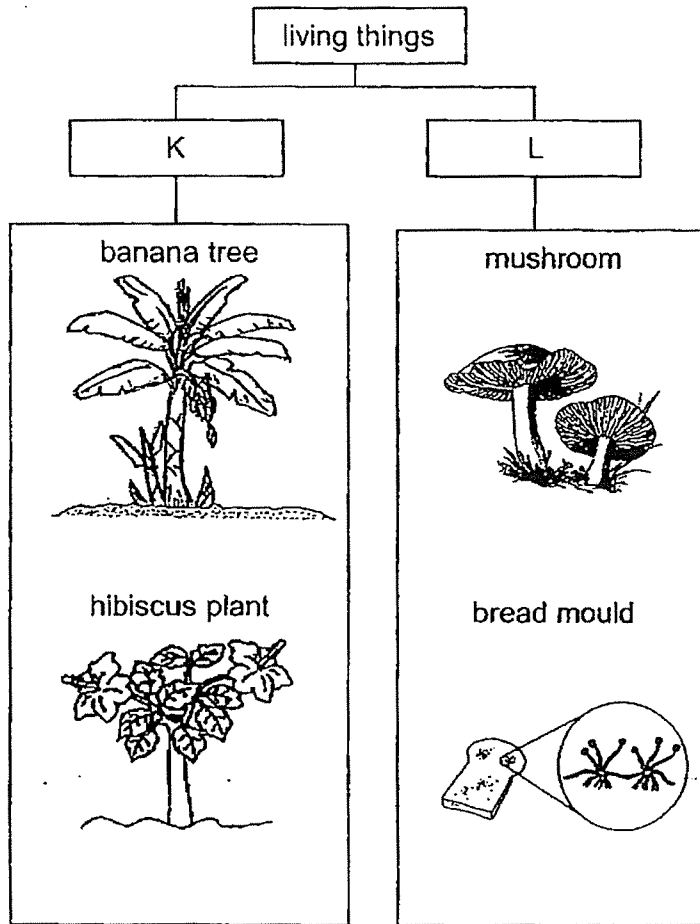

Choose the correct words from the box to give suitable headings for K and L.

flowering plants    non-flowering plants    bacteria    fungi

[2]

K: \_\_\_\_\_

L: \_\_\_\_\_

(Go on to the next page)

SCORE	2
-------	---

30 The diagram shows two plants.

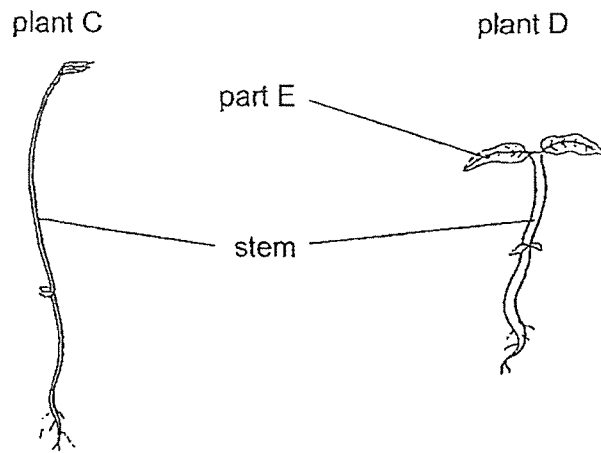

(a) What is one difference between the stem of plant C and the stem of plant D? [1]

The stem of plant C is \_\_\_\_\_ than the stem of plant D.

(b) Part E helps plant D make \_\_\_\_\_ in the light. [1]

31 The diagram shows a bottle of juice.

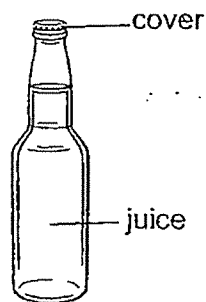

Complete the sentences to state if the parts are solid, liquid or gas.

(a) The cover is a \_\_\_\_\_ . [1]

(b) Juice is a \_\_\_\_\_ . [1]

(Go on to the next page)

SCORE	4
-------	---

32 Puvanesh places a magnet near an iron rod.

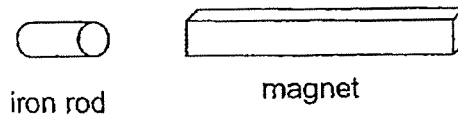

(a) The iron rod moves towards the magnet. The magnet exerts a \_\_\_\_\_ on the iron rod. [1]

(b) Choose the correct word from the box to answer the question below.

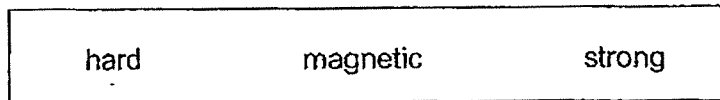

Puvanesh's observation shows that iron is a \_\_\_\_\_ material. [1]

33 The diagram shows how Lucian sees a ball

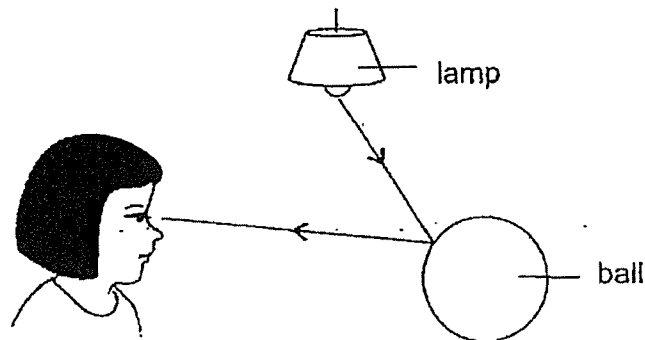

(a) The \_\_\_\_\_ from the lamp is \_\_\_\_\_ by the ball and enters Lucian's eye. [2]

(Go on to the next page)

SCORE	4
-------	---



Continue from Question 33

Lucian wanted to investigate which material was the best at reflecting light. He set up his experiment in a dark room as shown.

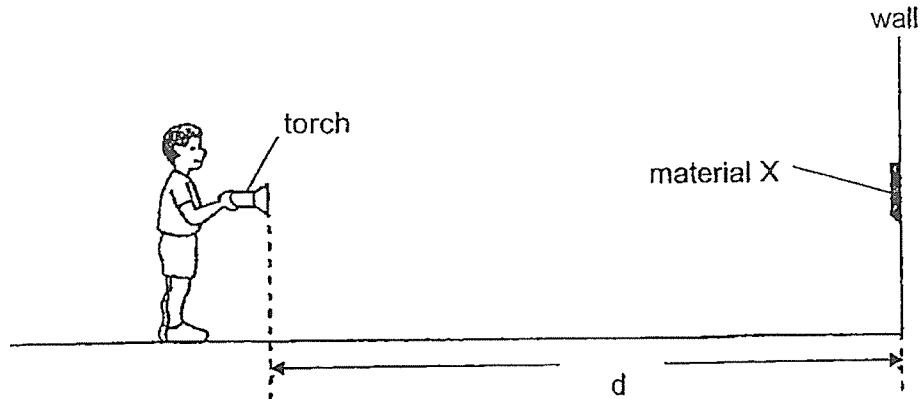

He shone the light from the torch onto material X and walked towards it. When he could clearly see the material, he stopped and measured the distance,  $d$ , between the torch and the wall. He repeated the experiment with materials, Y and Z, each time. His results are as shown.

Material	X	Y	Z
$d$ (cm)	300	330	360

- (b) Based on the table, which material should be used to make a helmet for the cyclist to wear at night so that other drivers can see him most clearly from the furthest distance? Give a reason.

[1]

---

---

- (c) Name the equipment Lucian could use to measure the amount of light reflected by the material more accurately.

[1]

---

(Go on to the next page)

SCORE	2
-------	---

34 Ariz placed a strip of material A across two tables as shown.

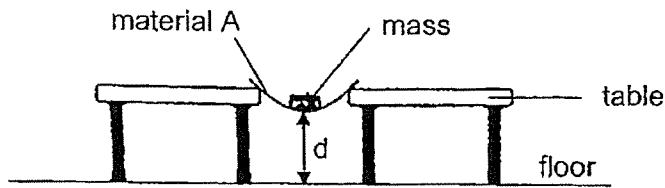

He tested the material by adding masses to it. He recorded the distance,  $d$ , from the floor to the bottom of the material for different masses. He repeated his experiment by replacing material A with material B. His results are as shown.

Mass added to material (g)	d (cm)	
	Material A	Material B
0	10	10
10	8	10
20	6	9
30	4	9

(a) Name the property of the material that Ariz is testing and state what it means. [2]

---



---

(b) Based on his results, state how the mass added to the material affects the distance,  $d$ . [1]

---



---

(Go on to the next page)

SCORE	3
-------	---

Continue from Question 34

The diagram shows an umbrella.

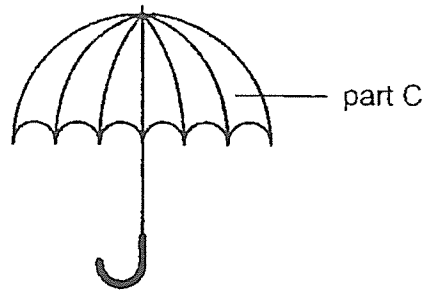

- (c) Based on his results, which material, A or B, is more suitable to make part C of the umbrella? Explain why.

[1]

---

---

(Go on to the next page)

SCORE	1
-------	---

35 The diagram shows the human digestive system.

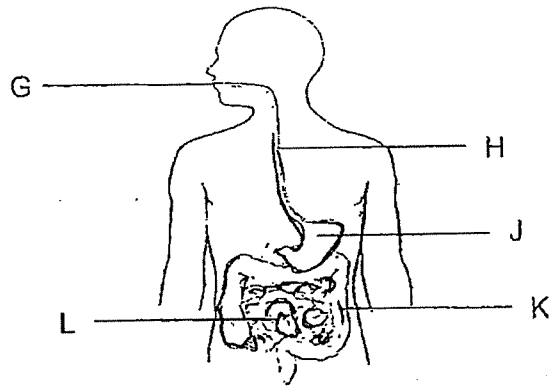

(a) In which part(s) of the system, G, H, J, K or L, do/does digestion take place? [1]

\_\_\_\_\_

(b) State the function of part K. [1]

\_\_\_\_\_

The graph shows the amount of digested food that passed through different organs in the digestive system.

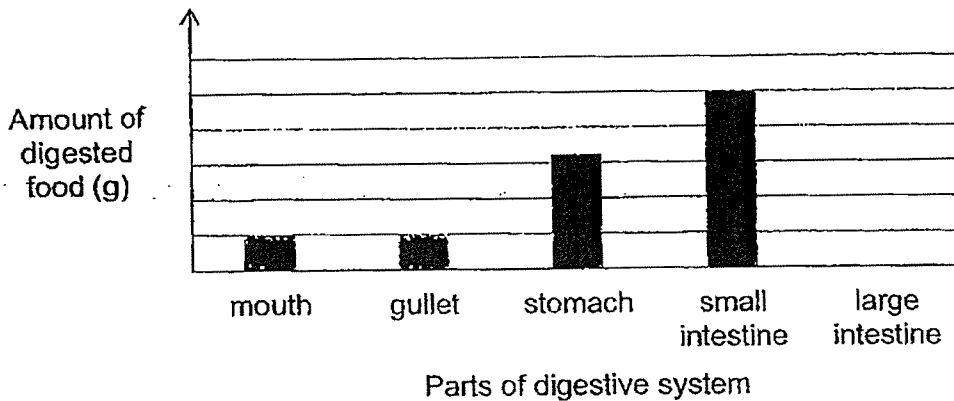

(c) Based on the graph, why is the amount of digested food in the mouth and gullet the same? [1]

\_\_\_\_\_

(d) Based on the graph, why is there no digested food present in the large intestine? [1]

\_\_\_\_\_

(Go on to the next page)

SCORE	4
-------	---

36 Study the set-up.

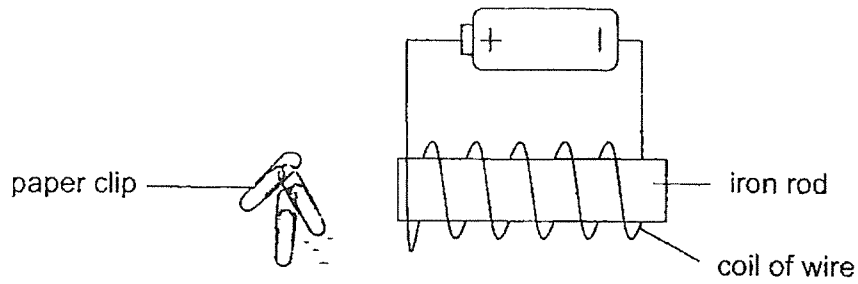

- (a) State what would be observed when some paper clips were placed at the end of the iron rod. [1]

---

---

- (b) Explain your answer in (a). [1]

---

---

- (c) State what would be observed if the paper clips were replaced by a wooden toothpick. [1]

---

---

- (d) State what would be observed if the battery was removed from the set-up. Explain why. [1]

---

---

(Go on to the next page)

SCORE	/
	4

37 Study the diagram.

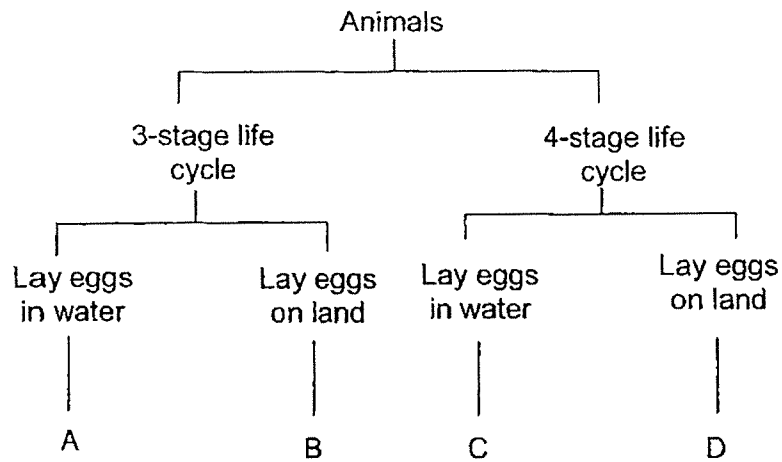

(a) State one similarity between animals A and C. [1]

---

---

(b) State one difference between animals B and D. [1]

---

---

(c) Which letters, A, B, C or D, represent the following animals? [2]

(i) frog : \_\_\_\_\_

(ii) butterfly: \_\_\_\_\_

(Go on to the next page)

SCORE	
	4

38 Zeus set up an experiment as shown. He used a straw to blow air into the inverted cup.

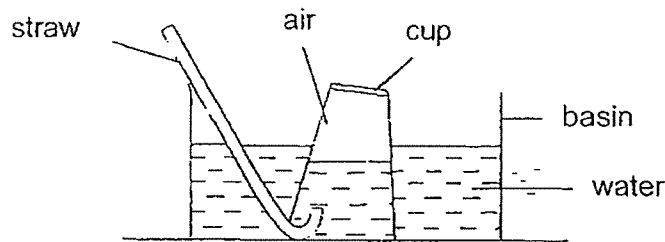

(a) He observed that the water level in the cup decreased once he started blowing air into the cup. Explain why. [2]

---

---

---

Zeus removed the straw and observed that the water level in the cup was lower than that in the basin as shown.

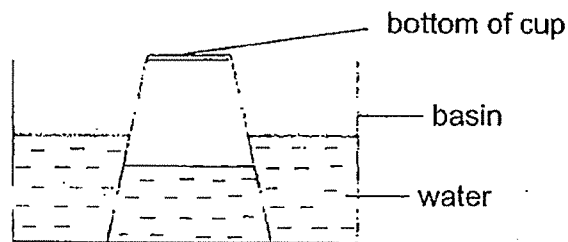

(b) State what would happen to the water level in the cup if Zeus makes a hole at the bottom of the cup. Explain why. [2]

---

---

---

(Go on to the next page)

SCORE	4
-------	---

39 Study the set-up.

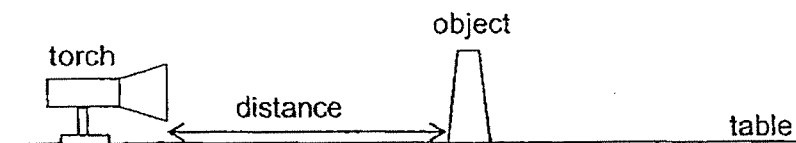

Cassandra measured the change in the length of the object's shadow on the table when the object was placed at different distances from the light source. The table shows the results of her experiment.

Distance of object from the light source (cm)	Length of shadow on the table (cm)
10	7.5
20	15.5
30	23.5

(a) What was Cassandra trying to find out from her experiment? [1]

---



---

(b) Explain how the shadow of the object was formed on the table. [2]

---



---



---

(c) Put a tick (✓) in the boxes next to the variable that Cassandra changed and kept the same to make her experiment a fair test. [1]

Variables	Changed	Kept the same
type of torch		
distance of object from light source		
length of shadow		

(Go on to the next page)

SCORE	4
-------	---



- 40 Russell recorded the temperature of air in a glass bottle. He heated some sand and poured them into the bottle. After 15 minutes, he recorded the temperature of air in the bottle.

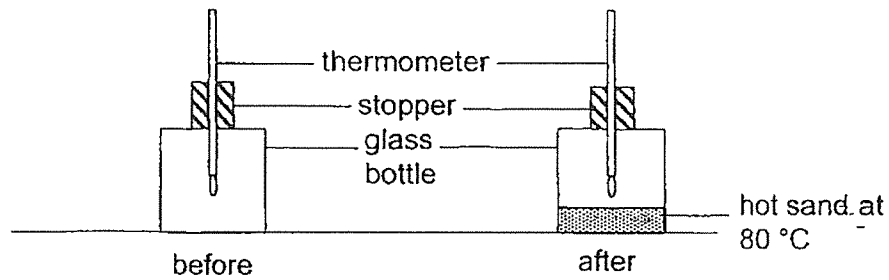

The results are as shown.

Temperature of air in the glass bottle	
Before sand was poured in	After sand was poured in
30 °C	40 °C

- (a) Explain why there was an increase in the temperature of air in the bottle after sand was poured in. [1]

---



---

Russell repeated the same experiment with a metal bottle. The table shows the results.

Temperature of air in the metal bottle	
Before sand was poured in	After sand was poured in
30 °C	33 °C

- (b) Explain why the temperature of air in the metal bottle was lower than that in the glass bottle [2]

---



---



---

- (c) State what happens to the temperature of the sand after two hours. [1]

---



---

(Go on to the next page)

SCORE	4
-------	---

41 Iskandar poured an equal amount of boiling water into three identical flasks, wrapped in three different materials.

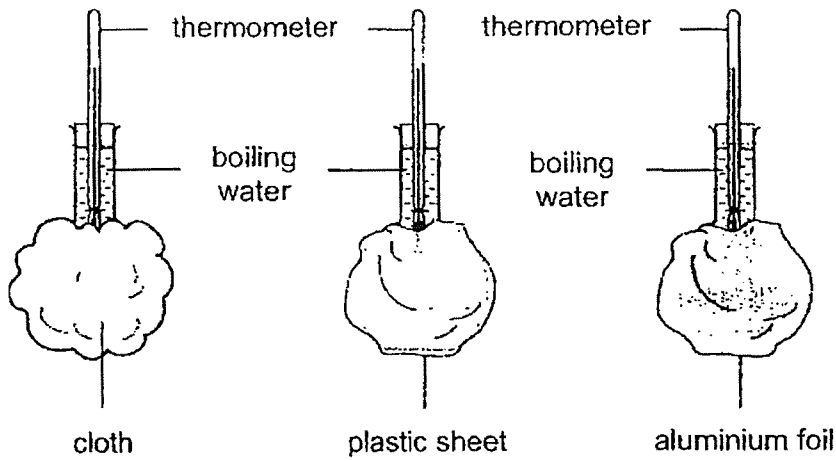

He measured the time taken for the water in the three flasks to reach 30 °C. His results were recorded in the graph.

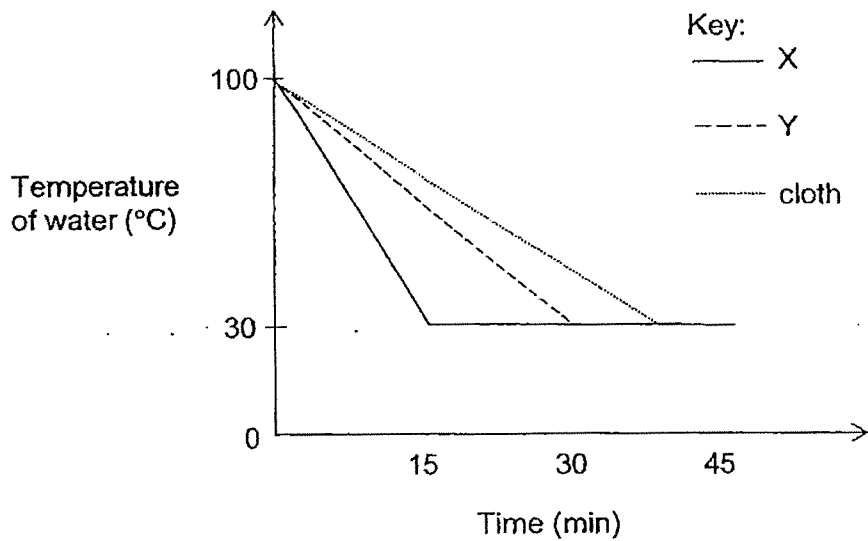

(a) Based on the graph, which line, X or Y, represents the aluminium foil? [1]

\_\_\_\_\_

(Go on to the next page)

SCORE	1
-------	---

Continue from Question 41

Iskandar wanted to keep the food hot and the drink cold for the longest time.

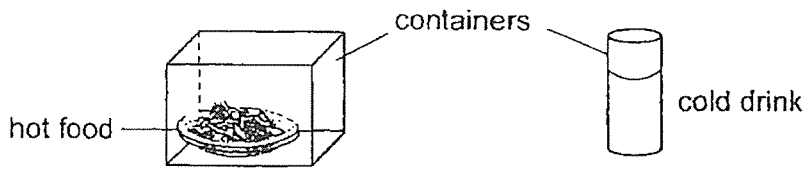

- (b) Based on the results, which material, aluminium foil, plastic sheet or cloth, should he use to wrap the containers? [1]

	Material to wrap container
for keeping hot food	(i)
for keeping cold drink	(ii)

- (c) Explain your answer in (b)(i). [2]

---

---

---

End of Booklet B

SCORE	3
-------	---



SCHOOL : CATHOLIC HIGH SCHOOL  
 LEVEL : PRIMARY 4  
 SUBJECT : SCIENCE  
 TERM : 2023 SA2

**SECTION A**

Q 1	Q2	Q3	Q4	Q5	Q6	Q7	Q8	Q9	Q10
3	2	3	4	4	4	1	2	2	1
Q 11	Q12	Q13	Q14	Q15	Q16	Q17	Q18	Q19	Q20
4	1	2	2	3	1	3	4	3	1
Q 21	Q22	Q23	Q24	Q25	Q26	Q27	Q28		
1	3	2	4	4	3	1	2		

**SECTION B**

Q29)	K: Flowering plants L: Fungi
Q30)	a) The stem of plant C is thinner than the stem of plant D b) Part E helps plant make food in the light
Q31)	a) The cover is a solid b) Juice is a liquid
Q32)	a) The iron rod moves towards the magnet which exerts a pull on the iron rod b) Puyanesh's observation shows that the iron is a magnetic material
Q33)	a) The light from the lamp is reflected by the ball and enters Lucian's eye b) Z. Z is best at reflecting light so when the driver shines his light he could see the cyclist clearly. c) Light sensor connected to datalogger.
Q34)	a) Flexibility. The ability to bend without breaking b) The more mass added, the distance d decreases c) The distance d decreases more than when the same mass were used, because the strip made of material A is more flexible
Q35)	a) G, J, L b) It absorbs water from the undigested food into the bloodstream c) The gullet does not digest any food

	d) Digestion ends at the small intestine												
Q36)	<p>a) The iron rod would attract the paper clip</p> <p>b) The iron rod had become a electromagnet so it can attract the paper clips</p> <p>c) The iron rod would not attract the wooden toothpick</p> <p>d) The iron rod would not attract any paper clips because it has lost its magnetism.</p>												
Q37)	<p>a) A and C both lay eggs in water</p> <p>b) B has a three stage life cycle but D has a four stage life cycle.</p> <p>c) (i) frog: A (ii) butterfly: D</p>												
Q38)	<p>a) Air is occupying the space the water once occupied and pushed the water out</p> <p>b) The water level in the cup would increase as the air would escape through the hole, letting water occupy the space.</p>												
Q39)	<p>a) If the distance of the object from the light source affects the length of the shadow.</p> <p>b) Light travels in a straight line so when it is blocked, a shadow is formed.</p> <p>c)</p> <table border="1" data-bbox="424 1115 1401 1429"> <thead> <tr> <th>Variables</th> <th>Changed</th> <th>Kept the same</th> </tr> </thead> <tbody> <tr> <td>Type of torch</td> <td></td> <td></td> </tr> <tr> <td>Distance of object from light source</td> <td></td> <td></td> </tr> <tr> <td>Length of shadow</td> <td></td> <td></td> </tr> </tbody> </table>	Variables	Changed	Kept the same	Type of torch			Distance of object from light source			Length of shadow		
Variables	Changed	Kept the same											
Type of torch													
Distance of object from light source													
Length of shadow													
Q40)	<p>a) Heat travelled from the hot sand to the air in the bottle</p> <p>b) Metal is a better conductor of heat so more heat is lost from the metal bottle to the surroundings</p> <p>c) The temperature of the sand would be reduced to 30 degrees as it is room temperature</p>												
Q41)	<p>a) X</p> <p>b) (i) cloth (ii) cloth</p> <p>c) Cloth is a poor conductor of heat and is able to reduce most heat loss from the hot food to the surroundings.</p>												