



**ROSYTH SCHOOL
MID-YEAR EXAMINATION 2022
MATHEMATICS
PRIMARY 6
PAPER 1**

Name: _____ Register No. _____

Class: Pr 6 - _____ Math Teacher: _____

Date: 13 May 2022 Parent's Signature: _____

Total Time for Booklets A and B : 1 hour

BOOKLET A

Instructions to Pupils:

1. Do not turn over this page until you are told to do so.
2. Follow all instructions carefully.
3. Answer all questions.
4. Shade your answers in the Optical Answer Sheet (OAS) provided.
5. You are **not** allowed to use a calculator.

Section	Maximum Mark	Marks Obtained
Paper 1 (Booklet A)	20	

* This booklet consists of 7 pages (including this cover page).

Questions 1 to 10 carry 1 mark each. Questions 11 to 15 carry 2 marks each.
 For each question, four options are given. One of them is the correct answer.
 Make your choice (1, 2, 3 or 4). Shade the oval (1, 2, 3 or 4) on the Optical Answer Sheet.

All diagrams in this paper are not drawn to scale unless stated otherwise.

(20 marks)

1. The number of visitors who visited a tourist attraction is 24 703.
 Round this number to the nearest thousand.

- (1) 20 000
- (2) 24 000
- (3) 24 700
- (4) 25 000

2. Which one of the following has the same value as $6 \div \frac{4}{5}$?

- (1) $\frac{6}{1} \times \frac{5}{4}$
- (2) $\frac{6}{1} \times \frac{4}{5}$
- (3) $\frac{1}{6} \times \frac{5}{4}$
- (4) $\frac{1}{6} \times \frac{4}{5}$

3. Which one of the following shapes has both parallel lines and perpendicular lines?

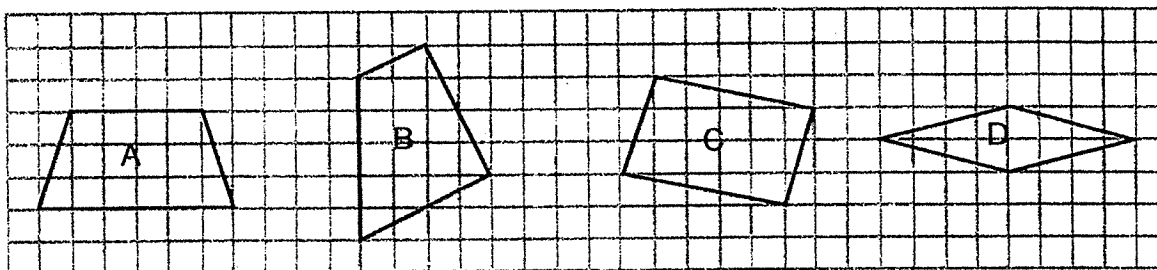

- (1) A
- (2) B
- (3) C
- (4) D

4. Express $9\frac{3}{25}$ as a decimal.
- (1) 9.03
 - (2) 9.12
 - (3) 9.25
 - (4) 9.3
5. Jane, Ken and Ali had an average of 30 stickers in their collection. They were then given 5 stickers each. What was the total number of stickers they had in the end?
- (1) 35
 - (2) 90
 - (3) 95
 - (4) 105
6. Express $20m + 15 - 7m - 10$ in the simplest form.
- (1) $13m - 5$
 - (2) $13m + 5$
 - (3) $13m - 25$
 - (4) $13m + 25$
7. At a carnival, the ratio of the number of adults to the number of children was 7 : 25. The ratio of the number of boys to the number of girls was 3 : 2. What was the ratio of the number of boys to the number of adults?
- (1) 15 : 7
 - (2) 3 : 7
 - (3) 10 : 7
 - (4) 7 : 3

8. In the figure below, PQRS is a trapezium.

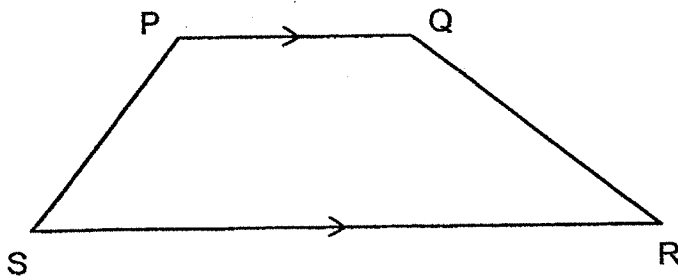

Which of the following statements is true?

- (1) $\angle SPQ = \angle PQR$
 - (2) $\angle RSP = \angle SPQ$
 - (3) $\angle SPQ + \angle PQR = 180^\circ$
 - (4) $\angle PQR + \angle QRS = 180^\circ$
9. The figure below shows a three-quarter circle. The length of OA is 7 cm. Find its perimeter.

(Take $\pi = \frac{22}{7}$)

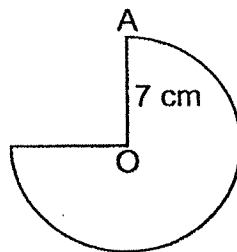

- (1) 33 cm
- (2) 40 cm
- (3) 47 cm
- (4) 154 cm

10. Which one of the following fractions is larger than $\frac{1}{3}$?

(1) $\frac{3}{11}$

(2) $\frac{6}{17}$

(3) $\frac{7}{21}$

(4) $\frac{9}{28}$

11. In the figure, AB, CD and EF are straight lines. $\angle AFD = 135^\circ$ and $\angle BFE = 40^\circ$. Find $\angle a$.

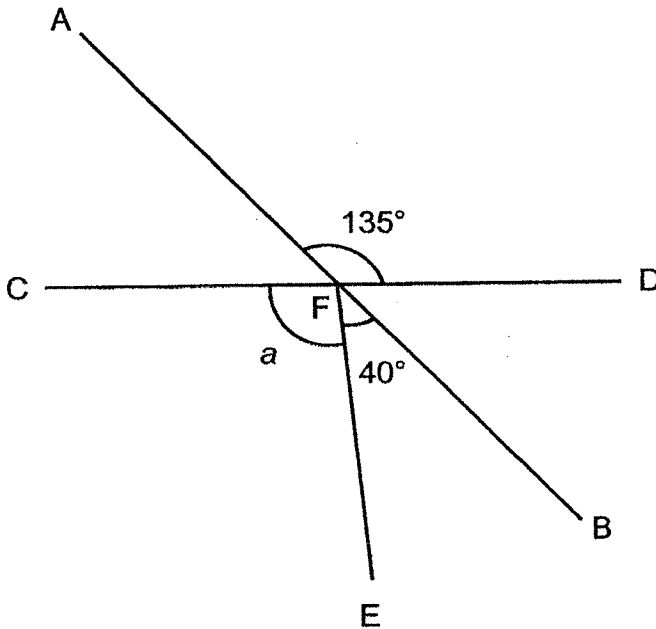

(1) 85°

(2) 90°

(3) 95°

(4) 135°

12. The table below shows how much a shop charges for bicycle rental.

First 2 hours	\$30
Every additional hour or part thereof	\$10

Kenny paid \$70 to rent a bicycle. Which of the following could be the duration he had rented the bicycle for?

- (1) 4.5 h
 - (2) 5.5 h
 - (3) 6.5 h
 - (4) 7.5 h
13. The figure below is made up of a circle and triangle ABC. Line AB passes through the centre of the circle. What is the area of the shaded part?
(Take $\pi = 3.14$)

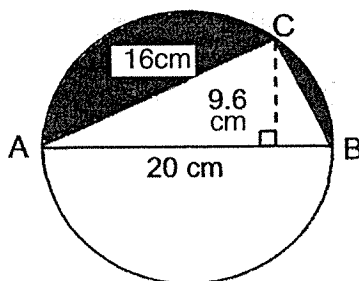

- (1) 61 cm^2
- (2) 96 cm^2
- (3) 218 cm^2
- (4) 410 cm^2

14. Two rectangular tanks are shown below. Both Tank P and Tank R were half-filled with water. Then, all the water from Tank P was poured into Tank R without spilling. What was the height of the water level in Tank R in the end?

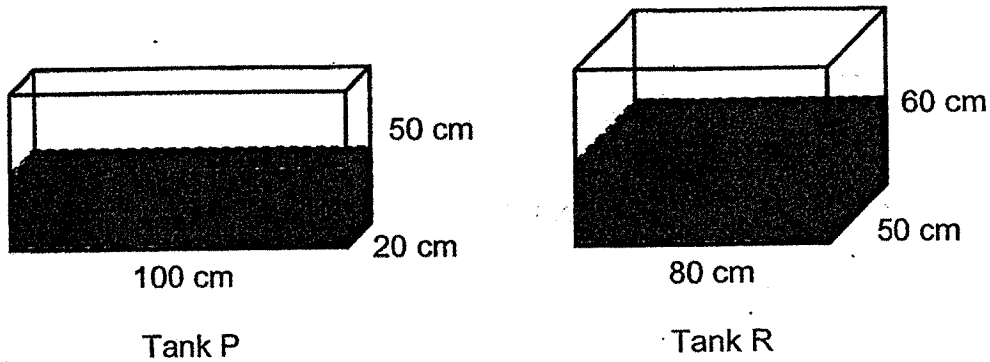

- (1) 12.5 cm
(2) 30 cm
(3) 42.5 cm
(4) 72.5 cm
15. There are red and green apples in a basket. $\frac{2}{5}$ of them are rotten while the rest are not rotten. $\frac{1}{3}$ of the rotten apples are green and $\frac{2}{9}$ of the apples that are not rotten are red. What fraction of the apples are red?
- (1) $\frac{7}{9}$
(2) $\frac{2}{5}$
(3) $\frac{2}{15}$
(4) $\frac{4}{27}$



**ROSYTH SCHOOL
MID-YEAR EXAMINATION 2022
MATHEMATICS
PRIMARY 6
PAPER 1**

Name: _____ Register No. _____

Class: Pr 6 Math Teacher: _____

Date: 13 May 2022 Parent's Signature: _____

Total Time for Booklets A and B : 1 hour

BOOKLET B

Instructions to Pupils:

1. Do not turn over this page until you are told to do so.
2. Follow all instructions carefully.
3. Answer all questions.
4. Use a dark blue or black ballpoint pen to write your answers in the space provided for each question.
5. Do not use correction fluid/tape or highlighters.
6. You are **not** allowed to use a calculator.

Section	Maximum Mark	Marks Obtained
Paper 1 (Booklet B)	25	

* This booklet consists of **9** pages (including this cover page).
This paper is not to be reproduced in part or whole without the permission of the Principal.

Questions 16 to 20 carry 1 mark each. Write your answers in the spaces provided. For questions which require units, give your answers in the units stated.

Do not write in this space

All diagrams in this paper are not drawn to scale unless stated otherwise.
(5 marks)

16. Find the value of 0.36×4000 .

Ans: _____

17. The figure below is made up of identical squares. With AB as the line of symmetry, shade the least number of squares to complete the symmetric figure.

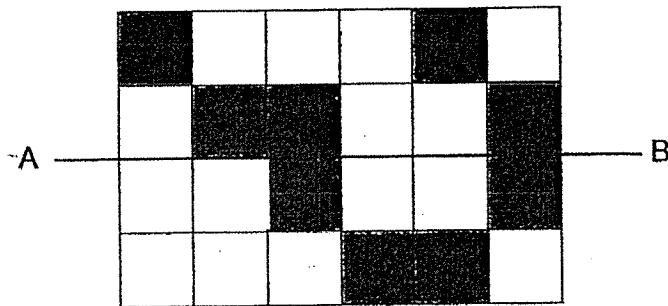

18. Find the value of $1\frac{5}{6} + \frac{1}{8}$
Express your answer as a mixed number in the simplest form.

Ans: _____

19. Mdm Neo paid \$75 for a cupboard after a discount of 40%. What was the price of the cupboard before the discount?

Do not write in this space

Ans: \$ _____

20. Study the diagram below.
 Nine landmarks on a street directory are shown in the square grid below.

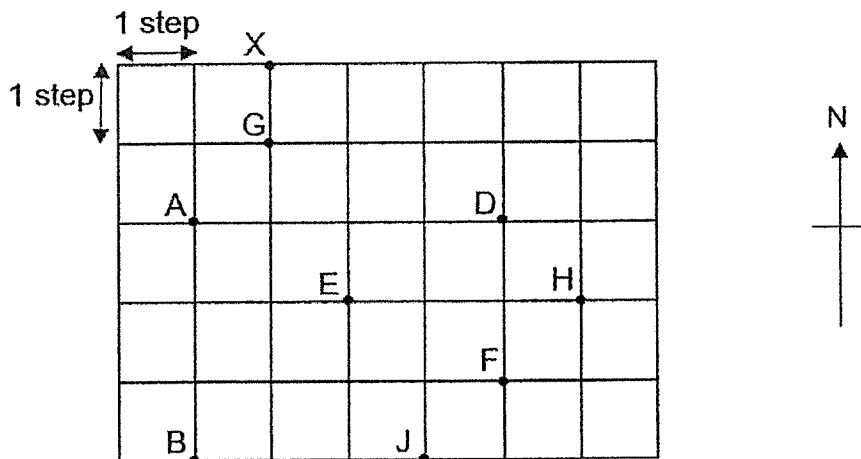

Adam was at one of the landmarks. He was facing South-west.
 He turned 90° anti-clockwise and faced F.
 At which landmark was Adam at?

Ans: _____

Questions 21 to 30 carry 2 marks each. Show your workings clearly in the space provided for each question and write your answers in the spaces provided. For questions which require units, give your answers in the units stated. Do not write in this space

All diagrams in this paper are not drawn to scale unless stated otherwise.
(20 marks)

21. The figure is made up of two semicircles and a rectangle. The length of the rectangle is 21 cm and its breadth is 14 cm. What is the perimeter of the figure?

(Take $\pi = \frac{22}{7}$)

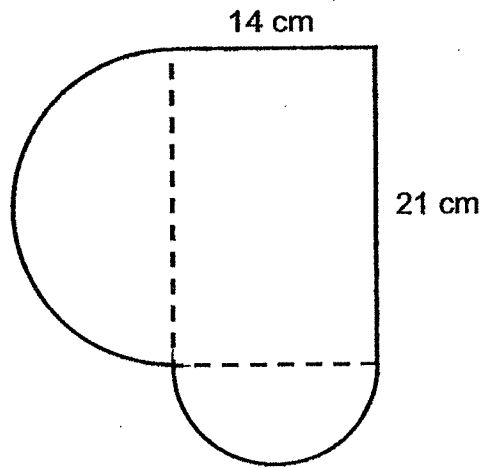

Ans: _____ cm

22. The graphs below show the type of stationery sold at a bookshop over two weeks. The number of each type of stationery sold was not shown. Both graphs are drawn based on the same scales.

Do not write
in this space

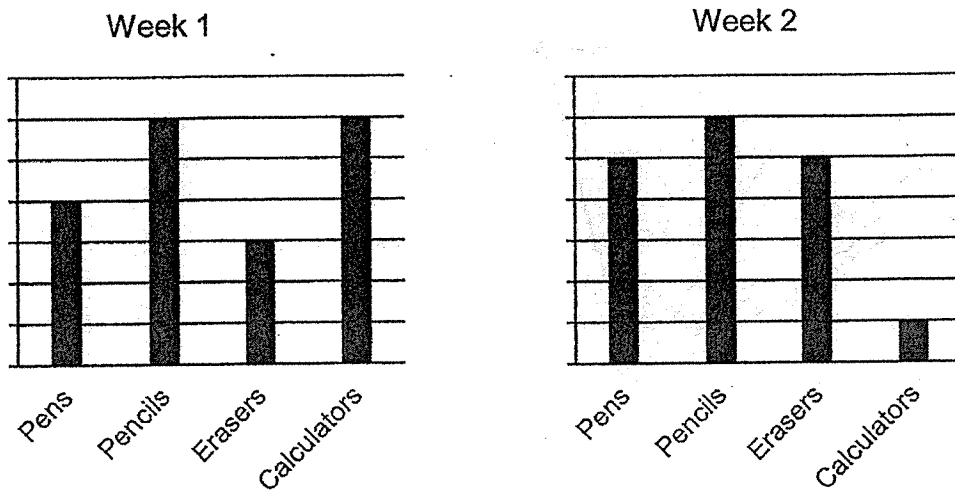

- (a) Which type of stationery had the greatest increase in sales from Week 1 to Week 2?

Ans: (a) _____

- (b) What was the percentage increase in part (a)?

Ans: (b) _____ %

23. Find the value of $5w + 10 - \frac{4w}{3}$ when $w = 9$.

Ans: _____

24. The diagram below shows a rectangular piece of paper ABCD. The paper is folded as shown below. Find $\angle y$.

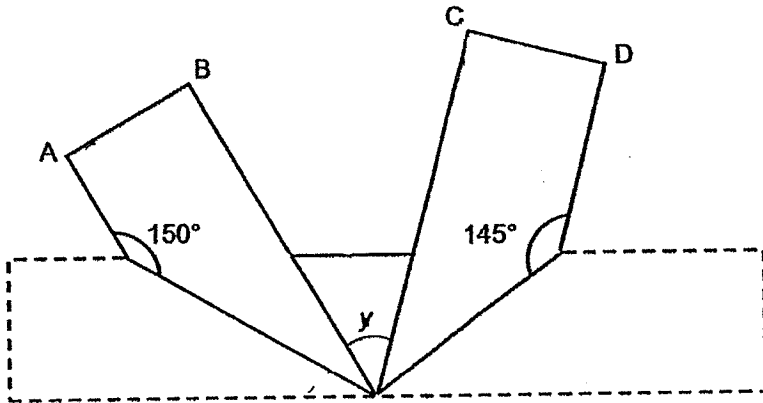

Do not write in this space

Ans: _____ °

25. The ratio of Raju's savings to Weiming's savings was 4 : 5 at first. After they each donated \$110 to charity, the ratio of Raju's savings to Weiming's savings became 5 : 9. What was Raju's savings at first?

Ans: \$ _____

26. The solid below is made up of 10 cubes.

Do not write
in this space

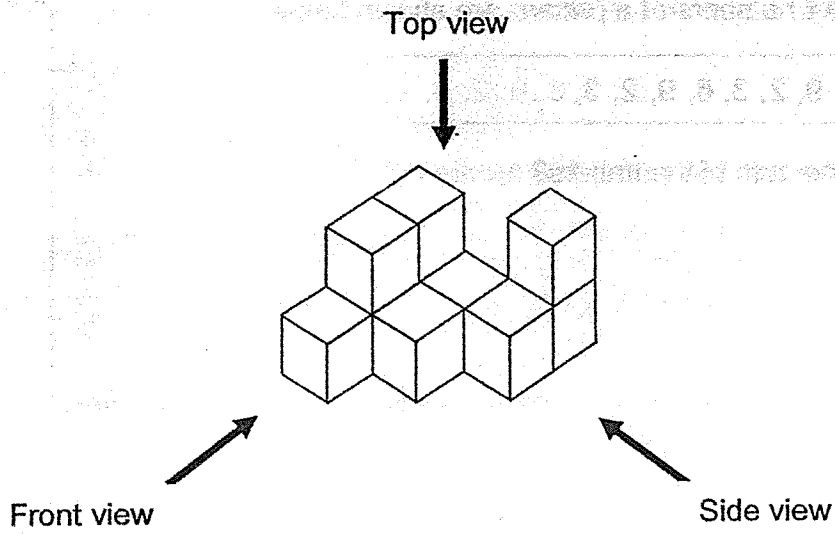

(a) Draw the front view of the solid on the grid below.

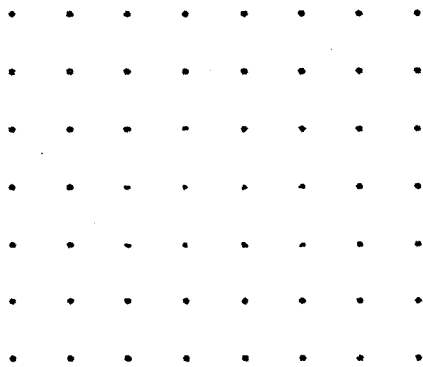

(b) Draw the top view of the solid on the grid below.

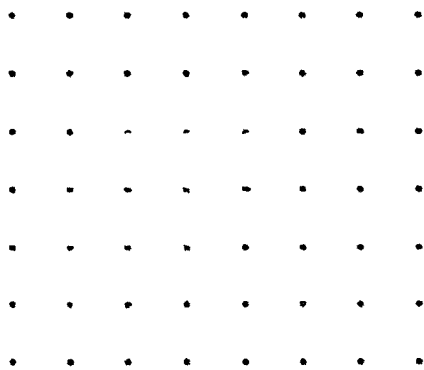

Do not write
in this space

27. The first 14 numbers of a pattern are shown below.

2, 3, 6, 9, 2, 3, 6, 9, 2, 3, 6, 9, 2, 3, ...

What is the sum of the first 158 numbers?

Ans: _____

28. Andrew had \$3.60 more than Brenda. If Brenda gave Andrew \$2.10, Andrew would have thrice as much money as Brenda. How much money did Brenda have?

Ans: \$ _____

Do not write
in this space

29. Colin had just enough money to buy either 8 comic books and 8 magazines or 9 comic books and 6 magazines. If he used all his money to buy comic books only, how many comic books could he buy?

Ans: _____

30. The table shows how much Peter earned for each hour of work at a cafe.

Monday to Friday	\$7 per hour
Saturday and Sunday	\$10 per hour

Each of the statements is either true, false or not possible to tell from the information given. For each statement, put a tick (✓) to indicate your answer.

Statement	True	False	Not possible to tell
Peter had to work for at least 8 hours to earn \$60 on a weekday.			
Peter would have earned \$550 in a week if he had worked 10 hours each day.			

End of paper
Have you checked your work?



**ROSYTH SCHOOL
MID-YEAR EXAMINATION 2022
MATHEMATICS
PRIMARY 6
PAPER 2**

Name: _____ Register No. _____

Class: Pr 6 - _____ Math Teacher: _____

Date: 13 May 2022 Parent's Signature: _____

Time: 1h 30min

Instructions to Pupils:

1. Do not turn over this page until you are told to do so.
2. Follow all instructions carefully.
3. Answer all questions.
4. Use a dark blue or black ballpoint pen to write your answers in the space provided for each question.
5. Do not use correction fluid/tape or highlighters.
6. The use of an approved calculator is allowed.

Questions	Maximum Mark	Marks Obtained
Q 1 to 5	10	
Q 6 to 17	45	

Section	Maximum Mark	Marks Obtained
Paper 1	45	
Paper 2	55	
Total	100	

* This booklet consists of 17 pages (including this cover page)

Questions 1 to 5 carry 2 marks each. Show your working clearly in the space provided for each question and write your answers in the spaces provided. For questions which require units, give your answers in the units stated.

(10 marks)

Do not write in this space

All diagrams in this paper are not drawn to scale unless stated otherwise.

1. The figure shows 3 identical rectangles placed together. Each rectangle is 1 m by 3.2 m. What is the perimeter of the figure?

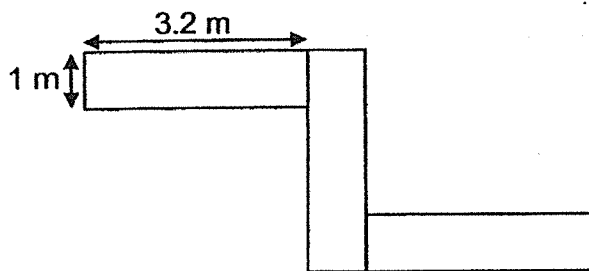

Ans: _____ m

2. The children at a camp were divided equally into Group A and Group B. The ratio of the number of boys to the number of girls in Group A was 2 : 3. The ratio of the number of boys to the number of girls in Group B was 4 : 3. What was the ratio of the number of boys to the number of girls at the camp?

Ans: _____

3. A pet shop opens every day for the time shown in the table below.

Do not write
in this space

Opening hours
8.30 a.m. to 12.00 p.m.
2 p.m. to 4.30 p.m.
6.45 p.m. to 10.00 p.m.

How many hours and minutes is the shop open each day?

Ans: _____ h _____ min

4. 3 apples costs \$ h and a mango costs \$1.50. Mdm Lim spent \$16 on 15 apples and 4 mangoes. What is the cost of 3 apples?

Ans: \$ _____

5. There were 8 workers working on 8 machines on Monday. They worked for 8 hours each to produce 10 000 rulers. On Tuesday, 2 of the machines broke down. The 8 workers took turns working on the remaining machines. On average, how many hours would each of them have to work on the remaining machines to produce the same number of rulers?

Do not write
in this space

Ans: _____ h

For Questions 6 to 17, show your working clearly in the space provided for each question and write your answers in the spaces provided. The number of marks available is shown in brackets [] at the end of each question or part-question. For questions which require units, give your answers in the units stated.

Do not write in this space

All diagrams in this paper are not drawn to scale unless stated otherwise.
(45 marks)

6. In the square grid below, BC and CD are straight lines. BC and CD form two sides of a parallelogram ABCD.

(a) Complete the drawing of parallelogram ABCD on the square grid below. Label point A.

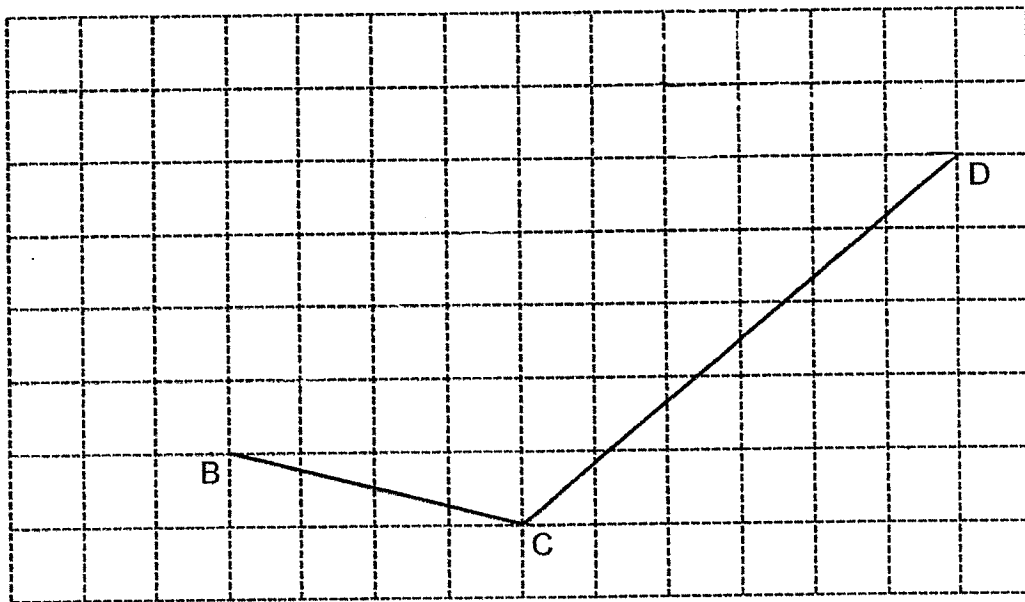

[2m]

(b) Measure $\angle BCD$

Ans: _____ [1m]

7. A group of children was asked to choose an activity from Cycling, Singing and Dancing. 70% of them chose Cycling. The percentage of children who chose Dancing was 20% of the children who chose Singing.

Do not write in this space

(a) The pie chart below represents the number of children who chose each activity. Label the pie chart by writing **C** for Cycling, **S** for Singing and **D** for Dancing in the boxes below.

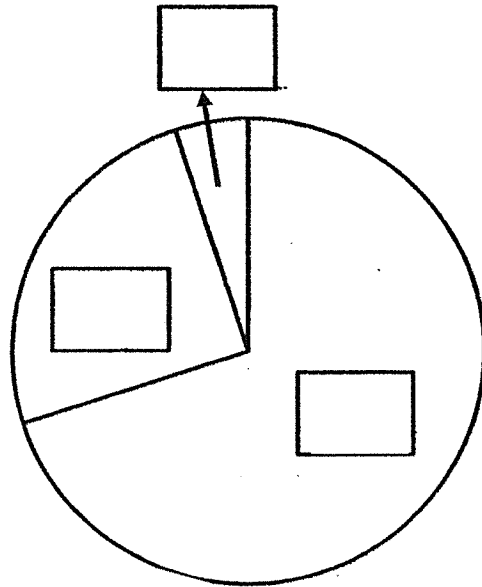

[1m]

(b) There were 60 children who chose Dancing. What was the total number of children in the group?

Ans: _____ [2m]

8. The table below shows the different prices of the tickets for two categories in a sports competition. The ratio of the number of tickets sold for Category A to the number of tickets sold for Category B was 5 : 3. The amount of money collected from the sale of all the tickets was \$19 040. How many children and adults took part in the sports competition altogether?

Do not write
in this space

Category	Cost (\$)
A (1 adult and 1 child)	\$10
B (1 child)	\$6

Ans: _____ [3m]

9. Samantha had a container filled with 4 ℓ of water. She used $\frac{3}{8}$ of the water for washing and $\frac{2}{3}$ ℓ of water for planting. She then poured in additional water into the container such that the amount of water left became twice as much as the amount of water she had at first. How many litres of water did Samantha pour into the container? Express your answer as a mixed number in the simplest form.

Do not write
in this space

Ans: _____ [3m]

10. The graph shows the number of boxes of muffins sold by Mrs Lim from January to April.

Do not write
in this space

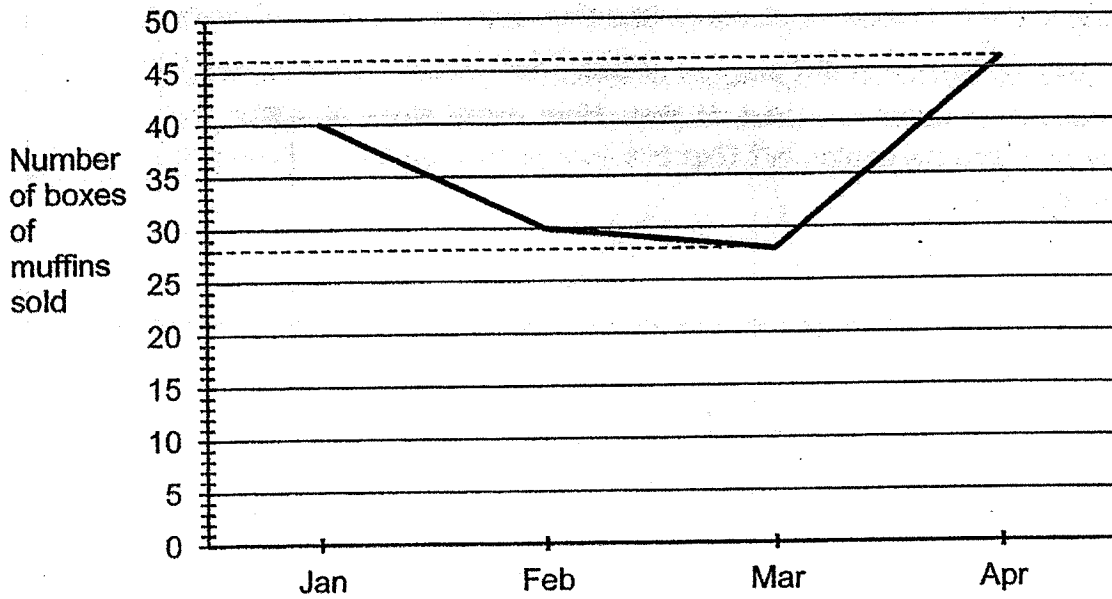

Each box of muffins cost \$25. The total amount of money collected from the sale of muffins from January to May was \$4625. How many boxes of muffins did she sell in May?

Ans: _____ [3m]

11. In the figure, ABCD is a square, AEG is an equilateral triangle and $\angle EAB = 253^\circ$.

Do not write
in this space

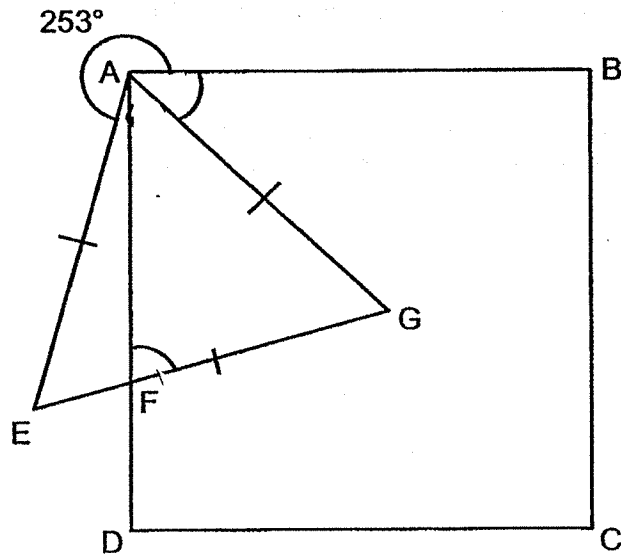

- (a) Find $\angle BAG$.

(a) Ans: _____ [2m]

- (b) Find $\angle AFG$.

(b) Ans: _____ [2m]

Do not write
in this space

12. Andy used $\frac{3}{4}$ of his red ice-cream sticks, $\frac{2}{5}$ of his yellow ice-cream sticks and $\frac{3}{8}$ of his blue ice-cream sticks to make a toy plane. He used an equal number of ice-cream sticks of each colour to make the toy plane.

(a) What fraction of all his coloured ice-cream sticks did he use to make the toy plane? Express your answer in the simplest form.

(a) Ans: _____ [2m]

(b) Andy had 434 coloured ice-cream sticks left, how many coloured ice-cream sticks did he have in all?

(b) Ans: _____ [2m]

13. A rectangular tank with a tap as shown was $\frac{7}{8}$ filled with water at first. The tap was turned on for 4 hours. Water flowed out from the tank to fill 288 bottles. Each bottle was filled completely with 500 ml of water.

Do not write
in this space

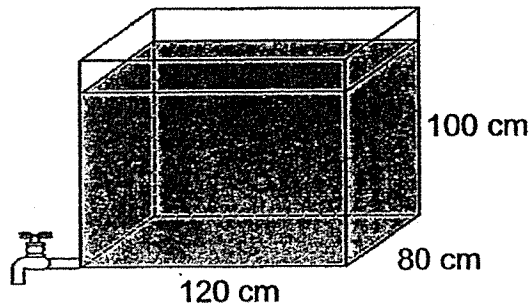

- (a) How much water flowed out of the tap per minute?

(a) Ans: _____ [2m]

- (b) After 4 hours, the tap was turned off. How much more water must be added to the tank to fill it to the brim?

(b) Ans: _____ [2m]

14. In the figure, PQRU is a trapezium. PQ is parallel to UR. QRS is an isosceles triangle. $QR = SR$. $\angle QTU = 147^\circ$, $\angle PTS = 116^\circ$ and $\angle QRS = 32^\circ$.

Do not write in this space

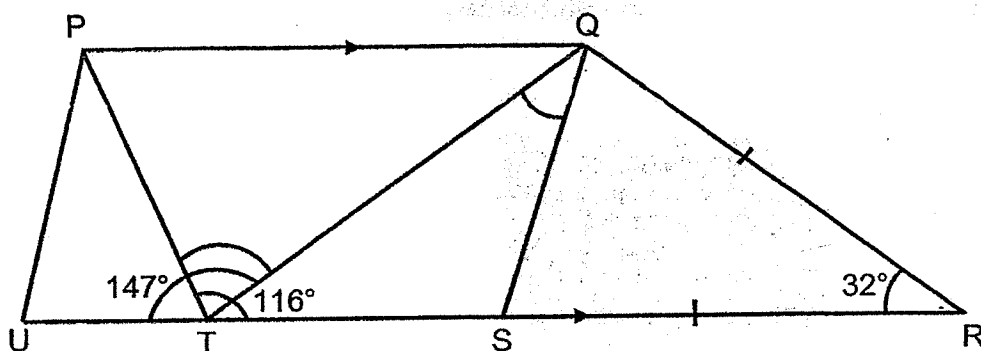

- (a) Find $\angle PTQ$

(a) Ans: _____ [2m]

- (b) Find $\angle TQS$

(b) Ans: _____ [2m]

15. On Saturday, there were 620 more girls than boys at the zoo. On Sunday, the number of boys increased by 28% but the number of girls decreased by 10%. In the end, there were 2862 more boys than girls. What was the total number of boys and girls at the zoo on Sunday?

Do not write
in this space

Ans: _____ [4m]

16. The diagram below shows the seating arrangement in a hall. The shaded squares represent the spaces between the seats. The rest of the seats follow the same pattern and all seats are numbered consecutively.

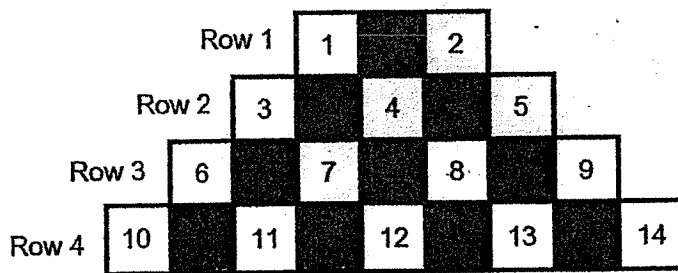

Do not write
in this space

- (a) How many seats are there in Row 8?

(a) Ans: _____ [1m]

- (b) The first seat in Row 4 is numbered 10 and the last seat in Row 4 is numbered 14. In which row is the 25th seat?

(b) Ans: _____ [1m]

- (c) If Mandy is at the 100th seat, what will the last seat in the row she is seated at be numbered?

(c) Ans: _____ [3m]

17. The figure shown below is made up of a rectangle ABCD and four identical three-quarter circles. The area of rectangle ABCD is 294 cm^2 . Do not write in this space

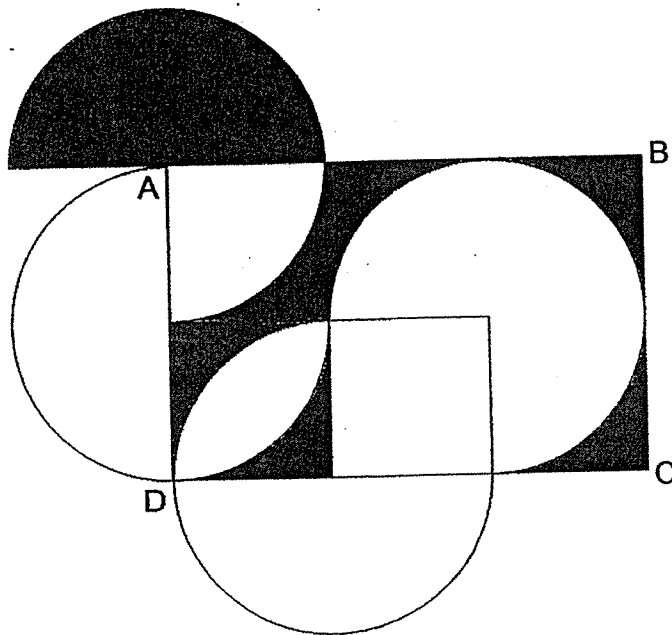

- (a) What is the radius of each three-quarter circle?

(a) Ans: _____ [2m]

Continue part (b) on the next page.



17. (b) What is the ^{total} area of the shaded part?
(Take $\pi = \frac{22}{7}$)

Do not write
in this space

(b) Ans: _____ [3m]

End of Paper
Have you checked your work?

YEAR : 2022
 LEVEL : PRIMARY 6
 SCHOOL : ROYSTH SCHOOL
 SUBJECT : MATHEMATICS
 TERM. : MID-YEAR EXAMINATION

PAPER 1 (BOOKLET A)

Q1	4	Q2	1	Q3	2	Q4	2	Q5	4
Q6	2	Q7	1	Q8	4	Q9	3	Q10	2
Q11	3	Q12	2	Q13	1	Q14	3	Q15	2

(BOOKLET B)

Q16	1440				
Q17					
Q18	$1\frac{23}{24}$				
Q19	\$125				
Q20	G				
Q21	$\frac{1}{2} \times \frac{22}{7} \times 14$ $= 22$ $\frac{1}{2} \times \frac{22}{7} \times 21$ $= 33$ $21 + 14 + 33 + 22$ $= 90 \text{ cm}$				
Q22	<table border="1"> <tr> <td>(a)</td> <td>Erasers</td> </tr> <tr> <td>(b)</td> <td> $\frac{2u}{3u} = 100\% = \frac{200\%}{3}$ $= 66.7\%$ </td> </tr> </table>	(a)	Erasers	(b)	$\frac{2u}{3u} = 100\% = \frac{200\%}{3}$ $= 66.7\%$
(a)	Erasers				
(b)	$\frac{2u}{3u} = 100\% = \frac{200\%}{3}$ $= 66.7\%$				
Q23	$(5 \times 9) + 10 - \frac{4 \times 9}{3}$ $= 45 + 10 - \frac{36}{3}$ $= 55 - 12$ $= 43$				
Q24	50°				
Q25	$11u : 110$ $1u : 10$ $16u : \$160$ \$160				

Q26	(a)			
	(b)			
Q27	<p>No. of gp : $158 \div 20 = 39R2$ $39 \times 20 = 780$ $780 + 2 + 3$ $= 785$</p>			
Q28	<p>2u : $2.10 + 3.60 + 2.10$ $= 7.80$ 1u : $7.80 \div 2$ $= 3.90$ $3.90 + 2.10$ $= \\$6$</p>			
Q29	<p>8 comics & 8 magazines 9 comics & 6 magazines 2 comics = 1 magazines Ans: 12</p>			
Q30	True	False	Not possible to tell	
		✓		
	✓			

YEAR : 2022
LEVEL : PRIMARY 6
SCHOOL : ROYSTH SCHOOL
SUBJECT : MATHEMATICS
TERM. : MID-YEAR EXAMINATION

(PAPER 2)

Q1	$1 + 3.2 + 1 + 1 + 3.2$ $= 10.4$ $3.2 - 1$ $= 2.2$ $2.2 + 2.2 + 3.2 + 3.2$ $= 10.8$ $10.8 + 10.4$ $= 21.2\text{m}$
Q2	$B : G : T$ $2 : 3 : 5$ $14 : 21 : 35$ $B : G : T$ $4 : 3 : 7$ $20 : 15 : 35$ $B : G$ $34 : 36$
Q3	$3.15 + 2.30 + 3.30$ $= 8.75$ Ans: 9h 15 min
Q4	15 apple : 5h 4×1.50 $= 6$ $6 + 5\text{h}$ $= 16$ $5\text{h} = 10$ $H = 10 \div 5$ $= \$2$
Q5	8×8 $= 64$ $64 \div 6$ $= 10 \frac{2}{3}\text{h}$

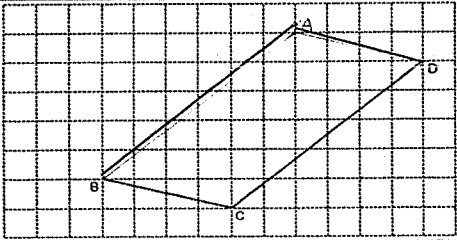
Q6	(a)	
	(b)	126°

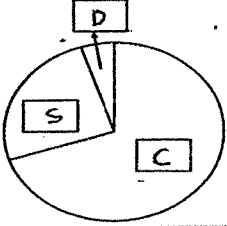
Q7	(a)	
	(b)	$D : S$ $20 : 100$ $1 : 5$ $5 + 1 = 6$ 60×6 $= 360$ $360 \div 3$ $= 120$ 120×10 $= 1200$

Q8	$A : B$ $5 : 3$ $(10 \times 5) + (6 \times 3)$ $= 68$ $19040 \div 68$ $= 280$ 280×13 $= 3640$
----	---

Q9	$\frac{3}{8} \times 4$ $= \frac{3}{2}$ $4 - \frac{3}{2} - \frac{2}{3}$ $= 1 \frac{5}{6}$ $8 - 1 \frac{5}{6}$ $= 6 \frac{1}{6} \text{ L}$
----	---

Q10	$40 + 30 + 28 + 46$ $= 144$ 144×25 $= 3600$ $4625 - 3600$ $4625 - 3600$ $= 1025$ $1025 \div 25 = 41$
-----	--

Q11	(a)	$360 - 60 - 253$ $= 47^\circ$
	(b)	$180 - 60 - 43$ $= 77^\circ$
Q12	(a)	R Y B $\frac{3}{4} \quad \frac{2}{5} \quad \frac{3}{8}$ $\frac{6}{8} \quad \frac{6}{15} \quad \frac{6}{16}$ $8 + 15 + 16$ $= 39$ $\frac{18}{39} = \frac{6}{13}$
	(b)	$39 - 18$ $= 21$ $\frac{434}{21} \times 39$ $= 806$
Q13	(a)	$\frac{7}{8} \times 120 \times 80 \times 100$ $= 840000$ 288×500 $= 144000$ $840000 - 144000$ $= 696000$ $4 \times 60 = 240$ $4000 - 240$ $= 600\text{ml}$
	(b)	$120 \times 80 \times 100$ $= 960000$ $960000 - 969000$ $= 264000\text{ml}$

Q14	(a)	$180 - 147$ $= 33$ $180 - 116 = 64$ $180 - 64 - 33$ $= 83^\circ$
	(b)	$180 - 33 - 106$ $= 41^\circ$
Q15		$128 - 90u - 558 = 2862$ $38u = 2862 + 558$ $= 3420$ $3420 \div 38$ $= 90$ $218u : 90 \times 218$ $= 19620$ $19620 + 558$ $= 20178$

Q16	(a)	9
	(b)	6
	(c)	$27 + 8 + 9 + 10 + 11 + 12 + 13 + 14$ $= 104$
Q17	(a)	$294 \div 6 = 49$ $\sqrt{49} = 7 \text{ cm}$
	(b)	$14 \times 14 = 196$ $\frac{22}{7} \times 7 \times 7$ $= 154$ $196 - 154$ $= 42$ $\frac{1}{2} \times \frac{22}{7} \times 7 \times 7$ $= 77$ 14×7 $= 98$ $98 - 77 = 21$ $77 + 21 + 42$ $= 140 \text{ cm}$

6

END