

METHODIST GIRLS' SCHOOL (PRIMARY)

Founded in 1887



MID YEAR EXAMINATION 2022 PRIMARY 6 MATHEMATICS

PAPER 1 BOOKLET A

Total Time for Booklets A and B: 1 hour

INSTRUCTIONS TO CANDIDATES

Do not turn over this page until you are told to do so.

Follow all instructions carefully.

Answer all questions.

Shade your answers in the Optical Answer Sheet (OAS) provided.

The use of calculators is **NOT** allowed.

Name: _____ ()

Class: Primary 6. _____

Date: 12 May 2022

This booklet consists of 7 printed pages including this page.

Questions 1 to 10 carry 1 mark each. Questions 11 to 15 carry 2 marks each. For each question, four options are given. One of them is the correct answer. Make your choice (1, 2, 3 or 4). Shade the correct oval (1, 2, 3 or 4) on the Optical Answer Sheet. (20 marks)

1 2 hundred thousands + 9 thousands + 2 hundreds + 2 ones = _____

- (1) 20 922
- (2) 29 202
- (3) 200 922
- (4) 209 202

2 Find the value of $742.5 \div 7$. Round your answer to 1 decimal place.

- (1) 106.0
- (2) 106.1
- (3) 160.0
- (4) 160.1

3 Express 40 cm as a fraction of 2 m.

- (1) $\frac{1}{5}$
- (2) $\frac{1}{20}$
- (3) $\frac{1}{50}$
- (4) $\frac{1}{200}$

4 Find the value of $\frac{3}{4} \div \frac{1}{12}$.

(1) $\frac{1}{16}$

(2) $\frac{1}{9}$

(3) 9

(4) 16

5 A machine can print 70 cards in 3 minutes.
At this rate, how many cards can it print in 1 hour?

(1) 210

(2) 1400

(3) 2100

(4) 4200

6 Find the area of the triangle shown below.

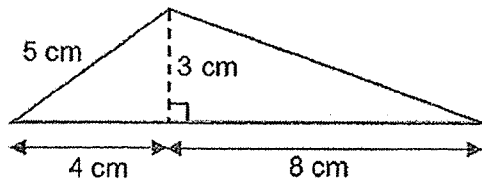

(1) 12 cm^2

(2) 18 cm^2

(3) 20 cm^2

(4) 30 cm^2

- 7 ABCD is a square. QT and BD are straight lines.

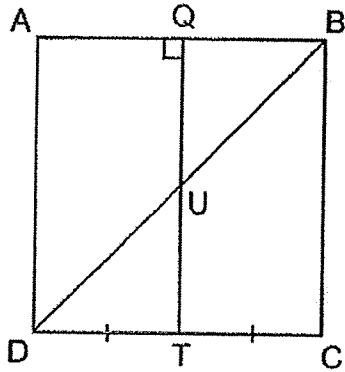

Which of the following is not true?

- (1) $QT \parallel BC$
- (2) $QT \perp DC$
- (3) $\angle DUT = \angle UDT$
- (4) $\angle ADU + \angle QUB = 180^\circ$

- 8 A rectangular container is partially filled with 1-cm cubes as shown below. What is the volume of the container?

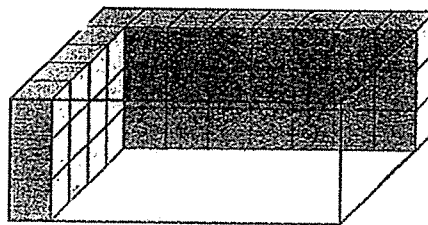

- (1) 84 cm^3
- (2) 96 cm^3
- (3) 105 cm^3
- (4) 120 cm^3

(Go on to the next page)

9

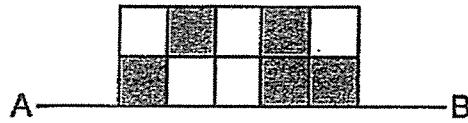

The top half of a symmetric figure is shown above. AB is the line of symmetry. Which one of the following completes the symmetric figure?

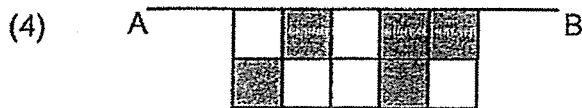
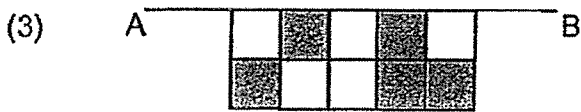
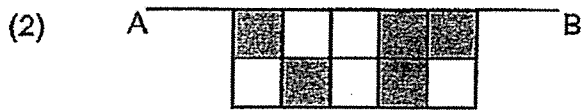
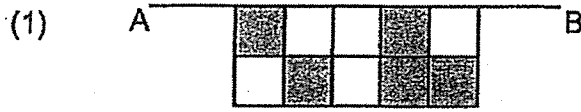

10 Kelly was facing south-west. She turned 315° anti-clockwise. In which direction is she facing now?

- (1) North
- (2) South
- (3) East
- (4) West



11 Using all the digits 2, 5, 7 and 8, form the largest multiple of 5 between 1000 and 8000.

- (1) 7825
- (2) 7852
- (3) 8725
- (4) 8752

12 Su Fen's score for Mathematics improved from 50 marks to 75 marks.
What was the percentage increase in marks?

- (1) $33\frac{1}{3}\%$
- (2) 50%
- (3) $66\frac{2}{3}\%$
- (4) 150%

13 There are an equal number of students in class 6A and 6B.

The ratio of the number of boys to the number of girls in class 6A is 1 : 2.

The ratio of the number of boys to the number of girls in class 6B is 1 : 3.

Find the ratio of the number of girls in 6A to the total number of students in class 6A and 6B.

- (1) 1 : 3
- (2) 1 : 7
- (3) 2 : 3
- (4) 2 : 7

- 14 The solid below is built using 1-cm cubes and placed into a glass tank.

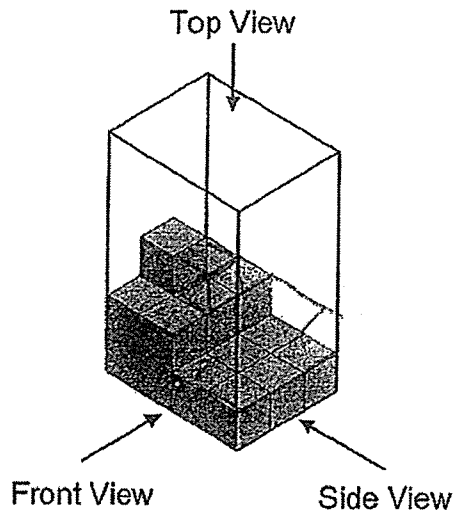

What is the greatest number of cubes that can be added to the solid so that the side view is not changed?

- (1) 8
 (2) 9
 (3) 10
 (4) 14
- 15 Nora and Ming baked some cookies over two days. On Monday, Nora baked 29 cookies more than Ming. On Tuesday, Nora baked another 15 cookies and Ming baked another 20. At the end of the two days, the number of cookies Nora baked was $\frac{3}{5}$ of the total number of cookies baked by the two girls. How many cookies did Nora bake on both days?

- (1) 24
 (2) 36
 (3) 48
 (4) 72

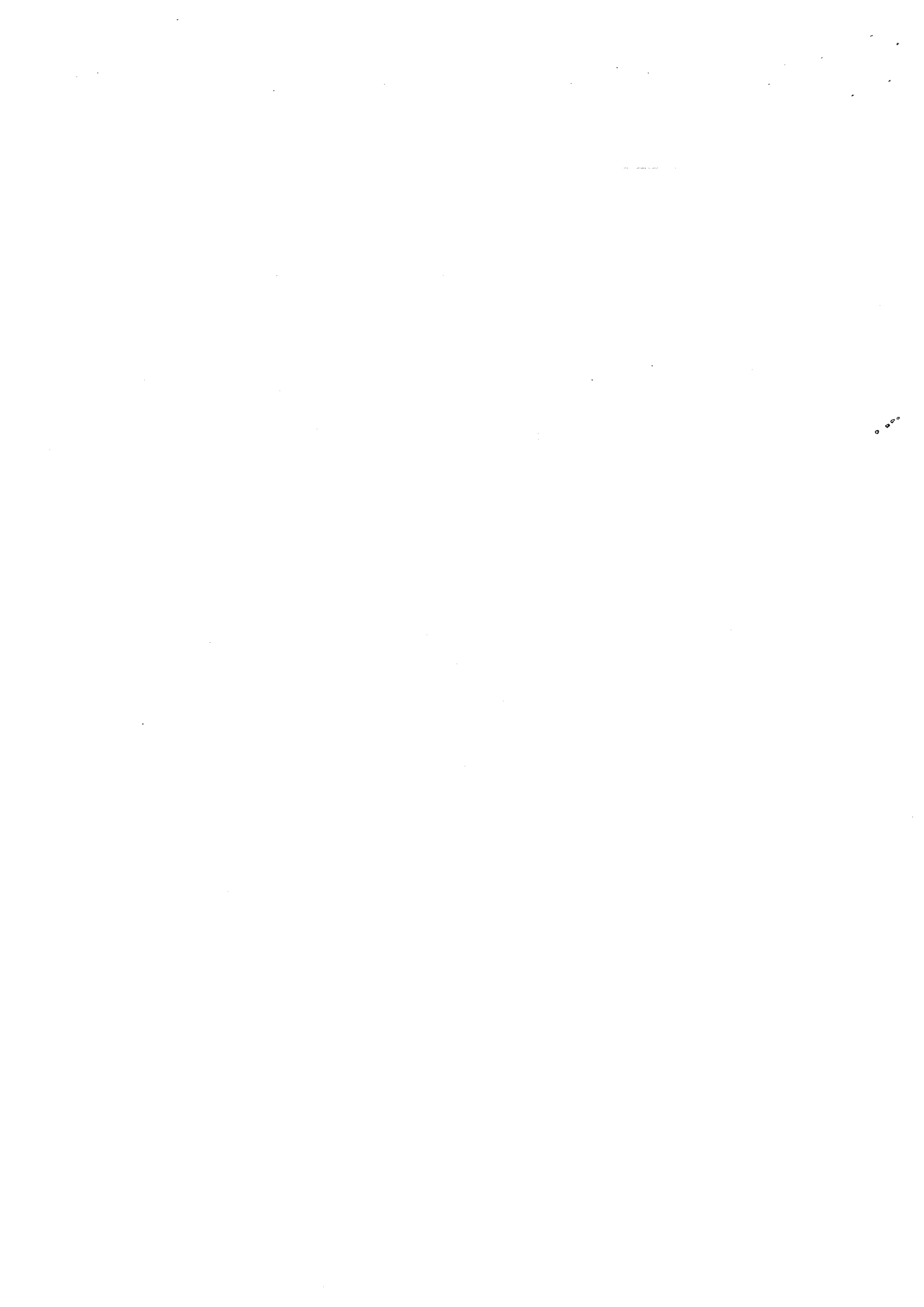

METHODIST GIRLS' SCHOOL (PRIMARY)

Founded in 1887



MID YEAR EXAMINATION 2022 PRIMARY 6 MATHEMATICS

PAPER 1 BOOKLET B

Total Time for Booklets A and B: 1 hour

INSTRUCTIONS TO CANDIDATES

Do not turn over this page until you are told to do so.

Follow all instructions carefully.

Answer all questions.

Write your answers in this booklet.

The use of calculators is **NOT** allowed.

Name: _____ ()

Class: Primary 6. _____

Date: 12 May 2022

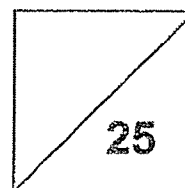

Parent's Signature: _____

This booklet consists of 9 printed pages including this page.

Questions 16 to 20 carry 1 mark each. Write your answers in the spaces provided. For questions which require units, give your answers in the units stated. (5 marks)

Do not write in this space.

16 Christina bought 5 pens at \$2.75 each.

How much did she pay for the pens in total?



Ans: \$ _____

17 The mass of a tennis ball when rounded to the nearest tenth is 58.0 g.

What is the smallest possible mass of the tennis ball?

Ans: _____ g

18 Find the value of $5 \times (38 - 14) + 6 + 27$.

Ans: _____

(Go on to the next page)

19 In the figure, AC and BE are straight lines. Find $\angle EFD$.

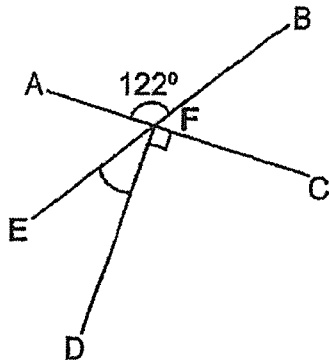

Do not write in this space.

Ans: _____^o



20 In the square grid, WX and XY are two sides of a trapezium WXYZ. The ratio of the length of XW to the length of YZ is 2 : 5 . Complete the trapezium by drawing the other two sides in the grid below.

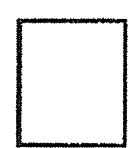
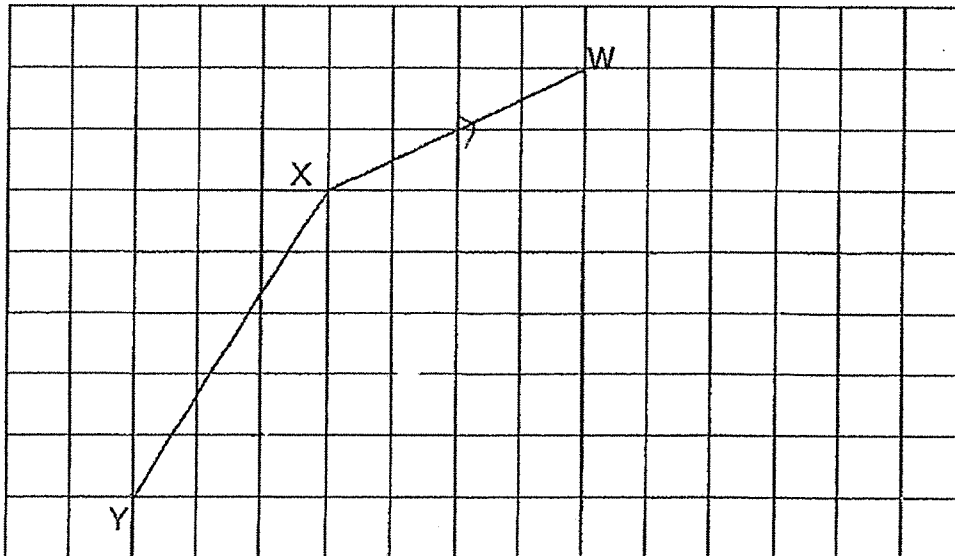

Questions 21 to 30 carry 2 marks each. Show your working clearly and write your answers in the spaces provided. For questions which require units, give your answers in the units stated. (20 marks)

Do not write in this space.

- 21 Muffins are sold in boxes of 1, 4 or 6. Tammy bought 45 muffins.
What is the least number of boxes that Tammy bought?

Ans: _____

- 22 A train left Town A at 10.30 p.m. and reached Town B at 8.25 a.m. the next day. How long did the journey take? Give your answer in hours and minutes.

Ans: _____ h _____ min

(Go on to the next page)

- 23 Mr Wong bought 576 roses. The ratio of the number of red roses to the number of white roses was 3 : 2. The ratio of the number of white roses to the number of pink roses was 1 : 2. How many pink roses did Mr Wong buy?

Do not
write in
this space.

Ans: _____

- 24 A rectangular container measuring 60 cm long, 20 cm wide and 30 cm high is filled with water to a height of 12 cm. How much more water is needed to fill the container completely?

Ans: _____ cm³

(Go on to the next page)

- 25 Karen poured water from Container A to Containers B and C so that the height of the water in the 3 containers became the same.

Find the volume of water left in Container A.

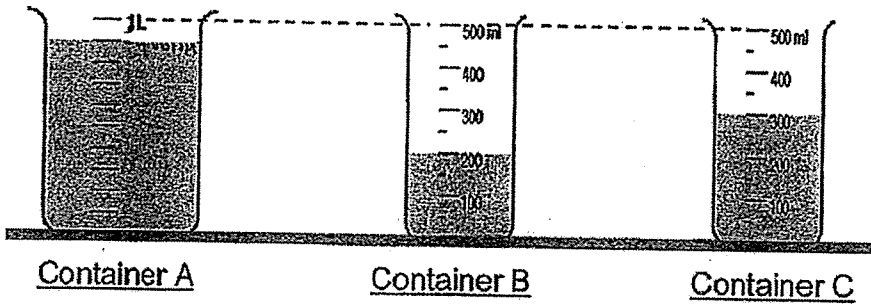

Do not
write in
this space.

Ans: _____ ml



- 26 The pie chart shows the grades A, B, C and D obtained by some pupils in a Mathematics test. $\frac{2}{5}$ of the pupils obtained grade B. What fraction of the pupils obtained grade D?

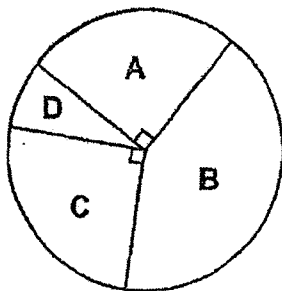

Ans: _____



(Go on to the next page)

- 27 Joyce has a rectangular piece of paper, 8 cm by 14 cm. It is white on one side and coloured on the other side. She folds the paper along the dotted lines as shown below. Express the area of the coloured triangle T as a fraction of the area of the whole piece of paper. Give your answer in the simplest form.

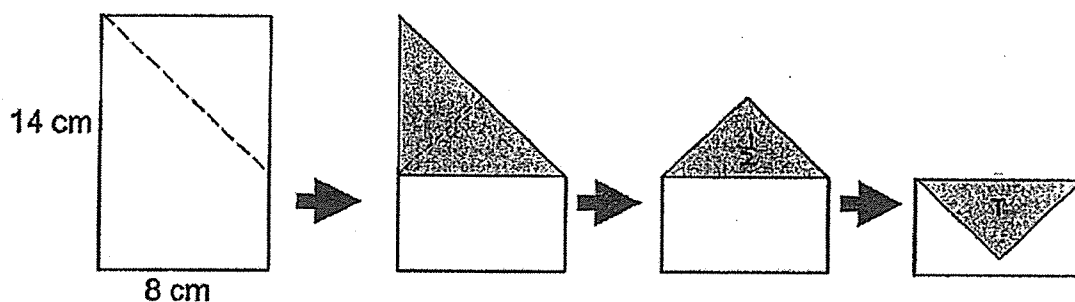

Do not
write in
this space

Ans: _____

- 28 Joanne spent $\frac{1}{4}$ of her money on a watch and $\frac{1}{6}$ of her remaining money on a pair of shoes. She has \$125.50 left. How much did the watch cost?

Ans: \$ _____

(Go on to the next page)

- 29 The bar graph shows the number of cakes sold in a shop from Monday to Friday. Part of the bar graph was accidentally torn off. The average number of cakes sold from Monday to Tuesday was the same as the average number of cakes sold from Wednesday to Friday. What is the total number of cakes sold on Thursday and Friday?

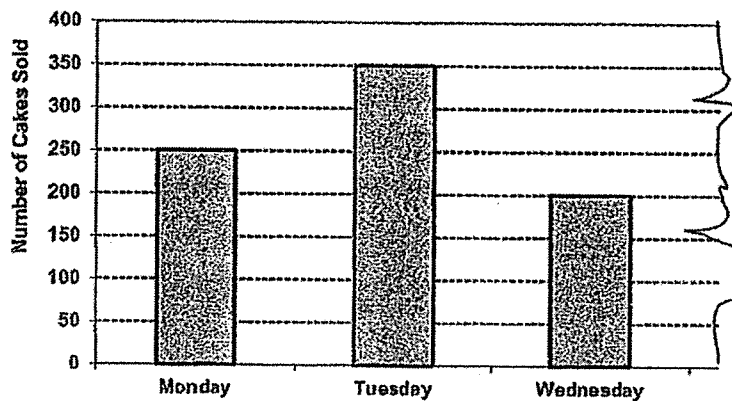

Ans: _____

2

(Go on to the next page)

- 30 The diagram below shows four different triangles ABC, BCD, BCE and BFE.

Do not write in this space.

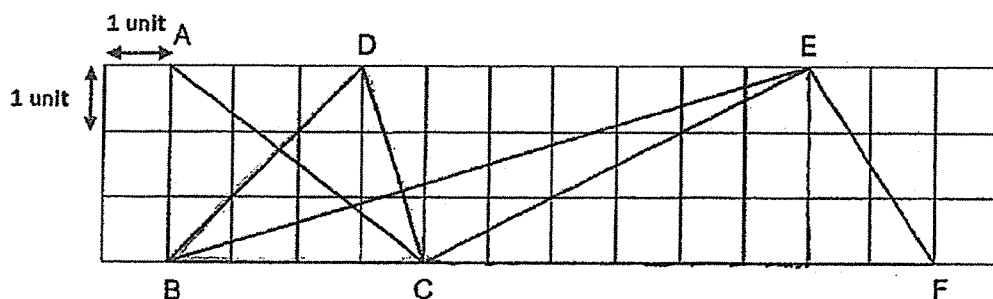

Each statement below is either true, false, or not possible to tell from the information given. For each statement, put a tick (✓) in the correct column.

Statement	True	False	Not possible to tell
(a) The area of ABC is 6 square units.			
(b) Twice the area of BCD is 9 square units.			
(c) The ratio of the area of BCE to the area of BFE is 1 : 3.			

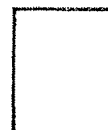

END OF PAPER

0 0 0

METHODIST GIRLS' SCHOOL (PRIMARY)

Founded in 1887



MID YEAR EXAMINATION 2022 PRIMARY 6 MATHEMATICS

PAPER 2

Duration: 1h 30 min

INSTRUCTIONS TO CANDIDATES

Do not turn over this page until you are told to do so.

Follow all instructions carefully.

Answer all questions.

Write your answers in this booklet.

The use of an approved calculator is expected, where appropriate.

Name: _____ ()

Class: Primary 6. _____

Date: 12 May 2022

Parent's Signature: _____

Paper 1 Booklet A	/ 20
Paper 1 Booklet B	/ 25
Paper 2	/ 55
TOTAL	/ 100

This booklet consists of 17 printed pages including this page.

Questions 1 to 5 carry 2 mark each. Show your working clearly and write your answers in the spaces provided. For questions which require units, give your answers in the units stated. (10 marks)

Do not write in this space

- 1 Kristen and Lauren had 85 stickers altogether. After Kristen gave Lauren 18 stickers, she had 21 stickers more than Lauren. How many stickers did Kristen have at first?

Ans: _____

- 2 STUV is a square. SU and VW are straight lines. $\angle VWT = 122^\circ$. Find $\angle t$.

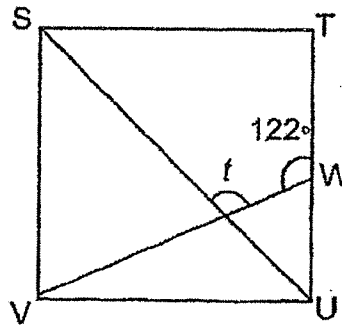

Ans: _____^o

(Go on to the next page)

- 13 ABCD is made up of a triangle X, a rectangle Y and a trapezium Z as shown below. DC is a straight line. Find the area of ABCD.

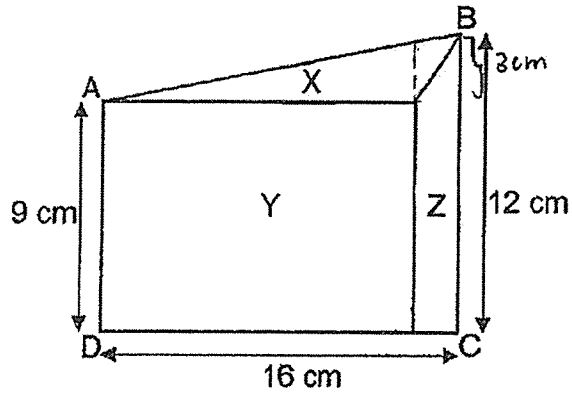

Do not write in this space

Ans: _____ cm²

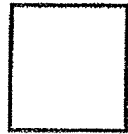

- 4 A rectangular piece of paper was folded along its diagonal BD as shown below. DE = EB. The ratio of the AE : BE : BC is 3 : 5 : 4. Find the ratio of the area of triangle EBD to the area of triangle BCE.

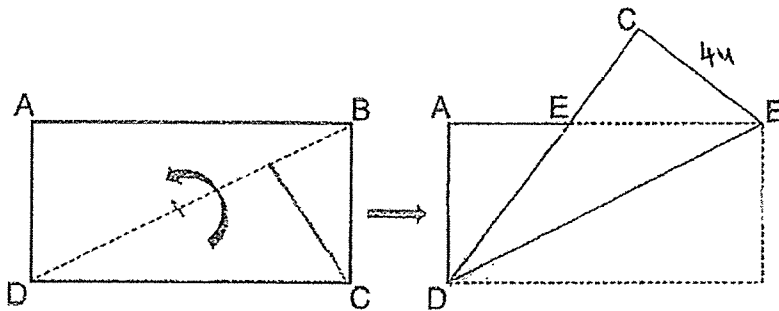

Ans: _____

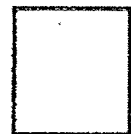

- 5 The graph below shows the types of books borrowed by 80 students.

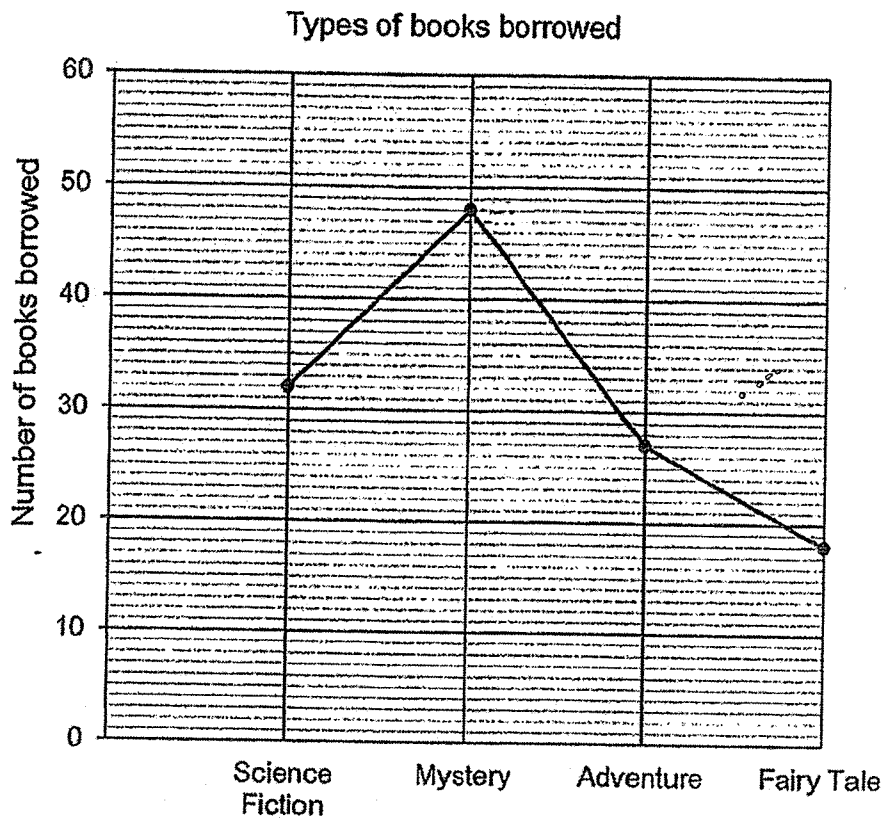

Each student borrowed either 1 or 2 story books.

How many students borrowed 2 books?

Ans: _____

Do not
write in
this space



(Go on to the next page)

For questions to 6 to 17, show your workings clearly and write your answers in the spaces provided. The number of marks available is shown in brackets [] at the end of each question or part-question. (45 marks)

Do not write in this space

- 6 In the morning, there were 750 children at a funfair. 30% of them were girls and the rest were boys. In the afternoon, some more girls joined the funfair and the percentage of girls increased to 40% of the total number of people. How many girls joined the funfair in the afternoon?

Ans: _____ [3]

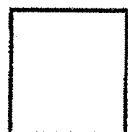

(Go on to the next page)

- 7 Mr Tang bought some apples and oranges. Each apple cost \$0.50 and each orange cost \$0.40. The ratio of the number of apples bought to number of oranges bought was 5 : 2. Mr Tang spent \$23.10 on all the fruits. How many apples did he buy?

Do not
write in
this space

Ans: _____ [3]

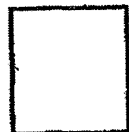

(Go on to the next page)

- 8 Mrs Tan had 47 kg of soap mix. $\frac{5}{8}$ kg of soap mix was needed to make each soap bar. Mrs Tan made as many soap bars as she could. How much soap mix did she have left? Give your answer as a fraction in the simplest form.

Do not
write in
this space

Ans: _____ [3]

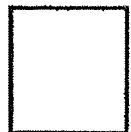

- 9 The table below shows the number of pens sold in a bookstore over a period of 3 months.

Month	March	April	May
Number of pens sold	103	94	97

- (a) Find the average number of pens sold from March to May.

Ans: (a) _____ [1]

- (b) The average number of pens sold from March to July was 15 more than the average number of pens sold from March to May. Write down one possible pair of values for the number of pens sold in June and July.

Ans: (b) _____ and _____ [2]

Do not
write in
this space

- 10 AEF is an isosceles triangle, where $AE = AF$. $\angle ABC = 135^\circ$.
ABE is a right-angled triangle and BCDE is a parallelogram. Find $\angle AEB$.

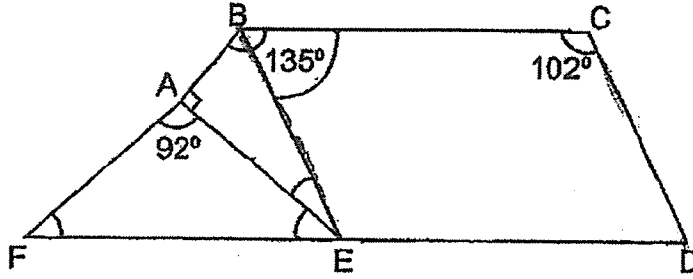

Do not
write in
this space.

Ans: _____ [3]

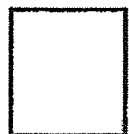

(Go on to the next page)

- 11 There were 380 red and blue marbles in a jar. After $\frac{5}{8}$ of the red marbles and $\frac{1}{4}$ of the blue marbles were taken out, there were 177 marbles left in the jar. How many red marbles were there in the jar at first?

Do not
write in
this space.

Ans: _____ [4]



(Go on to the next page)

- 12 ABCD is a trapezium and BGHC is a rhombus. BE, AD and CE are straight lines.

Do not write in this space.

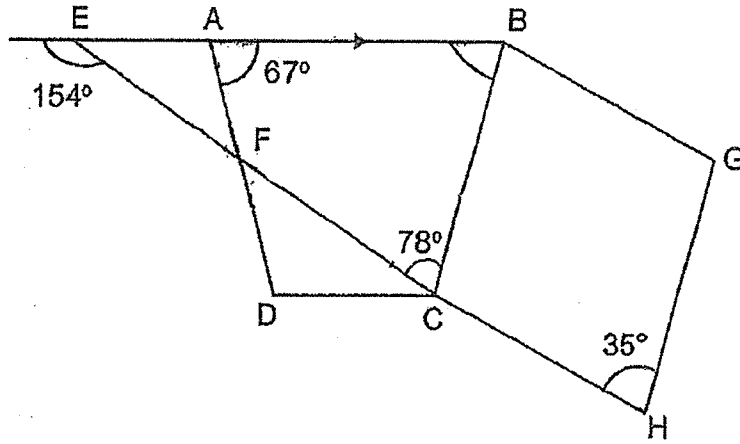

- (a) Find $\angle ABG$.

Ans: (a) _____ [2]

- (b) Find $\angle EFD$.

Ans: (b) _____ [2]

- 13 The graph below shows the cost of hiring a mini-bus from a transport company.

Do not
write in
this space

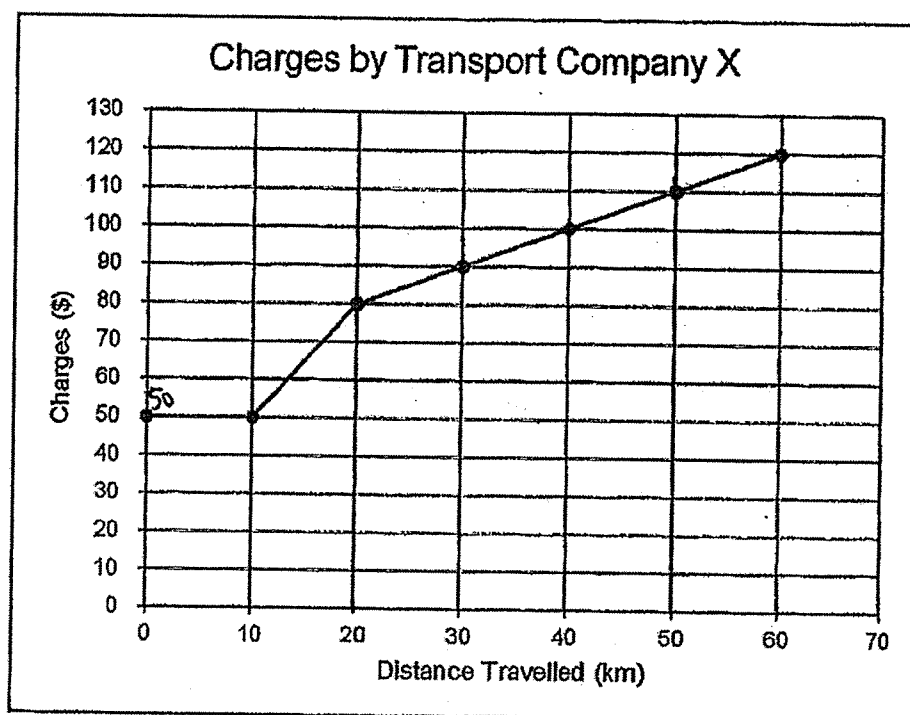

- (a) The distance from Town A to Town B is 6.2 km. What is the cost of hiring the bus to travel from Town A to Town B?

Ans: (a) _____ [1]



(Go on to the next page)

- (b) Mr Tan hired the bus to travel from Town C to Town D and back to Town C using the same route. He paid \$90. What is the distance from Town C to Town D?

Do not
write in
this space

Ans: (b) _____ [2]

- (c) How much does the company charge for every kilometre of travel after the first 20 km?

Ans: (c) _____ [1]

(Go on to the next page)

- 14 The table below shows how a set of numbered cards is distributed among 4 boys.

Alan	Brian	Chris	Daniel
1	2	3	4
8	7	6	5
9	10	11	12
16	15	14	13
17			

- (a) Who will receive the 29th card?

Ans: (a) _____ [1]

- (b) All the cards in the set are distributed. Each boy receives an equal number of cards. The numbers on the cards for each boy add up to 132. How many cards are there altogether?

Ans: (b) _____ [3]

Do not
write in
this space.

15 Joanna paid \$126 for a bag after a discount of 25%.

(a) What was the price of the bag before discount?

Ans: (a) _____ [1]

(b) She paid a discounted price of \$108.80 for a pair of shoes.
The total discount for the pair of shoes and the bag was \$61.20.
What was the percentage discount given for the pair of shoes?

Ans: (b) _____ [3]

Do not
write in
this space.



- 16 Ben had some red, blue and yellow cards. He had 156 more blue cards than red cards and $\frac{2}{3}$ as many yellow cards as red cards. He gave away $\frac{1}{3}$ of his red cards, $\frac{5}{6}$ of his blue cards and 50% of his yellow cards. In the end, he had 250 cards left.

(a) How many cards did Ben have at first?

Ans: (a) _____ [3]

(b) How many blue cards did Ben give away?

Ans: (b) _____ [2]

Do not
write in
this space

- 17 An open rectangular box is shown below.

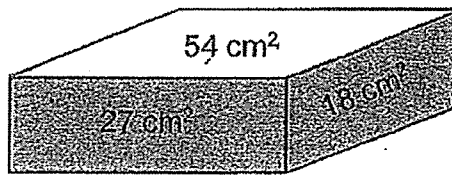

- (a) The outside of the box including its base is painted. Find the painted area.

Ans: (a) _____ [1]

- (b) The box is packed full with 1-cm cubes.

- (i) What is the least number of cubes used?

Ans: (b)(i) _____ [2]

- (ii) How many cubes touch the inside of the box?

Ans: (b)(ii) _____ [2]

Do not
write in
this space.

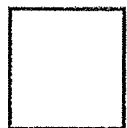
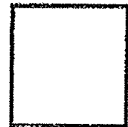

END OF PAPER



SCHOOL : MGS PRIMARY SCHOOL
 LEVEL : PRIMARY 6
 SUBJECT : MATH
 TERM : 2022 SA1

PAPER 1 BOOKLET A

Q 1	Q2	Q3	Q4	Q5	Q6	Q7	Q8	Q9	Q10
4	2	1	3	2	2	4	4	2	4

Q 11	Q12	Q13	Q14	Q15
1	2	1	2	4

PAPER 1 BOOKLET B

Q16)	$2.75 \times 5 = \$13.75$
Q17)	57.5 g
Q18)	$5 \times 24 \div 6 + 27$ $= 120 \div 6 + 27$ $= 20 + 27 = 47$
Q19)	32°
Q20)	

Q21)	$6B : 45 - 36 = 9$ $3B : \frac{9}{4} = 2R1$ $= 9 \text{ box}$									
Q22)	$1h + 1h + 7h + 30\text{min} + 25\text{MIN}$ $= 9H 55 \text{ min}$									
Q23)	$9u = 576$ $1u = \frac{576}{9} = 64$ $4u = 64 \times 4 = 256$									
Q24)	Volume $\rightarrow 60 \times 20 \times 30 = 1200 \times 30 = 3600$ Volume now $\rightarrow 60 \times 20 \times 12 = 1200 \times 12 = 14400$ Needed $\rightarrow 3600 - 14400 = 21600 \text{ cm}^3$									
Q25)	$900 - 700 = 200$ Pour 100ml to B \rightarrow B has 300ml (same as C) <table style="margin-left: auto; margin-right: auto;"> <thead> <tr> <th>A</th> <th>B</th> <th>C</th> </tr> </thead> <tbody> <tr> <td>800</td> <td>300</td> <td>300</td> </tr> <tr> <td>700</td> <td>350</td> <td>350</td> </tr> </tbody> </table> <p style="text-align: center;">Same level</p> ANS: 700ml	A	B	C	800	300	300	700	350	350
A	B	C								
800	300	300								
700	350	350								
Q26)	$A + C = \frac{1}{4} + \frac{1}{4} = \frac{1}{2}$ $\frac{1}{2} + \frac{2}{5} = \frac{9}{10}$ $1 - \frac{9}{10} = \frac{1}{10}$									
Q27)	$14 \times 8 \times \frac{1}{2} = 56$ $56 \times \frac{1}{2} = 28$ $\frac{28}{14 \times 8} = \frac{1}{4}$									
Q28)	$5u = 125.50$ $1u = \frac{125.50}{5} = 25.10$ $2u = 25.10 \times 2 = \$50.20$									

Q29)	<p>Average of M + T $\rightarrow \frac{350+250}{2} = 300$</p> <p>Three days (W + TH + F) $\rightarrow 300 \times 3 = 900$</p> <p>TH + F $\rightarrow 900 - 200 = 700$</p>
Q30)	<p>a) True</p> <p>b) False</p> <p>c) True</p>

PAPER 2

Q1)	<p>$2u = 85 - 18 - 21 + 8 = 28$</p> <p>$1u = \frac{28}{2} = 14$</p> <p>$K \rightarrow 14 + 18 + 21 + 18 = 71$</p>
Q2)	$\angle T = 180 - 77 = 103^\circ$
Q3)	<p>$9 \times 16 = 144$</p> <p>$144 + 24 = 168 \text{ cm}^2$</p>
Q4)	$5 : 3$
Q5)	<p>$32 + 18 + 27 + 48 = 125$</p> <p>$125 - 80 = 45$</p>
Q6)	<p>$420u = 525$</p> <p>$1u = \frac{525}{420} = 1.25$</p> <p>$280u = 280 \times 1.25 = 350$</p> <p>$350 - 225 = 125$</p>
Q7)	<p>$3.3u = 23.10$</p> <p>$1u = \frac{23.10}{3.3} = 7$</p> <p>$5u = 7 \times 5 = 35$</p>
Q8)	<p>Most number $\rightarrow 47 \div \frac{5}{8} = 75.2$</p> <p>Used $\rightarrow 75 \times \frac{5}{8} = 46 \frac{7}{8}$</p>

	Left $\rightarrow 47 - 46\frac{7}{8} = \frac{1}{8}$ kg
Q9)	<p>a) Total $\rightarrow 103 = 94 + 97 = 294$ Average $\rightarrow \frac{294}{3} = 98$</p> <p>b) Average in M \rightarrow July $\rightarrow 98 + 15 = 113$ Total in 5 months $\rightarrow 113 \times 5 = 565$ June + July $\rightarrow 565 - 103 - 94 - 97 = 271$</p> <p>ANS : 100 and 271</p>
Q10)	$\frac{180-92}{2} = 44^\circ$ $\angle EBC = 180^\circ - 102^\circ = 78^\circ$ $135^\circ - 78^\circ = 57^\circ$ $\angle AEB = 90^\circ - 57^\circ = 33^\circ$
Q11)	$\frac{12}{8} R = 432$ $R = 288$
Q12)	<p>a) $\angle ABG = 76 + 35 = 111^\circ$ b) $\angle EFD = 360 - 139 - 41 - 41 = 139^\circ$</p>
Q13)	<p>a) \$50 b) 15km c) \$1</p>
Q14)	<p>a) $29 \div 4 = 7$ (Daniel) b) $8 \times 4 = 32$</p>
Q15)	<p>a) 75% $\rightarrow 126$ 100% $\rightarrow \frac{126}{75} \times 100 = \\168</p> <p>b) Discount for bag $\rightarrow 25\% \rightarrow \frac{126}{75} \times 25 = 42$ Discount for first $\rightarrow 61.20 - 42 = 19.20$ Shoes at first $\rightarrow 108.80 + 129.20 = 128$ $\frac{19.2}{128} \times 100\% = 15\%$</p>
Q16)	<p>a) $7u + 26 = 250$ $7u = 224$ $1u = 32$ $6u + 6u + 4u + 156$ $= 16u + 156$ $= 16 \times 32 + 156 = 668$</p>

	b) $5u + 130 + 32 \times 5 + 130 = 290$
Q17)	a) $27 + 27 + 18 + 18 + 54 = 144\text{cm}^2$ b) i) $9 \times 3 \times 6 = 162$ ii) $7 \times 4 \times 2 = 56$ $162 - 56 = 106$

