



RAFFLES GIRLS' PRIMARY SCHOOL
PRELIMINARY EXAMINATION
PRIMARY SIX
2022

MATHEMATICS
PAPER 1
(BOOKLET A)

Name: _____

Date : 22 August 2022

Class: P6 _____

Total Time : 1 hour

Math Teacher's Name : _____

INSTRUCTIONS TO CANDIDATES

1. Write your Index No. in the boxes at the top right hand corner.
2. Do not turn over this page until you are told to do so.
3. Follow all instructions carefully.
4. Answer all questions.
5. Use a 2B pencil to shade your answers on the Optical Answer Sheet (OAS).
6. The use of calculator is **NOT** allowed.

Booklet A	45
Booklet B	55
Your score out of 100	
Parent's signature	

Questions 1 to 10 carry 1 mark each. Questions 11 to 15 carry 2 marks each.
For each question, four options are given. One of them is the correct answer.
Make your choice (1, 2, 3 or 4). Shade your answer (1, 2, 3 or 4) on the OAS provided.
All diagrams are not drawn to scale.

1. $2\ 090\ 304 = 2\ 000\ 000 + \underline{\hspace{2cm}} + 4$

- (1) 903
- (2) 9030
- (3) 90 300
- (4) 903 000

2. In the number line, what is the value represented by A?

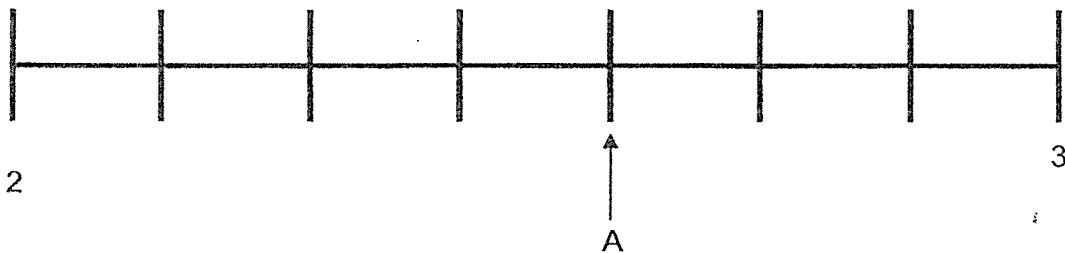

- (1) $2\frac{1}{2}$
- (2) $2\frac{3}{8}$
- (3) $2\frac{4}{7}$
- (4) $2\frac{5}{8}$

3. What is the value of the digit 5 in 78.254?

- (1) 5
- (2) 0.5
- (3) 0.05
- (4) 0.005

4. The area of the shaded face of the cuboid is 27 cm^2 . Its length is 9 cm . Find the volume of the cuboid.

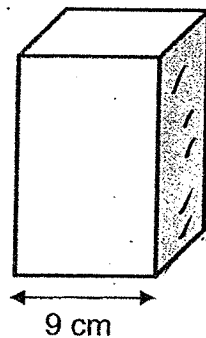

- (1) 3 cm^3
 - (2) 81 cm^3
 - (3) 243 cm^3
 - (4) 729 cm^3
5. In the figure, DEF is an equilateral triangle. Find $\angle z$.

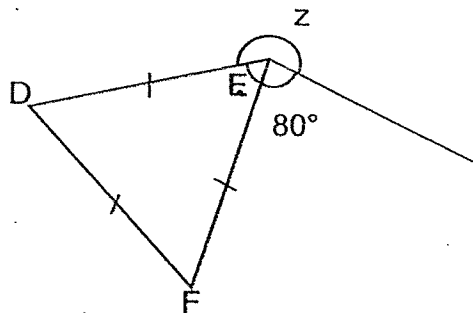

- (1) 280°
- (2) 220°
- (3) 140°
- (4) 100°

6. The figure shows a pyramid.

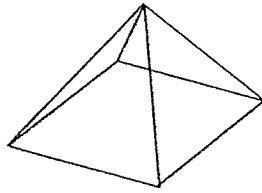

Which of the following is the net of the pyramid?

(A)

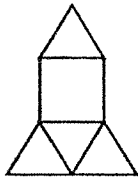

(B)

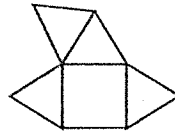

(C)

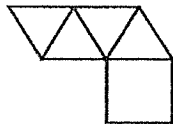

(D)

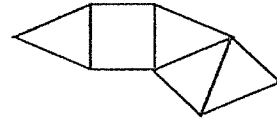

- (1) A
- (2) B
- (3) C
- (4) D

7. The figure shows part of a scale.
Which of the following is closest to the reading shown?

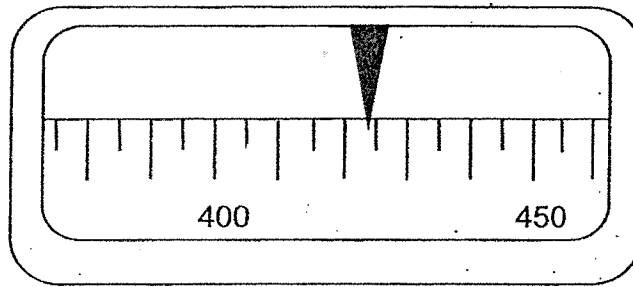

- (1) 405
(2) 410
(3) 425
(4) 430
8. At a concert, $\frac{4}{9}$ of the audience were children and the rest were adults. The number of men was $\frac{1}{2}$ of the number of children. What was the ratio of the number of women to the number of men?
- (1) 2 : 3
(2) 2 : 7
(3) 3 : 2
(4) 7 : 2
9. Minah makes a chain using 12 red beads and 48 blue beads. What percentage of the beads on the chain are red?
- (1) 80%
(2) 75%
(3) 25%
(4) 20%

10. What is the value of $\frac{5y}{2} - y$ when $y = 8$?

- (1) 28
- (2) 20
- (3) 16
- (4) 12

11. Tasty Bakery had an anniversary promotion for their fruit tarts. Mrs Kong bought 72 tarts. What was the least amount of money she had to pay for the tarts?

Tasty Bakery Anniversary Promotion

1 tart for \$3

10 tarts for \$28



- (1) \$196
- (2) \$198
- (3) \$202
- (4) \$216

12. Elyse had a mixture of 10-cents, 20-cents, 50-cents and 1-dollar coins in a bag. She picked up 5 coins from the bag and used two of them. Which of the following is not a possible value of the remaining 3 coins?

- (1) \$1.20
- (2) \$1.80
- (3) \$2.20
- (4) \$2.50

13. Mrs Chan bought a mattress at a 20% discount. She paid \$3200 after the discount. What was the price of the mattress before the discount?
- (1) \$4000
 (2) \$2560
 (3) \$800
 (4) \$640

14. What fraction of the figure is shaded?

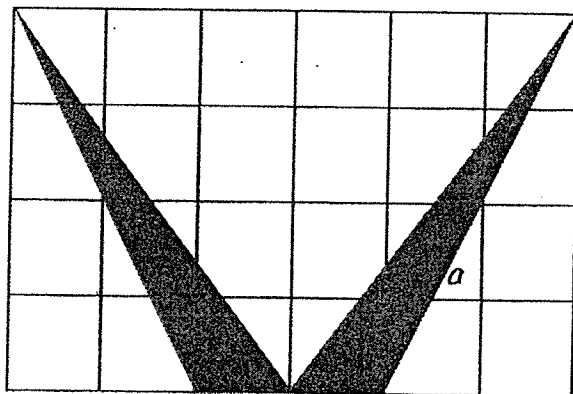

- (1) $\frac{1}{2}$
 (2) $\frac{1}{6}$
 (3) $\frac{1}{3}$
 (4) $\frac{2}{5}$
15. At a fruit stall, mangoes and pears were placed in Box A and Box B. In Box A, the ratio of the number of mangoes to the number of pears was 3 : 4. In Box B, the ratio of the number of mangoes to the number of pears was 3 : 5. There were 4 times as many fruits in Box B as in Box A. What was the ratio of the number of pears in Box A to the number of pears in Box B?
- (1) 1 : 5
 (2) 2 : 7
 (3) 4 : 5
 (4) 8 : 35

End of Paper
 ☺ Please check your work carefully ☺

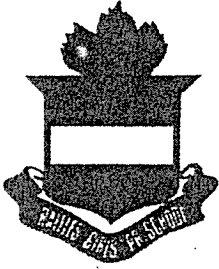

RAFFLES GIRLS' PRIMARY SCHOOL
PRELIMINARY EXAMINATION
PRIMARY SIX
2022

MATHEMATICS
PAPER 1
(BOOKLET B)

Name: _____

Date : 22 August 2022

Class: P6 _____

Total Time : 1 hour

Math Teacher's Name :

INSTRUCTIONS TO CANDIDATES

1. Write your Index No. in the boxes at the top right hand corner.
2. Do not turn over this page until you are told to do so.
3. Follow all instructions carefully.
4. Answer all questions.
5. Use a dark blue or black ballpoint pen to write your answers in the space provided for each question.
6. Do not use correction fluid/tape or highlighters
7. The use of calculator is **NOT** allowed.

Questions 16 to 20 carry 1 mark each. Write your answers in the spaces provided. For questions which require units, give your answers in the units stated. All diagrams are not drawn to scale. Answers in fractions or ratio must be expressed in the simplest form.

16. Find the value of $7 \times (54 - 24 \div 6) + 4$.

Ans: _____

17. A charity concert starts at 7.45 p.m. There is a break of 10 minutes. The concert is 1 h 45 min long excluding the break. At what time does the concert end? Give your answer in 24-hour clock.

Ans: _____

18. Express $\frac{56}{6}$ as a mixed number in the simplest form.

Ans: _____

19. Find the value of $9.03 - 0.38$.

Ans: _____

20. The average mass of Mr Lim and his 2 children, Andy and Benny, is 44 kg. The total mass of Andy and Benny is the same as Mr Lim's mass. What is Mr Lim's mass?

Ans: _____ kg

Questions 21 to 30 carry 2 marks each. Show your working clearly in the space provided for each question and write your answers in the space provided. For questions which require units, give your answers in the units stated. All diagrams are not drawn to scale. Answers in fractions or ratio must be expressed in the simplest form.

21. a) Find the value of $\frac{3}{4} + \frac{1}{5}$

b) Find the value of $\frac{4}{5} \div 12$

Ans: a) _____

b) _____

22. Fiona bought 350 m of ribbon to make some bow ties. She used up all the ribbon to make 200 large bow ties and 100 small bow ties. She needed 1.34 m of ribbon to make one large bow tie. What was the length of ribbon needed to make one small bow tie?

Ans: _____ m

23. The figure is made up of two identical overlapping rectangles. The overlapping part forms a square of side $2p$ cm. Find the perimeter of the figure in terms of p .

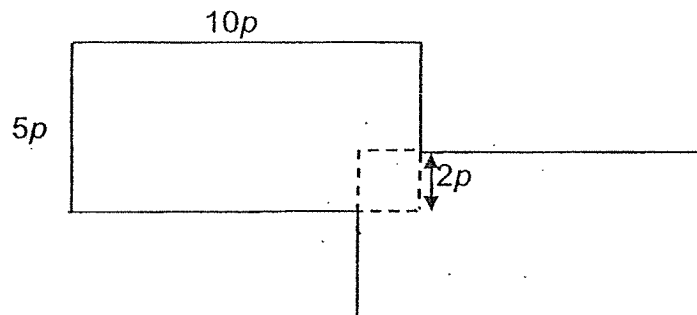

Ans: _____ cm

24. Gupta walked from his home to school which was 2.4 km away. He walked at an average speed of 80 m/min. How many minutes did he take to reach school?

Ans: _____

25. In the figure below, CD is parallel to FE and FE is parallel to GH . Find the sum of $\angle a$, $\angle b$ and $\angle c$.

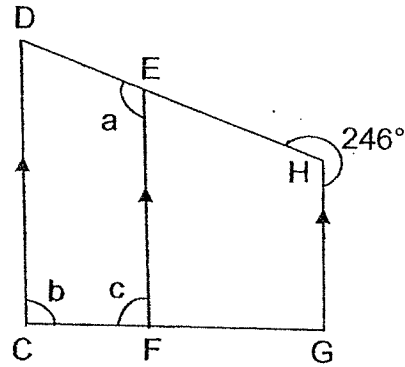

Ans: _____°

26. The table shows charges for bicycle rental.

BICYCLE FOR RENTAL	
For the first hour	\$2
For every additional $\frac{1}{2}$ hour	\$0.80

Kaitlyn rented a bicycle from 9.00 a.m. to 10.45 a.m. How much did she pay?

Ans: \$ _____

27. The figure is formed using 2 squares and 2 equilateral triangles. The length of the straight line AB is 25 cm. Find the perimeter of the figure.

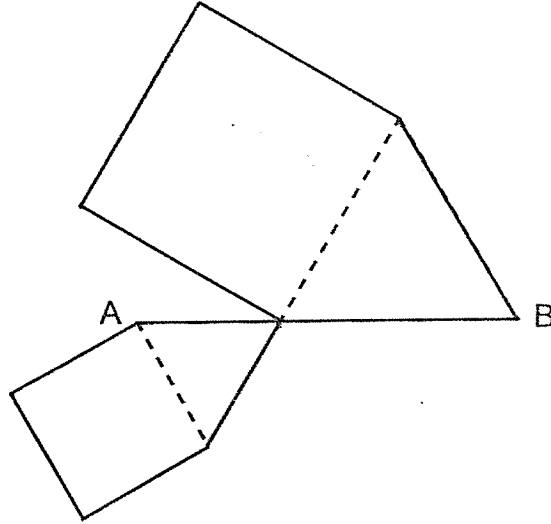

Ans: _____ cm

28. Yan and Lynn had some stickers. After Yan gave 34 stickers to Lynn, she had 60 stickers more than Lynn. How many more stickers than Lynn did Yan have at first?

Ans: _____

29. The pie chart shows the survey results of the favourite rides of a group of children who went to Universal Studios. 240 pupils enjoyed the Revenge of the Mummy ride.

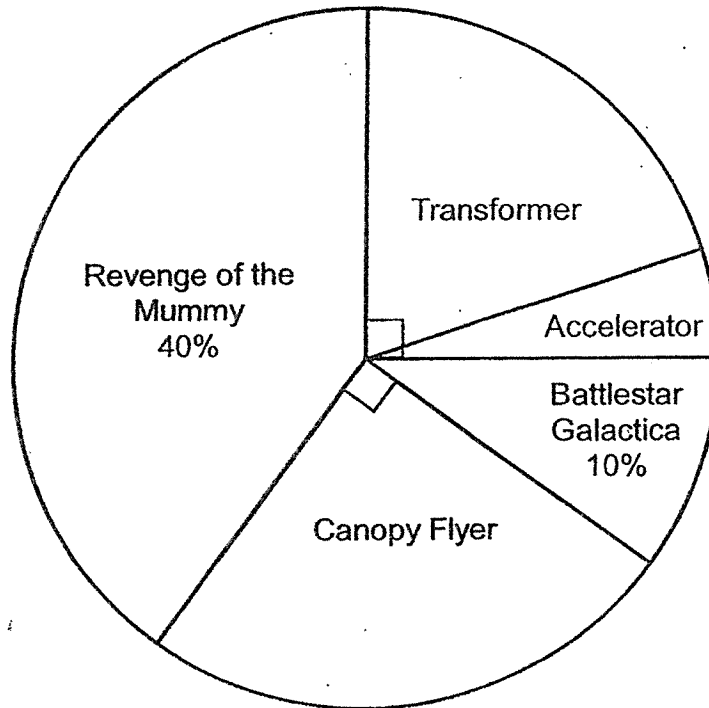

The ratio of the number of pupils who enjoyed the Transformer ride to the number of pupils who enjoyed the Accelerator ride was 4 : 1. How many pupils enjoyed the Accelerator ride?

Ans: _____

30. Mr Min used $\frac{4}{7}$ of his money to buy 6 apples and 9 oranges. The cost of 3 apples was the same as that of 2 oranges. With the money he had left, what was the most number of oranges Mr Min could buy?

Ans: _____

End of Paper
© Please check your work carefully ☺

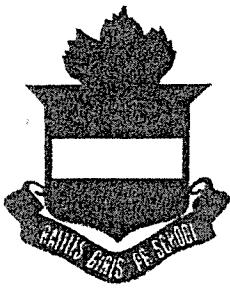
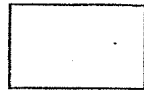

**RAFFLES GIRLS' PRIMARY SCHOOL
PRELIMINARY EXAMINATION
PRIMARY SIX
2022**

**MATHEMATICS
PAPER 2**

Name: _____

Date : 22 August 2022

Class: P6 _____

Total Time : 1 hour 30 min

Math Teacher's name : _____

INSTRUCTIONS TO CANDIDATES

1. Write your Index No. in the boxes at the top right hand corner.
2. Do not turn over this page until you are told to do so.
3. Follow all instructions carefully.
4. Answer all questions.
5. Use a dark blue or black ballpoint pen to write your answers in the space provided for each question.
6. Do not use correction fluid/tape or highlighters.
7. The use of an approved calculator is allowed.

Mark	55
------	----

Questions 1 to 5 carry 2 marks each. Show your working clearly in the space provided for each question and write your answers in the spaces provided. Figures are not drawn to scale.

For questions which require units, give your answers in the units stated.

Answers in fractions or ratio must be expressed in the simplest form. (10 marks)

1. A carton of eggs cost \$2.40 last year. This year, the same carton of eggs costs \$3. What is the percentage increase in the price of a carton of eggs?

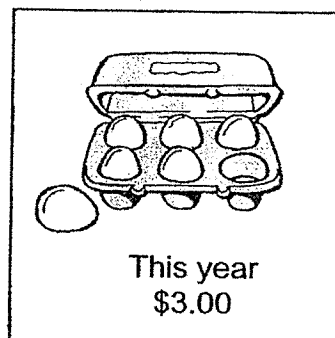
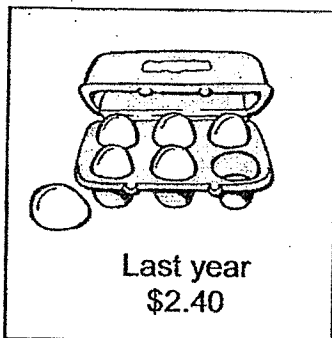

Ans : _____ % [2]

2. A group of pupils were asked to choose one activity from canoeing, running, swimming and archery. The pie chart shows the pupils' choices. $\frac{1}{2}$ of the number of pupils preferred swimming and archery.

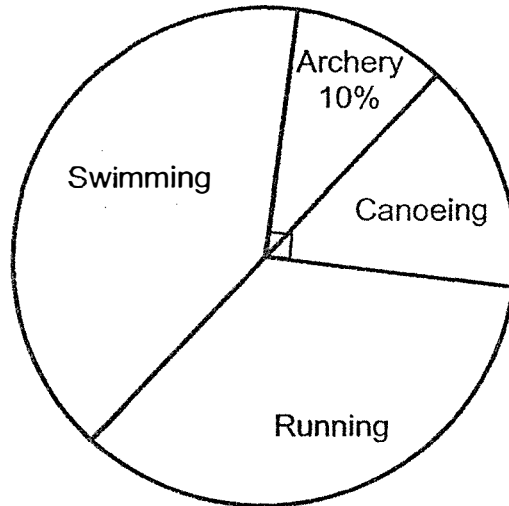

- a) What percentage of the pupils preferred running?
 b) The pupils' choices were also represented by a bar graph. The bars for archery and swimming were not drawn.
 How many pupils preferred running and archery?

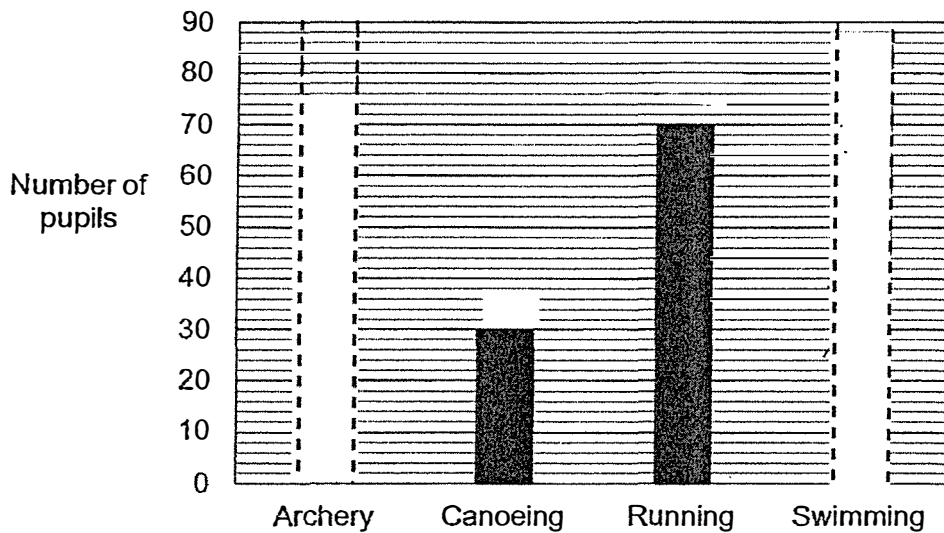

Ans : (a) _____ [1]

(b) _____ [1]

3. PQRS is a rhombus. PR and PT are straight lines. $\angle PQR = 104^\circ$ and $\angle PTR = 120^\circ$. Find $\angle TPR$.

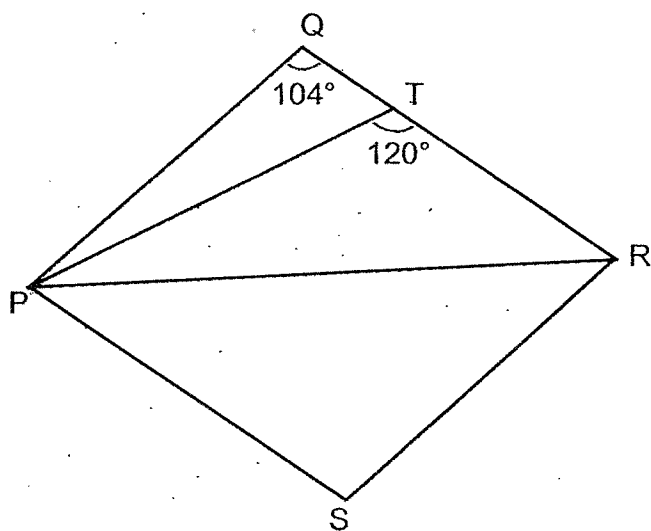

Ans : _____° [2]

4. At a dinner party, the ratio of the number of men to the number of women was 5 : 4. Another 56 women joined them after the dinner had started. The ratio of the number of men to the number of women became 3 : 4. How many people were at the dinner party in the end?

Ans : _____ [2]

5. Auntie Wendy sells strawberry and chocolate cakes in the canteen. The bar graphs show the number of strawberry and chocolate cakes sold from January to March. The difference in the number of strawberry and chocolate cakes sold in January is 4y.

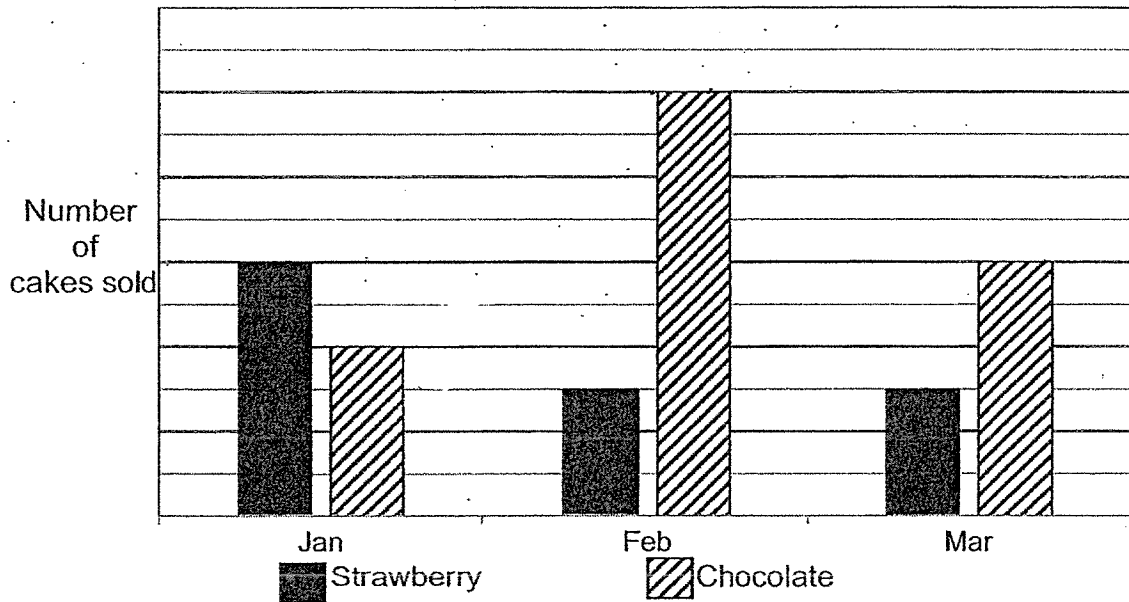

Each of the statements below is either true, false or not possible to tell from the information given. For each statement, put a tick(✓) to indicate your answer. [2]

Statement	True	False	Not possible to tell
(a) The total number of cakes sold from January to March is 64y.			
(b) The average number of chocolate cakes sold in February and March is 5y more than the average number of strawberry cakes sold in February and March.			
(c) The number of cakes sold in February is 16 more than the number of cakes sold in March.			

For questions 6 to 17, show your working clearly in the space provided for each question and write your answers in the spaces provided.
 The number of marks available is shown in the brackets [] at the end of each question or part-question.

Figures are not drawn to scale.

Answers in fractions or ratio must be expressed in the simplest form. (45 marks)

6. The shaded figure is made up of 4 small quarter circles and 1 big quarter circle on 9 identical squares. The area of each square is 49 cm^2 . Find the area of the shaded part. Take $\pi = \frac{22}{7}$.

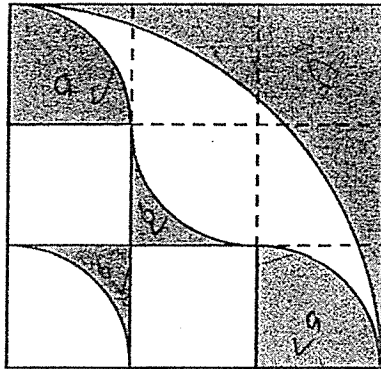

Ans : _____ [3]

7. ABCD is a parallelogram and LGJD is a trapezium. EB is a straight line, AB is parallel to HG, $\angle DBC = 75^\circ$, $\angle GLD = 65^\circ$, $\angle HEK = 64^\circ$ and $\angle BCD = 65^\circ$.
- (a) Find $\angle KDJ$.
- (b) Find $\angle EHG$.

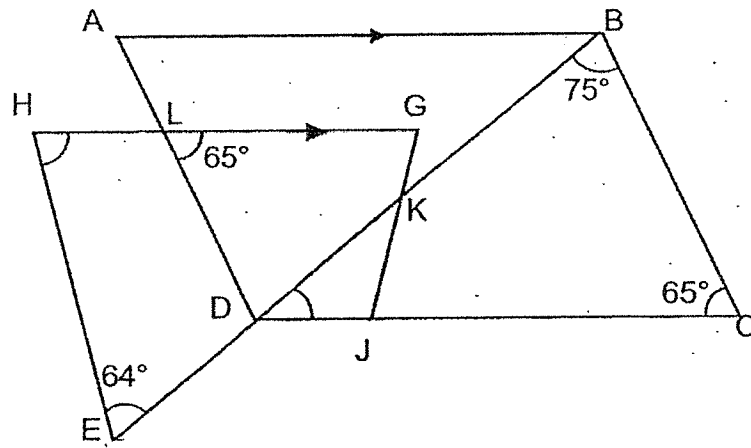

Ans: (a) _____ [1]

(b) _____ [2]

8. The table consists of numbers from 1 to 64. John is given a plastic frame that covers exactly 9 squares of the table with the centre square darkened.

1	2	3	4	5	6	7	8
9	10	11	12	13	14	15	16
17	18	19	20	21	22	23	24
25	26	27	28	29	30	31	32
33	34	35	36	37	38	39	40
41	42	43	44	45	46	47	48
49	50	51	52	53	54	55	56
57	58	59	60	61	62	63	64

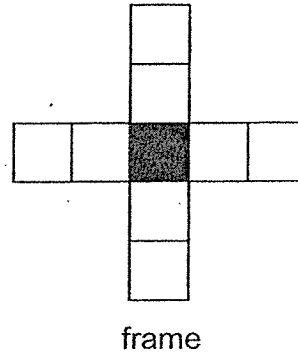

- a) John puts the frame on 9 squares shown in the figure. What is the average of the 8 numbers that can be seen in the frame?

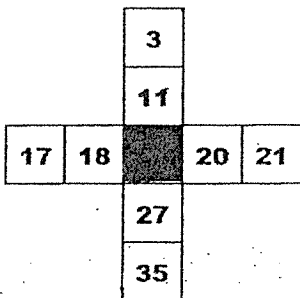

- b) Next, John puts the frame on some other 9 squares. The sum of the 8 numbers that can be seen in the frame is 296. What is the largest number than can be seen in the frame?

Ans : a) _____ [1]

b) _____ [2]

9. Jennie bought some pens at \$1.80 each. Mary bought some notebooks at \$2.50 each. Jennie bought 9 more items than Mary and spent \$5 more than she did. How many notebooks did Mary buy?

Ans : _____ [3]

10. The table shows the number of children visiting the Science Centre from June to September.

Month	Boys	Girls
June	235	121
July	123	81
August	111	89
September	140	?

- (a) The number of children visiting Science Centre in August and September is 75% of the number of children visiting in June and July. How many girls visited the Science Centre in September?
- (b) From September to October, there was a 20% increase in the number of boys. Find the number of boys at the Science Centre in October.

Ans: (a) _____ [2]

(b) _____ [1]

11. A tank was $\frac{1}{15}$ filled with water. After Tap A was turned on for 12 min, Tap B was also turned on. After another 16 min, both Tap A & Tap B were turned off at the same time. The line graph shows the volume of water in the tank over 28 min.

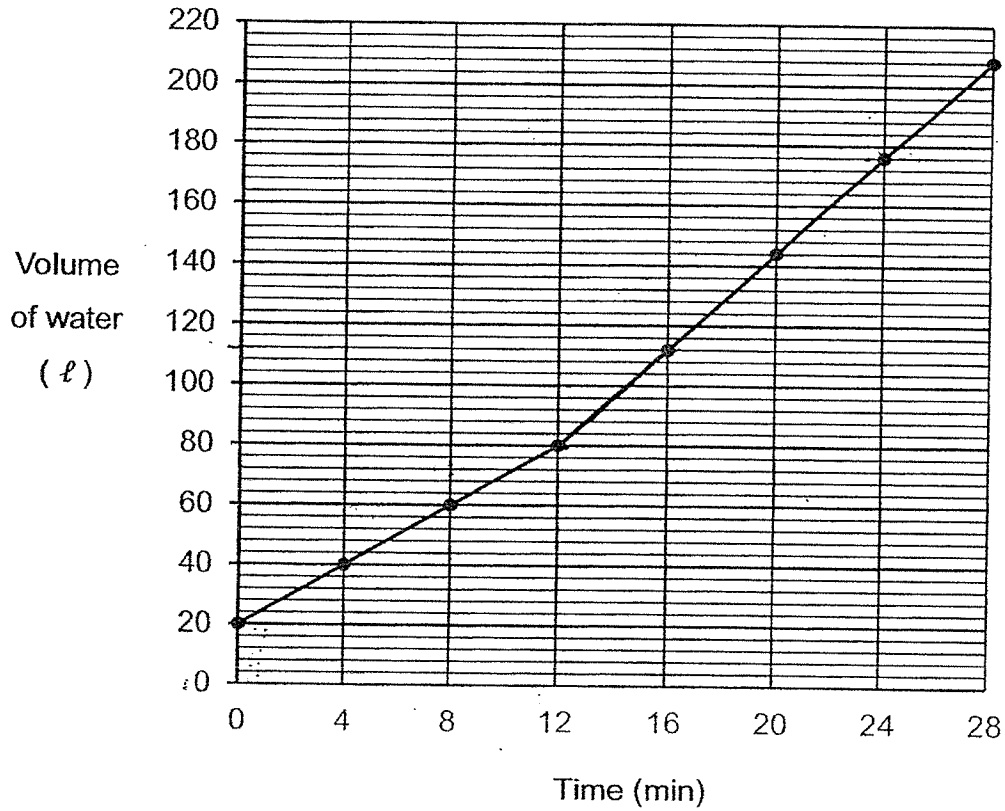

- What was the volume of the tank?
- How many litres of water flowed from Tap A in 12 minutes?
- In one minute, how many litres of water flowed from Tap B?

Ans: (a) _____ [1]

(b) _____ [1]

(c) _____ [2]

12. The bar graph shows the number of pens sold from January to April. The number of pens sold is not shown on the scale.

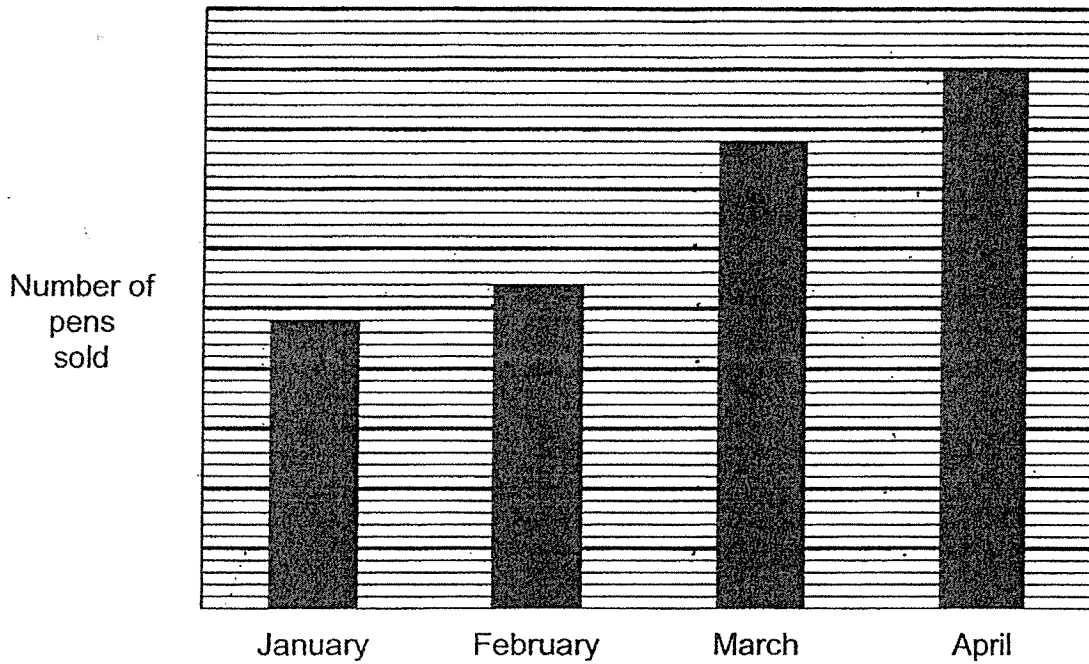

- a) Mr Yoong sold a total of 540 pens. How many pens were sold in March?
- b) In April, Mr Yoong reduced the price of pens by 20%. The original price of each pen was \$2.00. What was the total amount of money collected from the pens sold in April?

Ans: (a) _____ [2]

(b) _____ [2]

13. Figure 1 shows Tank X, which is completely filled with water, and Tank Y, which is empty. Water is poured from Tank X into Tank Y without spilling. The heights of the water level in the two tanks are now equal as shown in Figure 2.

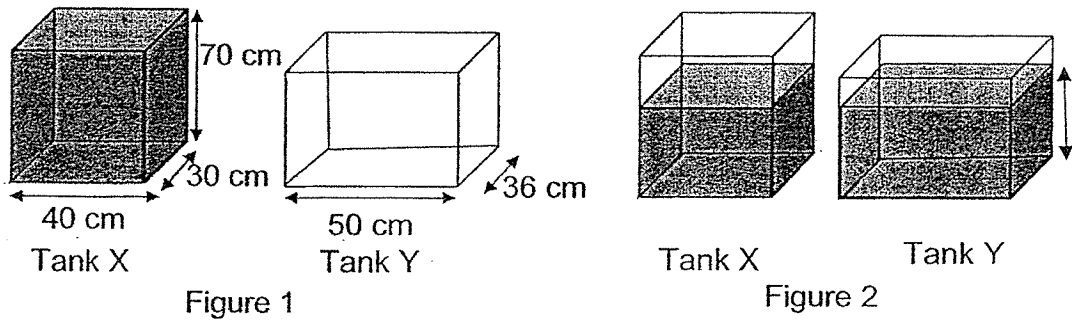

- a) What is the capacity of Tank X?
b) What is the height of the water in Tank Y in Figure 2?

Ans: (a) _____ [1]

(b) _____ [3]

14. The figure is formed using one rectangle ABCD and two identical squares EFCG and JKEM. EC is a straight line, $DE = DH$ and $\angle BCF = 20^\circ$.
- (a) Find $\angle EDH$.
- (b) Find $\angle KLA$.

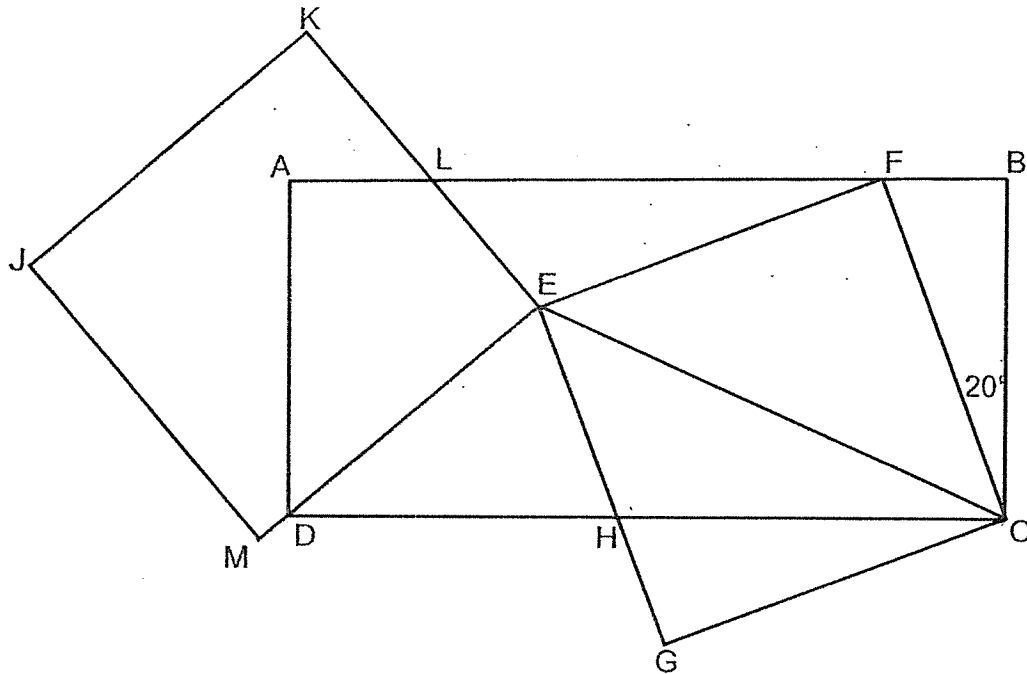

Ans: (a) _____ [2]
 (b) _____ [2]

15. The figure is formed by 1 small semicircle, 2 identical medium semicircles and 1 big semicircle. PQRS is a straight line.
- (a) What is the length of QR?
- (b) Use the calculator value of π to find the perimeter of the shaded figure. Round your answer to 2 decimal places.

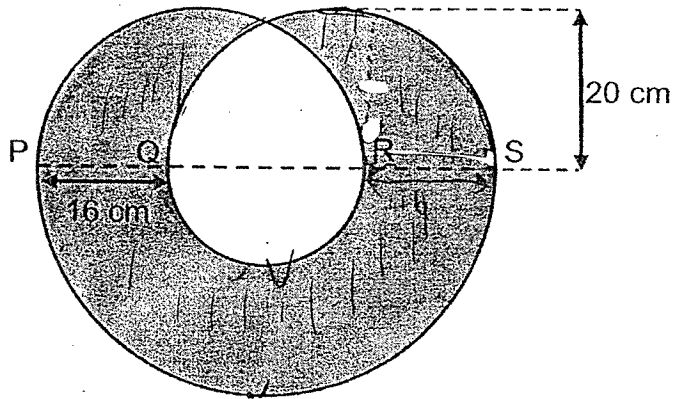

Ans: (a) _____ [1]

(b) _____ [3]

16. A painter mixed red, blue and white paint to form a mixture of purple paint. $\frac{1}{4}$ of the purple paint was made up of red paint. The ratio of the volume of blue paint to the volume of red paint was 2 : 3.

a) What fraction of the purple paint mixture was from the white paint?

b) He then used $\frac{3}{8}$ of the purple paint to paint the wall and $\frac{2}{3}$ of the remaining purple paint to paint the ceiling. He had 300 *ml* of purple paint left.

What was the volume of the purple paint mixture at first?

Ans: (a) _____ [2]

(b) _____ [3]

17. Sulin bought a total of 1540 beads in 3 different shapes for her craft work. The ratio of round beads to square beads is 1 : 7. She used $\frac{2}{3}$ of the square beads and all of the round beads. Half of the triangular beads were left. In the end, the total number of beads left was 675.

- a) What was the ratio of the total number of round and square beads used to the total number of round and square beads left?
- b) What was the number of triangular beads at first?

Ans: (a) _____ [2]

(b) _____ [3]

End of Paper
Please check your work carefully ☺

YEAR : 2022
 LEVEL : PRIMARY 6
 SCHOOL : RAFFLES GIRLS' PRIMARY SCHOOL
 SUBJECT : MATHEMATICS
 TERM. : PRELIMINARY EXAMINATION

PAPER 1 (BOOKLET A)

Q1	3	Q2	3	Q3	3	Q4	3	Q5	2
Q6	1	Q7	3	Q8	3	Q9	4	Q10	4
Q11	3	Q12	2	Q13	1	Q14	2	Q15	4

(BOOKLET B)

Q16	$(54 - 4)$ $7 \times 50 + 4$ $= 354$		
Q17	21 40		
Q18	$9\frac{1}{3}$		
Q19	8.65		
Q20	$44 \times 3 = 132$ $A + B : 2u$ $Mr L : 2u$ $4u = 132$ $1u = 33$ $33 \times 2 = 66 \text{ kg}$		
Q21	a)	$\frac{3}{4} = \frac{15}{20}$ $\frac{15}{20} + \frac{4}{20} = \frac{19}{20}$	
	b)	$\frac{4}{5} \times \frac{1}{12} = \frac{1}{15}$	
Q22	Meters needed for 200 large : 1.34×200 $= 2.68 \times 100$ $= 268$ Meters needed for 100 skills : $350 - 268 = 82$ One by : $82 \div 100 = 0.82\text{m}$		
Q23	$10p - 2p = 8p$ $10p + 5p + 8p + 3p + 3p + 10p + 5p + 8p +$ $= (52p) \text{ cm}$		
Q24	$2.4 \times 1000 = 2400$ $2.4\text{km} = 2400\text{m}$ $D \div S = T$ $\frac{2400}{80} = 30\text{min}$		

Q25	$b = 114$ $c = 180 - 114$ $= 66$ $180 - 66 = 114$ $114 + 114 + 66 = 228 + 66$ $= 294$
Q26	$\$2 + 0.50 + 0.80 = \3.60
Q27	$25 \times 5 = 125 \text{ cm}$
Q28	$2u = 94 + 34$ $= 128$
Q29	T : A 4 : 1 5u : 25% 1u : 5% 40% : 240 1% : 6 5% : $6 \times 5 = 30$
Q30	$3A = 20$ $6A = 40$ $4u : 13 \text{ oranges}$ $1u = 13 \text{ oranges} \div 4\frac{13}{4}$ $= 3R1$ $3u = 3R1 \times 3$ $= 9R3$

YEAR : 2022
 LEVEL : PRIMARY 6
 SCHOOL : RAFFLES GIRLS' PRIMARY SCHOOL
 SUBJECT : MATHEMATICS
 TERM : PRELIMINARY EXAMINATION

(PAPER 2)

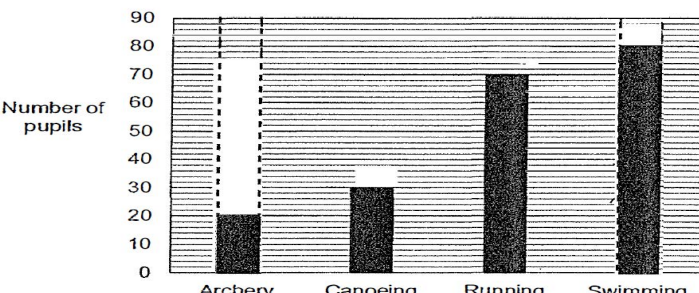
Q1	$3 - 2.40 = 0.60$ $\frac{\text{inc}}{\text{last yr}} = \frac{0.60}{2.40} \times 100 = 25$ <p>Increase : $3 - 2.40 = 0.60$</p> $\frac{0.60}{2.40} \times 100 = 25\%$																
Q2	$25 - 10 = 15$ $50 - 15 = 35$ $15\% : 30$ $1\% : 30 \div 15 = 2$ $35\% : 35 \times 2$ $= 70$ $10\% = 2 \times 10$ $= 20$ <div style="text-align: center;">  <table border="1" style="margin: 10px auto;"> <caption>Number of Pupils by Sport</caption> <thead> <tr> <th>Sport</th> <th>Number of Pupils</th> </tr> </thead> <tbody> <tr> <td>Archery</td> <td>20</td> </tr> <tr> <td>Canoeing</td> <td>30</td> </tr> <tr> <td>Running</td> <td>70</td> </tr> <tr> <td>Swimming</td> <td>80</td> </tr> </tbody> </table> </div> <p>a) 35%</p> <p>b) 90</p>	Sport	Number of Pupils	Archery	20	Canoeing	30	Running	70	Swimming	80						
Sport	Number of Pupils																
Archery	20																
Canoeing	30																
Running	70																
Swimming	80																
Q3	$(180 - 104) \div 2 = 38$ $180 - 38 - 120 = 22^\circ$																
Q4	$8u = 56$ $1u = 56 \div 8$ $= 7$ $7 \times (15 + 20) = 245$																
Q5	<table border="1" style="width: 100%; text-align: center;"> <thead> <tr> <th style="width: 25%;">Statement</th> <th style="width: 25%;">True</th> <th style="width: 25%;">False</th> <th style="width: 25%;">Not to possible</th> </tr> </thead> <tbody> <tr> <td>(a)</td> <td>✓</td> <td></td> <td></td> </tr> <tr> <td>(b)</td> <td></td> <td>✓</td> <td></td> </tr> <tr> <td>(c)</td> <td></td> <td></td> <td>✓</td> </tr> </tbody> </table>	Statement	True	False	Not to possible	(a)	✓			(b)		✓		(c)			✓
Statement	True	False	Not to possible														
(a)	✓																
(b)		✓															
(c)			✓														
Q6	$2 \text{ square} : (7 \times 7) \times 2 = 98$ $\text{Area of a} : 21 \times 21 = 441$ $441 - 1 \frac{1}{4} \times \frac{22}{7} \times 21 \times 711$ $98 + 94.5 = 192.5 \text{ cm}^2$																

Q7	$180 - 75 - 65 = 40$ $180 - 65 = 115$ $115 - 75 = 40$ $180 - 75 = 105$ $180 - 65 = 115$ $360 - 115 - 105 - 64 = 76$ a) 40° b) 76°																																																																
Q8	<table border="1" data-bbox="279 515 742 817"> <tbody> <tr><td>1</td><td>2</td><td>3</td><td>4</td><td>5</td><td>6</td><td>7</td><td>8</td></tr> <tr><td>9</td><td>10</td><td>11</td><td>12</td><td>13</td><td>14</td><td>15</td><td>16</td></tr> <tr><td>17</td><td>18</td><td>19</td><td>20</td><td>21</td><td>22</td><td>23</td><td>24</td></tr> <tr><td>25</td><td>26</td><td>27</td><td>28</td><td>29</td><td>30</td><td>31</td><td>32</td></tr> <tr><td>33</td><td>34</td><td>35</td><td>36</td><td>37</td><td>38</td><td>39</td><td>40</td></tr> <tr><td>41</td><td>42</td><td>43</td><td>44</td><td>45</td><td>46</td><td>47</td><td>48</td></tr> <tr><td>49</td><td>50</td><td>51</td><td>52</td><td>53</td><td>54</td><td>55</td><td>56</td></tr> <tr><td>57</td><td>58</td><td>59</td><td>60</td><td>61</td><td>62</td><td>63</td><td>64</td></tr> </tbody> </table> <p>a) $3 + 11 + 17 + 18 + 27 + 35 + 20 + 21$ $= 152$ $152 \div 8 = 19$ $296 \div 8 = 37$ Total of the 8 numbers divide 8 to find out average</p> <p>b) $21 + 29 + 35 + 36 + 45 + 53 + 38 + 39$ $= 296$ Ans: 53</p>	1	2	3	4	5	6	7	8	9	10	11	12	13	14	15	16	17	18	19	20	21	22	23	24	25	26	27	28	29	30	31	32	33	34	35	36	37	38	39	40	41	42	43	44	45	46	47	48	49	50	51	52	53	54	55	56	57	58	59	60	61	62	63	64
1	2	3	4	5	6	7	8																																																										
9	10	11	12	13	14	15	16																																																										
17	18	19	20	21	22	23	24																																																										
25	26	27	28	29	30	31	32																																																										
33	34	35	36	37	38	39	40																																																										
41	42	43	44	45	46	47	48																																																										
49	50	51	52	53	54	55	56																																																										
57	58	59	60	61	62	63	64																																																										
Q9	Cost of 9 more pens $1.80 \times 9 = 16.20$ $16.20 - 5 = 11.20$ $11.20 \div 2.50 = 4.48$ $2.50 - 1.80 = 0.70$ No. of notebooks = $11.20 \div 0.70$ $= 16$																																																																
Q10	$235 + 121 + 123 + 81 = 560$ $75\% \times 560 = 420$ $420 - 111 - 140 - 89 = 80$ $100\% : 140$ $1\% : 1.4$ $120\% : 168$ a) 80 b) 168																																																																
Q11	$\frac{1}{15} : 20$ $\frac{15}{15} : 20 \times 15 = 300 \text{ l (a)}$ $4 \text{ min} : 420 \text{ ml}$ $1 \text{ min} : 5 \text{ l}$ $112 - 80 = 32$ $32 - 20 = 12$ $12 \div 4 = 3 \text{ L (c)}$ $10 \text{ min} \rightarrow 5 \times 12 = 60$ OR $80 - 20 = 60 \text{ l (b)}$																																																																
Q12	$45 + 39 + 27 + 24 = 135$																																																																

	$135u = 540$ $1u = 540 \div 135$ $= 4$ $4 \times 39 = 156$ $45 \times 4 = 180$ $\frac{80}{100} \times 2 = 1.60$ $180 \times 1.60 = 288$ a) \$156 b) \$288
Q13	$40 \times 30 \times 70 = 84000$ $1800 + 1200 = 3000$ $84000 \div 3000 = 28\text{cm}$ a) 84L b) 28 cm

Q14	$ECH = 90 - 45 - 20$ $= 25$ $EHC = 180 - 45 - 25$ $= 110$ $180 - 110 = 70$ $180 - 70 - 70$ $= 40^\circ$ (a) $ALE = 360 - 90 - 90 - 50$ $= 130$ $180 - 130 = 50^\circ$ (b)
-----	--

Q15	$40 - 16 = 24$ $\frac{1}{2} \times \pi \times 56 = 28\pi$ 2 medium semi : $(\frac{1}{2} \times \pi \times 40) \times 2$ $= 40\pi$ $12\pi + 28\pi + 40\pi = 80\pi$ $80\pi \approx 251.33$ a) 24cm b) 251.33 cm
-----	--

Q16	$\frac{12}{48}$: red $\frac{8}{48}$: blue $48 - 8 - 12 = 28$ $\frac{28}{48} = \frac{7}{12}$ $1u = 300$ $300 \times 3 = 900$ $5u = 900$ $1u = 180$ $180 \times 8 = 1440$ a) $\frac{7}{12}$ b) 1440ml
-----	---

Q17	R : S
-----	-------

$$1:7$$

$$3:21$$

$$\frac{2}{3} \times 21 = 14$$

$$U:L$$

$$17:7$$

$$17+7=24$$

$$1540 - 675 = 865$$

$$865 - 675 = 190$$

$$17u - 7u = 10u$$

$$10u : 190$$

$$1u : 19$$

$$17 + 7 = 24u$$

$$24u : 456$$

$$1540 - 456$$

$$= 1084$$

$$a) 17:7$$

$$b) 1084$$

6
END