



**CATHOLIC HIGH SCHOOL**  
**PRELIMINARY EXAMINATION (2022)**  
**PRIMARY SIX**  
**MATHEMATICS**  
**PAPER 1**  
**(BOOKLET A)**

Name : \_\_\_\_\_ ( )

Class : Primary 6 \_\_\_\_\_

Date : 22 August 2022

Total time for Booklet A and B : 1 hour

15 questions

20 marks

Parent's signature : \_\_\_\_\_

**INSTRUCTIONS TO CANDIDATES**

Do not turn over this page until you are told to do so.

Follow all instructions carefully.

Answer all questions.

Shade your answers in the Optical Answer Sheet (OAS) provided.

The use of calculators is **NOT** allowed.

This booklet consists of 8 printed pages.



Questions 1 to 10 carry 1 mark each. Questions 11 to 15 carry 2 marks each. For each question, four options are given. One of them is the correct answer. Make your choice (1, 2, 3 or 4). Shade the oval (1, 2, 3 or 4) on the Optical Answer Sheet.  
All diagrams are not drawn to scale. (20 marks)

---

1. Which of the following is four hundred thousand and two in numerals?

- (1) 402
  - (2) 4002
  - (3) 40 002
  - (4) 400 002
- 

2. What is the value of  $4 \div 800$ ?

- (1) 0.005
  - (2) 0.02
  - (3) 50
  - (4) 200
- 

3. What is the length of the safety pin as shown in the figure?

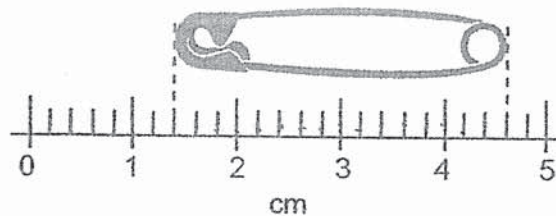

- (1) 3.1 cm
  - (2) 3.2 cm
  - (3) 4.3 cm
  - (4) 4.6 cm
-

4. Which one of the following is likely to be the mass of a scientific calculator?



- (1) 9 g
  - (2) 90 g
  - (3) 900 g
  - (4) 9000 g
- 

5. Find the value of  $\frac{14m}{3} + 1$  when  $m = 6$ .

- (1)  $5\frac{2}{3}$
  - (2) 28
  - (3)  $28\frac{1}{3}$
  - (4) 29
- 

6. Which of the following is the same as 70 l 90 ml?

- (1) 7 090 ml
  - (2) 7 900 ml
  - (3) 70 090 ml
  - (4) 70 900 ml
-

7. A square is first divided into two equal halves. The left half is divided into 3 equal parts while the right half is divided into 4 equal parts. What fraction of the square is shaded?

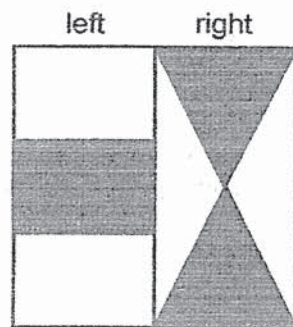

- (1)  $\frac{5}{12}$   
 (2)  $\frac{5}{11}$   
 (3)  $\frac{3}{7}$   
 (4)  $\frac{3}{4}$

8. Shamsul was North-East of Teddy. At first, they were facing each other. Then both boys made the smallest turn to face North. Which of the following represents the turn made by each boy?



- |     | <u>Shamsul</u>      | <u>Teddy</u>        |
|-----|---------------------|---------------------|
| (1) | 135° anti-clockwise | 45° clockwise       |
| (2) | 135° clockwise      | 45° anti-clockwise  |
| (3) | 45° anti-clockwise  | 135° clockwise      |
| (4) | 45° clockwise       | 135° anti-clockwise |

9. ABCD is a rectangle. E and F are points on the rectangle.  $\angle ADF = 280^\circ$  and  $\angle EDC = 60^\circ$ . Find  $\angle EDF$ .

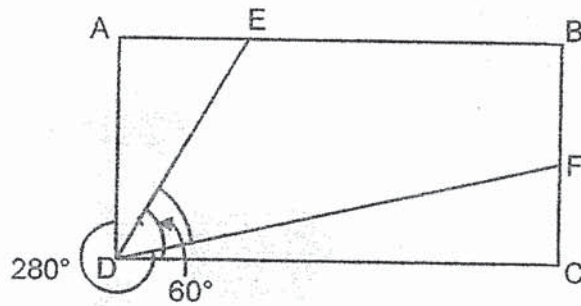

- (1)  $20^\circ$
- (2)  $30^\circ$
- (3)  $45^\circ$
- (4)  $50^\circ$

10. The line graph shows the number of books sold from Monday to Thursday.

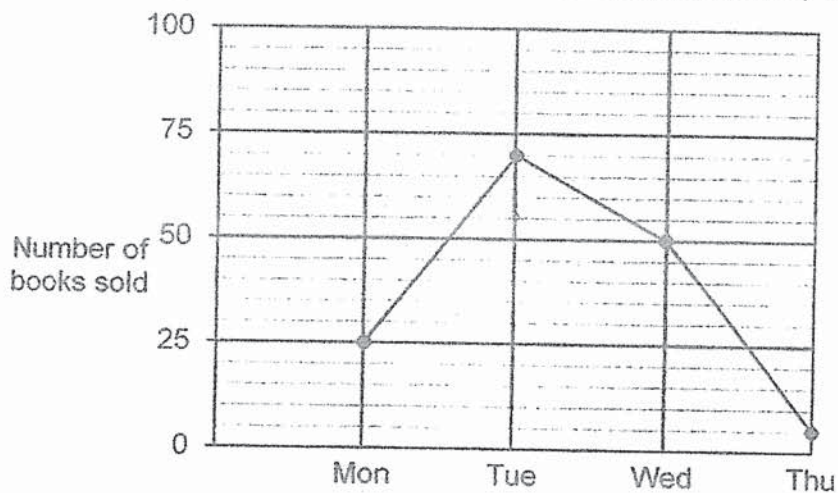

Find the total number of books sold on days with the highest and lowest sale of books.

- (1) 75
- (2) 55
- (3) 120
- (4) 125

11. At first, Kairu covered the base of a rectangular box completely with a layer of unit cubes. He then turned the box to rest on the ground. The unit cubes, when re-arranged, covered 50% of its base. How many cubes can fill the box completely without any gap?

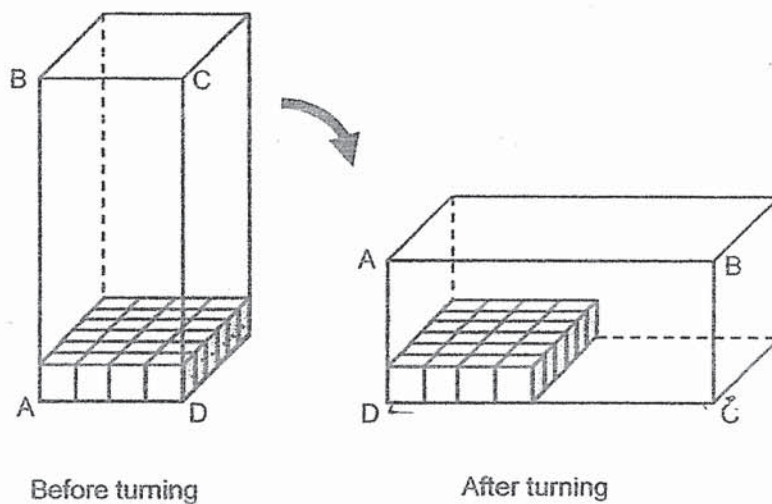

- (1) 144  
(2) 168  
(3) 192  
(4) 384

- 
12. Which one of the following fractions is the furthest from  $\frac{1}{2}$ ?

- (1)  $\frac{1}{8}$   
(2)  $\frac{1}{7}$   
(3)  $\frac{1}{6}$   
(4)  $\frac{1}{5}$



13. Zephyr bought 4 times as many chocolates as sweets. For every 5 chocolates packed into a party bag, he packed 3 sweets. He had 35 chocolates left when all the sweets were completely packed. How many chocolates did he buy at first?
- (1) 15  
 (2) 20  
 (3) 25  
 (4) 60

14. The figure is formed by a semicircle with centre O and 4 straight lines KL, OL, OM and NM. K, L, M and N lie on either the arc or the diameter of the semicircle.

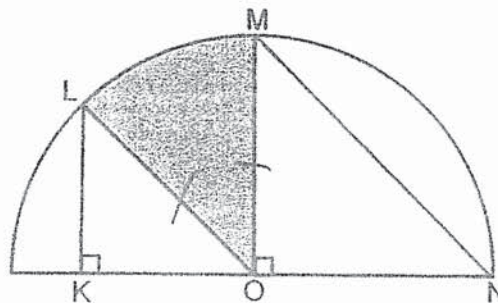

Which of the following statement(s) is/are true?

- Statement A : Line NM is equal to the radius of the semicircle.  
 Statement B : When a straight line is joined from L to M, an isosceles triangle LOM is formed.  
 Statement C : The area of the shaded part LOM is greater than the area of unshaded part KLO.

- (1) A only  
 (2) C only  
 (3) A and B only  
 (4) B and C only



15. James bought a packet of flour to make cakes. He used an equal amount of flour for each cake. After he had used the flour to make 3 cakes,  $\frac{3}{4}$  of the packet of flour was left. He went on to bake another 5 cakes and had 1400 g of the flour left. How much flour was used for each cake?

- (1) 350 g
- (2) 700 g
- (3) 2800 g
- (4) 4200 g

---

END OF BOOKLET A





**CATHOLIC HIGH SCHOOL**  
**PRELIMINARY EXAMINATION (2022)**  
**PRIMARY SIX**  
**MATHEMATICS**  
**PAPER 1**  
**(BOOKLET B)**

Name : \_\_\_\_\_ ( )

Class : Primary 6 \_\_\_\_\_

Date : 22 August 2022

Total time for Booklet A and B : 1 hour

15 questions

25 marks

Parent's signature : \_\_\_\_\_

BOOKLET A	20
BOOKLET B	25
<b>Total Marks</b>	<b>45</b>

**INSTRUCTIONS TO CANDIDATES**

Do not turn over this page until you are told to do so.

Follow all instructions carefully.

Answer all questions.

Write your answers in this booklet.

The use of calculators is **NOT** allowed.

This booklet consists of 9 printed pages and 1 blank page.

Questions 16 to 20 carry 1 mark each. Write your answers in the spaces provided. For questions which require units, give your answers in the units stated. All diagrams are not drawn to scale. (5 marks)

Do not write in this space

16. Round 29 947 to the nearest hundred.

Ans: \_\_\_\_\_

17. Find the value of  $6 \div \frac{3}{5}$

Ans: \_\_\_\_\_

18. Measure and write down the size of  $\angle m$  in the figure.

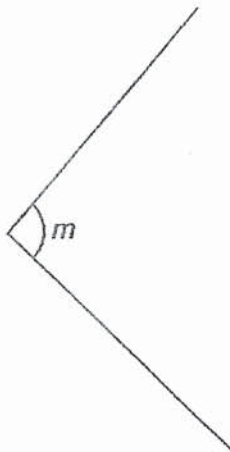

Ans: \_\_\_\_\_ °

19. Find the value of  $2 - \frac{1}{4} - \frac{1}{3}$ .  
Leave your answer as a mixed number.

Do not write  
in this space

Ans: \_\_\_\_\_

20. The figure shows half of a symmetric figure. Draw lines to complete the symmetric figure with the dotted line AB as the line of symmetry.

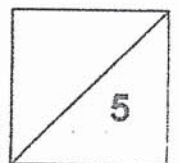
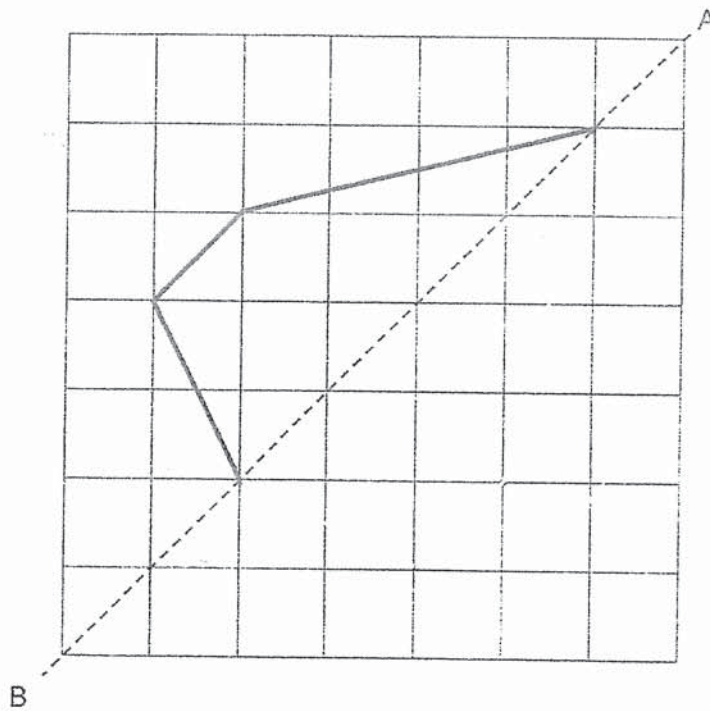

Total marks for questions 16 to 20

3

Go on to the next page

Questions 21 to 30 carry 2 marks each. Show your working clearly and write your answers in the spaces provided. For questions which require units, give your answers in the units stated. All diagrams are not drawn to scale.

(20 marks)

Do not write  
in this space

21. Jai and Kyle entered a gym at 6.30 p.m. Jai left 2 h 30 min later. Kyle left 20 min earlier than Jai. At what time did Kyle leave the gym?  
Give your answer in 24-hour clock format.

Ans: \_\_\_\_\_

22. Molly is 1.74 m tall. She is 7 cm taller than her brother.  
What is her brother's height in metres?

Ans: \_\_\_\_\_ m



23. What is the price of the tennis racket after discount?



Do not write  
in this space

Ans: \$ \_\_\_\_\_

24. The figure below shows a semicircle of diameter 14 cm.  
What is the area of the figure? Take  $\pi = \frac{22}{7}$

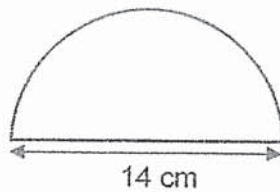

Ans: \_\_\_\_\_ cm<sup>2</sup>

25. The shaded figure below is formed using 3 different squares and a triangle. The perimeter of the triangle is 24 cm. What is the perimeter of the shaded figure?

Do not write  
in this space

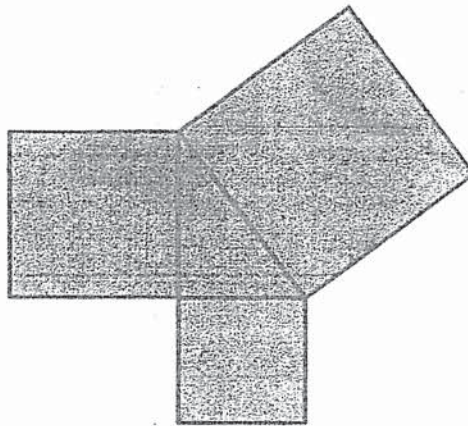

Ans: \_\_\_\_\_ cm

26. 9 pupils took turns to play 6 Rubik's cubes during a 30-min recess. At any one time, 6 pupils played the cubes while the other 3 waited. Each had the same amount of playing time. How many minutes did each pupil play on the Rubik's cube?



Rubik's cube

Ans: \_\_\_\_\_ min

27. Lily bought some stickers based on the charges shown below.

First 10 stickers	\$7
Every additional sticker	50¢
Get 2 additional stickers free for every purchase of 30 stickers	

She paid \$17 for the stickers. How many stickers did she get in all?

Ans: \_\_\_\_\_

Do not write  
in this space

28. A cuboid was cut along the dotted line into two smaller cuboids as shown below. The shaded face is a square and the volume of cuboid S is  $500 \text{ cm}^3$  more than that of cuboid T. What is the height of cuboid T?

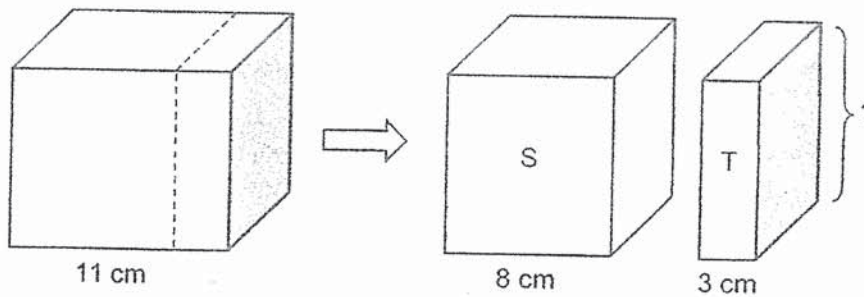

Ans : \_\_\_\_\_ cm

29. Mrs Lee wanted to buy 9 boxes of mooncakes but she was short of \$28. She bought 7 boxes of mooncakes and had \$22 left. How much money did she have at first?

Do not write in this space

Ans: \$ \_\_\_\_\_

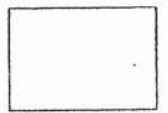

30. A parallelogram ABCD is drawn on a square grid inside a box.

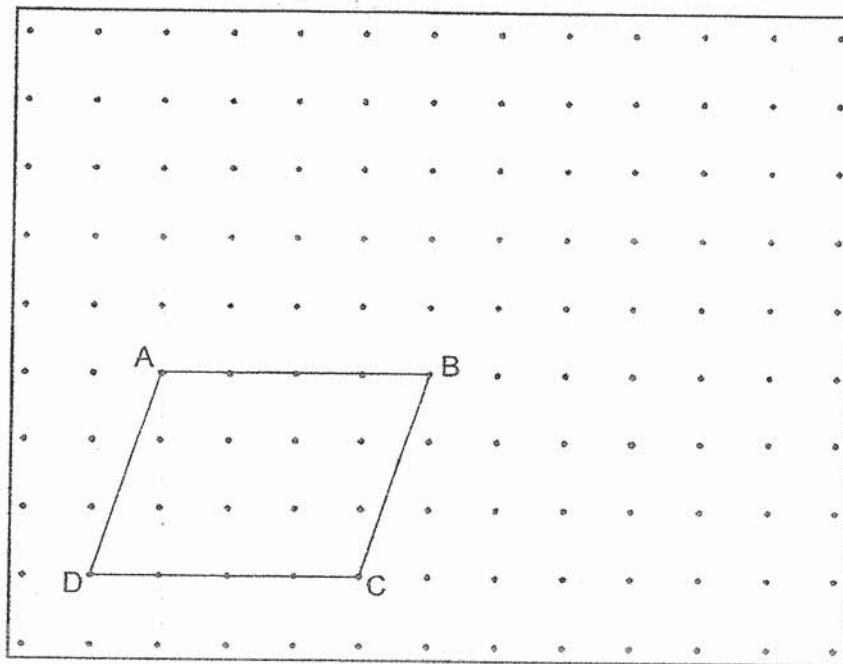

Do not write  
in this space

By joining the dots on the grid with straight lines,

- (a) draw a triangle ACE such that AE is parallel to CB and it has the same area as triangle ABC.
- (b) draw a triangle BCF such that  $\angle CBF$  is a right angle and  $BC = BF$ . Triangle BCF must not overlap with the parallelogram ABCD.



Total marks for questions 21 to 30  
END OF BOOKLET B  
END OF PAPER 1

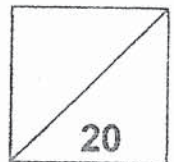



**CATHOLIC HIGH SCHOOL**  
**PRELIMINARY EXAMINATION (2022)**  
**PRIMARY SIX**  
**MATHEMATICS**  
**PAPER 2**

Name : \_\_\_\_\_ ( )

Class : Primary 6 \_\_\_\_\_

Date : 22 August 2022

Total time : 1 hour 30 min

17 questions

55 marks

Parent's signature : \_\_\_\_\_

PAPER 1 BOOKLET A	20
PAPER 1 BOOKLET B	25
PAPER 2	55
Total Marks	100

**INSTRUCTIONS TO CANDIDATES**

Do not turn over this page until you are told to do so.

Follow all instructions carefully.

Answer all questions.

Write your answers in this booklet.

The use of an approved calculator is expected, where appropriate.

This booklet consists of 16 printed pages.



Questions 1 to 5 carry 2 marks each. Show your working clearly in the space below each question and write your answers in the spaces provided. For questions which require units, give your answers in the units stated. All diagrams are not drawn to scale. (10 marks)

Do not write  
in this space

1. Charlie needs 100 pieces of string, each of length 80 cm. The string is sold in rolls of 500 cm each. What is the least number of rolls of string that Charlie needs to buy?

Ans: \_\_\_\_\_

2. The table shows the number of sit-ups Ramesh did last week.

Day	Number of sit-ups
Monday to Friday	$3p$ per day
Saturday	60
Sunday	$4p - 8$

What was the total number of sit-ups Ramesh did last week?  
Give your answer in terms of  $p$  in the simplest form.

Ans: \_\_\_\_\_

3. The nets drawn for the solids below are incomplete and missing two faces. For each net, shade two faces so that the net can be folded to form the respective solids.

Do not write in this space

(a)

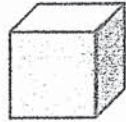

Cube

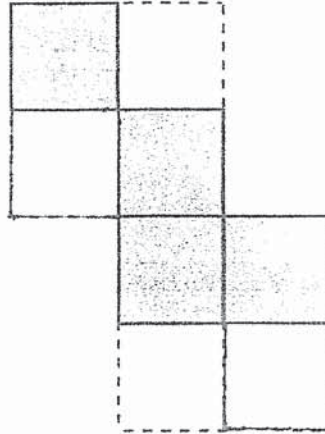

[1]

(b)

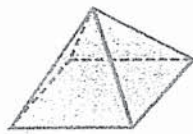

Pyramid

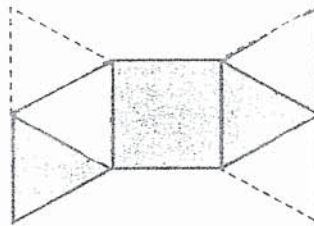

[1]

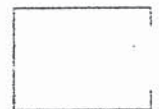

4. A roll of ribbon can be cut equally into 9 short ribbons or 5 long ribbons. A short ribbon is 24 cm shorter than a long ribbon. What is the length of a short ribbon?

Do not write  
in this space

Ans: \_\_\_\_\_ cm

- 5 Ben and Kai cycled in three races in a tournament. Their cycling times for the races are shown in the table below.

Race	Cycling Time (min)	
	Ben	Kai
1 <sup>st</sup>	23	21
2 <sup>nd</sup>	22	29
3 <sup>rd</sup>	24	16

Both calculated their average cycling time for the three races. Who had a faster average cycling time? What was his average cycling time?

Ans: Name : \_\_\_\_\_

Average cycling time: \_\_\_\_\_ min

For questions 6 to 17, show your working clearly in the space provided for each question and write your answers in the spaces provided. The number of marks available is shown in brackets [ ] at the end of each question or part-question. (45 marks)

Do not write in this space

6. A group of children was asked to choose one sandwich from Tuna, Sardine, Egg and Cheese. The pie chart represents the children's choices.

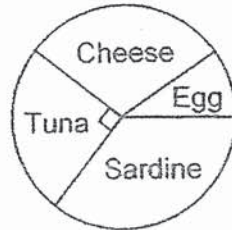

The children's choices are also represented by the bar graph below but the number of children is not shown on the scale. The bar that shows the number of children who chose Cheese is also not drawn.

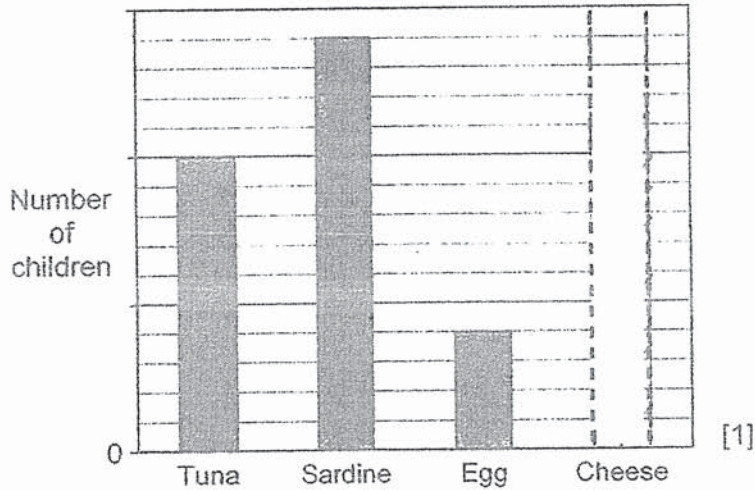

- (a) How many children chose Cheese?  
Draw the bar that represents the number of children who chose Cheese in the bar graph above. [1]
- (b) The number of children who chose Sardine was 56.  
How many children chose Egg? [1]

Ans: (a) \_\_\_\_\_ [1]

(b) \_\_\_\_\_ [1]

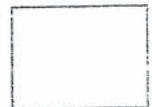

7. In the figure, ABCD is a rhombus and AEB is an equilateral triangle. FBD and EFC are straight lines.  $\angle BDA = 79^\circ$  and  $\angle FCB = 19^\circ$ . Find  $\angle EFD$ .

Do not write  
in this space

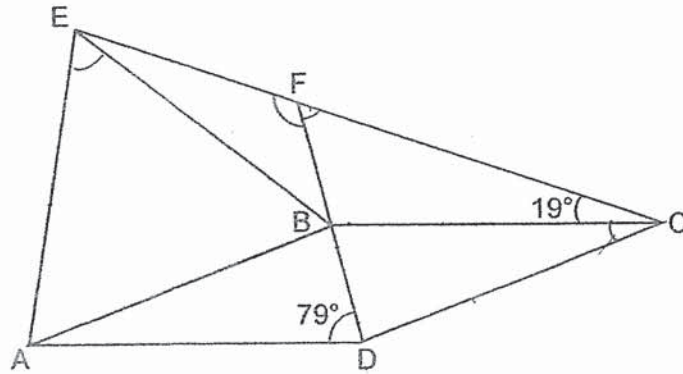

Ans: \_\_\_\_\_ [3]



8. At a bread shop, a customer could buy one additional bun at half its usual price for every 3 buns bought. Petra paid \$16.80 for 12 buns. What was the usual price of one bun?

Do not write  
in this space

Ans: \_\_\_\_\_ [3]

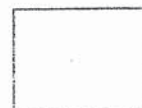



9.

A rectangular paper  $OPQS$  of area  $432 \text{ cm}^2$  is folded along the dotted line  $OQ$  to form the figure  $OSRPQ$  of area  $312 \text{ cm}^2$ .  $RP = 16 \text{ cm}$ . What is the length of  $PQ$ ?

Do not write in this space

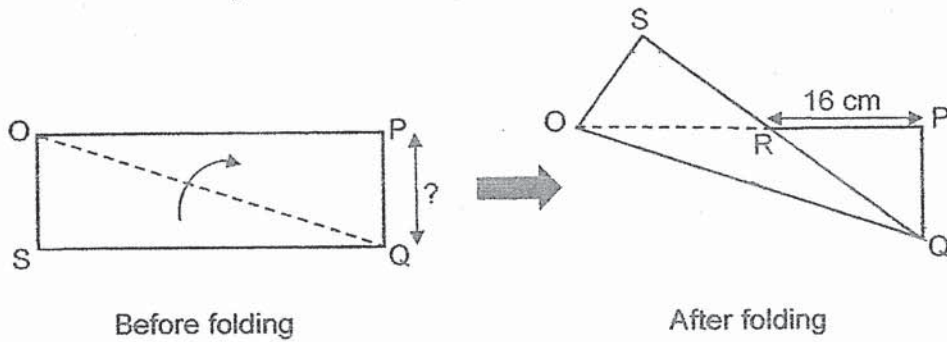

Ans: \_\_\_\_\_ [3]

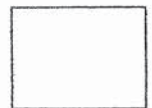

10. In the figure below, BEF is a triangle and BCDE is a trapezium. ABC is a straight line.

Do not write in this space

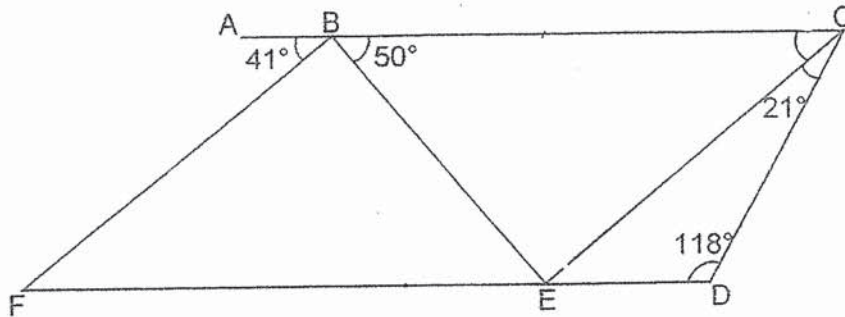

- (a) Find  $\angle BCE$ .

Ans: (a) \_\_\_\_\_ [1]

- (b) The figure above is not drawn to scale. Each of the statements below is either true, false or not possible to tell from the information given. For each statement, put a tick ( $\checkmark$ ) to indicate your answer.

Statement	True	False	Not possible to tell
BCEF is a parallelogram.			
BE is perpendicular to EC.			

[2]



11.

At first, a tank was filled with some water. Tap A was turned on for more water to flow into the tank. After 4 minutes, Tap B was turned on for water to flow out of the tank. Both taps were turned off at the same time when the tank was completely filled without overflowing. The graph below shows the amount of water in the tank over the 18 minutes.

Do not write  
in this space

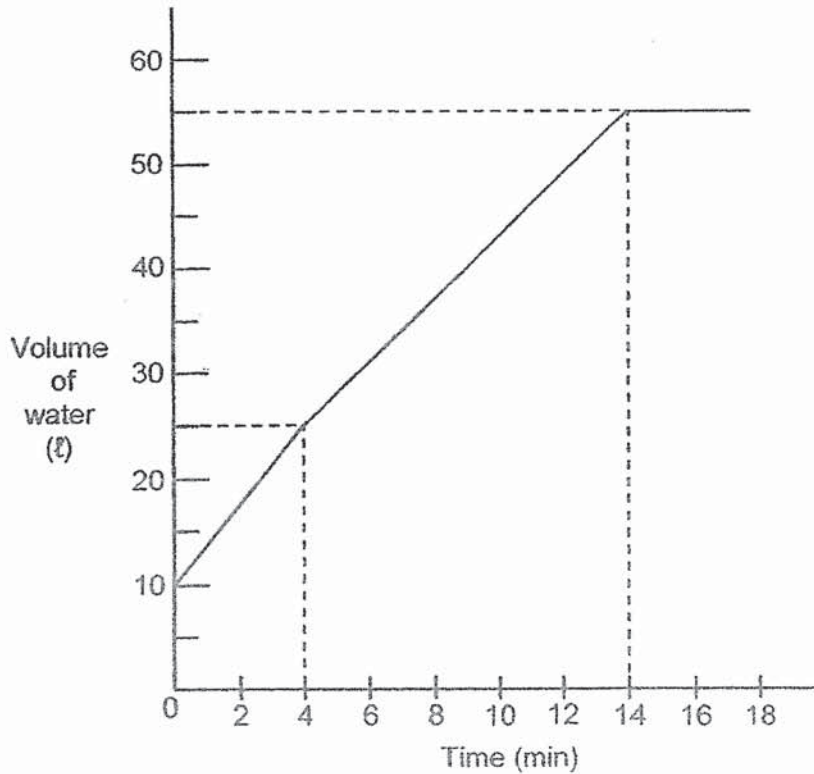

- (a) What fraction of the tank was filled with water at first before Tap A was turned on? Give your answer in the simplest form.
- (b) How many litres of water flowed into the tank per minute before Tap B was turned on?
- (c) From the 4<sup>th</sup> minute to the 14<sup>th</sup> minute, how much water flowed out of the tank?

Ans: (a) \_\_\_\_\_ [1]

(b) \_\_\_\_\_ [1]

(c) \_\_\_\_\_ [2]

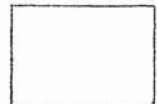

12. Bobby and Fanny started jogging from a park to their houses at the same time. A mall was exactly halfway between their houses. It was also 280 m away from the park as shown below. Bobby jogged at 120 m/min while Fanny jogged at 40 m/min faster than Bobby. Both did not change their speeds throughout and reached their houses at the same time. How far was Bobby's house from the park?

Do not write  
in this space

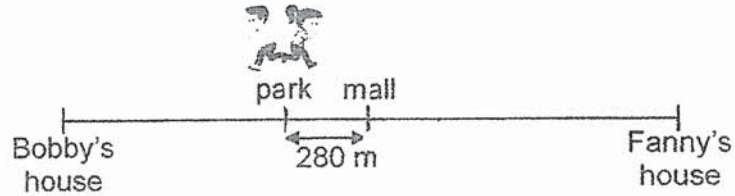

Ans: \_\_\_\_\_ [4]



13. A fruit seller bought some plums. He threw away 152 plums that were damaged. After selling  $\frac{1}{5}$  of the remaining plums, he was left with  $\frac{4}{7}$  of the plums bought. He packed these into large boxes of 12 plums and small boxes of 8 plums. All the boxes were full and there was no left over.

Do not write  
in this space

- (a) How many plums were packed into boxes?  
(b) What was the least number of boxes used by the fruit seller?

Ans: (a) \_\_\_\_\_ [2]

(b) \_\_\_\_\_ [2]

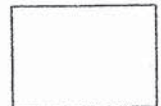

14.

A funfair was decorated with red and white balloons. At first, there were 19 more white balloons than red balloons. 25% of the white balloons burst. More red balloons were added so that there were 26 more red balloons than white balloons. In the end, there was a total of 170 red and white balloons.

Do not write  
in this space

- (a) How many red balloons were there in the end?
- (b) What was the percentage increase in the number of red balloons?  
Round your answer to 1 decimal place.

Ans: (a) \_\_\_\_\_ [1]

(b) \_\_\_\_\_ [3]

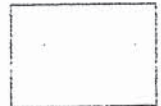



15. A metal box filled completely with 30 identical bolts weighs 1.18 kg. The same metal box when filled completely with 70 identical nuts weighs 1.54 kg. The ratio of the mass of a bolt to that of a nut is 5 : 3.

Do not write  
in this space



a bolt



a nut

- (a) How many nuts have the same total mass of 3 bolts?  
(b) What is the mass of the metal box?

Ans: (a) \_\_\_\_\_ [1]

(b) \_\_\_\_\_ [3]

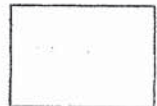

16. The figure is formed by 3 identical small quarter circles and 3 identical big quarter circles.

Do not write  
in this space

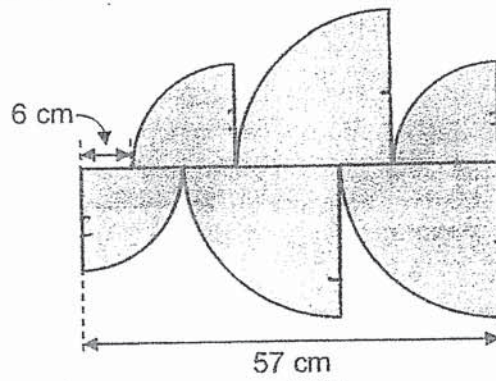

- (a) Find the <sup>radius</sup> ~~diameter~~ of the small <sup>quarter</sup> circle.
- (b) Find the perimeter of the shaded figure.
- (Take  $\pi = 3.14$ )

Ans: (a) \_\_\_\_\_ [2]

(b) \_\_\_\_\_ [3]

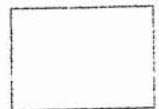

17. Raju used white and grey squares to form the following patterns as shown below.

Do not write in this space



Figure 1



Figure 2

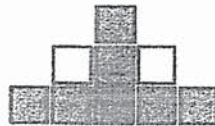

Figure 3

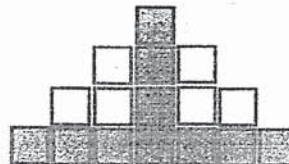

Figure 4

The table below shows the number of white and grey squares in each figure.

Figure Number	1	2	3	4	5
Number of white squares	0	0	2	6	
Number of grey squares	1	4	7	10	

[1]

- (a) Fill in the table for Figure 5.
- (b) What is the total number of squares in Figure 40?
- (c) How many more white squares than grey squares are used in Figure 40?

Ans: (b) \_\_\_\_\_ [1]

(c) \_\_\_\_\_ [3]

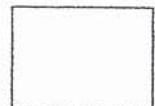

END OF PAPER 2



## ANSWER KEY

YEAR : 2022  
 LEVEL : PRIMARY 6  
 SCHOOL : CATHOLIC HIGH  
 SUBJECT : MATHEMATICS  
 TERM : PRELIMINARY

### BOOKLET A (PAPER 1)

Q1	4	Q2	1	Q3	2	Q4	2	Q5	4
Q6	3	Q7	1	Q8	2	Q9	4	Q10	1
Q11	3	Q12	1	Q13	4	Q14	4	Q15	4

### BOOKLET B (PAPER 1)

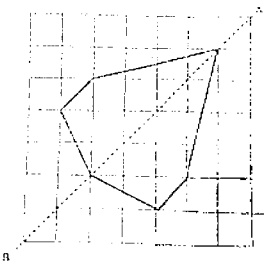
Q16	29900	Q17	10
Q18	$94^\circ$	Q19	$2\frac{3}{12} - \frac{4}{12} = 1\frac{12}{12} - \frac{3}{12} - \frac{4}{12} = 1\frac{9}{12} = 1\frac{3}{4}$
Q20		Q21	2040
Q22	$174 - 7 = 167$ ANS : 1.67m	Q23	$\frac{89}{100} \times 90 = 8.9 \times 9 = 80.1$ ANS : \$80.10
Q24	$\frac{1}{2} \times \frac{22}{7} \times 7 \times 7 = 77$ ANS : $77\text{cm}^2$	Q25	$24 \times 3 = 72\text{cm}$
Q26	$6 \times 30 = 180\text{ min}$ $180 \div 9 = 20\text{ min}$	Q27	$17 - 7 = 10$ $10 \div 0.5 = 20$ $20 + 10 + 2 = 32$
Q28	$8 - 3 = 5$ $500 \div 5 = 100$ $\sqrt{100} = 10$ ANS : 10cm	Q29	$22 + 28 = 50$ $9 - 7 = 2$ $2b = \$50$ $7b = \frac{50}{2} \times 7$ $= 25 \times 7 = 175$ $175 + 22 = 197$ ANS : \$197

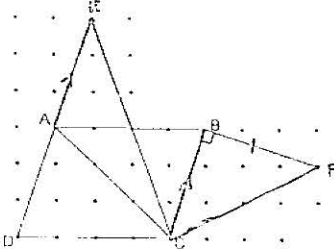
Q30		
-----	---	--

PAPER 2

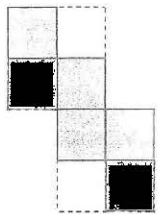
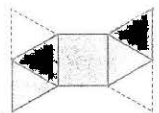
Q1	<p>No of string from 1 roll  <math>= 500 \div 80 = 6R20</math>  <math>100 \div 6 = 16R4 \approx 17</math>  ANS : 17</p>	Q2	$3p \times 5 + 60 + 4p - 16$ $= 15p + 4p + 60 - 16$ $= 19p + 44$
Q3	<p>a)</p>  <p>b)</p> 	Q4	$24 \times 5 = 120$ $9 - 5 = 4$ $120 / 4 = 30$ Ans: 30 cm
Q5	$\frac{23+22+24}{3} : \frac{21+29+16}{3}$ $69/3 : 66/3$ $23 : 22$ <p>Ans: Name: Kai  Average cycling time: 22 min</p>	Q6	<p>a) <math>10 \times 4 - 14 - 4 - 10</math>  <math>= 40u - 18u - 10u</math>  <math>= 12u</math></p> <p>b) <math>56 / 14 \times 4 = 16</math></p>
Q7	$\angle EFD = 180^\circ - 60^\circ = 120^\circ$	Q8	$1 \text{ set} = 4 \text{ buns} = 7u$ $12 / 4 = 3$ $3 \times 7u = 21u$ $16.8 / 21 = 0.8$ $0.8 \times 2 = 1.6$ Ans: \$1.60

Q9	$\Delta OSQ = 432 \div 2 = 216$ $\Delta RPQ = 312 - 216 = 96$ $\frac{1}{2} \times 16 \times H = 96$ $\frac{96 \times 2}{16} = 12$ ANS : 12cm	Q10	a) $\angle BCE = 180^\circ - 21^\circ = 118^\circ$ $= 41^\circ$ b) <table border="1" data-bbox="901 302 1372 593"> <thead> <tr> <th>Statement</th> <th>True</th> <th>False</th> <th>Not possible to tell</th> </tr> </thead> <tbody> <tr> <td>BCEF is a parallelogram</td> <td></td> <td></td> <td>✓</td> </tr> <tr> <td>BE is perpendicular to EC</td> <td></td> <td>✓</td> <td></td> </tr> </tbody> </table>	Statement	True	False	Not possible to tell	BCEF is a parallelogram			✓	BE is perpendicular to EC		✓	
Statement	True	False	Not possible to tell												
BCEF is a parallelogram			✓												
BE is perpendicular to EC		✓													
Q11	a) $\frac{10}{55} = \frac{2}{11}$ b) 4 min $\rightarrow$ 15 litre $15 \text{ litre} / 4 = 4 \frac{3}{4} \text{ litre/min}$ c) $14 - 4 = 10$ $10 \times 3 \frac{3}{4} = 37 \frac{1}{2} \text{ litre}$ $37 \frac{1}{2} - 30 = 7 \frac{1}{2} \text{ litre}$	Q12	$280 \times 2 = 560$ (Fanny) $560 \div 40 = 14$ $120 \times 14 = 1680 \text{cm}$												
Q13	a) $152 / 2 \times 4 = 304$ b) $304 / 12 = 25 \text{ R } 4$ $24 \text{ large box} + 16 \text{ plums}$ $24 + 2 = 26$	Q14	a) $75\%w + 75\%w + 26 = 170$ $150\%w = 144$ $75\%w = 144/150 \times 75 = 72$ $72 + 26 = 98$  b) In the end, $w = 72$ $75\%w = 72$ $1\%w = 72/75$ $100\%w = 72/75 \times 100 = 96$ $96 - 19 = 77$ $98 - 77 = 21$ $21/77 \times 100\% \Rightarrow 27.3\%$												
Q15	a) $3 \times 5 = 15$ $15 \div 3 = 5$ b) $0.36 / 12 \times 30 = 0.9$ $1.18 - 0.9 = 0.28 \text{ kg}$	Q16	a) $6 \times 2 = 12$ $57 - 12 = 45$ $45 \div 3 = 15$ ANS : 15cm  b) $1/4 \times 3 \times 3.14 \times 30 + 1/4 \times 3 \times 3.14 \times 42 = 169.56$ $169.56 + 45 + 63 + 6 = 283.56 \text{cm}$ Ans: 283.56 cm												



Q17

a)

Figure number	1	2	3	4	5
Number of white square	0	0	2	6	12
Number of grey square	1	4	7	10	13

ANS : 12 (white square)  
13 (Grey square)

b)  $40 \times 40 = 1600$

c)  $(\text{Fig no}-1) \times 3 + 1$   
 $(40 - 1) \times 3 + 1$   
 $39 \times 3 + 1$   
118 (Grey)  
 $1600 - 118 = 1482$  (white)  
 $1482 - 118 = 1364$   
Ans: 1364

b  
END