

RED SWASTIKA SCHOOL
 2022 MID-YEAR EXAMINATION
 ENGLISH LANGUAGE – PAPER 3
 LISTENING COMPREHENSION
 PRIMARY 6

Name : _____ () Marks : ____ / 20

Class : Pr 6 / _____

Date : 22 April 2022

Parent's Signature : _____

SHADE THE CORRECT OVAL (1, 2 OR 3) ON THE OPTICAL ANSWER SHEET.

TEXT 1

1 Which picture shows the Innovate Builder Kit?

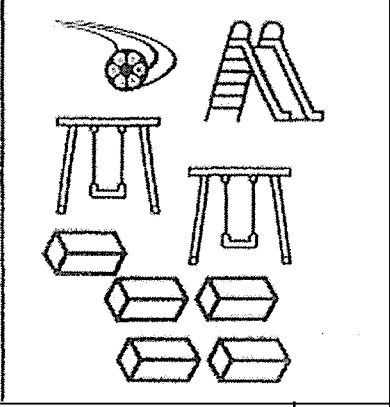
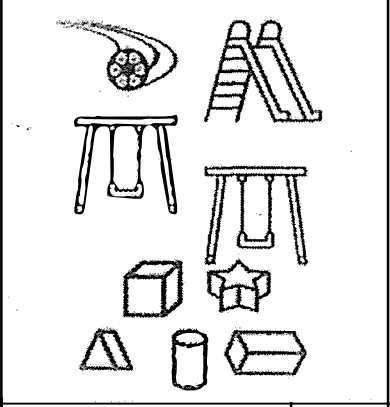
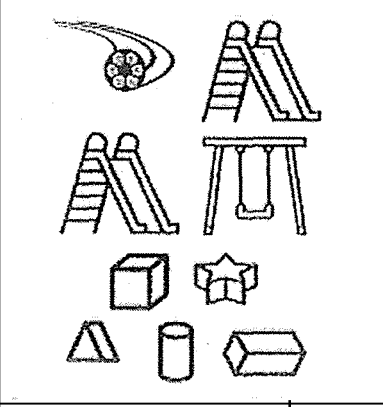
		
1	2	3

2 Which picture shows the items a person will receive on purchasing an Innovate Builder Kit?

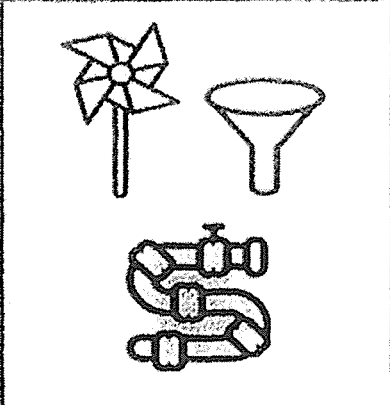
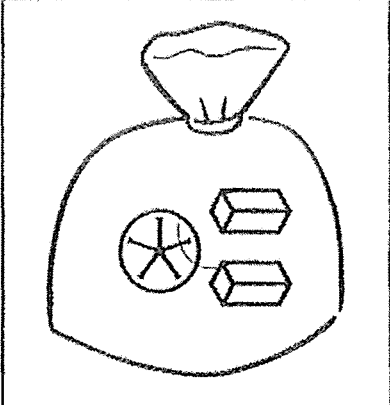
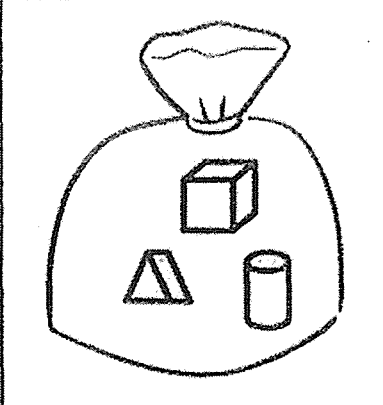
		
1	2	3

TEXT 2

3 Which line shows the route that Crystal will take from her home to the swimming pool?

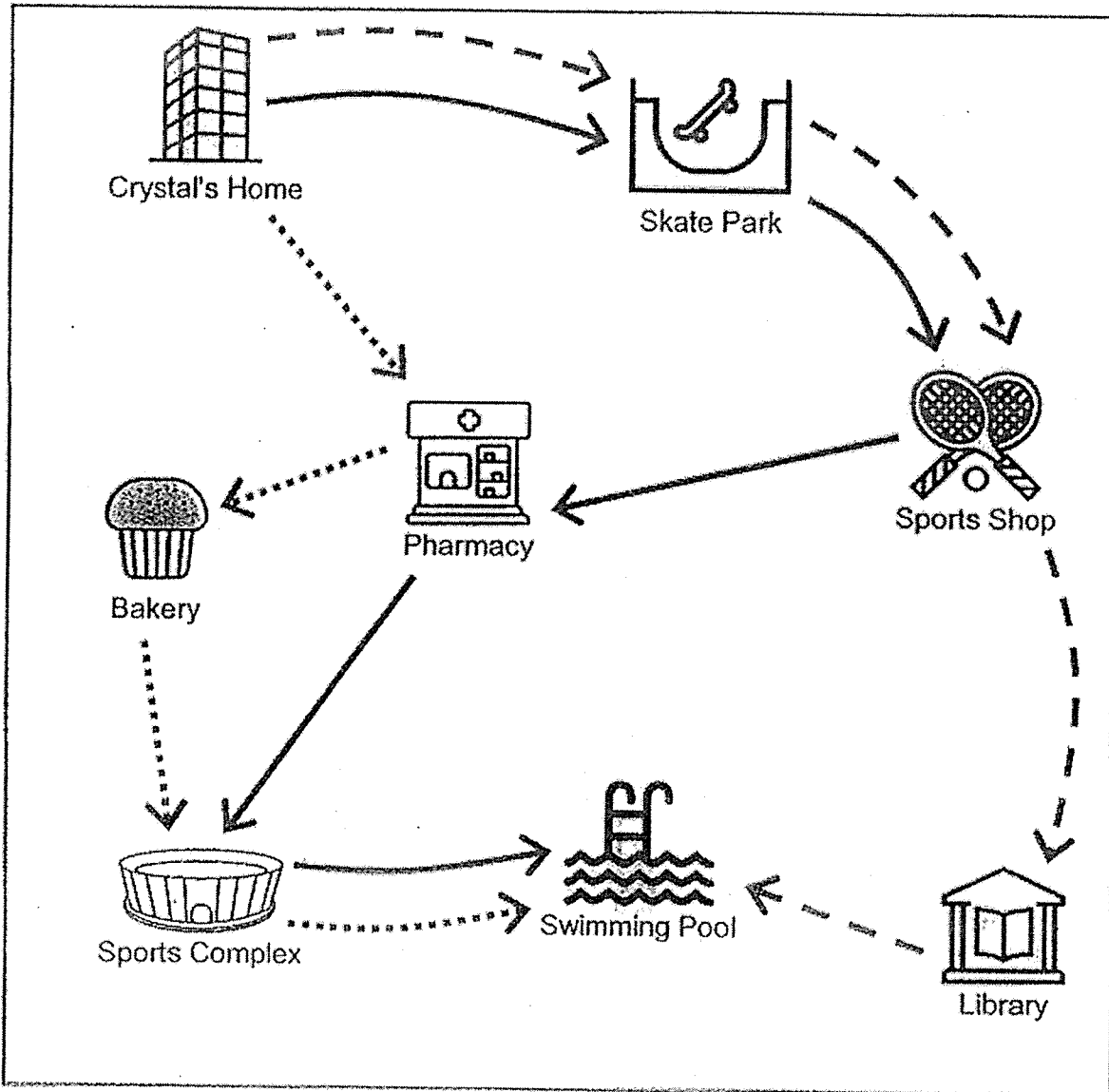

(1) 

(2) 

(3) 

4 Which picture shows the items that Kevin picks up before going for a swim?

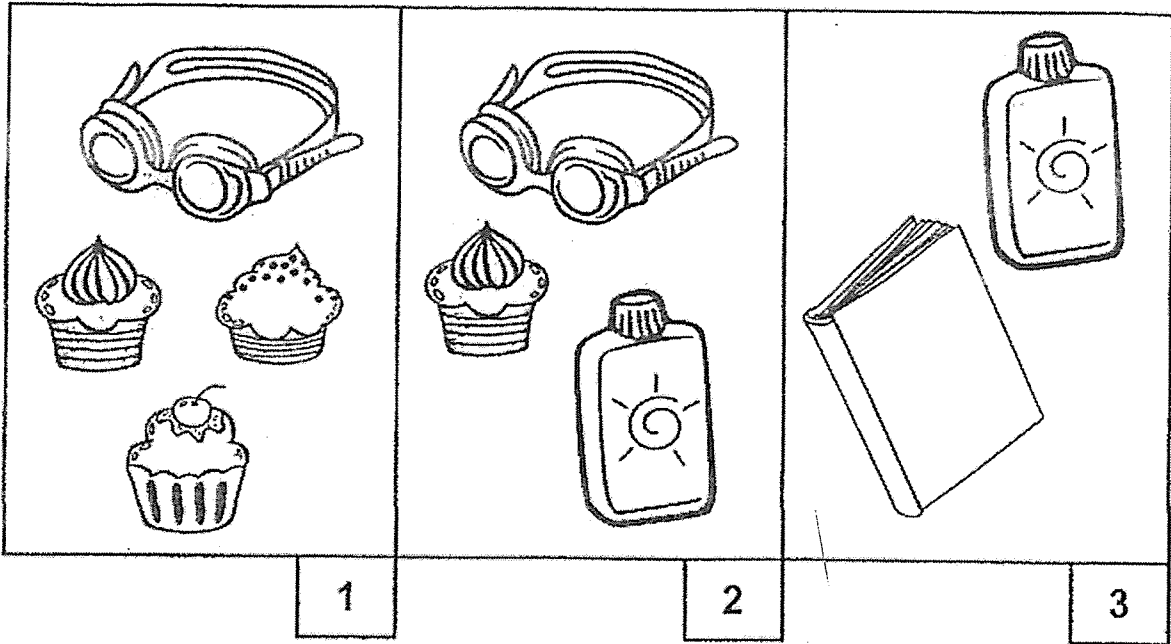

TEXT 3

5 Which picture represents the play that nearly all the students enjoyed most?

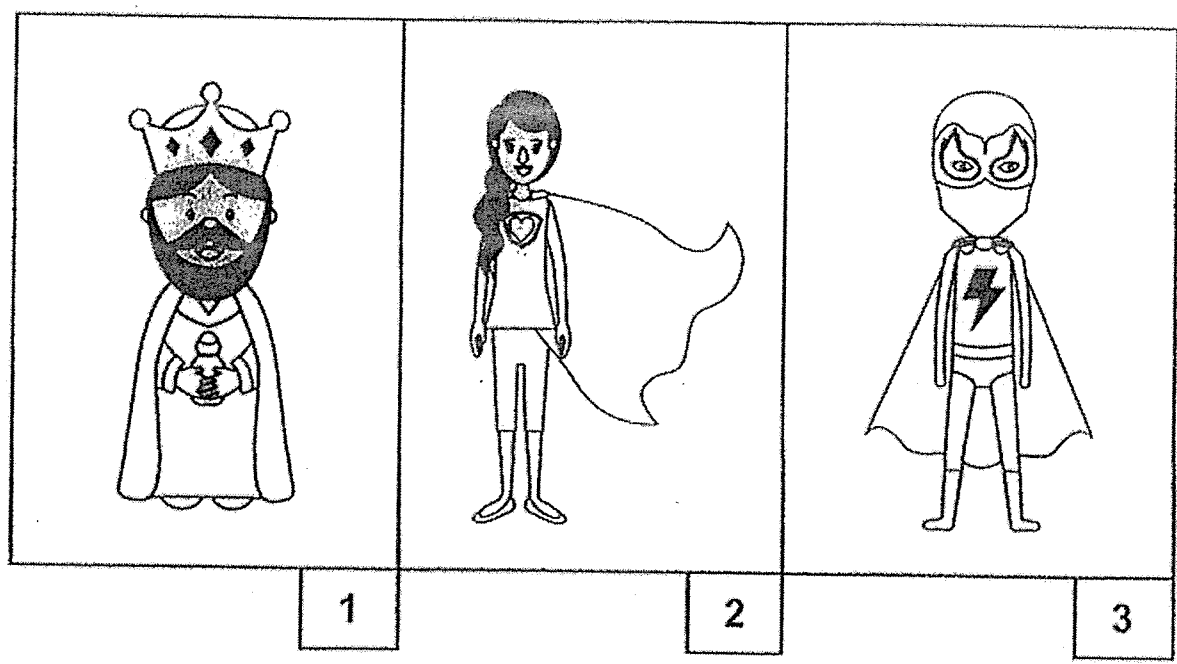

6 Where will the students go when it is their turn to audition for a part?

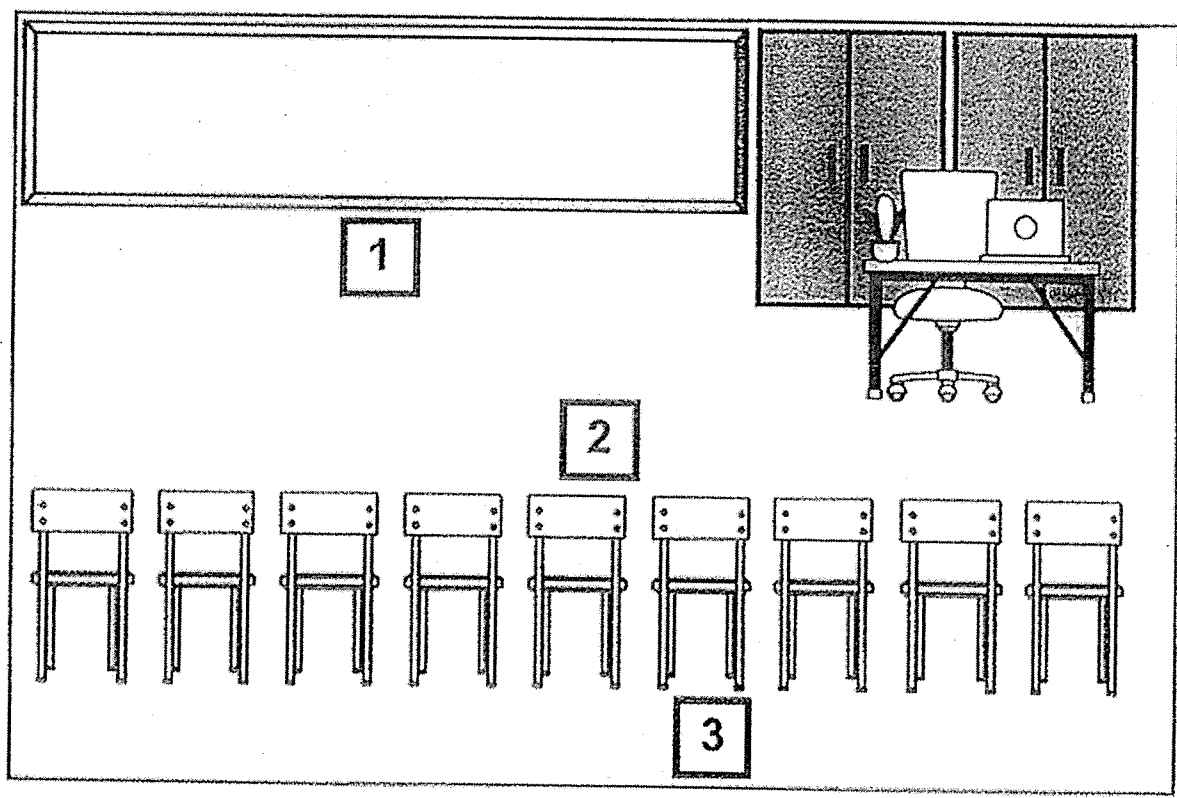

7. Which picture shows the teacher's instructions for preparing for the auditions?

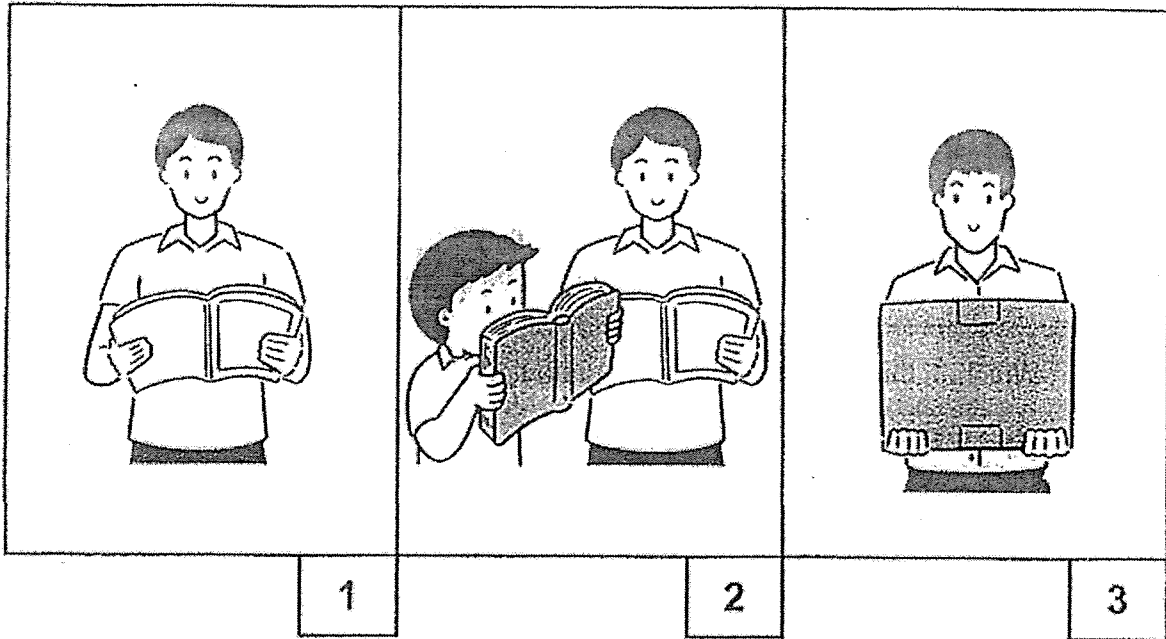

TEXT 4

- 8 According to the extract, a person can recycle by _____.
- (1) not using raw materials
 - (2) conserving natural resources
 - (3) putting used items in sorting bins
- 9 Which of the following statements about recycling is correct?
- (1) Clothing can be recycled.
 - (2) All items made of plastic can be recycled.
 - (3) Items to be recycled must be in good condition.
- 10 The extract advises people who want to play a part in saving the environment to _____.
- (1) try selling used items
 - (2) reuse items whenever possible
 - (3) donate food items to those in need

TEXT 5

11 According to Lucy, she found the first few years in school tough because she _____.

- (1) was not good at any of the subjects
- (2) could not figure out how to solve her problems
- (3) did not know why she was having difficulty with her studies

12 What stopped Lucy from telling her parents about her struggles?

- (1) She felt ashamed.
- (2) She was naturally shy.
- (3) She did not want to get scolded.

13 How did Lucy overcome the difficulties that she faced in school?

- (1) She avoided difficult questions in class.
- (2) She asked her teachers' questions in class.
- (3) She made the effort to answer questions in class.

TEXT 6

- 14 The students were surprised because _____.
- (1) they had come up with many different answers
 - (2) their teacher had asked them to make rough guesses
 - (3) the weight of the jar was not as significant as they thought
- 15 The teacher used the activity to show that _____.
- (1) the more support the jar had, the lighter it felt
 - (2) the heavier the jar was, the more support it needed
 - (3) the weight of the jar was determined by the support it had
- 16 How did the students feel when they first heard the teacher's explanation?
- (1) hopeful
 - (2) bewildered
 - (3) enlightened
- 17 What can we learn from what the teacher said at the end of the story?
- (1) We should always solve our own problems.
 - (2) We should look for realistic ways to solve our problems.
 - (3) We should give others a chance to solve our problems for us.

TEXT 7

18 Which of the following statements about the campaign is true?

- (1) It was launched by a health food company.
- (2) It aims to prevent health problems from increasing.
- (3) It includes advertisements for healthy food and drink.

19 Based on the news report, Tiffany initially thought _____.

- (1) the salads and fruit juices would not be well received
- (2) she would not get to sample the salads and fruit juices
- (3) the vending machine would not serve the salads and fruit juices

20 What is the news report mainly about?

- (1) why people should watch what they eat
- (2) how a company plans to raise health awareness
- (3) a machine that offers healthy food and drink options





RED SWASTIKA SCHOOL
2022 MID-YEAR EXAMINATION
ENGLISH LANGUAGE – PAPER 1
SITUATIONAL/CONTINUOUS WRITING
PRIMARY 6

Name : _____ ()

Class : Primary 6 / _____

Date : 5 May 2022

Duration of Paper: 1 h 10 min

Note:

1. Do not open this booklet until you are told to do so.
2. Read carefully the instructions given at the beginning of each question.
3. In this booklet, you should have the following:
 - a. Page 1 to Page 3
 - b. Questions 1 and 2

QUESTION	OBTAINED	POSSIBLE
SITUATIONAL WRITING		15
CONTINUOUS WRITING		40
TOTAL		55

Parent's Signature : _____

Instructions to candidates:

There are TWO parts to this paper: Part 1 and Part 2. Answer both questions.

Part 1: Situational Writing (15 marks)

Study the following pictures carefully.

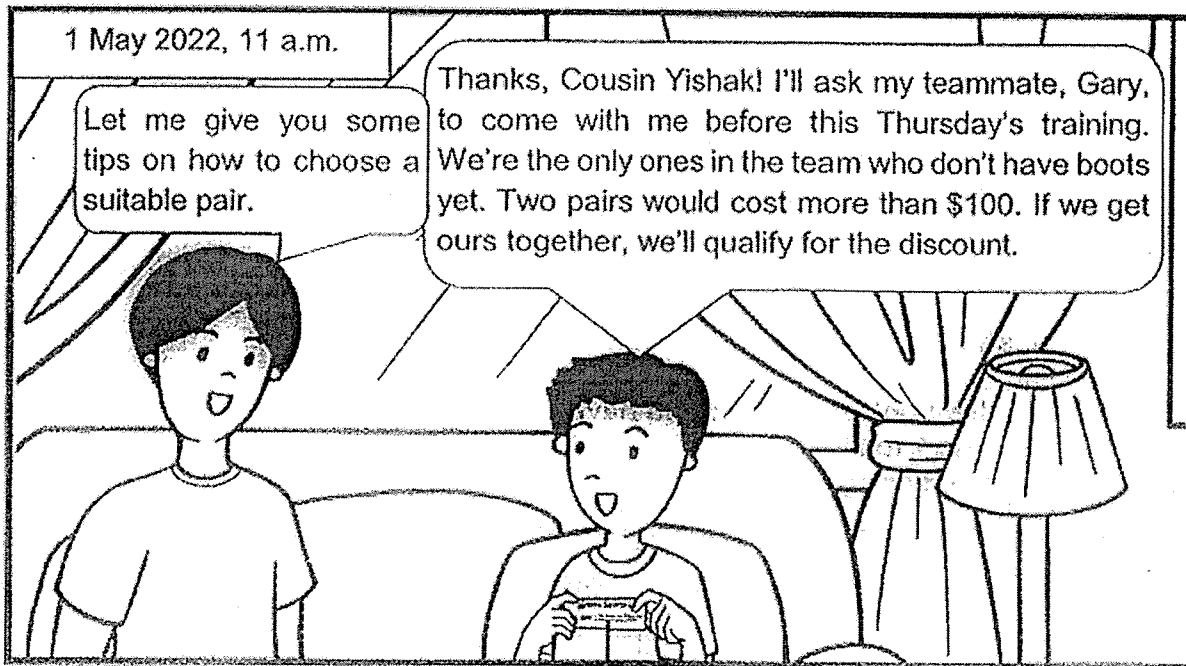

 **Elite Sports**

20%OFF

- ✓ Valid from 1 to 22 May 2022
- ✓ Minimum spend of \$100

Your Task

Imagine you are Amir.

Write an email to your teammate, Gary, inviting him to shop for soccer boots with you.

You are to refer to the pictures and information on page 1 for your email.

In your email, include the following key information:

- when and where you want to shop for soccer boots
- why you thought of asking him to go with you
- two reasons why he should shop for soccer boots with you
- the last day to use the voucher

You may reorder the points. Remember to write in complete sentences.

Part 2: Continuous Writing (40 marks)

Write a composition of at least 150 words about **kicking a bad habit**.

The pictures are provided to help you think about the topic.

Your composition should be based on one or more of these pictures.

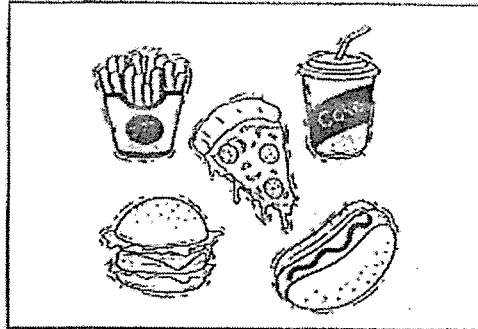

Consider the following points when you plan your composition.

- What was the bad habit?
- What was the reason for kicking the bad habit?

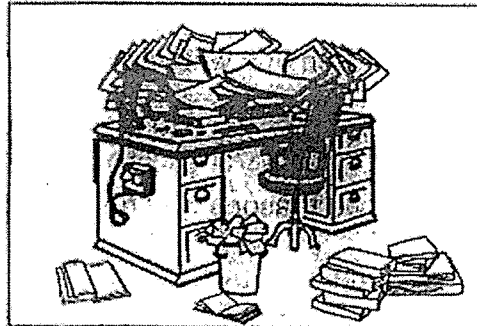

You may use the points in any order and include other relevant points as well.

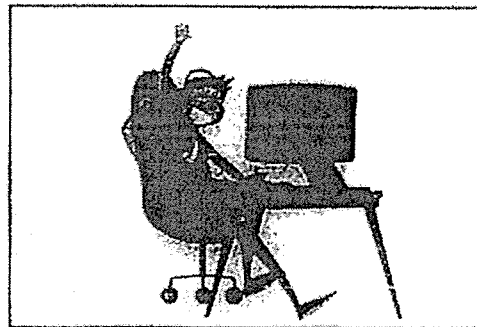



RED SWASTIKA SCHOOL
2022 MID-YEAR EXAMINATION
ENGLISH LANGUAGE – PAPER 2
LANGUAGE USE AND COMPREHENSION
PRIMARY 6

Name : _____ ()

Class : Primary 6 / _____

Date : 10 May 2022

BOOKLET A

28 Questions

28 Marks

Duration of Paper: 1 h 50 min

Note:

1. Do not open this booklet until you are told to do so.
2. Read carefully the instructions given at the beginning of each part of the booklet.
3. Do not waste time. If a question is difficult for you, go on to the next one.
4. Check your answers thoroughly and make sure you attempt every question.
5. In this booklet, you should have the following:
 - a. Page 1 to Page 9
 - b. Questions 1 to 28

For each question from 1 to 10, shade your answer (1, 2, 3 or 4) on the Optical Answer Sheet.
(10 marks)

- 1 Rina blushed when she was praised. She was not accustomed _____ receiving compliments from her peers
- (1) in
 - (2) to
 - (3) by
 - (4) with
- 2 "_____ glass of warm milk would make you feel better. Would you like one?" asked Father.
- (1) A
 - (2) An
 - (3) Any
 - (4) The
- 3 _____ Alice _____ Sarah ate the noodles. They were already full as they had eaten earlier.
- (1) Either... or
 - (2) Both... and
 - (3) Neither...nor
 - (4) Whether... or
- 4 My parents will be taking my sister and _____ to the beach this weekend.
- (1) I
 - (2) me
 - (3) mine
 - (4) myself
- 5 The number of dengue cases _____ increasing. We must take steps to prevent mosquito breeding.
- (1) is
 - (2) are
 - (3) was
 - (4) were

- 6 Mrs Prasad gave her son so _____ ideas that he had a hard time choosing his favourite.
- (1) few
 - (2) little
 - (3) many
 - (4) much
- 7 "Ahmad can be the Class Monitor. He's been a role model for his peers, _____?" said the teacher.
- (1) isn't he
 - (2) can't he
 - (3) hasn't he
 - (4) wasn't he
- 8 "I remember _____ an advertisement about the newest mobile phone in town. I would love to check it out," Sally told her friend.
- (1) see
 - (2) saw
 - (3) seen
 - (4) seeing
- 9 Wei Chong thinks that he _____ still attend the basketball tryouts although he did not feel like going.
- (1) can
 - (2) shall
 - (3) could
 - (4) should
- 10 "_____ you have ordered the exact amount of food we needed? Now we have a lot of leftovers!" grumbled Mother.
- (1) Can't
 - (2) Won't
 - (3) Couldn't
 - (4) Wouldn't

For each question from 11 to 15, shade your answer (1, 2, 3 or 4) on the Optical Answer Sheet.

(5 marks)

- 11 Wearing a mask is _____ in preventing the spread of diseases.
- (1) urgent
 - (2) critical
 - (3) serious
 - (4) immediate
- 12 The handicapped swimmer _____ her third gold medal at the Paralympics.
- (1) clasped
 - (2) clinched
 - (3) acquired
 - (4) accomplished
- 13 There was a lot of noise coming from the library so Lisa went in to see what the _____ was about.
- (1) commotion
 - (2) conference
 - (3) consideration
 - (4) commemoration
- 14 We had a class _____ based on the motion 'Students should be allowed to bring their pets to school' last week. I was in the opposition team.
- (1) debate
 - (2) dispute
 - (3) argument
 - (4) controversy
- 15 Phone scam cases have been _____ decreasing over the past months as members of the public can now better detect them.
- (1) steadily
 - (2) regularly
 - (3) routinely
 - (4) frequently

For each question from 16 to 20, choose the word(s) closest in meaning to the underlined word(s). Shade the correct oval (1, 2, 3 or 4) on the Optical Answer Sheet. (5 marks)

It was two o'clock in the morning. As Lily could not go back to sleep, she got out of bed and walked leisurely to the kitchen. Whenever she had a hard time sleeping, eating dumplings would (16) always help. She decided to make some. After kneading the dough, she meticulously rolled it (17) into thin sheets. Lily created a filling by mixing ground chicken, garlic and soy sauce. She then (18) scooped some up and placed it at the centre of the dough sheet. She stir-fried the dumplings to a crisp. Savouring them, a smile crept across Lily's face. Eating dumplings reminded her of her (19) roots. She fondly recollected the good times in her old home in China where she used to live (20) with her family. Lily missed them dearly. Eating dumplings always helped her feel close to them.

Adapted from: 200wordshortstory.org

- 16 (1) paced
(2) paraded
(3) marched
(4) sauntered
- 17 (1) strictly
(2) carefully
(3) cautiously
(4) accurately
- 18 (1) diced
(2) sliced
(3) minced
(4) crushed
- 19 (1) Tasting
(2) Enjoying
(3) Devouring
(4) Consuming
- 20 (1) recalled
(2) reviewed
(3) re-examined
(4) reconsidered

Section D: Visual Text Comprehension (8 x 1 mark)

Study this newsletter of an enrichment centre, Happy Learning, and then answer questions 21 to 28.

Happy Learning Enrichment Centre

Issue 25 | June 2022

An Update on the Happy Learning Programme

What the Students Have Covered This Term

Subject	Topic
Reading	Science Fiction
Writing	Writing a Good Description
Maths	Magic Maths Figures
Science	What plants need to grow
Social Studies	Our Founding Fathers
Health Education	A Balanced Diet



Students' Testimonials on the Activities



I loved reading the Science fiction books that my teacher introduced. What is most enthralling is that they help me to imagine what life would be like in outer space! Reading is now more enjoyable as I have found a genre of books that I really like!

Abdul Hakim, Primary 5 student

The writing class allowed me to express my creativity through writing descriptively. I also liked the Maths class where I learnt to solve challenging Maths problems in a fun way. However, the Social Studies class had the biggest impact on me. I learnt about the late Mr Lee Kuan Yew and Dr Toh Chin Chye. They inspire me to be a good citizen.

Jennifer Kwan, Primary 6 student



I found the Health Education lesson very informative! My teacher taught me the importance of having well-balanced meals. Now, I make the effort to fill half my plate with fruits and vegetables so that I can grow healthily!

Vithya Naidu, Primary 2 student

What the Students Can Look Forward to in the Month of July

Tuesday, 5th July
Gardening Day

We will plant flowers in the Learning Hub's new garden from 4 p.m. to 6 p.m. Students should bring old clothes, a hat, and sunscreen.



Friday, 15th July
Learning Journey to the Colonial Village

We will visit the Colonial Village, an air-conditioned premise. Students should bring a jacket, their water bottles, and snacks. The bus will leave at 2 p.m. and return by 5.30 p.m.

Monday, 18th July
Learning Journey to Aspire Institute

We will visit Aspire Institute from 3 p.m. to 4 p.m. The principal and some teachers will give talks and take us around the school. As we will be walking to and from Aspire Institute, students should bring their umbrellas or raincoats in case of wet weather.



Friday, 29th July
Annual Fair

There will be food, music, games and prizes! Students may attend the fair anytime between noon and 6 p.m. at the Learning Hub's atrium.

Magic Maths Figure to Try at Home!

Magic Daisy

Here is a challenge for you. Figure out the numbers that make up a Magic Daisy. At the center of the daisy, write the number 6. Then, write one number from 1 through 11 in each circle. The numbers in each line should add up to 18. Send in your completed Magic Daisy to magicmaths@happylearning.com and stand a chance to win attractive prizes!

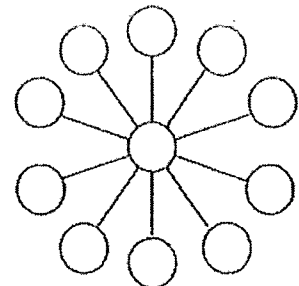

Magic Daisy

For each question from 21 to 28, shade your answer (1, 2, 3 or 4) on the Optical Answer Sheet. (8 marks)

21 What have the students been doing in Science class?

- (1) reading Science fiction books
- (2) understanding the way plants grow
- (3) writing descriptions about Science experiments
- (4) learning about the requirements for plant growth

22 From Jennifer's testimonial, she enjoyed the lesson on _____ most out of all the activities she participated in.

- (1) A Balanced Diet
- (2) Magic Maths Figures
- (3) Our Founding Fathers
- (4) Writing a Good Description

23 What did Hakim find most captivating about the Science fiction books that he read?

- (1) He enjoyed learning about plants.
- (2) His teacher had introduced them to him.
- (3) The books helped him imagine life in outer space.
- (4) The books belonged to a genre of books he enjoyed reading.

24 Students should remember to bring some food on _____.

- (1) 5 July
- (2) 15 July
- (3) 18 July
- (4) 29 July

- 25 Which of the following is not true of the activities in July?
- (1) The students will get to play games.
 - (2) The activities will include a school visit.
 - (3) The students will be outdoors for all the activities.
 - (4) The activities will take place on weekday afternoons.
- 26 What is the purpose of including testimonials in the newsletter?
- (1) to praise the teachers at the centre
 - (2) to provide information about the July programme
 - (3) to build confidence in the readers about the programme
 - (4) to introduce students who participated in the programme
- 27 Bernard tried the completing the Magic Daisy and was successful. He did all the following **except** _____.
- (1) put the number 6 in the middle circle.
 - (2) filled all the circles with the numbers 1 to 11
 - (3) made sure each circle contained only one number
 - (4) checked that the sum of the numbers in each line was 18
- 28 What is the main purpose of the article?
- (1) to feature students' testimonials of the programme
 - (2) to promote the programmes available at the centre
 - (3) to remind students about the items they need to bring
 - (4) to help students remember the things they have learnt

Please note that the passage for Comprehension questions 71 to 80 in Booklet B is on the next page. You may now go on to Booklet B.

Refer to the passage below when you answer questions 71 to 80 in Booklet B.

Michael loved playing basketball. Every Saturday, he played with his older brothers, Larry and Ronnie, but he was always defeated by the tallest boy on the court, Mark. Despite the defeats, Michael continued to play every week to overcome the challenge.

A few days after the last defeat, Michael was sitting in the kitchen, looking disappointed. Mama saw the look on his face and said, "You guys lost again today, huh?"

Michael nodded. He sat quietly for a minute, then asked, "Mama, how can I grow taller?" Now, Mama knew the answers to a lot of questions, but this was a tough one. She stumbled for a moment as she sprinkled salt on the chicken she was making for dinner. Then, she smiled, looked at Michael, and said, "Salt. Salt in your shoes. If you practise with salt in your shoes every day, you'll be taller before you know it!" she replied. 11

"Salt in my shoes?" Michael said quietly to himself, scrunching his eyebrows. At the same time, he noticed the rose bushes outside in Mama's garden. They had grown high along the fence, and roses of all colours were blooming on the vines. Michael's face lit up. If Mama knew how to make those rose bushes grow tall, then maybe she was right. That night, when Mama came into his room, Michael was asleep with a smile etched on his face. By his bed, Mama sprinkled salt into his shoes. Then, she prayed quietly over him as she did for all her children. 15

After that night, Michael wore his favourite game shoes with salt everywhere he went. He stopped going to the park with his brothers on Saturdays. Instead, he stayed home and practised every day like Mama had advised. He wanted to grow a few more inches before going back to the park to defeat Mark. He started recording his height daily. After two months of practising, Michael stood next to the growth chart on his wall again but alas, he had not grown an inch. Two more months of practising went by and still nothing. Not only had he not grown taller, he also missed playing basketball with Larry and Ronnie. 20

Mama came home that Saturday and found Michael looking gloomy. "What's wrong, son? Are you okay?" 25

He said, "It didn't work. I can't be a great player if I do not grow taller."

"But you are a great player, son. You already have everything it takes to be a winner, right in here," Mama tapped Michael on his chest. "Being taller may help you play better, but not as much as practice, determination, and doing one's best. Those are what make you a real winner."

Mama's words gave Michael a new found sense of motivation. He rushed to the game. With salt in his shoes, Michael showed off the fruit of his labour. He finally defeated Mark for the first time. After that day, Mama stopped putting salt in Michael's shoes, but what she taught him impacted him for the rest of his life. Michael never stopped doing what Mama had advised and that helped him become widely-acknowledged as the greatest basketball player of all time – Michael Jordan. 35

Adapted from 'Salt in His Shoes' by Doloris Jordan



RED SWASTIKA SCHOOL
2022 MID-YEAR EXAMINATION
ENGLISH LANGUAGE – PAPER 2
LANGUAGE USE AND COMPREHENSION
PRIMARY 6

Name : _____ ()

Class : Primary 6 / _____

Date : 10 May 2022

BOOKLET B

52 Questions
67 Marks

In this booklet, you should have the following:

- a. Page 10 to Page 16
- b. Questions 29 to 80

BOOKLET	OBTAINED	POSSIBLE
BOOKLET A		28
BOOKLET B		67
TOTAL		95

Parent's Signature : _____



There are 10 blanks, numbered 29 to 38, in the passage below. From the list of words given, choose the most suitable word for each blank. Write its letter (A to Q) in the blank. The letters (I) and (O) have been omitted to avoid confusion during marking. (10 marks)

EACH WORD CAN BE USED ONLY ONCE.

- | | | | | |
|---------|------------|-----------|-----------|-----------|
| (A) all | (D) be | (G) every | (K) in | (N) to |
| (B) as | (E) by | (H) for | (L) of | (P) with |
| (C) at | (F) during | (J) from | (M) these | (Q) which |

The *Museum of Ice Cream* set up a shop in Dempsey last August. It is one of the initiatives by Singapore Tourism Board (STB) _____ seeks to enhance Singapore's attractiveness to prepare its hard-hit tourism sector _____ recovery.

(29)

(30)

Mr Tan, chief executive of STB, said, "The opening of _____ innovative attractions adds vibrancy to our city, and builds the tourism industry's confidence _____ Singapore's continuing appeal as a top travel destination."

(31)

(32)

Visitors to the *Museum of Ice Cream* will _____ guided through 14 multi-sensory sections with interactive displays. _____ activities are dedicated to ice cream, which visitors will also get to try _____ their visit.

(33)

(34)

(35)

Another highlight is a sprinkle pool advertised as the museum's largest pool _____ date. The sprinkles, which come in a variety of colours and used _____ a topping for ice cream, is disinfected regularly.

(36)

(37)

A maximum capacity of 200 guests is allowed at any one time. Knowing that this could be a concern, STB's Mr Tan reassured the public that their safety is a priority. "The museum will abide _____ hygiene and safe distancing guidelines. We will keep visitors safe," he said.

(38)

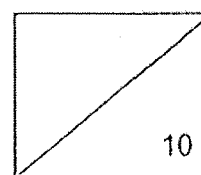

Adapted from The Straits Times – Museum of Ice Cream to open in Dempsey in August

Each of the underlined words contains either a spelling or grammatical error. Write the correct word in each of the boxes. (12 marks)

When I was young, ice ball was my favourite dessert. I could not resist
(39) (40)
the temptaysion to get one as a relieve from the sweltering mid-day heat. I

was lucky enough to have an ice-ball stall near my school which I visited
(41)
ocasionally.

(42) (43)

Though not considered a newtritious snack, the ice ball was an immense

(44)

popular treat for children in the past. Each ice ball cost between five to ten

(45)

cents. It is made use shaved ice, moulded by hand into the shape of a ball

(46)

(47)

and then drizzle with evaporated milk and various syrups in diferrent colours.

(48)

Some sellers would add ingreediants like jellies or cooked red beans in the

(49)

center of the ball as an addytionel treat. Upon request, the seller could also

cut the ball in half so it could be shared with a friend.

(50)

The dessert eventually evolved from 'ice kachang', the colourful dessert we know today. It is now a favourite among many Singaporeans.

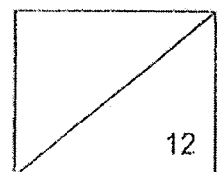

Fill in each blank with a suitable word.

(15 marks)

When a bird loses its feathers and can no longer fly, vets in Singapore can use a special 'feather extension' technique to restore its wings and return it to the sky. This technique, invented centuries _____, refers to the joining of the remains of a damaged feather to a new feather.

The new feather is affixed by inserting a needle, which is _____ of bamboo, and securing it by _____ a strong glue. Feathers used in this procedure have to be from the _____ species as the bird being treated, and not just any bird.

Recently, this procedure was _____ out on an eagle at the hospital in Jurong Bird Park. The eagle was found with severe _____ to all the important flight feathers on its wings and tail, causing it to lose its _____ fly.

Upon closer _____ by the vets at the hospital, the bird was found to be in good health, _____ from its feathers that were burnt.

A spokesman for the park said, "To replace lost or damaged feathers, birds will naturally grow new feathers through the moulting cycle. It could, however, _____ up to twelve months for the eagle to fully regrow its feathers and be able to fly _____."

The long duration is an issue because keeping a wild bird in captivity comes with risks, _____ as causing unnecessary stress to the bird, or the bird becoming too dependent on humans, thus unable to _____ for itself.

Therefore, to _____ up the process of releasing the bird into the wild, the veterinary team decided to fix both its wings and tail feathers. The eagle had more _____ fifty of its feathers on its wings and tail fixed successfully.

After adapting to its new feathers well, the eagle took off a day later.

<https://www.straitstimes.com/singapore/environment/feather-extensions-helps-native-raptor-fly-again>

15

For each of the questions 66 to 70, rewrite the given sentence(s) using the word(s) provided. Your answer must be in **one** sentence. The meaning of your sentence must be the same as the meaning of the given sentence(s). (10 marks)

66 Mother told me to make the room beautiful.

_____ the room.

67 The boy is crying to his mother. His toy is broken.

_____ whose

68 The boys have to deliver the box of books to the library.

The box of books _____

69 Anticipating that his father was reaching home, Ben stood at the front door.

Ben stood at the front door at the _____

70 "How did you find this book?" Beth asked Ali.

Beth wanted to know _____

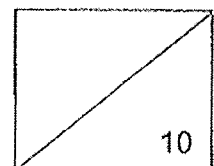

Read the passage on page 9 of Booklet A and answer questions 71 to 80.

71 Why did Michael want to grow taller? (1m)

72 From paragraph 1, how would you describe Micheal's attitude towards challenges? Support your answer with evidence from the passage. (2m)

Description:	
Evidence:	

73 What made Mama suggest putting salt into Michael's shoes? (1m)

74 Why did Michael believe Mama's suggestion that salt in his shoes would help him grow taller? (2m)

75

Write 1, 2 and 3 in the blanks below to indicate the order in which the events occurred in the story. (1m)

- _____ Michael became a well-known basketball player.
- _____ Michael defeated Mark for the first time.
- _____ Michael was convinced that Mama's advice would work .

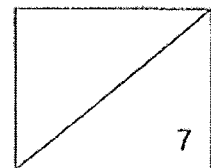

- 76 Which two words correctly describe how Michael felt in lines 17 - 25? Put a tick in the box beside each of your answers. (2m)
DO NOT TICK MORE THAN TWO BOXES.

angry	<input type="checkbox"/>	neglected	<input type="checkbox"/>
enthusiastic	<input type="checkbox"/>	abandoned	<input type="checkbox"/>
satisfied	<input type="checkbox"/>	disappointed	<input type="checkbox"/>

- 77 Fill in the following table by identifying the correct word(s) from the passage. (3m)

Question	Word from the passage
a) Which word from the first paragraph tells us that Micheal and his brothers found defeating Mark a difficulty?	
b) Which word from the third paragraph tells us that Mama was unsure about answering Micheal's question?	
c) Which two-word phrase from the fourth paragraph tells us that Micheal was excited about Mama's method in helping him to grow taller?	

- 78 Look at the table below. What do the words in the left column refer to in the passage? Write your answers in the column on the right. (3m)

Word(s) from the passage	What the word(s) refer(s) to
one (line 7)	
It (line 26)	
labour (line 31)	

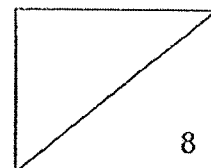

79 Based on the story, state whether each statement in the table below is true or false, then give one reason why you think so. (3m)

Statement	True/False	Reason
Michael stopped playing basketball with his brothers because he was afraid of Mark.		
Micheal believed without hesitation Mama's claim that salt would help him grow tall.		
Micheal was anxious to check if he was growing taller.		

80 Explain clearly what helped Michael become a successful basketball player. (2m)

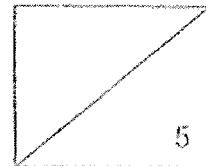

END OF PAPER

SCHOOL : RED SWASKITA PRIMARY SCHOOL
 LEVEL : PRIMARY 6
 SUBJECT : ENGLISH
 TERM : SA1 2022

Booklet A

Q 1	Q2	Q3	Q4	Q5	Q6	Q7	Q8	Q9	Q10
2	1	3	2	1	3	3	4	4	3
Q11	Q12	Q13	Q14	Q15	Q16	Q17	Q18	Q19	Q20
2	2	1	1	1	4	2	3	2	1
Q21	Q22	Q23	Q24	Q25	Q26	Q27	Q28	Q29	Q30
4	3	3	2	3	3	2	2	Q	H
Q31	Q32	Q33	Q34	Q35	Q36	Q37	Q38		
M	K	D	A	F	N	B	E		

Q39)	temptation	Q44)	and	Q49)	additional
Q40)	relief	Q45)	using	Q50)	into
Q41)	occasionally	Q46)	drizzled	Q51)	ago
Q42)	nutritious	Q47)	different	Q52)	made
Q43)	immensely	Q48)	ingredients	Q53)	using
Q54)	same	Q58)	examination	Q62)	such
Q55)	carried	Q59)	apart	Q63)	fend
Q56)	damage	Q60)	take	Q64)	speed
Q57)	ability	Q61)	again	Q65)	than

Q66)	Mother told me to beautify the room.
------	--------------------------------------

Q67)	The boy ,whose toy is broken, is crying to his mother.
Q68)	The box of books has to be delivered to the library by the boys.
Q69)	Ben stood at the front door at the anticipation of his father reaching home.
Q70)	Beth wanted to know how Ali had found that book.
Q71)	1) Michael wanted to defeat the tallest boy on the court by growing taller. 2) Michael wanted to win over basketball.
Q72)	Description : determined Evidence : Despite defeats, Michael continued to play every week to defeat Mark.
Q73)	She was sprinkling salt on the chicken she was making for dinner.
Q74)	Michael thought/ believed that if Mama knew how to make rose bushes grow then she could be right about putting salt in his shoes to help him to grow taller.
Q75)	3, 2, 1
Q76)	enthusiastic / disappointed
Q77)	a)challenge b)stumbled c)lit up
Q78)	(line 7) --- the question on how to grow taller. (line 26) --- putting salt in Michael's shoes to help him grow taller. (line 31) --- four months of practice.
Q79)	False --- He wanted to grow a few more inches before going back to the park to defeat Mark. False --- He scrunched his eyebrows when he heard Mama's claim. True – Michael recorded his height daily.
Q80)	Michael never stopper practising kept on practising, being determined, and doing his best. Michael heeded Mama's advice, and kept on practising, being determined, and doing his best.