



SINGAPORE CHINESE GIRLS' SCHOOL
SECOND SEMESTRAL ASSESSMENT 2022

PRIMARY 5

SCIENCE

BOOKLET A

Total Time for Booklets A and B: 1 h 45 min

Name : _____ ()

26 October 2022

Class : Primary 5 SY / C / G / SE / P

INSTRUCTIONS TO CANDIDATES

1. Do not open this booklet until you are told to do so.
2. Follow all instructions carefully.
3. Answer all questions.
4. Shade your answers in the Optical Answer Sheet (OAS) provided.

This booklet consists of 14 printed pages.

Booklet A (56 marks)

For each question from 1 to 28, four options are given. One of them is the correct answer. Make your choice (1, 2, 3 or 4). **Shade the correct oval (1, 2, 3 or 4) on the Optical Answer Sheet.**

1. Study the chart below.

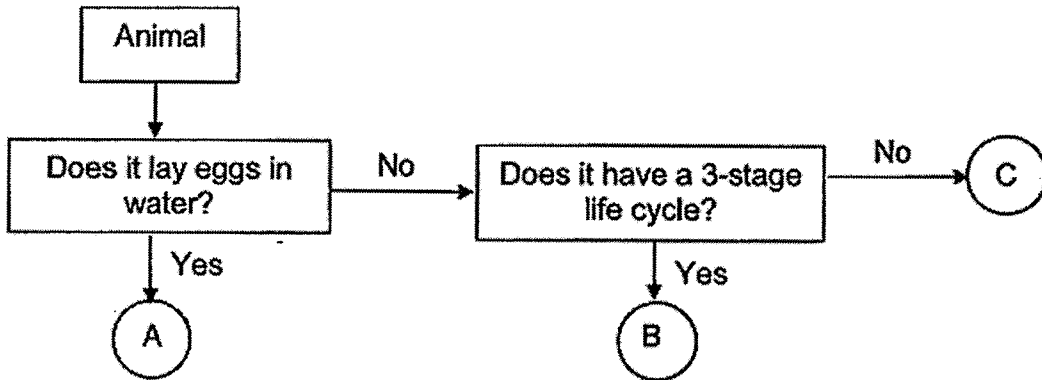

Based on the information above, which of the following correctly represents animals A, B and C?

	A	B	C
1)	frog	grasshopper	butterfly
2)	frog	butterfly	grasshopper
3)	mealworm	butterfly	grasshopper
4)	mealworm	grasshopper	butterfly

2. Study the diagram below.

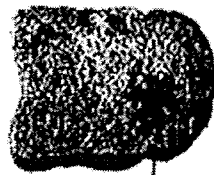

bread mould

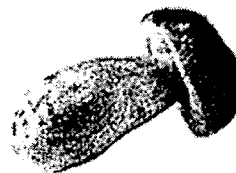

mushroom

The following statements were made by Sam, Ted and Uma.

Sam : Both of them reproduce by spores.

Ted : Mushroom can make its own food, but the bread mould cannot.

Uma : All mushrooms and bread mould are poisonous.

Who is/are correct ?

1) Sam only

2) Ted only

3) Sam and Uma only

4) Ted and Uma only

3. A bell jar made of clear glass is placed over a healthy plant. The set-up is placed under bright light in a room for several hours. The rate of photosynthesis is higher than the rate of respiration.

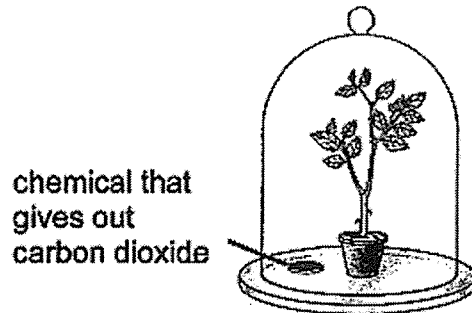

Which of the following graphs correctly shows the amount of oxygen in the set-up over an hour?

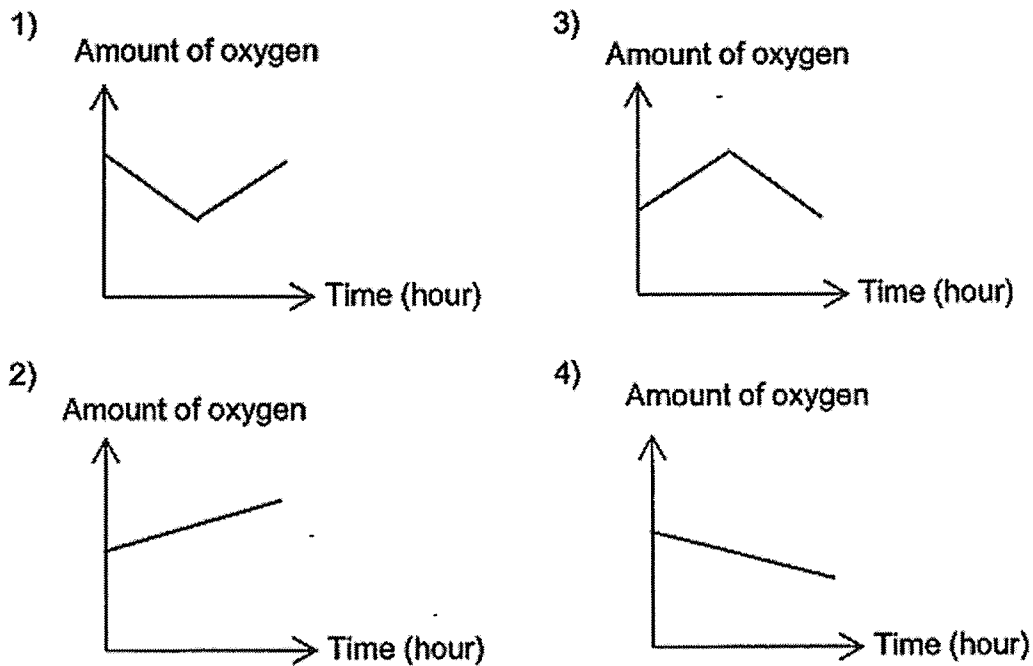

4. Caryn wants to find out the conditions necessary for mealworms to survive. An equal number of mealworms were put into the four tanks A, B, C and D. A tick (✓) shows that the condition is present.

Tanks	Temperature of surroundings	Conditions		
		Light	Water	Air
A	40°C		✓	✓
B	30°C	✓	✓	✓
C	40°C		✓	✓
D	30°C	✓		✓

Based on the table above, Caryn aims to find out if _____ is needed for mealworms to survive.

- 1) light
2) air
3) water
4) warmth

5. The diagram below shows a human digestive system.

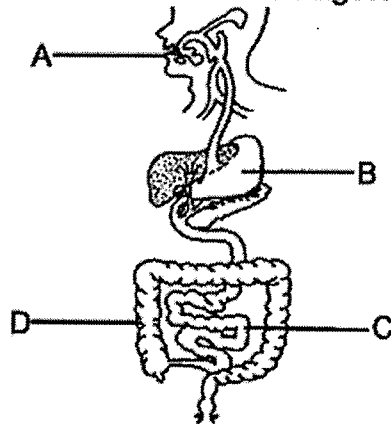

Which bar graph below shows the correct amount of digested food leaving the parts A, B, C and D?

1)

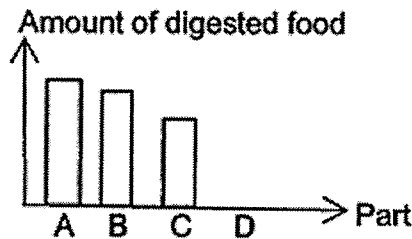

3)

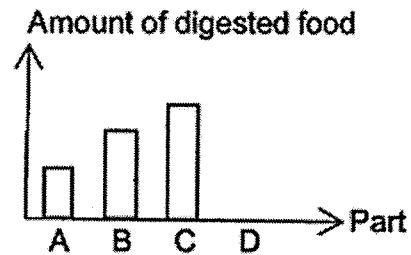

2)

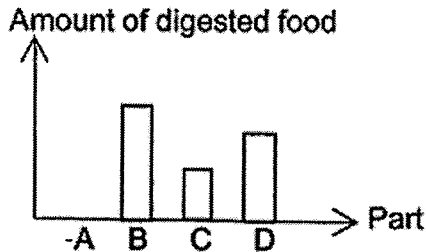

4)

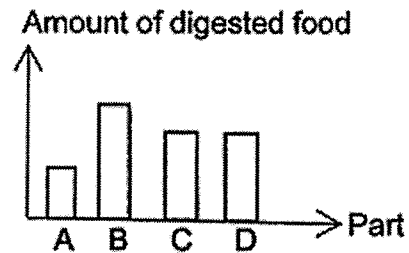

6. Some adults and children were trapped in a faulty lift where air could not enter or escape. The graph below shows the composition of air in the lift. Which of the following best represents the composition of air after an hour?

At the start



After an hour

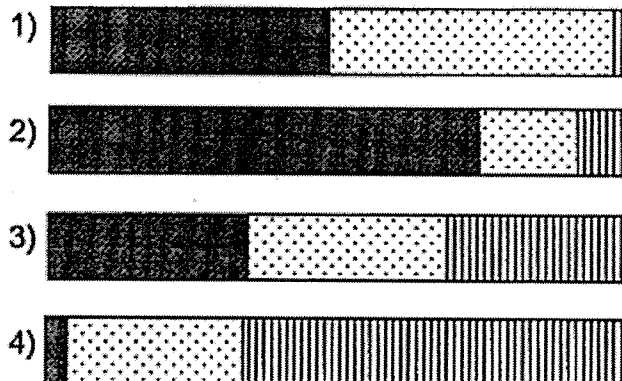

Legend

■ Nitrogen

▨ Oxygen

▨ Other gases

7. P, Q, R and S are all beetle M at different stages of Beetle M's life cycle. They were each separately kept in containers with 20 g of food inside. After two days, the mass of the food was weighed and recorded in the table below.

Beetle M	Mass of food left after two days
P	10 g
Q	5 g
R	8 g
S	20 g

Which of the following, P, Q, R or S, is most likely to be beetle M in the pupa stage?

- 1) P
2) Q
3) R
4) S
8. The diagram below shows part X of a plant.

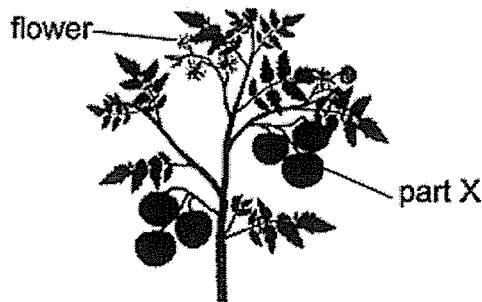

Which processes must have taken place for the development of part X from a flower?

- 1) pollination and fertilisation
2) germination and pollination
3) fertilisation and germination
4) seed dispersal and germination
9. Which of the following statements about human reproduction are true?

A : Sperm cells are produced in large numbers by the ovary.
B : One egg is fertilised by many sperms.
C : The fertilised egg will develop in the stomach.
D : Two sex cells are needed to produce an offspring.

- 1) B only
2) D only
3) B, C and D only
4) A, B and D only

10. The diagram shows how three human body systems work together.

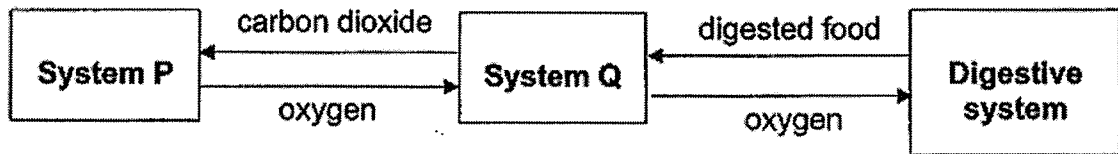

Which of the following statements is/are true about System P and System Q?

- A) System P carries out gaseous exchange.
- B) The windpipe in System P allows the air to travel from nose to lungs.
- C) System Q contains heart, blood vessels and lungs.
- D) System Q carries only oxygen and digested food to all parts of the body.

- 1) A only
- 2) B only
- 3) A and B only
- 4) All of the above

11. Which of the following shows the correct order in which carbon dioxide is removed from the leg in the human body?

- 1) Bloodstream → Heart → Lungs → Windpipe → Nose
- 2) Bloodstream → Lungs → Heart → Windpipe → Nose
- 3) Nose → Windpipe → Lungs → Heart → Bloodstream
- 4) Nose → Lungs → Windpipe → Bloodstream → Heart

12. The table shows a comparison of an animal cell and a leaf cell.

	Muscle cell	Leaf cell
A)	It has cell wall that gives it a shape	It does not have a cell wall
B)	It contains genetic information in the nucleus	It contains genetic information in the nucleus
C)	It has cytoplasm	It does not have cytoplasm
D)	It does not have chloroplasts	It has chloroplasts

Which of the above comparisons is/are true?

- 1) A only
- 2) B and C only
- 3) B and D only
- 4) D only

13. Animal F lives in cold countries. It has a thick layer of black fur on its body which humans make into winter coats. Which of the following explains why humans use animal F's fur to make into winter coats?

- 1) The fur helps the person to gain more heat from the surroundings.
- 2) The fur helps the person lose less heat to the surroundings.
- 3) The fur absorbs heat faster from the human body.
- 4) The fur loses more heat to the human body.

14. Sally placed three objects X, Y and Z into a tank of water.

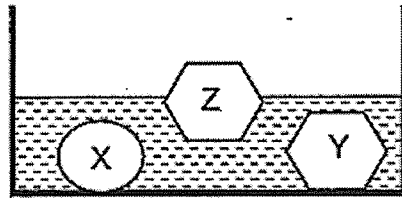

She made the following statements.

A : X and Y have the same mass.

B : X and Y are made of the same material.

C : Y and Z are made of different materials.

Which of the following statement(s) is/are definitely true?

- 1) A only
- 2) C only
- 3) A and B only
- 4) B and C only

15. Four metal cubes, P, Q, R and S, of the same temperature, were lowered into a basin of hot water. The metal cubes are made of the same material but different volume.

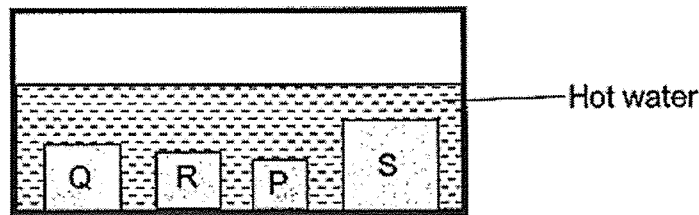

Which cube will take the longest time to reach the same temperature as the hot water?

- 1) P
- 2) Q
- 3) R
- 4) S

16. A glass container with capacity 500 cm³ is filled with 200 cm³ of water. It is connected to two syringes as shown below.

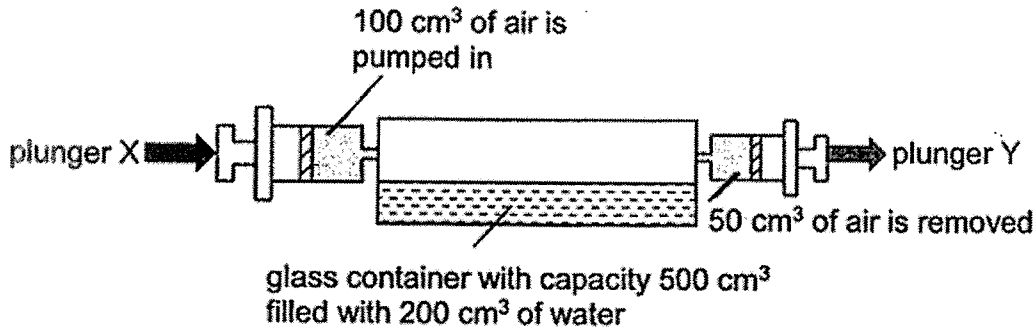

When the plunger X is pushed in completely, 100 cm³ of air is pumped into the glass container. When plunger Y is pulled out completely, 50 cm³ of air is removed.

What is the final volume of air in the glass container?

- 1) 200 cm³
2) 250 cm³
3) 300 cm³
4) 350 cm³
17. Which of the following statements about water cycle is/are correct?
- A : Water loses heat when it evaporates.
B : Clouds are made up of water droplets.
C : Water can change state when it gains heat.
- 1) A only
2) B only
3) A and B only
4) B and C only
18. The boiling point and melting point of two substances, P and Q, are shown in the table below.

	Substances	
	P	Q
Boiling point	400°C	70°C
Melting point	2°C	10°C

At which temperatures are both substances P and Q liquids?

- 1) 1°C
2) 15°C
3) 80°C
4) 410°C

19. Three identical towels A, B and C with the same amount of water were left to dry under the sun. Each towel was folded to expose a different amount of surface area as shown below. The three towels were weighed at regular intervals until all of them were completely dry. The results were recorded in a graph.

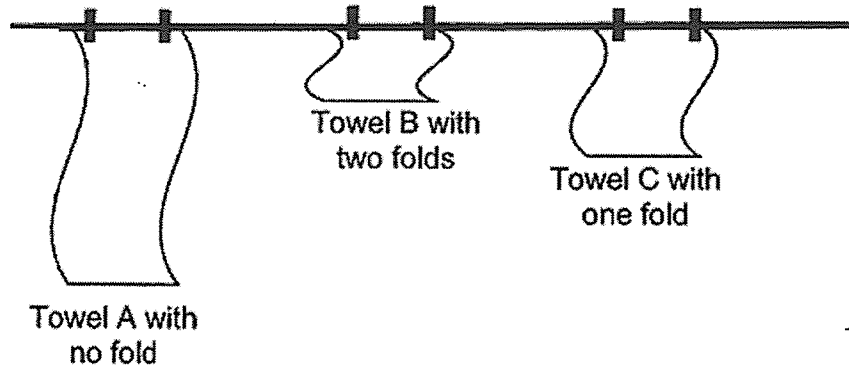

Which graph represents the results correctly?

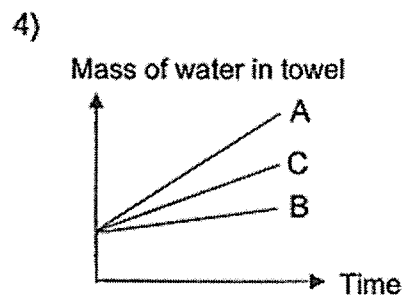
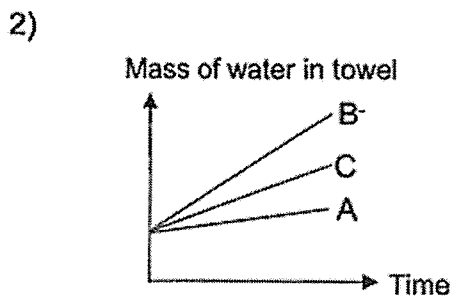
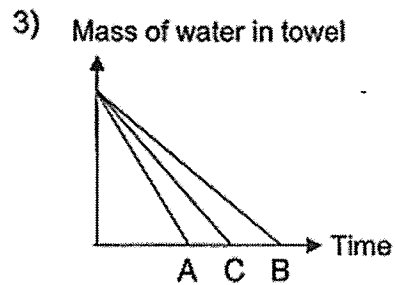
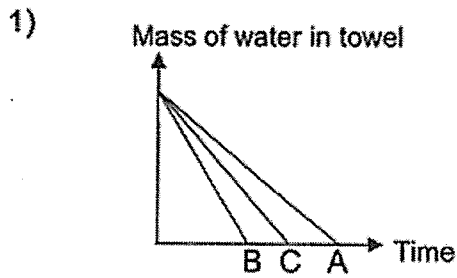

20. Rina wanted to find out whether four materials A, B, C and D were electrical conductors or insulators using the electrical circuit shown below.

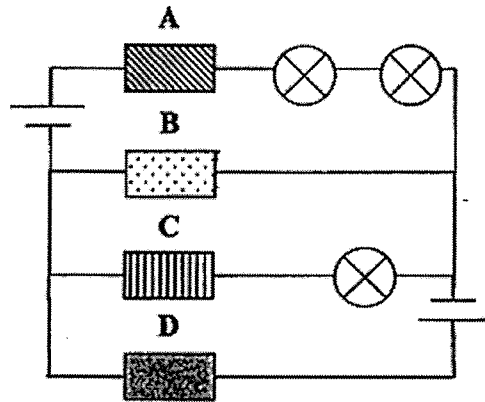

It is observed that all the three bulbs lit up.
Which of the following about A, B, C and D is correct?

	A	B	C	D
1)	conductor	insulator	insulator	insulator
2)	insulator	conductor	conductor	insulator
3)	conductor	insulator	conductor	conductor
4)	insulator	conductor	insulator	conductor

21. Five bulbs are connected in an electrical circuit as shown below.

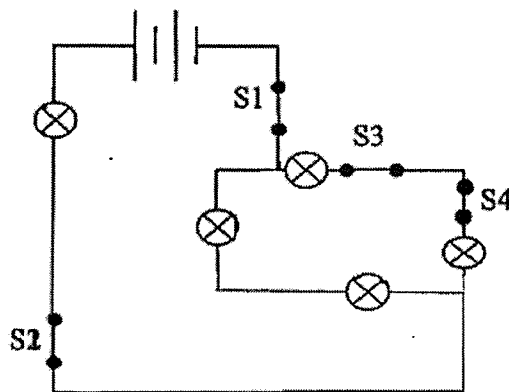

Which of the following is the correct observation when selected switches are closed?

	Switches that are closed	Number of bulbs light up
1)	S1 only	1
2)	S1 and S2 only	3
3)	S1, S3 and S4 only	3
4)	S2, S3 and S4 only	5

22. A circuit card with clips A, B, C, D, E and F are connected to X and Y of a circuit tester as shown below.

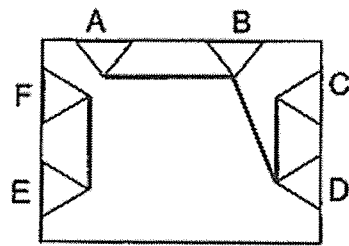

Circuit Card

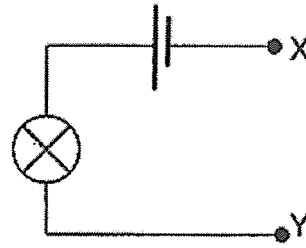

Circuit Tester

Which of the following shows the correct observations when the following combination of clips are connected to the circuit tester?

	A and C	B and F	D and E
1)	Lights up	Does not light up	Lights up
2)	Does not light up	Lights up	Lights up
3)	Lights up	Does not light up	Does not light up
4)	Does not light up	Lights up	Does not light up

23. The object below is placed between a torch and a screen in different positions.



Which of the following cannot be a shadow of this object?

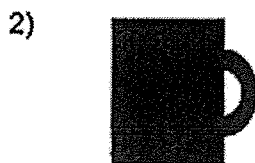
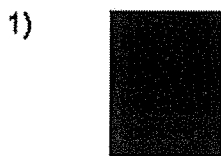

24. An experiment was conducted in a dark room. Light was shone through P, Q, R and S which were made of different materials that had the same thickness.

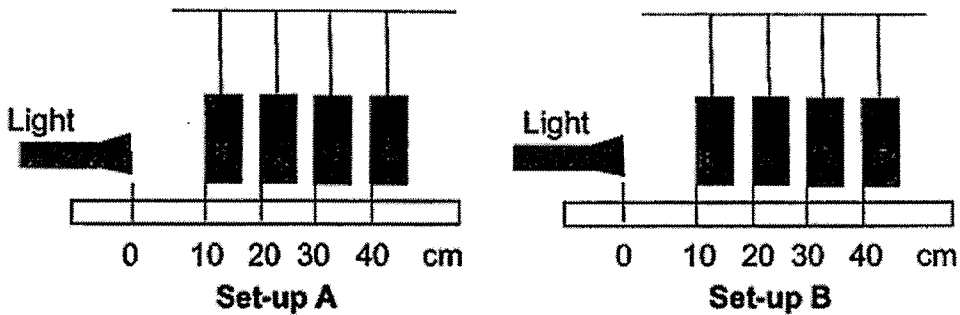

The distance travelled by the light before it was fully blocked was measured and recorded below.

Set-up	Distance travelled by light before it was blocked
A	40 cm
B	20 cm

Which one of the following correctly describes the property of sheets P, Q, R and S?

	Does it allow light to pass through?			
	P	Q	R	S
1)	Yes	Yes	Yes	Not possible to tell
2)	No	Yes	No	Not possible to tell
3)	Yes	Yes	Yes	No
4)	Yes	No	Yes	No

25. The arrows indicate how light travels so that Joan could see her friend in the classroom.

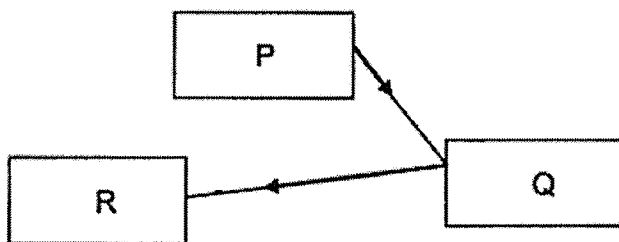

Based on the diagram above, what do P, Q and R represent?

	P	Q	R
1)	friend	Joan	light source
2)	Joan	friend	light source
3)	light source	Joan	friend
4)	light source	friend	Joan

26. Shirley set up an experiment with a magnet and four blocks of different materials A, B, C and D. The blocks were of equal mass and length. She hung block A which was made of wood and measured the distance P as shown in the diagram below.

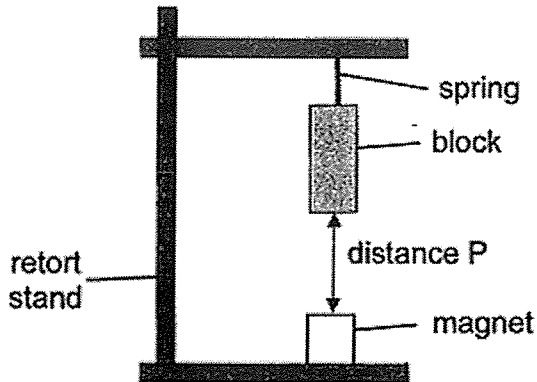

She repeated the experiment with the other three blocks and the results were recorded in table below.

Block	Distance P (cm)
A (wood)	5
B	6
C	3
D	7

- Which block(s) is/are definitely magnets?
- 1) C only
2) D only
3) B and D only
4) C and D only

27. The diagram shows a mixture of beads A and B being separated by a magnetic system with two wheels X and Y. The mixture of A and B was poured onto a roller belt and sorted into different containers.

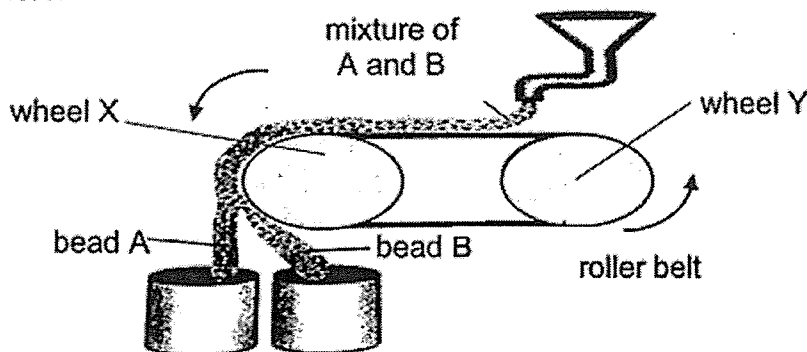

Which of the following correctly shows what X, Y, A and B are likely to be made of?

	wheel X	wheel Y	A	B
1)	magnet	aluminium	plastic	steel
2)	magnet	aluminium	steel	plastic
3)	aluminium	magnet	plastic	steel
4)	aluminium	magnet	steel	plastic

28. Jenny set up an electromagnet and places it between a copper rod and a steel rod as shown below.

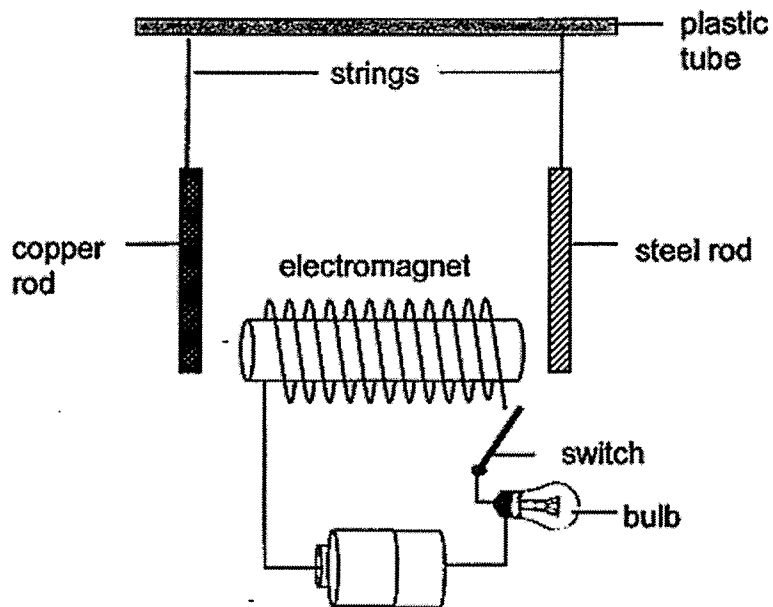

What is she likely to observe when she closes the switch?

	Bulb	Copper rod	Steel rod
(1)	lights up	moves away from electromagnet	remains still
(2)	does not light up	move towards electromagnet	moves towards electromagnet
(3)	does not light up	remains still	moves towards electromagnet
(4)	lights up	remain still	moves towards electromagnet

End of Booklet A



SINGAPORE CHINESE GIRLS' SCHOOL
SECOND SEMESTRAL ASSESSMENT 2022

PRIMARY 5

SCIENCE

BOOKLET B

Total Time for Booklets A and B: 1 h 45 min

Name : _____ ()

26 October 2022

Class : Primary 5 SY / C / G / SE / P

INSTRUCTIONS TO CANDIDATES

1. Do not open this booklet until you are told to do so.
2. Follow all instructions carefully.
3. Answer all questions.

	Max Mark	Marks attained
Booklet A	56	
Booklet B	44	
Total Marks	100	

Parent's Signature

This booklet consists of 12 printed pages.

Booklet B (44 marks)

For questions 29 to 39, write your answers in this booklet.

The number of marks available is shown in brackets [] at the end of each question or part question.

29. (a) The diagram below shows the germination of a seed and its growth into a seedling.

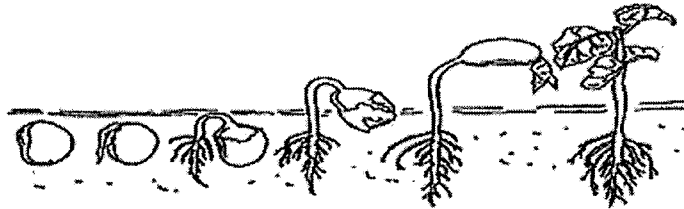

- (i) Explain why the roots of the seedling grow first. [1]

- (ii) Name the part of the seedling that provides food for growth before the true leaves develop to make food. [1]

- (b) (i) Complete the diagram below to show the life cycle of a butterfly. [1]

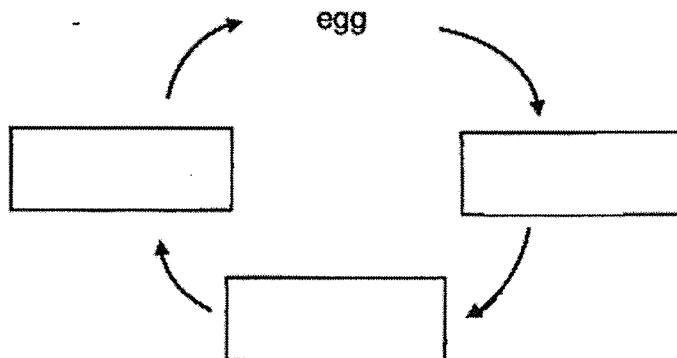

- (ii) Explain how the adult butterfly can be useful to the flowering plants. [1]

30. (a) The diagram below shows four parts of a flowering plant.

Complete the diagram by drawing two arrows to show the direction which water is transported in a plant. The first arrow has been drawn for you. [1]

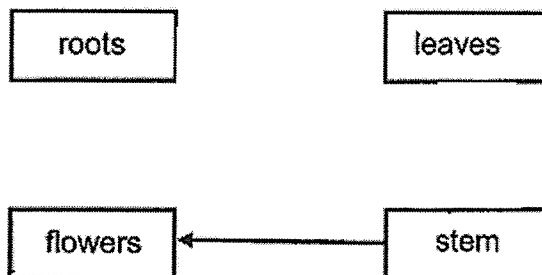

(b) The gardener removed the outer ring of the stem of the tree.

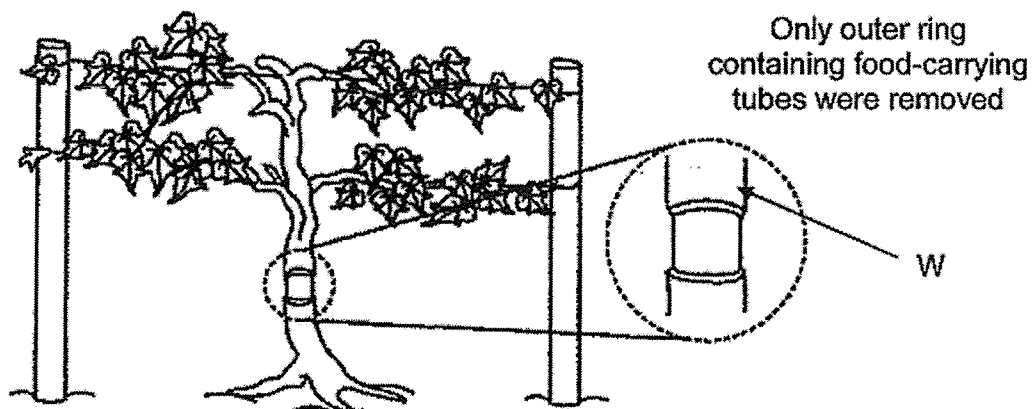

He measured and recorded the width of the stem at W.

(i) What would happen to the width of the stem at W on Day 3?

Circle your answer below.

Increase

Remain the same

Decrease

[1]

(ii) Explain the change in the width of the stem from Day 1 to Day 3.

[1]

(iii) Explain why the roots died after a month.

[1]

(iv) What would happen to the leaves after another month? Explain.

[1]

31. Jolene is exercising at the fitness corner. The graph below shows how Jolene's heart rate changes over time during the 20 minutes of exercise.

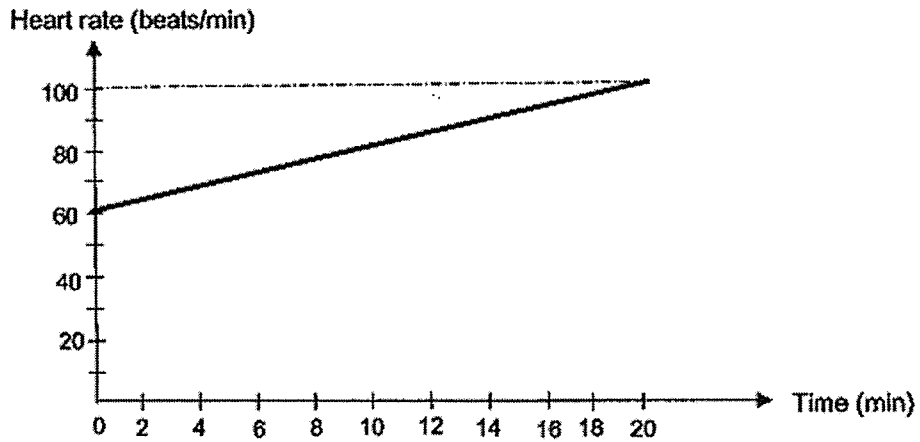

(a) Based on the graph above, what is the relationship between the time taken for Jolene's exercise and her heart rate? [1]

(b) Describe how the oxygen from the surrounding air enters Jolene's body and eventually reach her legs. [2]

(c) Jolene stopped exercising at the 20th minute and her heart rate was 100 beats/min. In the graph below, draw a line graph to show the changes in Jolene's heart rate for the next six minutes after she stopped exercising. [1]

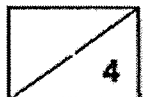
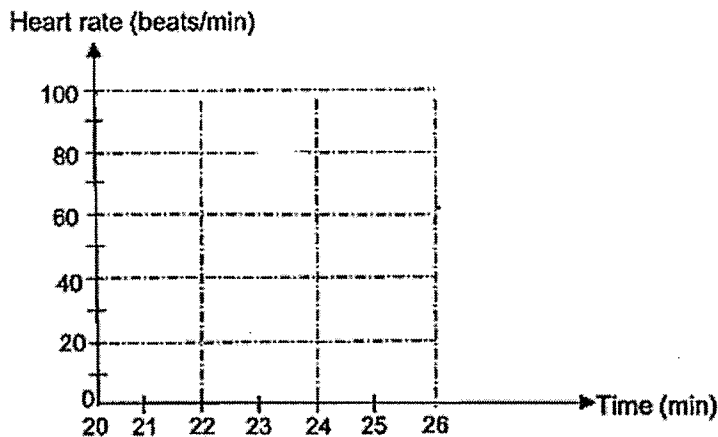

32. Angeline conducted an experiment as shown below. Equal amounts of water and oil were added into each of the containers, A, B and C. The set-ups were placed next to the window.

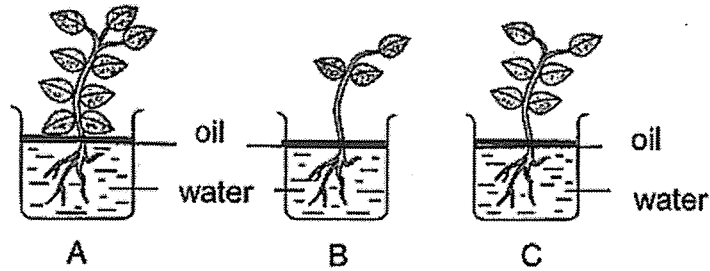

The amount of water left in all the three containers were recorded daily over a period of one week. The results were plotted in the graph as shown below.

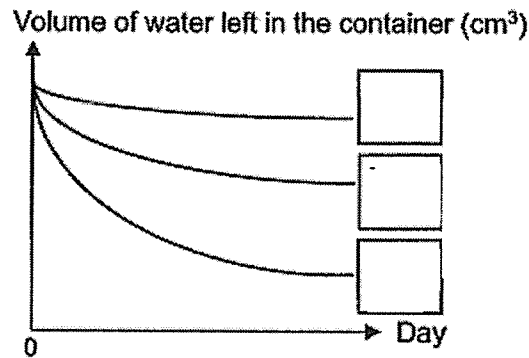

- (a) On the graph above, identify the graph for set-ups A, B and C by labelling the lines A, B and C respectively in the boxes provided. [1]

- (b) Explain your answer for Set-up A in (a). [2]

- (c) Explain how placing all the set-ups at the same place make the experiment a fair test. [1]

33. (a) A field study was conducted on the seed dispersal of different plants. The distribution of seeds by the plants were recorded as shown in the diagram below.

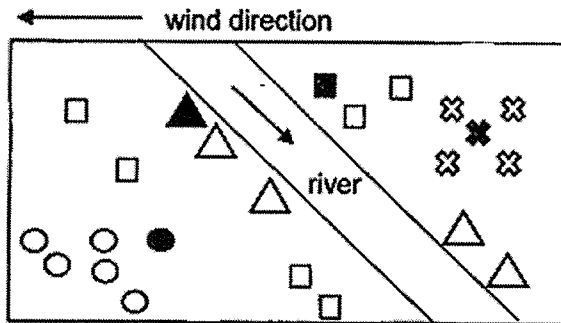

Legend

Parent plant	Seedling
●	○
■	□
▲	△
⊗	⊗

State the possible method of seed dispersal of the following plants. [1]

	Parent plant	Dispersal method
(i)	▲	
(ii)	●	

(iii) Give a reason for your answer in (a) (i) ▲. [1]

(b) The diagrams below show two fruits E and F.

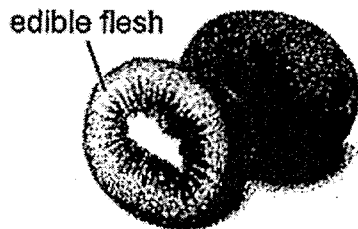

Fruit E

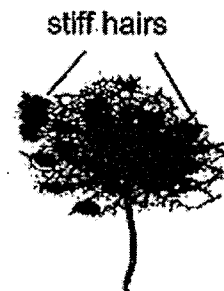

Fruit F

(i) State one similarity of seed dispersal for fruits E and F. [1]

(ii) Describe how fruit F is dispersed. [1]

34. (a) State two substances produced during photosynthesis.

[1]

(b) Xiao Ting took two green leaves, X and Y, from the same plant. She coated one side of each leaf with thick layer of paint immediately as stated in the table below.

Leaf	Coated with paint
X	top
Y	bottom

The leaves were soaked in separate beakers filled with water.

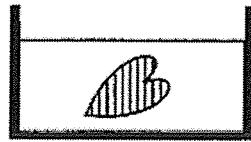

Leaf X in beaker

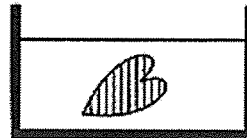

Leaf Y in beaker

The set-ups were then brought under the sun.

(i) Which beaker, with Leaf X or Leaf Y, would Xiao Ting observe more air bubbles after a while? Give a reason for her observation.

[2]

(ii) Which of the following variables should Xiao Ting keep the same to ensure a fair test? Tick (✓) the appropriate boxes.

[1]

Variable	Tick (✓) if correct
Size of leaf	
Amount of air bubbles	
Type of leaf	
Surface area of leaf	
Volume of water	



35. The parts in the human digestive system can be classified as shown.
 (a) Complete the table by giving suitable headings.

[1]

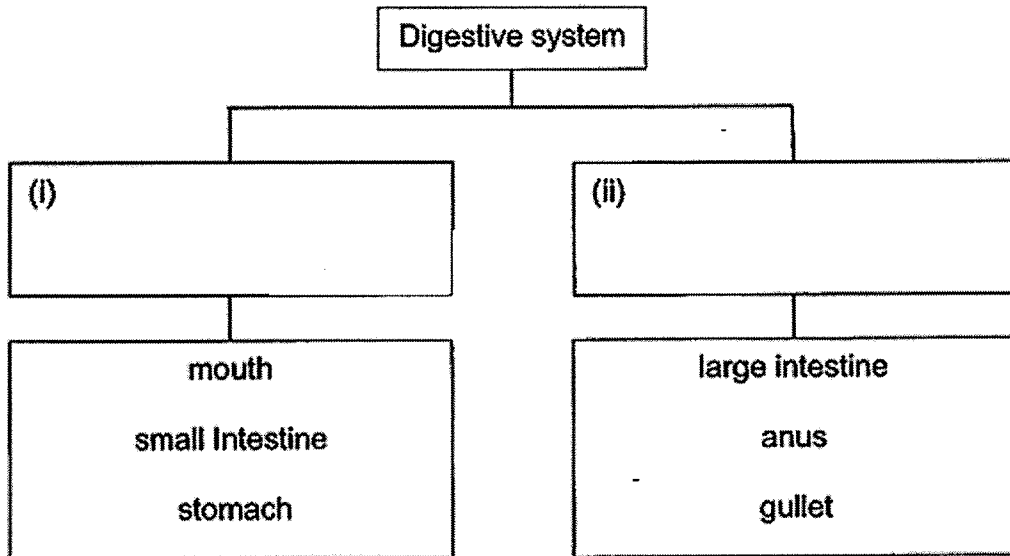

(b) Name the digestive juice found in the mouth.

[1]

(c) Susan has two similar biscuits A and B. They are soaked in digestive juices. Susan finds that biscuit B digested first.

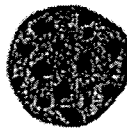

biscuit A



biscuit B

Based on Susan's observation, explain how our teeth helps to speed up the digestion of food.

[2]

36. (a) The diagram below shows a water cycle.

(i) Draw **two arrows** in the diagram to show how plants can be part of this water cycle. [1]

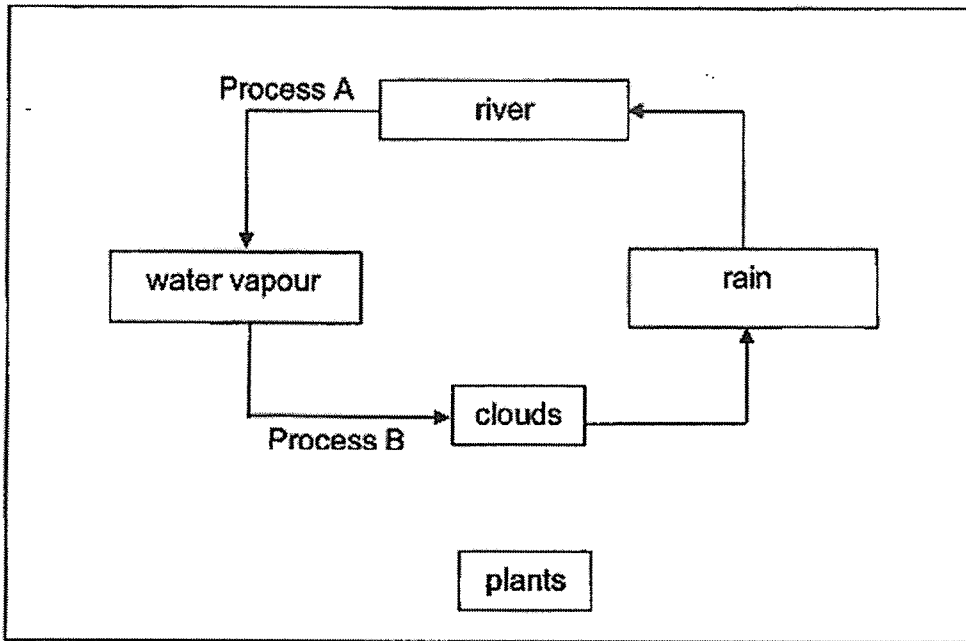

(ii) Based on the diagram of the water cycle above, complete the table below. [2]

	Process A	Process B
Name of Process		
Does water gain or lose heat?		

(b) Four similar cups, P, Q, R and S, were filled with the same amount of water at different temperatures. The cups were then placed on the table for five minutes. Water droplets were formed.

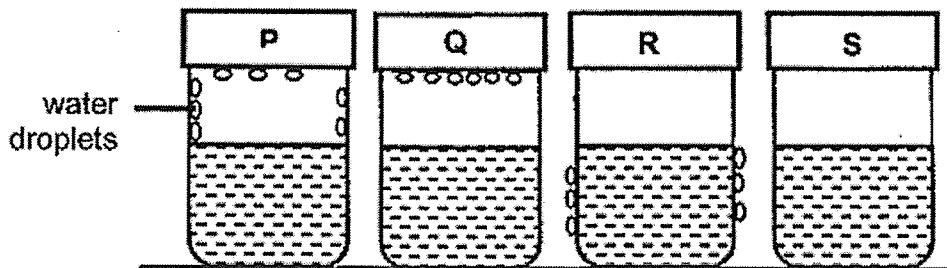

Which cup/s (P, Q, R or S) is/are most likely to contain water at room temperature?

Cup/s _____

[1]

37. Peggy set up an electrical circuit as shown below.

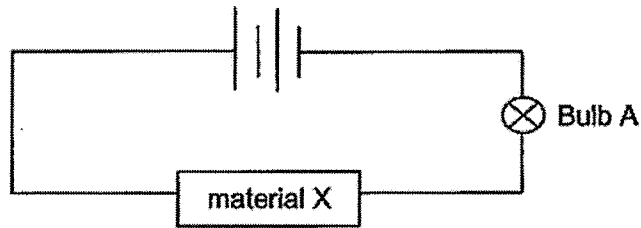

(a) Bulb A lit up. State a possible material for X. [1]

(b) Peggy replaced material X with another Bulb B at the same circuit. Both Bulb A and Bulb B lit up when the circuit was closed. What would happen to the **brightness** of Bulb A as compared to the first experiment in (a)? **Circle** your answer below. [1]

Increase

Remain the same

Decrease

(c) Draw a circuit diagram in the box below such that both bulbs A and B would be brighter than when they are in (b) by using some wires, bulbs A and B and two batteries. [1]

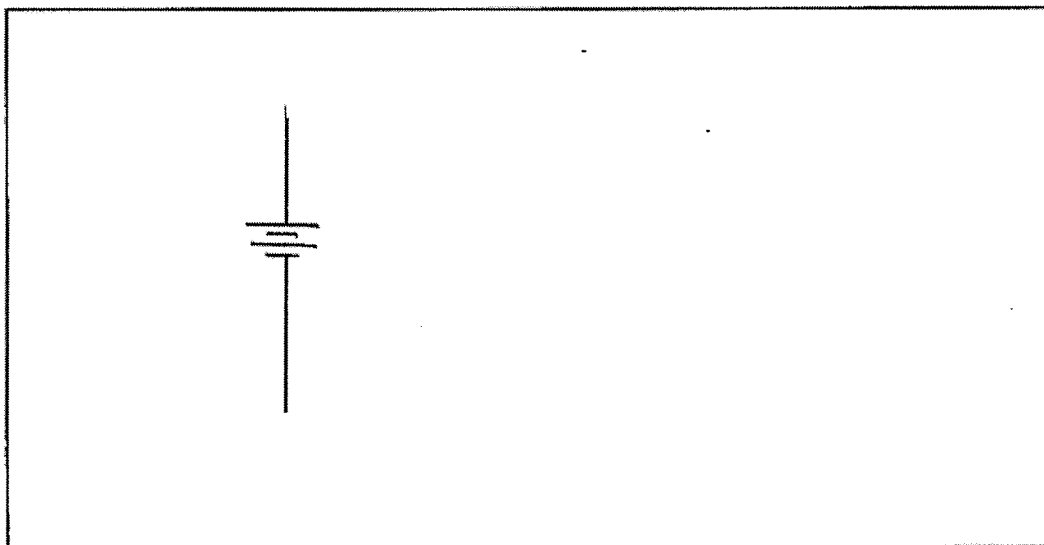

38. Two blocks of the same volume, a metal block and a plastic block, were placed into a freezer of temperature 0°C for a week as shown below.

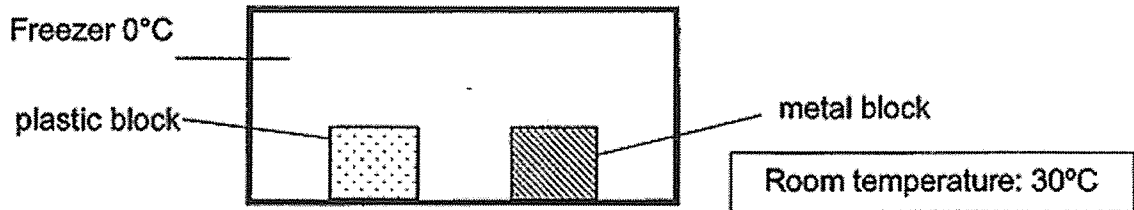

Pei Hwa recorded the temperatures of both blocks after a week.

- (a) Put a tick in the table below to indicate the temperature of each block in the freezer after one week. [1]

	Temperature of the block		
	0°C	10°C	30°C
Plastic block			
Metal block			

- (b) The blocks were then taken out of the freezer and placed on the table. Which block, plastic or metal, will reach room temperature first? Explain your answer. [2]

39. (a) State how heat travels.

[1]

(b) Adrian conducted an experiment using four similar amount of wax, A, B, C and D, on a metal ring. They were placed at different positions on the ring as shown below.

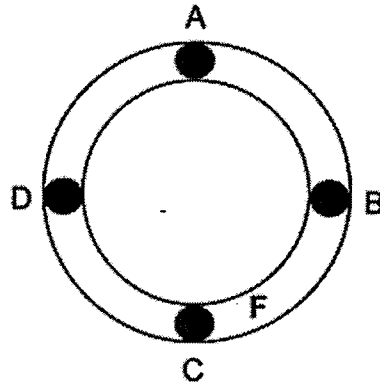

(i) A flame is placed at position F. State the order in which the wax will start to melt, starting with the first.

[1]

First drop of wax to melt \longrightarrow Last drop of wax to melt

--	--	--	--

(ii) If the metal ring is changed to a ceramic ring, will the drops of wax melt sooner or later? Explain your answer.

[2]

(c) If Adrian wanted all the wax, A, B, C and D, to melt at the same time, indicate the position where Adrian should place the flame.

Circle the correct **W** on the diagram below to indicate the position of the flame. [1]

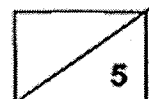
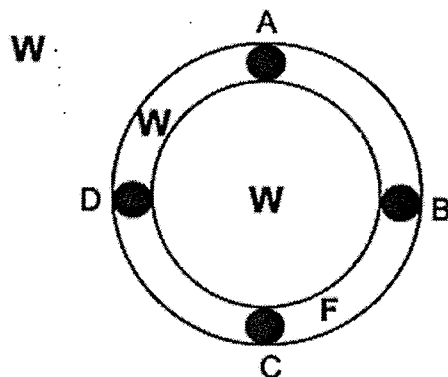

SCHOOL : SCGS PRIMARY SCHOOL
LEVEL : PRIMARY 5
SUBJECT : SCIENCE
TERM : 2022 SA2

SECTION A

Q 1	Q2	Q3	Q4	Q5	Q6	Q7	Q8	Q9	Q10
1	1	2	3	3	2	4	1	2	3
Q 11	Q12	Q13	Q14	Q15	Q16	Q17	Q18	Q19	Q20
1	3	2	2	4	3	4	2	3	3
Q 21	Q22	Q23	Q24	Q25	Q26	Q27	Q28		
2	3	4	3	4	3	1	4		



Name: _____ () Class: _____

SINGAPORE CHINESE GIRLS' SCHOOL
SA2 2022 PRIMARY 5 SCIENCE

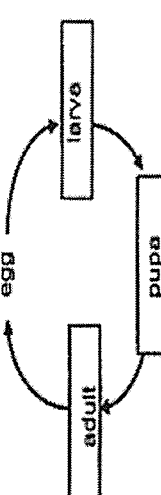
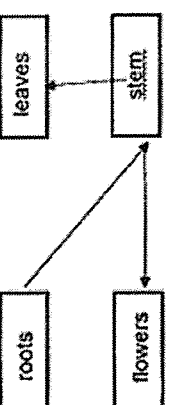
S/N	Answers
29a	<p>(i) The roots grow first as it needs to absorb water/ take in water for germination. (ii) Seed leaf OR seed leaves</p>
29b	<p>i)</p>  <p>ii) The butterfly helps to pollinate the flowers of the plant.</p>
30a	
30b	<p>(i) Increase (ii) The width increased because the food could not be transported down below W as the food-carrying tubes were removed. (iii) The roots of the tree died as they could not receive any food from the leaves/ food from the leaves could not be transported to the roots. (iv) The leaves could not make food and died because they could not get any water as the roots have died and could not take in water.</p>
31a	<p>Jolene's heart rate increases when the time taken for her exercise increases.</p>

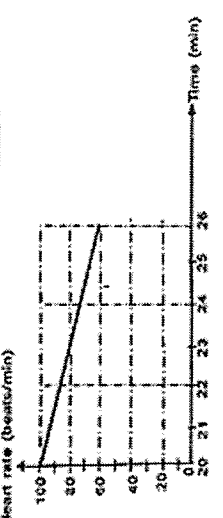
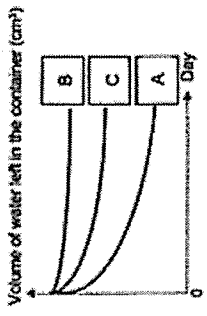
S/N	Answers						
31b	<p>Oxygen from the surrounding air is taken in by the lungs and is absorbed by the blood which carries it to the heart to be pumped to the legs.</p>						
31c							
32a							
32b	<p>Set-up A had the most number of leaves, so the roots took in/ absorbed the most amount of water and gave out the most amount of water. Water vapour through its leaves/stomata thus the least amount of water was left in the container.</p>						
32c	<p>Placing them at the same place ensures that the temperature of the surroundings/ humidity/ amount of light/ amount of wind each set-up is exposed to was the same.</p>						
33a	<table border="1" data-bbox="1117 560 1204 929"> <thead> <tr> <th>Parent plant</th> <th>Dispersal method</th> </tr> </thead> <tbody> <tr> <td>(i) ▲</td> <td>Water</td> </tr> <tr> <td>(ii) ●</td> <td>Wind</td> </tr> </tbody> </table> <p>(iii) Its seedlings are found along the river bank/ sides of the river.</p>	Parent plant	Dispersal method	(i) ▲	Water	(ii) ●	Wind
Parent plant	Dispersal method						
(i) ▲	Water						
(ii) ●	Wind						
33b	<p>(i) They are dispersed by animals. (ii) Fruit F attaches/ hooks onto animals' fur/ hair and drops off at a different place.</p>						

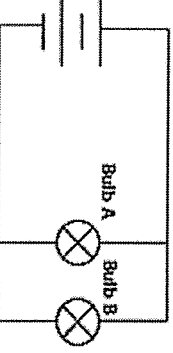
S/N	Answers						
34a	Food /glucose /sugar and oxygen						
34b	Beaker with leaf X. Leaf X is only painted on top surface but leaf Y is painted only on the bottom. As the bottom has more stomata, this means leaf X has more stomata exposed/unblocked. Thus, when leaf X photosynthesizes/make food under the sun, it gives out more oxygen as bubbles than leaf Y. (iii) All variables are ticked except 'Amount of air bubbles'						
35a	a) has digestive juices / can digest food aii) does not have digestive juices/ cannot digest food						
35b	Saliva						
35c	Our teeth helps to break the food into smaller pieces thus the food has more (surface) area in contact with the digestive juice, allowing the food to digest faster. Note – Definition of 'Digestion' - Break down food into simpler substances. Teeth cannot 'break down' food as teeth cannot digest food. Teeth can 'break up' food into smaller pieces.						
36a	One arrow from rain to plants (i) One arrow from plants to water vapour						
36a	(ii)						
	<table border="1"> <thead> <tr> <th>Process A</th> <th>Process B</th> </tr> </thead> <tbody> <tr> <td>Evaporation</td> <td>Condensation</td> </tr> <tr> <td>Gains heat</td> <td>Loses heat</td> </tr> </tbody> </table>	Process A	Process B	Evaporation	Condensation	Gains heat	Loses heat
Process A	Process B						
Evaporation	Condensation						
Gains heat	Loses heat						
36b	S						
37a	Any specified material that is a conductor of electricity, example. Iron, copper, silver, gold, lead, carbon						
37b	Decrease Answer is not exhaustive.						
37c							

3

S/N	Answers
38a	Tick both at 0°C.
38b	Metal reaches room temperature (from 0°C) first as metal is a better conductor of heat than plastic. Thus metal can gain heat faster from the surrounding/ Heat can be conducted faster from surroundings to metal.
39a	Heat travels from a hotter place to a cooler place.
39b	C B D A
39c	Ceramic is a poorer conductor of heat than metal, so it will conduct heat slower from the flame/ heat source to the wax, so the wax will melt slower. Choose the 'W' in the middle of the ring.

4