

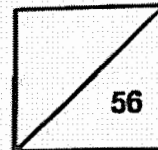

Rosyth School  
End-of-Year Examination 2022  
**SCIENCE**  
Primary 5

Name: \_\_\_\_\_

Total  
Marks:



Class: Pr 5- \_\_\_\_\_

Total time for Booklets A and B: 1 h 45 min

Date: 28 October 2022

---

## Booklet A

Instructions to Pupils:

1. Do not open the booklet until you are told to do so.
2. Follow all instructions carefully.
3. This paper consists of 2 booklets, Booklet A and Booklet B.
4. For questions 1 to 28 in Booklet A, shade the correct ovals on the Optical Answer Sheet (OAS) provided using a 2B pencil.

\* This booklet consists of 22 printed pages (including cover page).

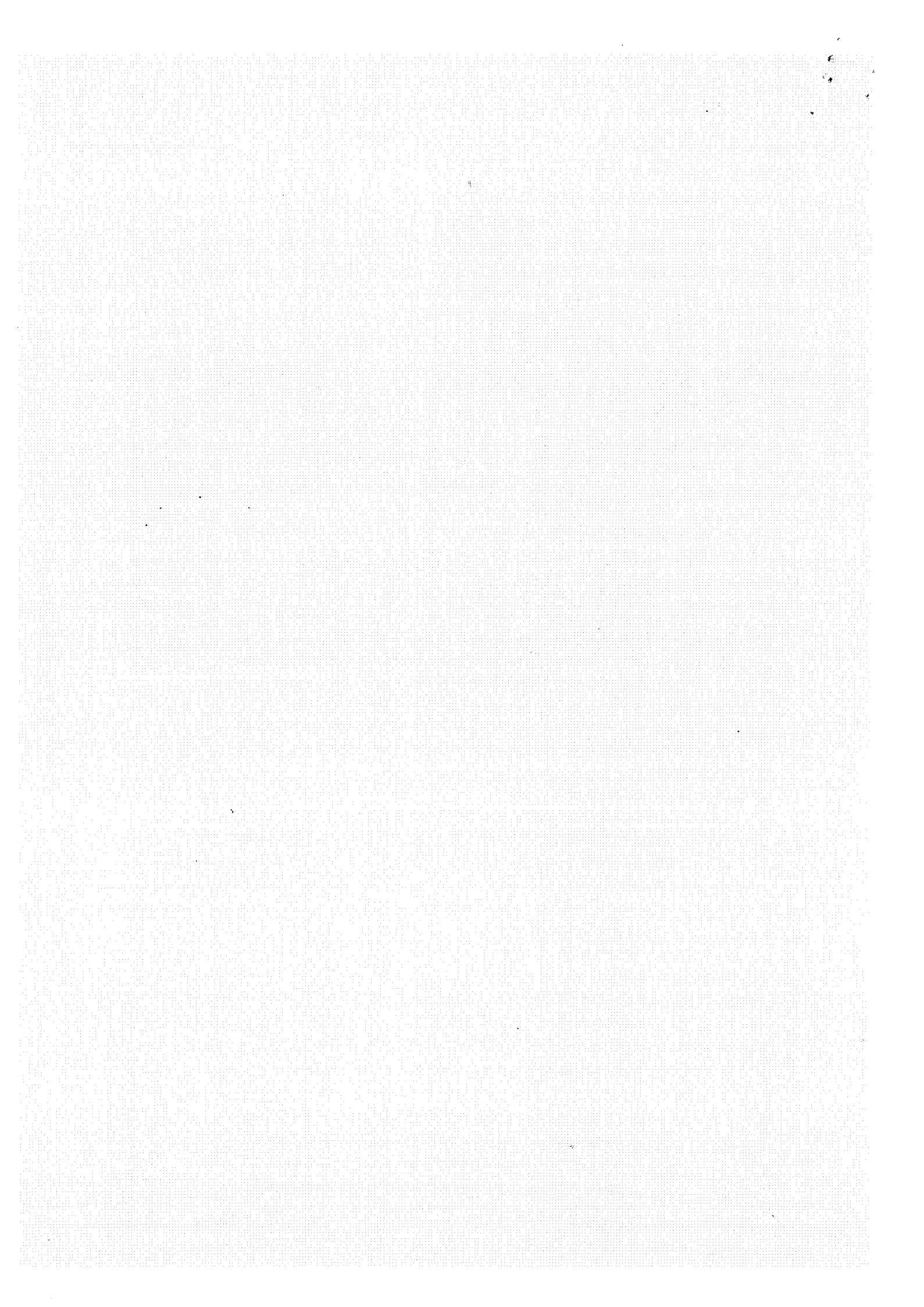

For each question from 1 to 28, four options are given. One of them is the correct answer. Make your choice (1, 2, 3 or 4). Shade the correct oval (1, 2, 3 or 4) on the Optical Answer Sheet. (56 Marks)

---

1 Which of the following are made of cells?

A: cat

B: moon

C: teddy bear

D: tomato plant

(1) A and B only

(2) A and D only

(3) B and C only

(4) C and D only

2 A certain substance found in the cells of a firefly responsible for glowing is transferred into some mice. It was observed the young of those mice can glow in darkness.

In which part of the cell the substance responsible for glowing was transferred into the mice?

(1) nucleus

(2) cytoplasm

(3) chloroplast

(4) cell membrane

- 3 Daniel introduced a population of microorganism A into a pond. Microorganism A can move in the water.

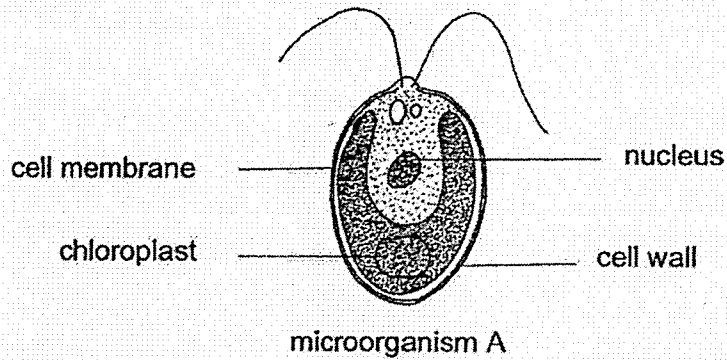

The pond was situated in a bright place. W, X, Y and Z, represent different parts in the pond.

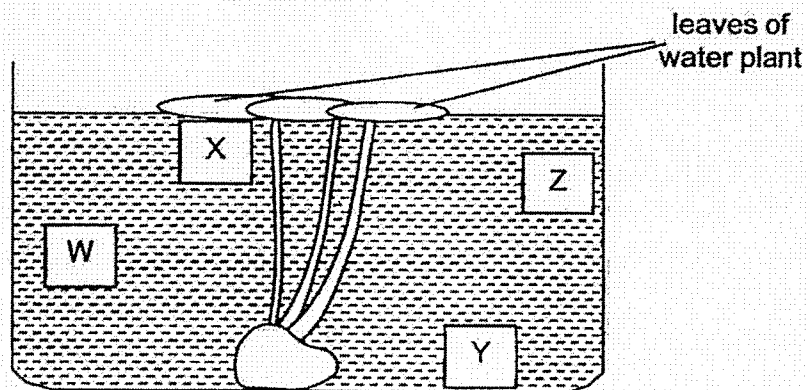

Based on the information given, in which part of the pond would the microorganism A make the most food?

- (1) W
- (2) X
- (3) Y
- (4) Z

- 4 The diagram below shows a plant.

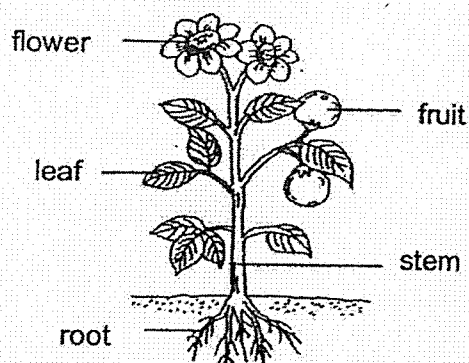

Which parts of the plant will food made in the leaves be transported to?

- (1) stem and roots only
- (2) stem and flower only
- (3) stem, flower and fruit only
- (4) stem, flower, fruit and root

- 5 The diagram below shows the side view of a leaf cell and two different types of tubes found in the stem. M and N are substances that are transported along the tubes into and out of the leaf cell in the day as shown below.

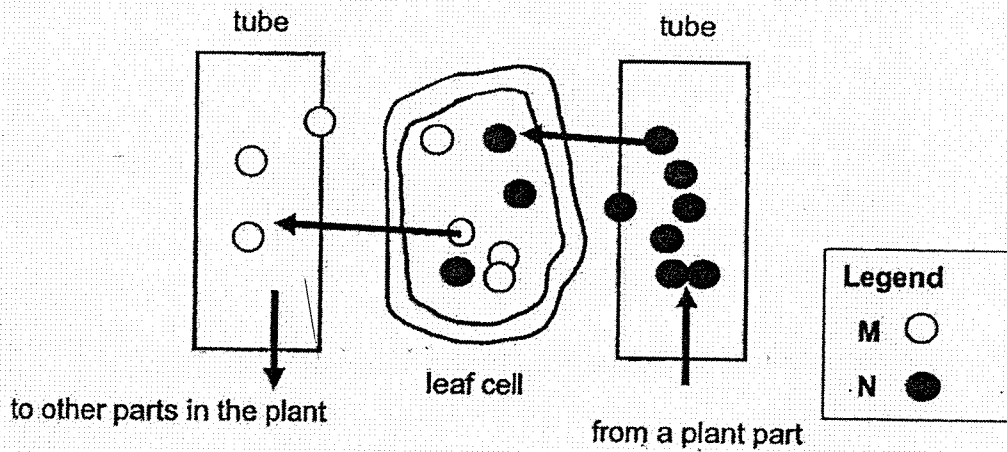

What could substances M and N be?

	M	N
(1)	sugar	carbon dioxide
(2)	starch	water
(3)	oxygen	carbon dioxide
(4)	sugar	water

6 Susan wants to show that celery has water-carrying tubes to transport water to the leaves.

Which one of the following should she use as an experimental set-up?

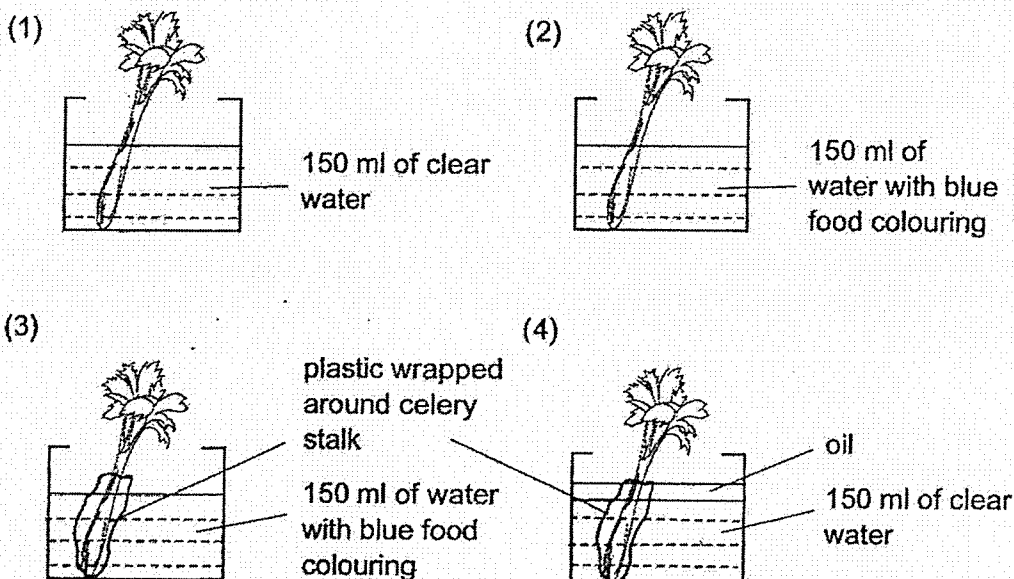

7 Which of the following statements about the different human systems is not correct?

- (1) Respiratory system carries out gaseous exchange.
- (2) Respiratory system is made up of nose, windpipe and lungs.
- (3) Circulatory system transports substances such as water, digested food and oxygen to all parts of the body.
- (4) Digestive system breaks down food into simple substances in the mouth, stomach, small intestine and large intestine.

8 Read the following statements about inhaled air and exhaled air in a human. Which one of the statements is correct?

- (1) Exhaled air contains no oxygen.
- (2) Exhaled air contains only carbon dioxide.
- (3) Inhaled air contains more oxygen than nitrogen.
- (4) Inhaled air contains more oxygen than exhaled air.

9 Four blood samples were collected from different blood vessels in the body. The following graph shows the amount of carbon dioxide in each of the blood samples.

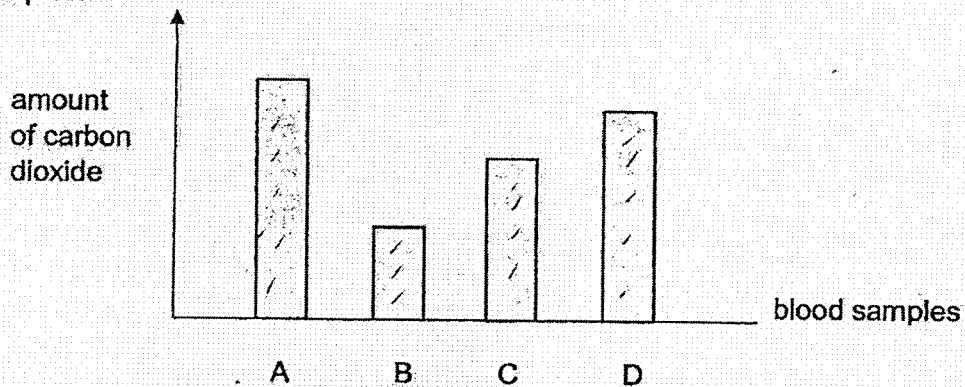

Which one of the blood samples is most likely taken from the blood vessel carrying blood from the heart to the lungs?

- (1) A
- (2) B
- (3) C
- (4) D



- 10 Ally studied the graph that shows the relationship between the temperature of water and the amount of dissolved oxygen in water.

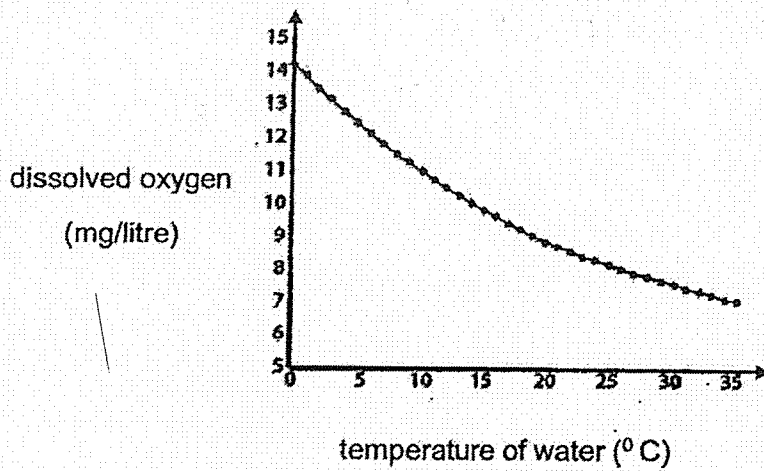

Ally observed another graph below which shows the average number of times the gill covers of a guppy open and close on four different days to obtain enough oxygen.

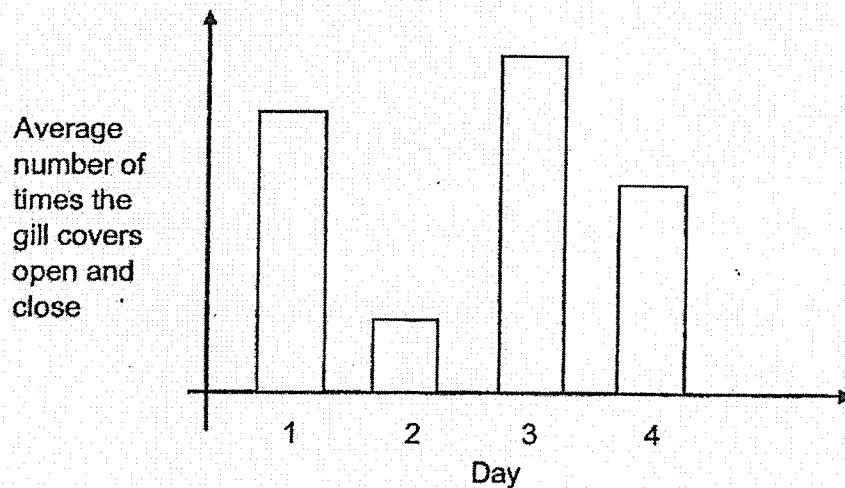

Based on the two graphs, on which day was the temperature of water the highest?

- (1) Day 1
- (2) Day 2
- (3) Day 3
- (4) Day 4

11 Which of the following statements about reproduction in human is not correct?

- (1) An egg is fertilised by one sperm.
- (2) Fertilised egg travels to the womb.
- (3) Eggs are produced and stored in the ovaries.
- (4) Pollination must take place before fertilisation.

12 The diagram below shows a human and plant reproductive systems.

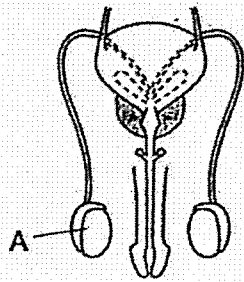

human reproductive system

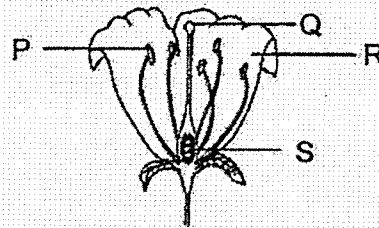

plant reproductive system

Which part, P, Q, R or S, has the same function as part A?

- (1) P
- (2) Q
- (3) R
- (4) S

13 The diagram below shows developmental stages of a flowering plant.

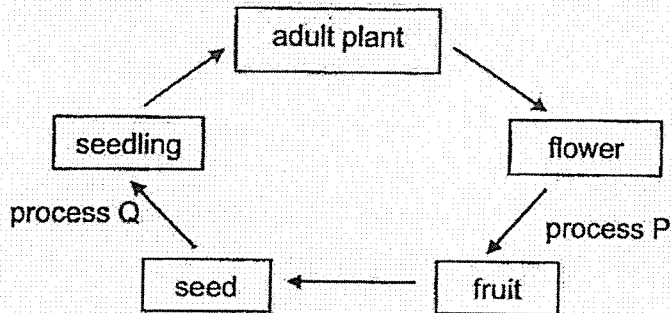

Which of the following shows the processes, P and Q, that would occur just before the next developmental stage is formed?

	Process P	Process Q
(1)	pollination	germination
(2)	fertilisation	dispersal
(3)	pollination	dispersal
(4)	fertilisation	germination

14. The table below shows the characteristics of two plants, X and Y.

Plant	Characteristics	
	reproduce by seeds	dispersed by wind
X	✓	✓
Y	x	✓

From the information given above, identify the groups that plants X and Y belong to as shown in the classification chart below.

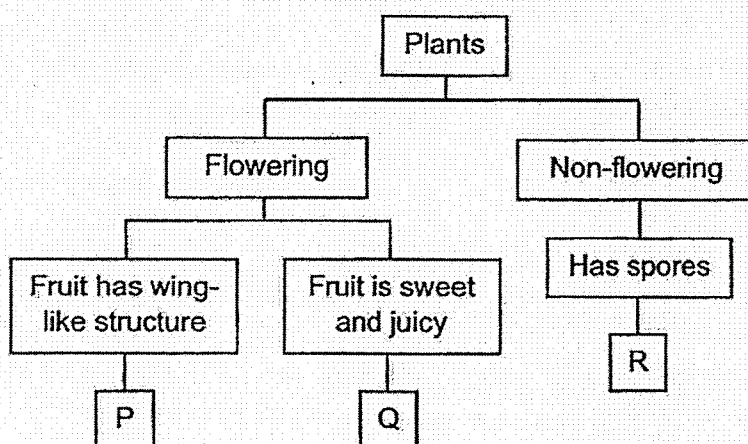

	Plant X	Plant Y
(1)	R	Q
(2)	P	R
(3)	P	Q
(4)	Q	P

15 In which of the following circuits will the bulb most likely light up?

(1)

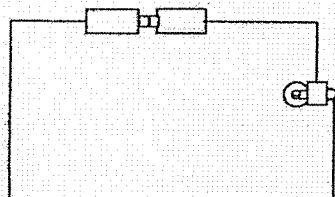

(2)

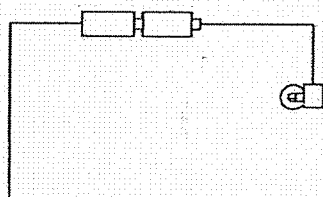

(3)

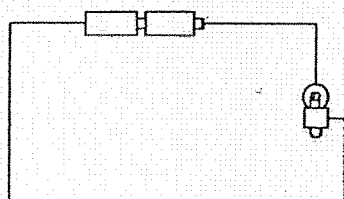

(4)

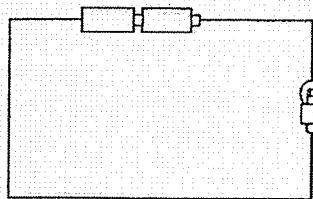

16 Alice sets up an electric circuit as shown below.

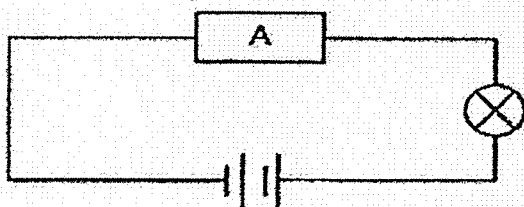

Which one of the following materials could object A be made of to light up the bulb?

- (1) iron
- (2) wood
- (3) plastic
- (4) rubber

- 17 Alan set up four circuits to find out the conductivity of four different materials, A, B, C and D, as shown below.

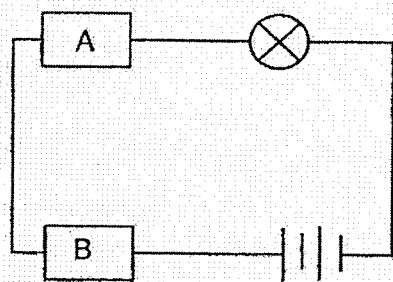

Circuit P

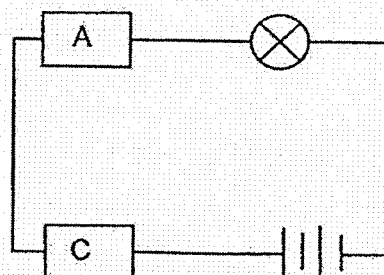

Circuit Q

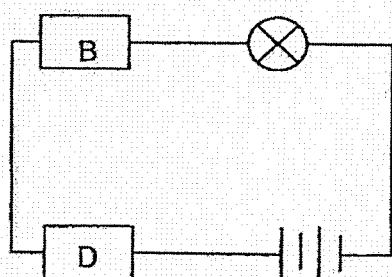

Circuit R

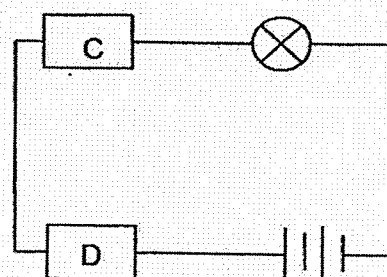

Circuit S

Only the bulbs in circuit Q and S lit up. Based on his observation, which of the following correctly identifies the non-conductor/s of electricity?

- (1) A only
- (2) B only
- (3) A and C only
- (4) B, C and D only

- 18 Alicia investigated to find out what would happen when electric current was passed into plants. She recorded the average height of plants in a graph as shown below.

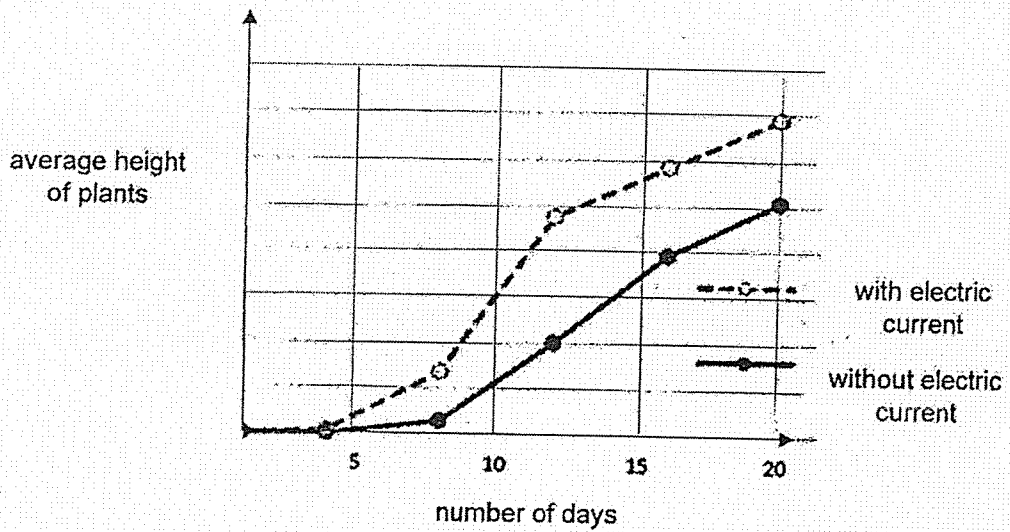

Explain why the set-up without electric current is needed in her experiment.

- (1) To ensure that the experiment is fair
- (2) To ensure that the results are reliable
- (3) To use the results to find the average height of the plants
- (4) To use the results for comparison to confirm the conclusion

- 19 A beaker of water was heated over a heat source. The water boiled and bubbles were formed throughout the water.

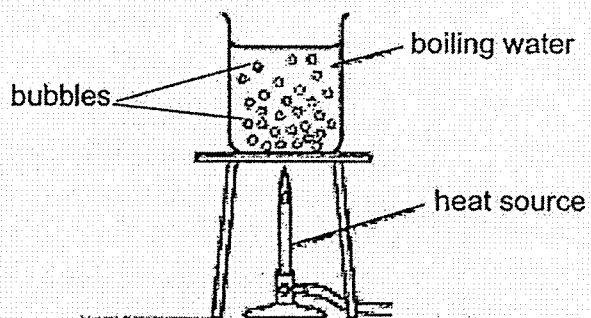

What do the bubbles consist of?

- (1) Oxygen only
- (2) Nitrogen only
- (3) Water vapour only
- (4) Carbon dioxide only



20 The diagram below shows the water cycle at a river.

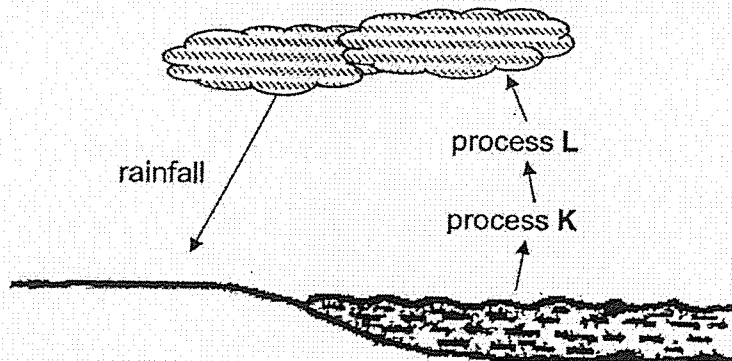

Which of the following correctly identifies processes K and L?

Process	
K	L
(1) condensation	evaporation
(2) evaporation	evaporation
(3) evaporation	condensation
(4) condensation	condensation

- 21 Mrs Sitoh placed some ice cubes in a closed box. After some time, the ice melted as shown in the diagram below.

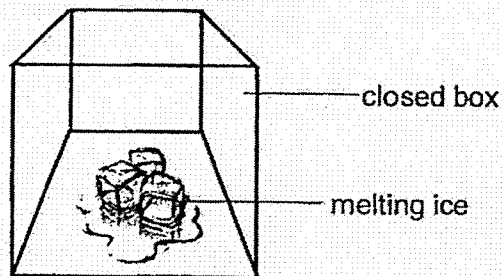

Which of the following correctly shows the temperatures of air in the box and the melting ice?

Temperatures of	
air in the box	melting ice
(1) remains the same	increases
(2) increases	remains the same
(3) decreases	remains the same
(4) decreases	increases

- 22 Which one of the followings shows the immediate effects of heat gain and heat loss of water correctly?

	Heat gain	Heat loss
(1)	Misty fans for people to feel cooler	Drying of clothes
(2)	Water dripping from a rice cooker cover	White clouds above a hot kettle
(3)	Dew on leaves	Puddle of water drying up
(4)	Wet towel on forehead to bring down fever	Mirror gets foggy after a hot shower

- 23 The table below shows the state of three substances, A, B and C, at different temperatures.

Substance	State of substance at		
	5°C	25°C	50°C
A	solid	solid	solid
B	solid	liquid	liquid
C	liquid	liquid	liquid

Which of the following statements is correct?

- (1) Substance C has the lowest boiling point.
- (2) Substance A has the highest melting point.
- (3) Freezing point of substance B is below 5°C.
- (4) Melting point of substance B is above 50°C.

- 24 Jia Le conducted the following experiment.

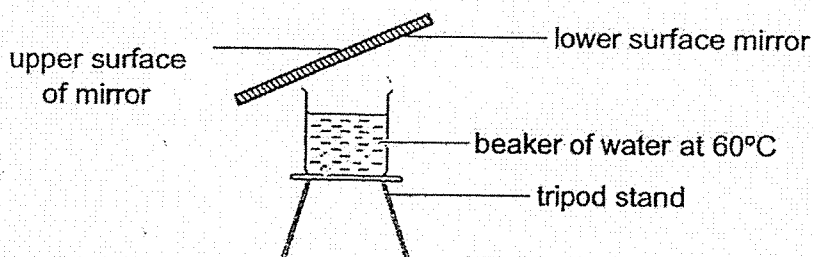

Which of the following will most likely result in an increase in the amount of water droplets formed on the mirror?

- (1) Remove the tripod stand
- (2) Add ice to the beaker of water
- (3) Place a cold towel on the upper surface of mirror
- (4) Place a hot towel on the lower surface of mirror

- 25 Luke placed four identical plastic containers, A, B, C and D, containing equal amounts of water in a freezer. After five hours, he took the four containers out of the freezer and placed each of them on a dish as shown below.

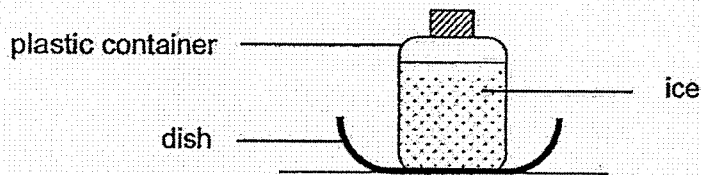

He left the plastic containers at different locations and recorded the amount of water collected on the dishes after fifteen minutes in the table below.

Container	A	B	C	D
Amount of water collected in the dish (cm <sup>3</sup> )	3	12	6	9

Based on Luke's results, which one of the following shows the correct order of the temperature of the location where the containers were placed?

	Lowest temperature	Highest temperature
(1)	D	A
(2)	B	A
(3)	A	B
(4)	C	B

- 26 The diagram below shows two substances, J and K, in similar containers. Each container has a capacity of  $300 \text{ cm}^3$  and contained  $250 \text{ cm}^3$  of J or K.

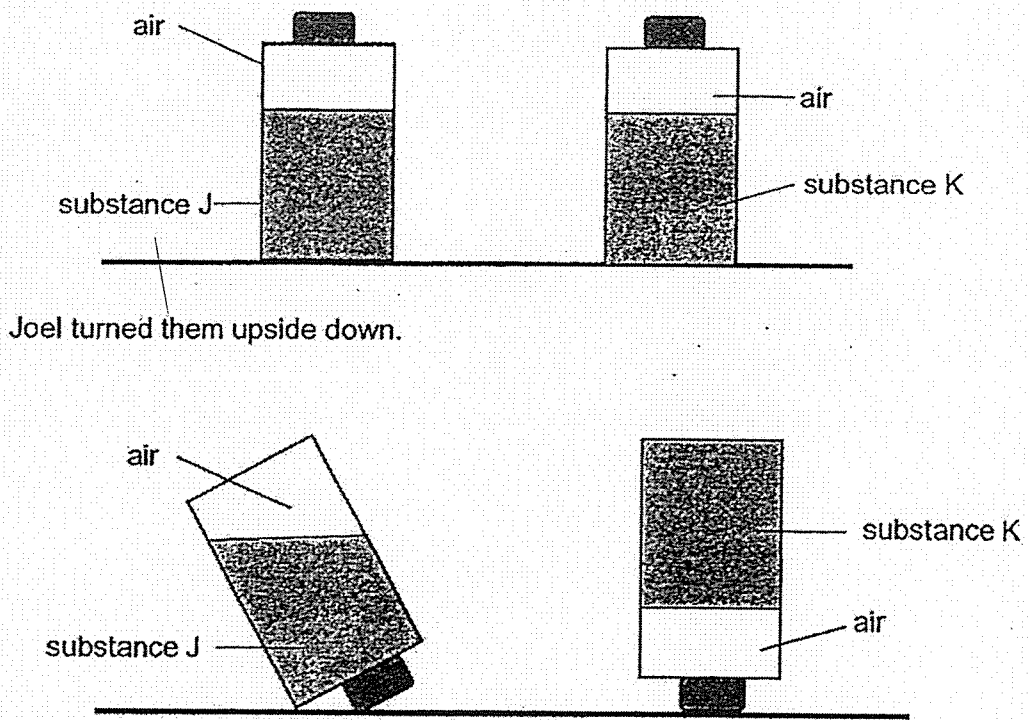

Based on the above diagram, which of the following statement is definitely false?

- (1) Substance J is oil
- (2) Substance K is a solid.
- (3) Substance J has a definite volume.
- (4) Substance K has no definite shape but has definite volume.

- 27 In the set-up as shown below, the empty flask has a capacity of  $600 \text{ cm}^3$ .  $100 \text{ cm}^3$  of water is then poured in. A syringe is used to pump air into the flask. Air pumped into the flask cannot escape due to the special valve. Each time the plunger is completely pushed in,  $20 \text{ cm}^3$  of air enters the flask.

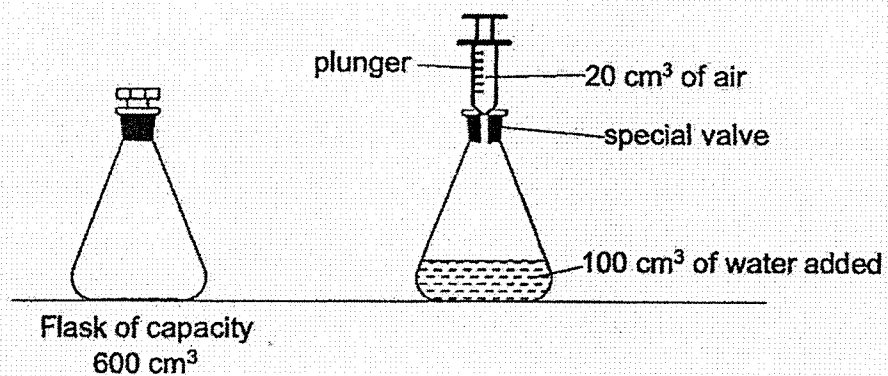

What would be the final volume of air in the flask when the plunger is pushed ten times?

- (1)  $200 \text{ cm}^3$
- (2)  $500 \text{ cm}^3$
- (3)  $600 \text{ cm}^3$
- (4)  $800 \text{ cm}^3$

- 28 Peter put the same amount of cold water at  $10^{\circ}\text{C}$  into a styrofoam cup and a plastic vase. When he touched them, his hands felt that the plastic vase was colder than the styrofoam cup.

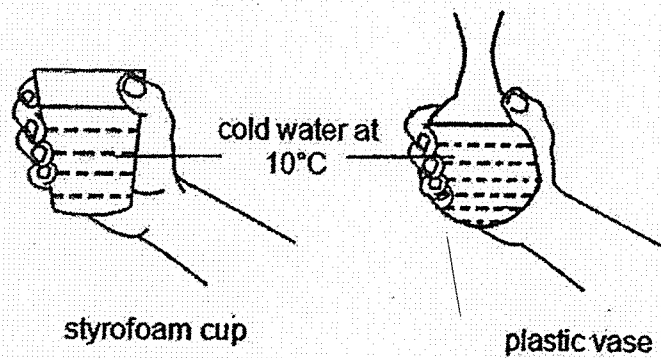

Which of the following explains why Peter's hands felt that the plastic vase was colder than the styrofoam cup?

- (1) The plastic vase gained heat slower than the styrofoam cup.
- (2) The plastic vase conducted heat faster than the styrofoam cup.
- (3) The plastic vase had a lower temperature than the styrofoam cup.
- (4) The plastic vase had more contact with the hand than the styrofoam cup.

Go to BOOKLET B

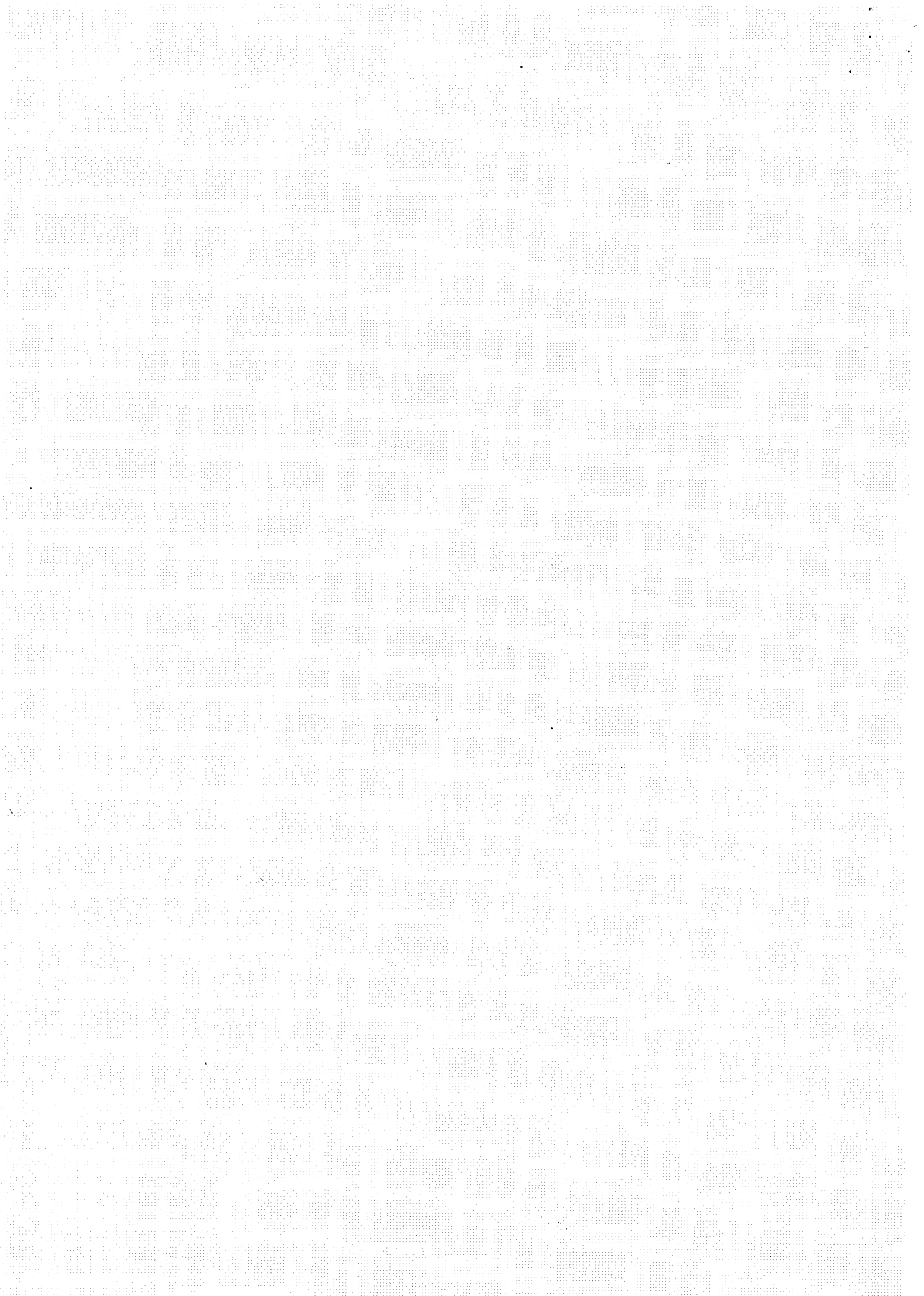





Rosyth School  
End-of-Year Examination 2022

SCIENCE

Primary 5

Name: \_\_\_\_\_

Total

Marks:

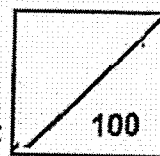

Class: Pr 5 \_\_\_\_\_ Register No. \_\_\_\_\_

Total time for booklets A & B: 1h 45min

Date: 28 October 2022

Parent's Signature: \_\_\_\_\_

---

## Booklet B

Instructions to Pupils:

1. For questions 29 to 40, write your answers in the spaces given in this booklet.

	Maximum marks	Marks Obtained
Booklet A	56	
Booklet B	44	
Total	100	

\* This booklet consists of 15 printed pages (including cover page).

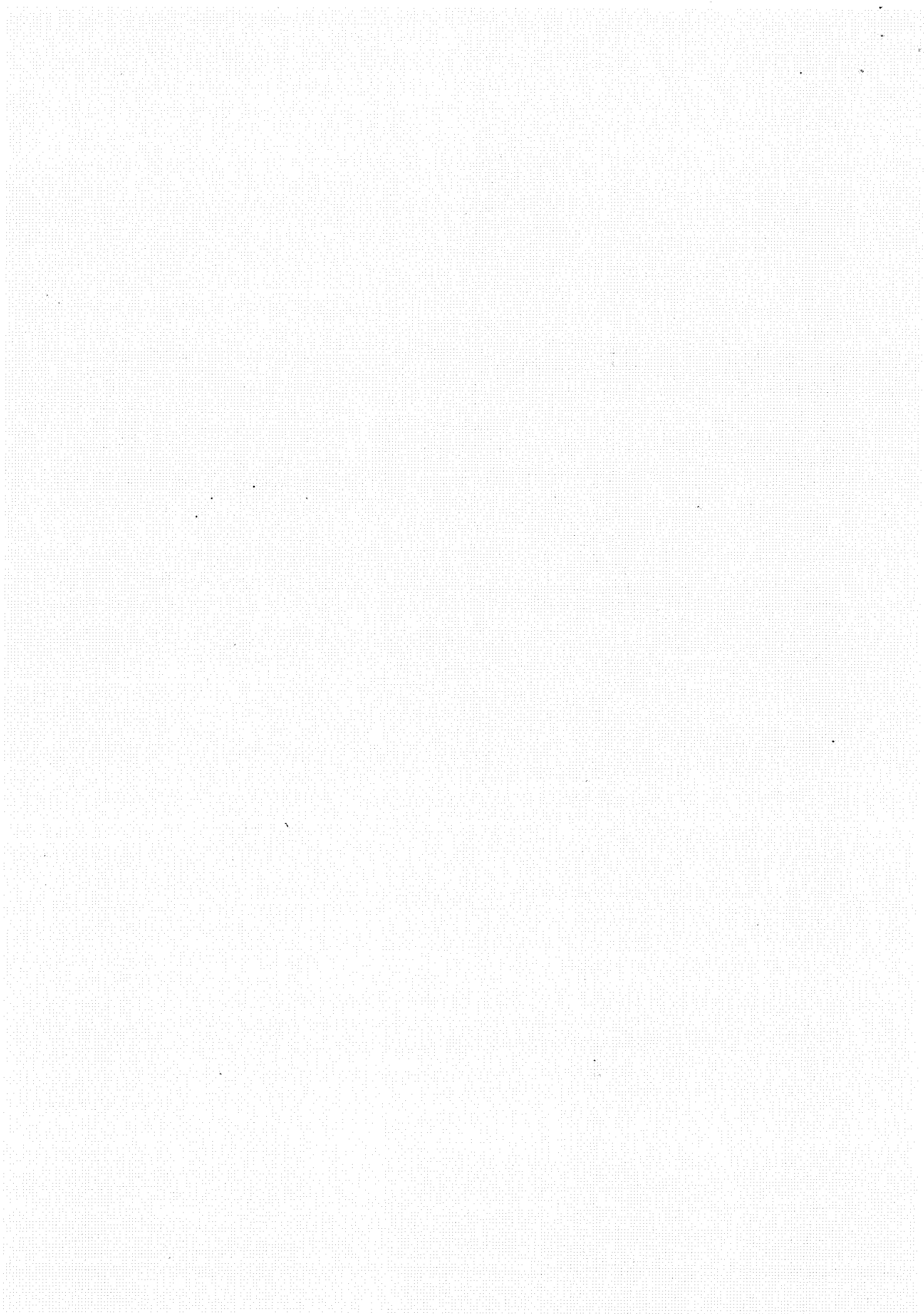

For questions 29 to 40, write your answers in the space provided. (44 Marks)

29 Richard studied the information about four cells, P, Q, R and S. A tick (✓) indicates the presence of the part of a cell.

Parts of a Cell	Cell			
	P	Q	R	S
cell membrane	✓	✓	✓	✓
chloroplast				✓
cytoplasm	✓	✓	✓	✓
cell wall	✓			✓
nucleus	✓	✓		✓

(a) Based on the information in the table above, which cell(s) is/are taken from an animal? [1]

\_\_\_\_\_

(b) Which one of the cells, P, Q, R or S, cannot reproduce? Give a reason. [1]

\_\_\_\_\_  
\_\_\_\_\_

(c) Richard claims that cell P is not taken from a leaf. Do you agree with him? Explain why. [1]

\_\_\_\_\_  
\_\_\_\_\_  
\_\_\_\_\_

- 30 Eric removed the outer ring of the bark from a mango tree as shown in the diagram below.

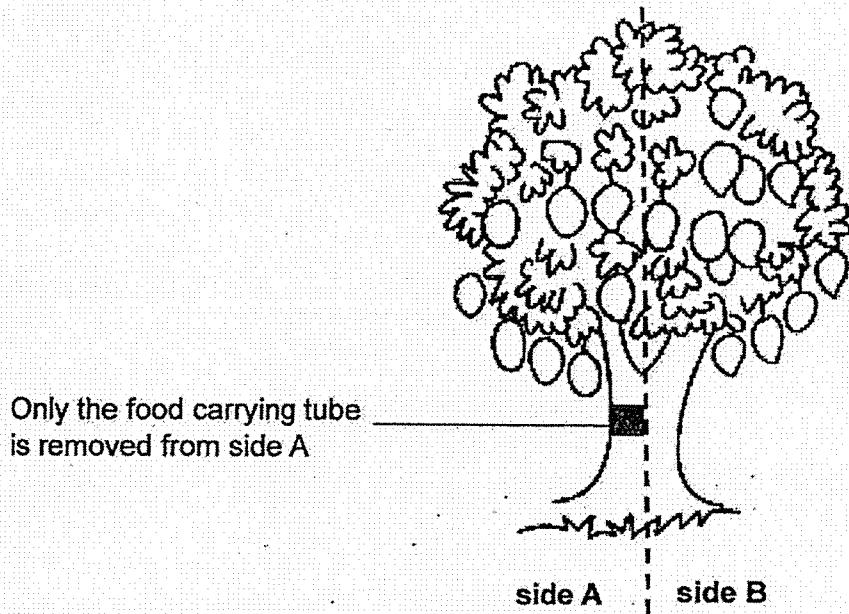

- (a) Name two substances that can still be transported to the leaves on side A. [2]

---

The diagram below shows two mangoes taken from sides A and B of the tree after 1 week.

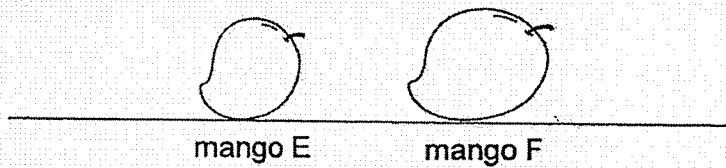

- (b) Which mango is plucked from side A? Explain your answer. [2]

---

---

---

- 31 The graph below shows how Claire's heart rate changes as she exercises on a treadmill.

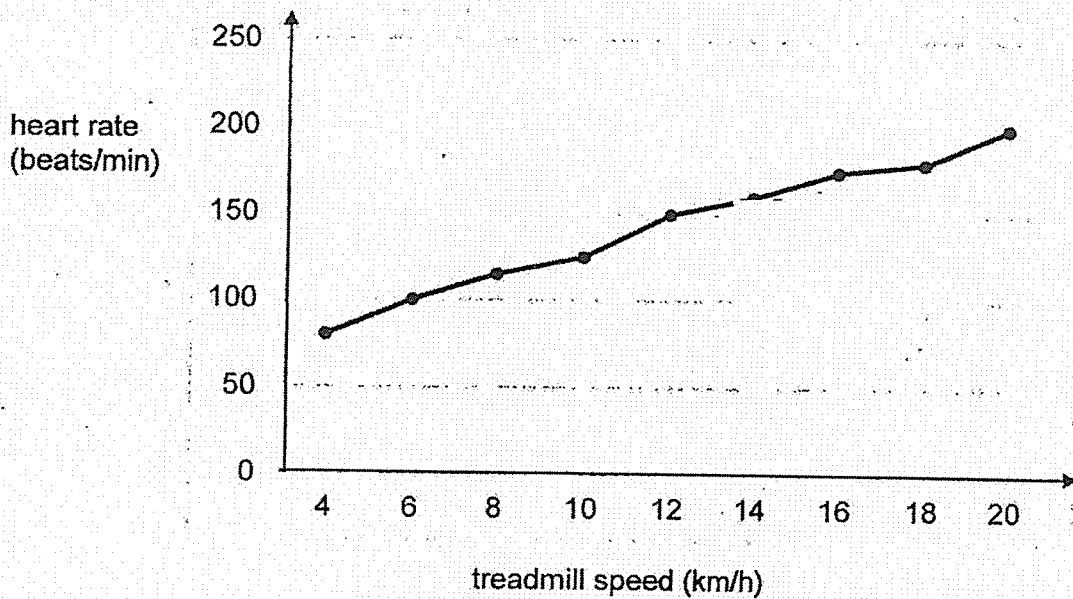

- (a) What is the relationship between the treadmill speed and the heart rate? [1]

---

---

- (b) Besides the heart, name two other parts in the human circulatory system. [1]

---

---

- (c) Based on the graph, Claire made the following inference.

"The heart beats faster during an exercise to supply the body with more blood".

Do you agree with Claire? Explain why.

[2]

---

---

---

- 32 The diagrams below show the number of plants X and Y on an island over five years.

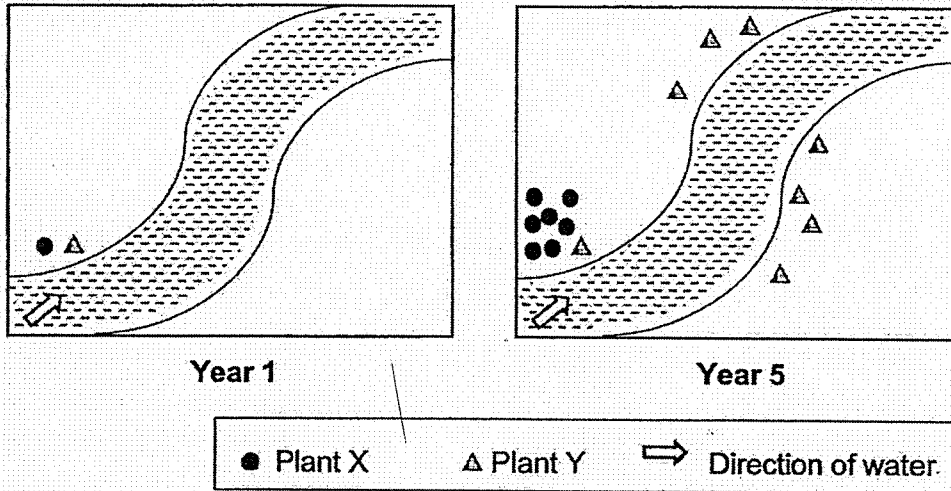

- (a) Study the two fruits below carefully.

Which of the following is likely to be the fruit of Plant Y?  
Put a tick in the box.

[1]

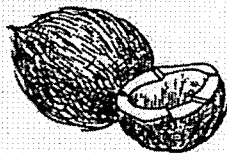



- (b) State a characteristic of the fruit of plant Y that helps in its dispersal.

[1]

---



---

- (c) The young plants of X did not grow very well. Explain why.

[2]

---



---



---

33

(a) Explain why reproduction is important.

[1]

---

---

(b) Study the pictures below. The young inherited characteristics from its parents.

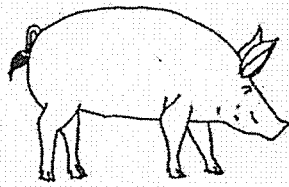

male adult

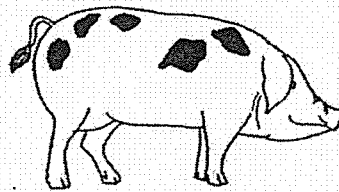

female adult

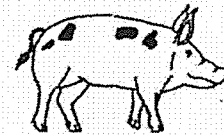

young

State one physical characteristic that the young has inherited from the female adult.

[1]

---

---

- 34 Jess wanted to find out which is the colour that bees are most attracted to. She made model flowers using different coloured cards. She placed five drops of the same sweetened water at the centre of each flower as shown below. The model flowers were left in an open field.

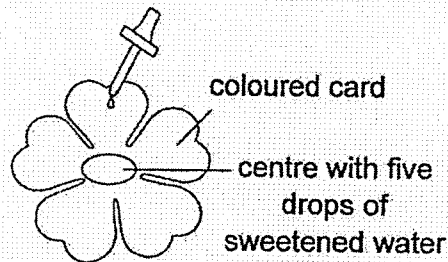

- (a) Name one other constant variable other than the conditions mentioned in the experiment above. [1]

\_\_\_\_\_

Jess then recorded the number of bees that visited the model flowers over three hours. Her results are shown below.

Colour of flower	Number of bees visiting the flower		
	1 <sup>st</sup> hour	2 <sup>nd</sup> hour	3 <sup>rd</sup> hour
purple	10	16	9
blue	6	5	3
red	1	3	1

- (b) What is the conclusion for her experiment? [1]

\_\_\_\_\_

\_\_\_\_\_

Question 34 continued on the next page



(c) Jess carried out an experiment to prove that the following hypothesis is correct.

**"Flowers can be pollinated by other flowers of the same plant naturally."**

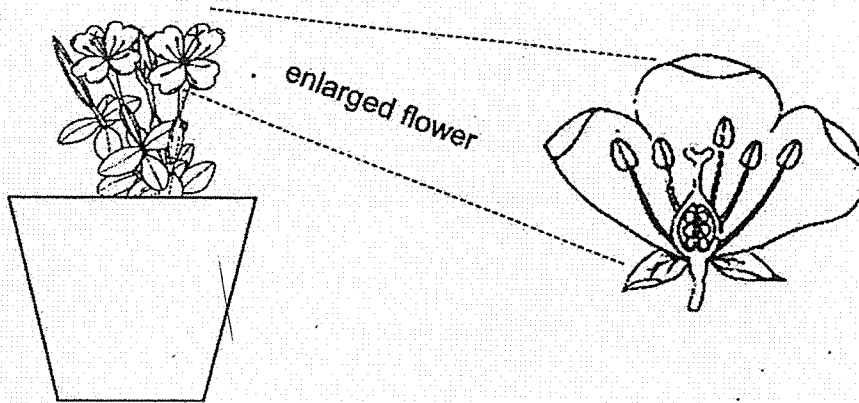

(i) Using the plant above, briefly state the steps for her experiment. [2]

---

---

---

(ii) What would she observe to prove the hypothesis correct? [1]

---

---

- 35 The diagram below shows a two-way switch. The arm of the switch can be moved to touch points, P or Q.

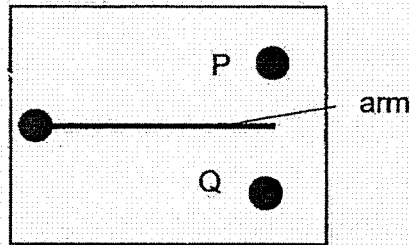

The electrical circuit shown below has two switches, 1 and 2. Both the switches are two-way switches.

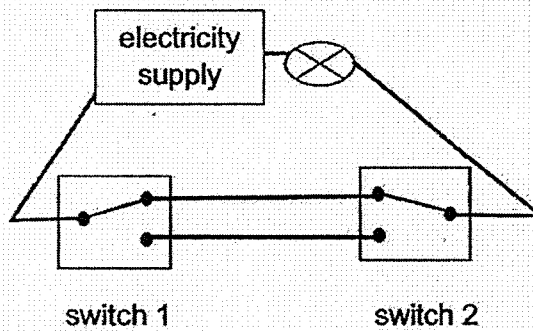

- (a) When both the switch arms are moved to touch the points as shown above, will the bulb light up? Explain why. [1]

---

- (b) What is the function of a two-way switch at a staircase and how is it useful? [2]

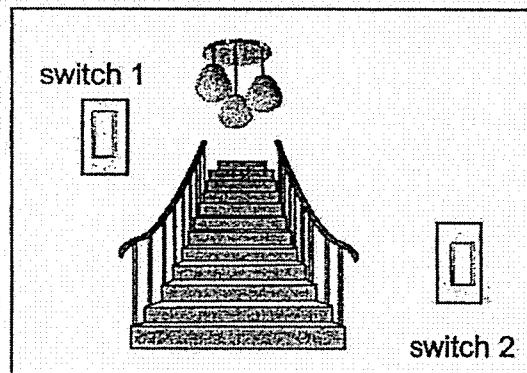

---



---



---

36 Aaron designed a toy car as shown in the diagram below.

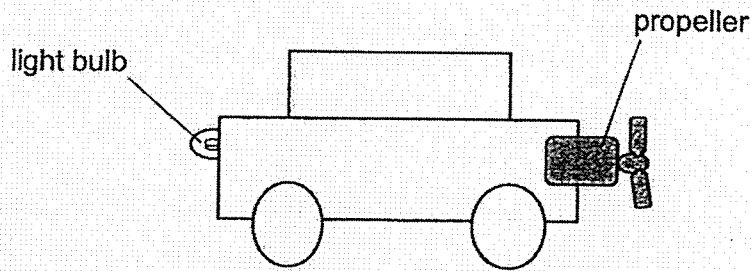

The table below shows the observations of the toy car when either or both switches, Q and R, are switched on.

Switch Q	Switch R	Observations of toy car
on	on	The propeller is moving. The light bulb is lit.
on	off	The propeller is not moving. The light bulb is lit.
off	on	The propeller is moving. The light bulb is not lit.

(a) Using wires and two switches, complete the drawing of the electrical circuit for the toy car in the box below. [3]

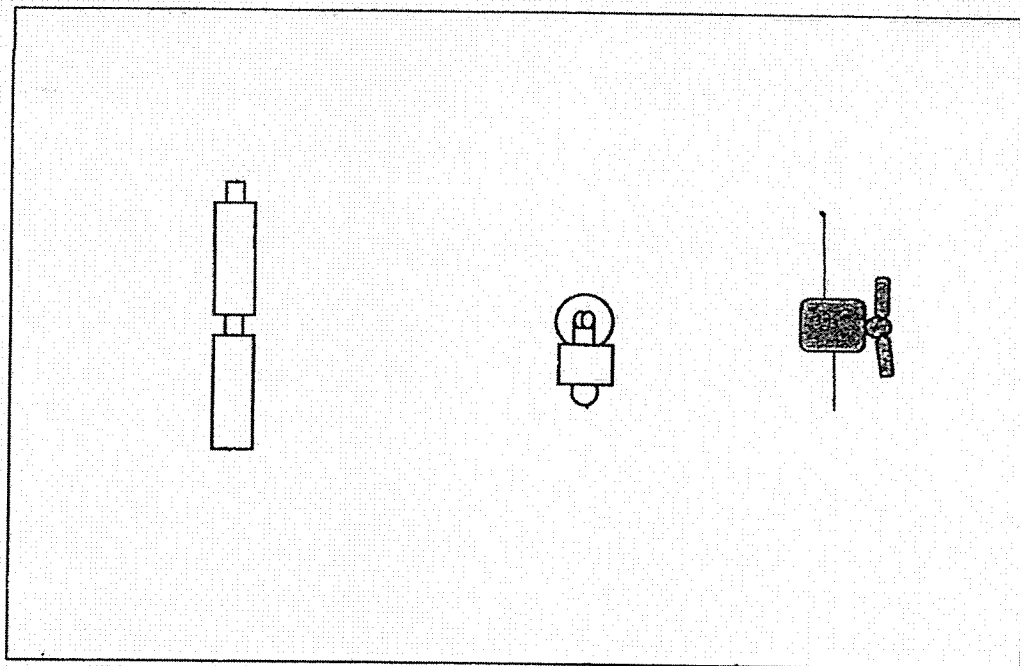

Question 36 continued on the next page

Aaron wished to make some changes in the toy car.

- (b) Suggest what Aaron should do to the electrical circuit in the toy car. [2]

	<b>Change in the Toy Car</b>	<b>Suggest what Aaron should do to the electrical circuit in the toy car.</b>
(i)	Propeller spins faster.	
(ii)	More light from two bulbs without slowing the speed of the propeller.	

- 37 Diyanah conducted an experiment using a beaker of water. She drew a graph to show the temperature of water over time as shown below.

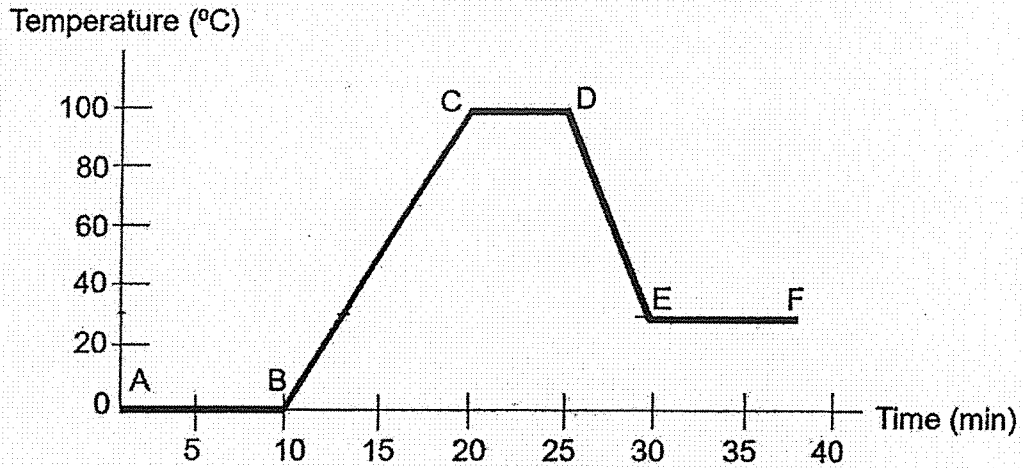

- (a) Name the processes which took place at AB and CD. [2]

AB: \_\_\_\_\_

CD: \_\_\_\_\_

- (b) Answer the following questions based on the graph: [1]

- (i) what could be the temperature of the room where the beaker is placed?

\_\_\_\_\_

- (ii) state the time of the experiment when the heat source was turned off.

\_\_\_\_\_

- 38 Raja wanted to find out if temperature of surrounding air affects the rate of evaporation. He wet two identical shirts, X and Y, with the same volume of water. He then placed two similar lamps at different distances from the shirts as shown below.

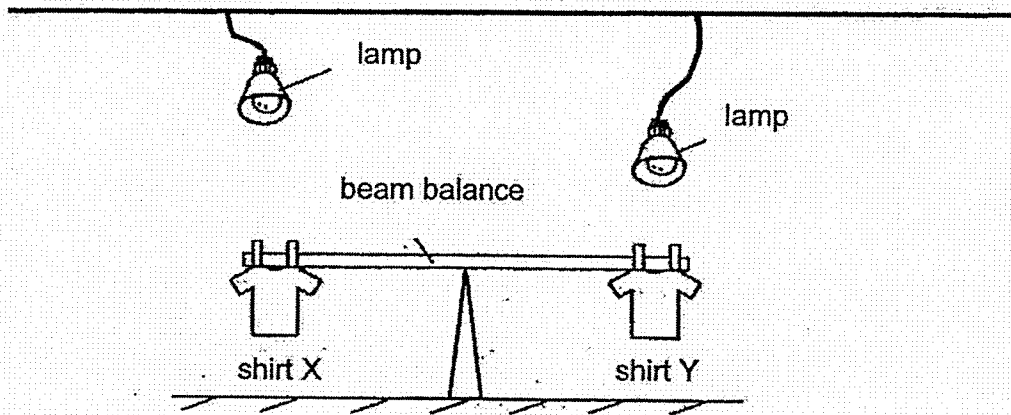

- (a) What is the purpose of the lamps in the set-up? [1]

---

---

- (b) After three hours, the beam balance <sup>tilted</sup> ~~tilted~~ downwards towards shirt X. Explain why. [2]

---

---

---

- (c) After five hours, the beam balance returned to the original position. Explain why. [1]

---

---

- 39 Jane used an electric steamer to cook some potatoes. She turned on the steamer and after some time, the water in the steamer boiled. She observed that there were many water droplets formed on the inner surface of the steamer.

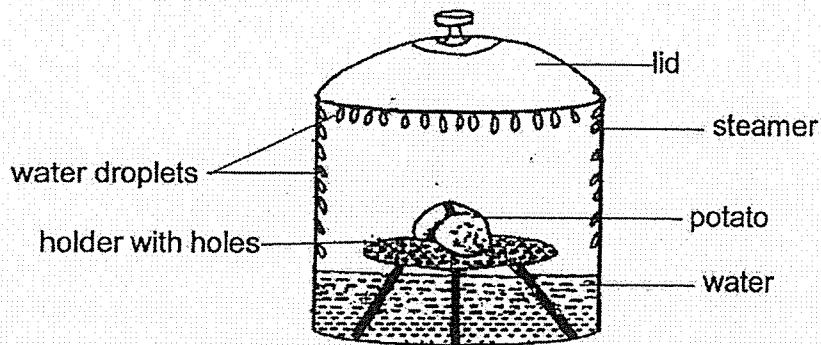

- (a) Explain how the water droplets were formed on the inner surface of the steamer.

[2]

---

---

---

- (b) Jane drives a car.

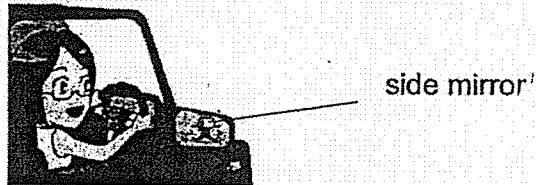

The side mirror of a car is important for her. The side mirror is fitted with heating wires inside the mirror as shown below.

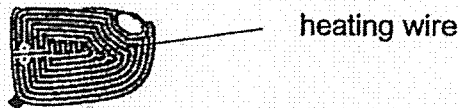

Explain how fitting with heating wires help when she drives on a rainy day. [1]

---

---

- 40 James had two cups made of the same material but different thickness. He poured 200ml of water at 55°C into each cup at the same time as shown below.

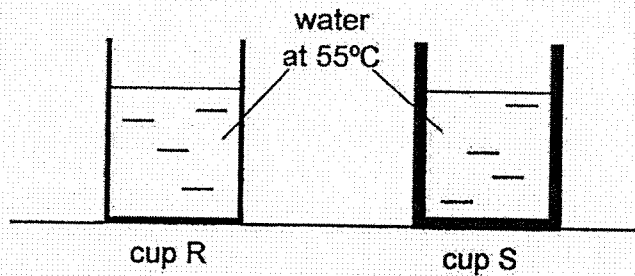

- (a) When James touched the cups, he observed that cup R felt hot immediately while it took some time for cup S to feel hot. Explain why this happened. [2]

---

---

---

James refilled the cups with water at 95 °C into the two cups, R and S, as shown below.

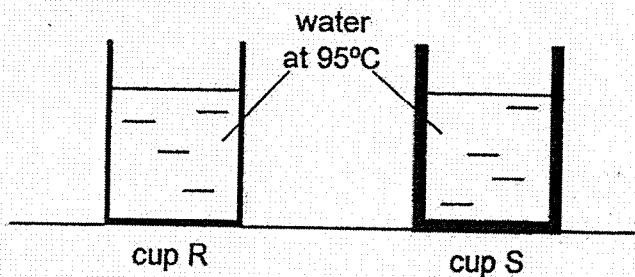

- (b) After pouring 200ml of water at 95°C into each glass cup, James observed that cup S cracked while cup R did not. Explain why cup S cracked. [2]

---

---

---

The End



YEAR : 2022  
 LEVEL : PRIMARY 5  
 SCHOOL : ROYSTH SCHOOL  
 SUBJECT : SCIENCE  
 TERM : END OF YEAR EXAMINATION

**(BOOKLET A)**

Q1	2	Q2	1	Q3	4	Q4	4	Q5	4
Q6	2	Q7	4	Q8	4	Q9	1	Q10	3
Q11	4	Q12	1	Q13	4	Q14	2	Q15	2
Q16	1	Q17	2	Q18	4	Q19	3	Q20	3
Q21	3	Q22	4	Q23	2	Q24	3	Q25	3
Q26	4	Q27	2	Q28	2				

**(BOOKLET B)**

Q29	a)	Q, R
	b)	Cell R. The cell does not have a nucleus which is needed for reproduction.
	c)	Yes, as cell P does not have chloroplast. Only leaf cells have chloroplast to make food.
Q30	a)	Water and Mineral salt
	b)	Mango F, the food-carrying tubes has been removed from side A. Hence, food made by the leaves cannot be transported below the cut. Thus, the excess food is transported to and stored in the mango, making it bigger.
Q31	a)	As the treadmill speed increases, the heart rate also increases.
	b)	Blood, Blood vessels
	c)	No, as the heart only pump blood faster. The heart pumps blood faster to send more oxygen and digested food to all parts of the body.
Q32	a)	
	b)	Fibrous husk that traps air
	c)	The young plants are near the parent plant. The young plant have to compete <sup>for</sup> sunlight, water, space and nutrients.
Q33	a)	Reproduction is important to ensure continuity of its own kind.
	b)	Black spots on the body.
Q34	a)	Size of the flower
	b)	Bees are most attracted to the colour purple.

	c)	(i)	Remove all the anthers of one flower. Have one other flower with anthers.
		(ii)	The flower without anthers will become a fruit.
Q35	a)	Yes, as it will form a closed circuit.	
	b)	The lights can be controlled independently by switch 1 and 2	
Q36	a)		
	b)	(i)	Add more batteries
		(ii)	Put the two bulbs in parallel
Q37	a)	AB : Melting CD : Boiling	
	b)	(i)	30°C
		(ii)	25 mins
Q38	a)	To increase the temperature of surrounding air.	
	b)	The lamp is further from X and the temperature of surrounding air is lower. Thus less water in shirt X gained heat and evaporated slower so X has more mass	

c) shirt x has also dried up and now both shirt are of the same mass.

Q39	a)	Water in the potato gained heat to become water vapour. Water vapour came in contact with the cooler surface of the lid, lost heat and condenses to form water vapour.
	b)	The heating wires keeps the side mirror hot and when rain touches the hotter surface, they will evaporate to form water vapour
Q40	a)	Cup S the glass is thicker so the heat travels from the hot water to the hand slower.
	b)	The inner surface of Cup S gained heat and expanded faster than the outer surface

2  
EAD