



**NAN HUA PRIMARY SCHOOL  
END-OF-YEAR EXAMINATION 2022  
PRIMARY 5**

**SCIENCE**

**BOOKLET A**

**28 Multiple Choice Questions (56 marks)**

**Total Time for Booklets A and B : 1 hour 45 minutes**

**INSTRUCTIONS TO CANDIDATES**

1. Write your name and index number in the space provided.
2. Do not turn over the page until you are told to do so.
3. Follow all instructions carefully.
4. Answer all questions.
5. Shade your answers in the Optical Answer Sheet (OAS) provided.

**Marks Obtained**

<b>Booklet A</b>		<b>/ 56</b>
<b>Booklet B</b>		<b>/ 44</b>
<b>Total</b>		<b>/ 100</b>

Name \_\_\_\_\_ (      )

Class: P 5S \_\_\_\_\_

Date: 27 October 2022

Parent's Signature: \_\_\_\_\_

**Section A: (28 × 2 marks = 56 marks)**

For each question from 1 to 28, four options are given. One of them is the correct answer. Make your choice (1, 2, 3 or 4) and shade your answer on the Optical Answer Sheet.

- 1 The diagram below shows part X of a plant.

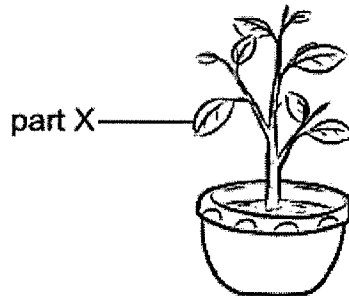

What is/are the function(s) of part X?

- A taking in air
  - B making food
  - C taking in water
- 
- (1) B only
  - (2) A and B only
  - (3) A and C only
  - (4) B and C only

(Go on to the next page)

2 The diagram below represents the transport system of a plant.

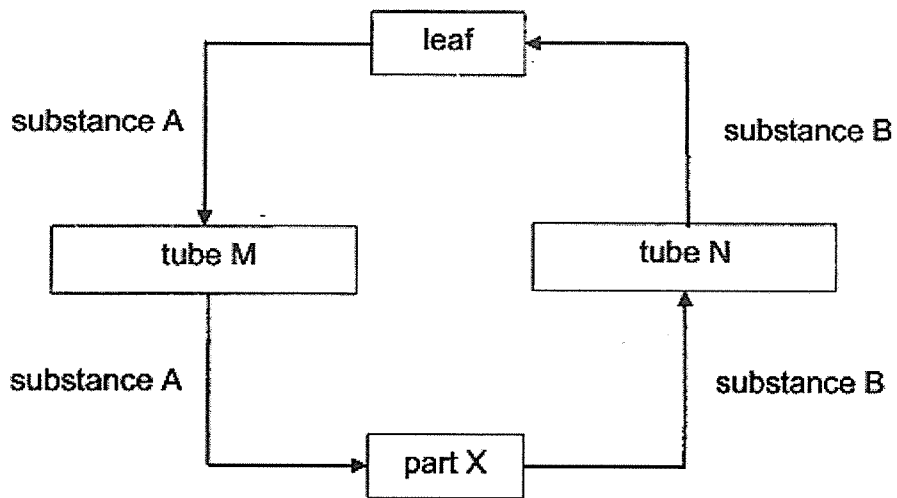

Which of the following correctly identifies part X and substances A and B?

	<b>part X</b>	<b>substance A</b>	<b>substance B</b>
(1)	stem	water	food
(2)	leaf	food	water
(3)	root	water	food
(4)	root	food	water

3 At which organ of the digestive system is water from the undigested food being absorbed?

- (1) gullet
- (2) mouth
- (3) stomach
- (4) large intestine

(Go on to the next page)

- 4 The diagram below shows how three body systems work together. The arrows show the movement of some important substances in the body.

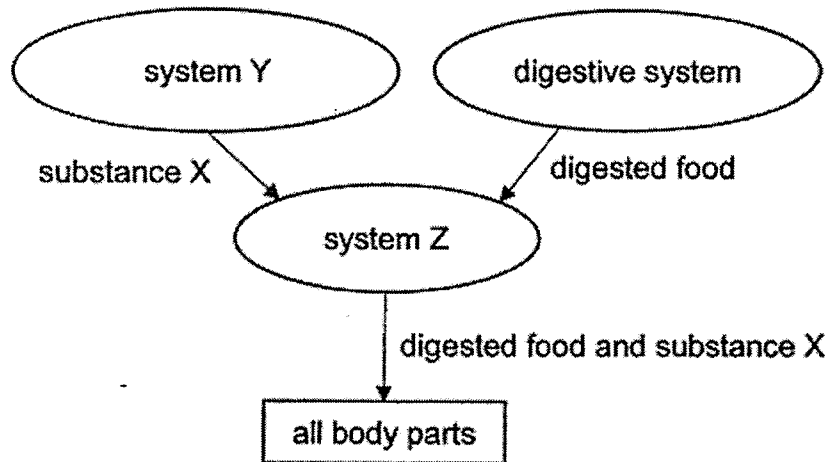

Which of the following correctly matches substance X and body systems Y and Z?

	substance X	system Y	system Z
(1)	oxygen	circulatory	respiratory
(2)	oxygen	respiratory	circulatory
(3)	carbon dioxide	circulatory	respiratory
(4)	carbon dioxide	respiratory	circulatory

- 5 Which of the following comparisons between the plant transport system and the human transport system is correct?

	Plant Transport System	Human Transport System
(1)	Blood in the tubes transport the substances	Water in the blood vessels transport the substances
(2)	Has one network of tubes to transport the substances	Has two network of tubes to transport the substances
(3)	Transports food produced in the leaves	Transports only undigested food to all parts of the body
(4)	Does not have an organ to pump the substances to all other parts	Has an organ to pump the substances to all other parts

(Go on to the next page)

- 6 Ben was trapped in a lift with a group of people when it stopped working for 45 minutes. The fan in the lift was not working and the lift door was tightly shut.

Which of the following is the most likely changes to the amount of oxygen, carbon dioxide, nitrogen and water vapour in the lift after 45 minutes?

(1)

Gas	Change
Oxygen	Decrease
Carbon dioxide	Increase
Nitrogen	No change
Water vapour	No change

(2)

Gas	Change
Oxygen	Decrease
Carbon dioxide	Increase
Nitrogen	No change
Water vapour	Increase

(3)

Gas	Change
Oxygen	Increase
Carbon dioxide	Decrease
Nitrogen	No change
Water vapour	Decrease

(4)

Gas	Change
Oxygen	Decrease
Carbon dioxide	Increase
Nitrogen	Increase
Water vapour	No change

- 7 The diagram below shows a human heart that receives blood and pumps it to different parts of the body.

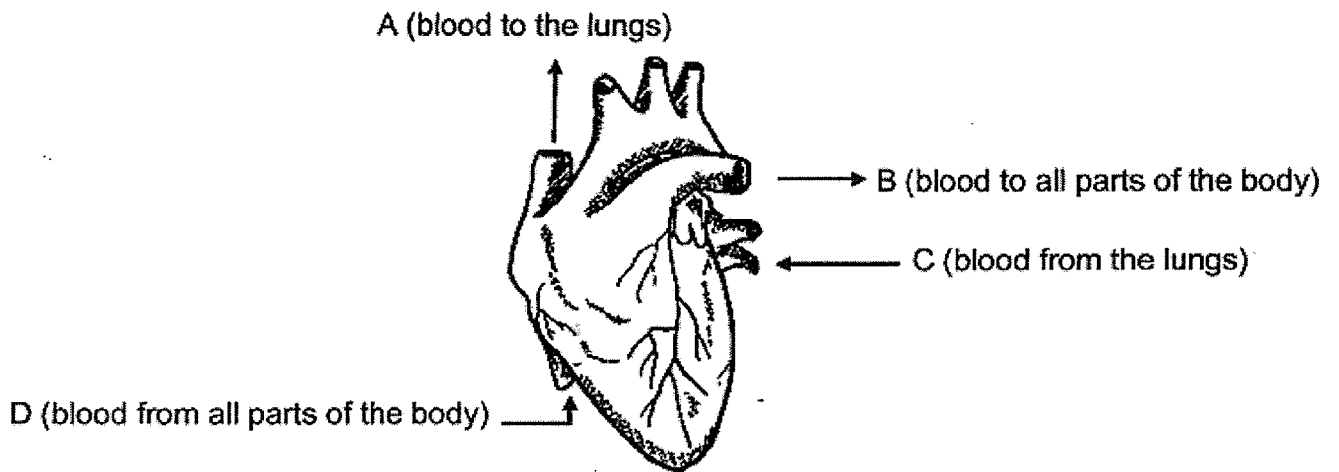

Which of the following graphs shows the amount of carbon dioxide in the different blood vessels, A, B, C and D?

(1)

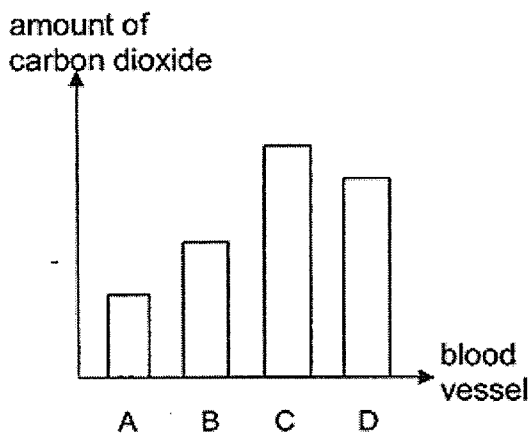

(2)

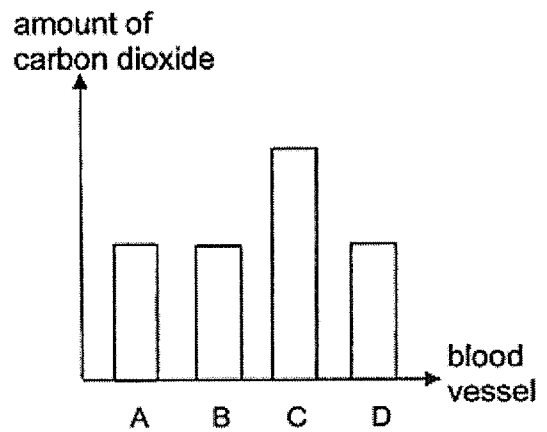

(3)

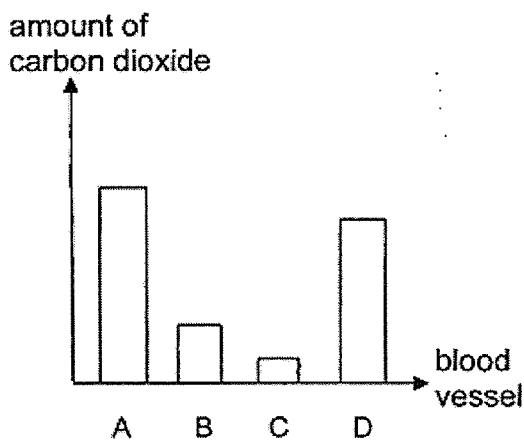

(4)

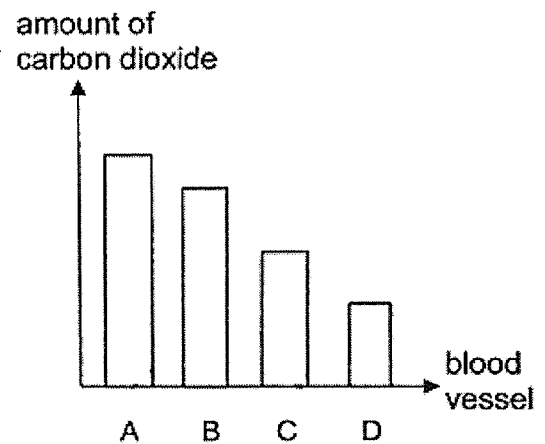

- 8 Alex examines the animal cell as shown below and writes some statements.

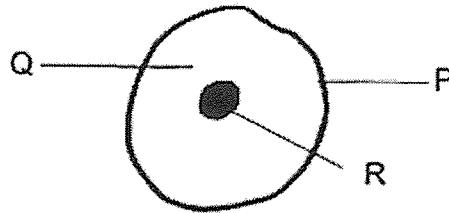

- A Q is a jelly-like substance.  
 B R controls the activities within the cell.  
 C P is a cell wall which gives the cell a regular shape.

Which of the statements written by Alex are correct?

- (1) A and B only  
 (2) A and C only  
 (3) B and C only  
 (4) A, B and C
- 9 Belle was asked to identify three cells, A, B and C.

Parts of a cell	Name of cell		
	Cell A	Cell B	Cell C
nucleus	present	present	present
cell wall	present	absent	present
cytoplasm	present	present	present
chloroplasts	present	absent	absent
cell membrane	present	present	present

Based on the information in the table above, what could cells, A, B and C be?

- (1) 

Cell A	Cell B	Cell C
cheek cell	leaf cell	root cell
- (2) 

Cell A	Cell B	Cell C
leaf cell	cheek cell	root cell
- (3) 

Cell A	Cell B	Cell C
root cell	cheek cell	leaf cell
- (4) 

Cell A	Cell B	Cell C
leaf cell	root cell	cheek cell

(Go on to the next page)

10 The diagram below shows the development of a germinating seed.

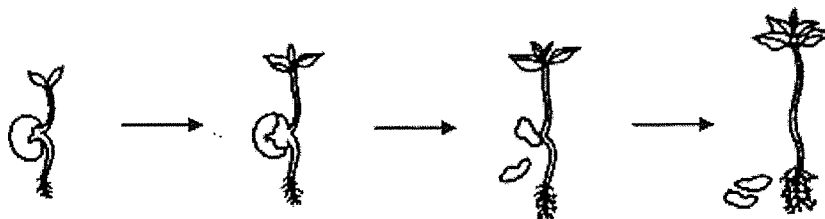

Which of the following graphs correctly shows the relationship between the mass of the seed leaves and the height of seedling?

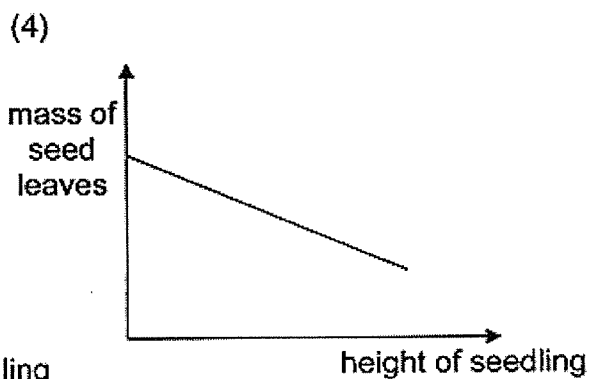
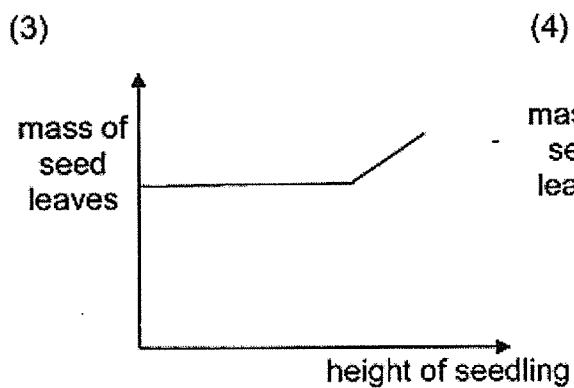
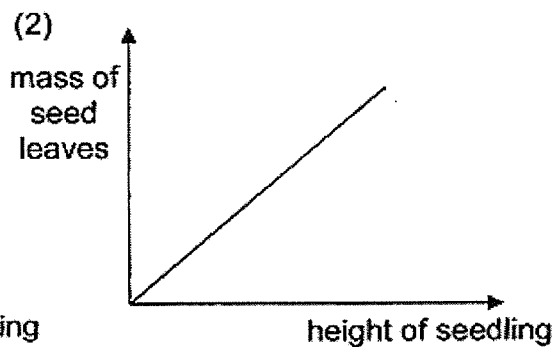
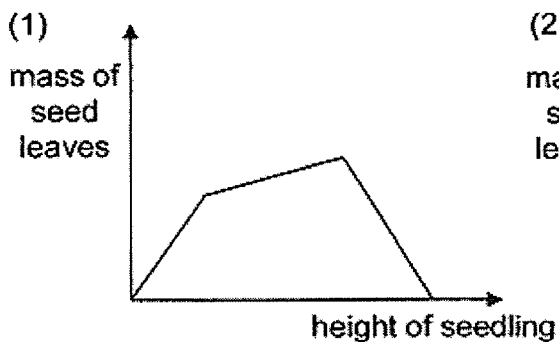

(Go on to the next page)



- 11 The table below shows what a pupil had observed about the growth of insect X.

Date	Observation
6 August	Many eggs were laid.
10 August	Most eggs hatched into larvae.
18 August	Some larvae became pupae.
29 August	Some pupae became adult insects.

Based only on the information in the table above, which statement about insect X is correct?

- (1) All the eggs hatched into larvae.
  - (2) The larva stage comes right after the pupa stage.
  - (3) It took six days for the larvae of insect X to hatch from the eggs.
  - (4) Insect X spends most of its life as a pupa before becoming an adult.
- 12 The characteristics that can be passed from parents to their offspring are \_\_\_\_\_.
- P fingerprint
  - Q length of hair
  - R curved thumb
  - S type of eyelid
- (1) P and R only
  - (2) Q and S only
  - (3) R and S only
  - (4) P, R and S only

(Go on to the next page)

13 Sammy drew the reproductive parts of a human and a plant respectively.

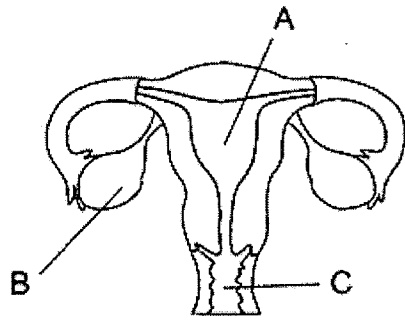

human reproductive system

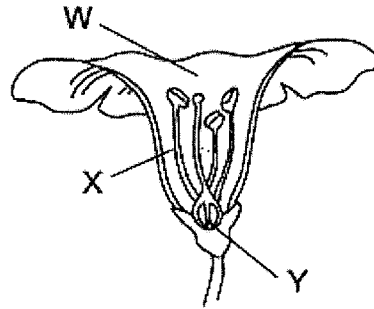

plant reproductive system

Which two parts indicate where the development of a fertilised egg take place in the human reproductive system and the plant reproductive system?

- (1) A and X
- (2) A and Y
- (3) B and Y
- (4) C and W

(Go on to the next page)

- 14 Study the diagrams below. The set-ups, P, Q, R and S, are placed on the table in the science laboratory.

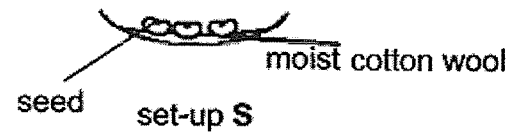
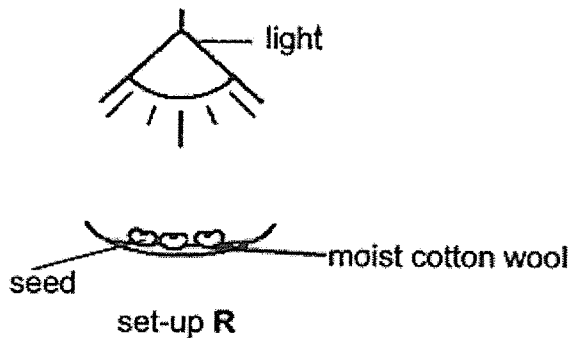
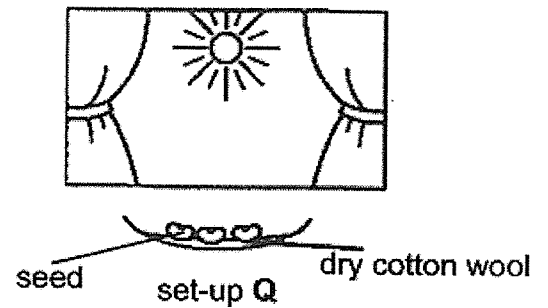
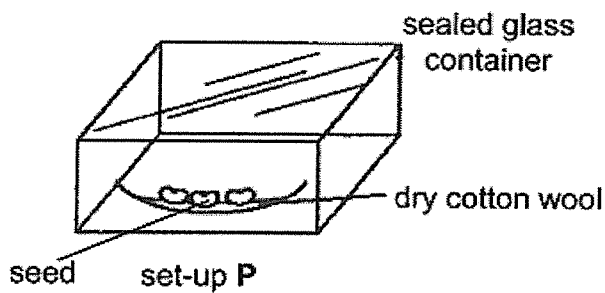

In which of the set-ups above will the seeds be able to germinate?

- (1) P and Q only
  - (2) Q and R only
  - (3) R and S only
  - (4) Q, R and S only
- 15 For an adult plant to produce seeds, which of the following process(es) must take place?
- (1) germination only
  - (2) cross-pollination only
  - (3) pollination and fertilization
  - (4) germination and pollination

(Go on to the next page)

- 16 The diagram below shows the plastic bags used to fit wet umbrellas to keep the floor in the shopping malls dry on rainy days.

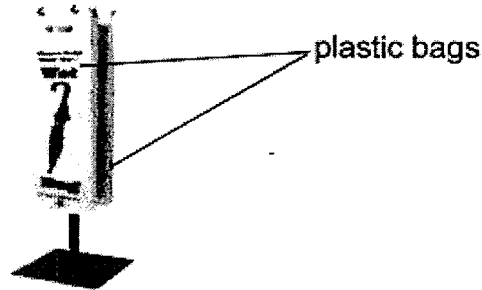

Which two properties must these plastic bags have to serve the purpose?

- (1) strong and stiff
  - (2) light and transparent
  - (3) waterproof and flexible
  - (4) waterproof and transparent
- 17 Jess wanted to know if an object X has magnetic properties. She carried out some tests and wrote her observations of object X as shown below.

**Object X:**

- is attracted to a magnet
- comes to rest in an east-west direction when hung freely

What could object X be?

- (1) iron bar
- (2) glass rod
- (3) bar magnet
- (4) wooden block

(Go on to the next page)

- 18 Mingwei completely filled up three similar syringes, each with a different substance of either air, cotton wool or water. The opening of each syringe was sealed and the plunger was at the 10 cm mark at first.

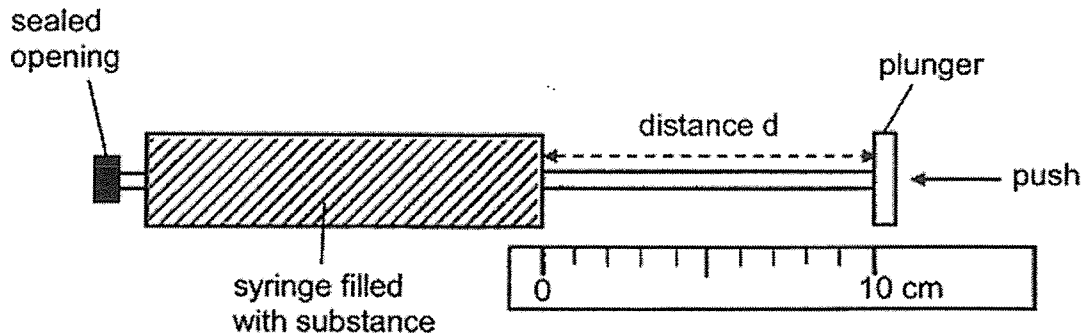

Mingwei pushed the plunger of each of the syringes inwards with an equal amount of force.

Which of the following was likely the distance  $d$ , recorded for each syringe after the push?

	Distance $d$ for syringe filled with air (cm)	Distance $d$ for syringe filled with cotton wool (cm)	Distance $d$ for syringe filled with water (cm)
(1)	5	7	5
(2)	5	7	10
(3)	10	5	7
(4)	7	10	10

- 19 Kate poured some cold water into a beaker. After five minutes, she observed some water droplets forming on the beaker as shown below.

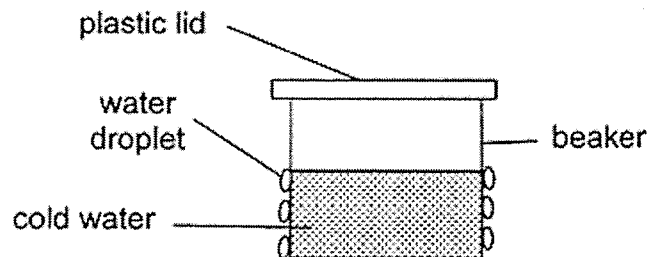

Which of the following process resulted in the formation of the water droplets?

- (1) boiling
- (2) melting
- (3) evaporation
- (4) condensation

(Go on to the next page)

20 Which of the following diagrams does **not** show the effect of heat gain correctly?

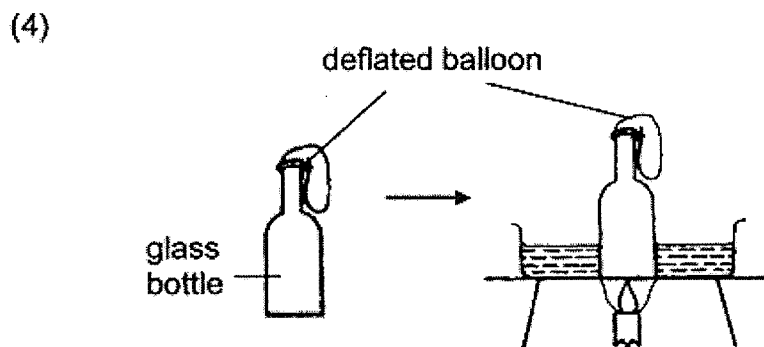
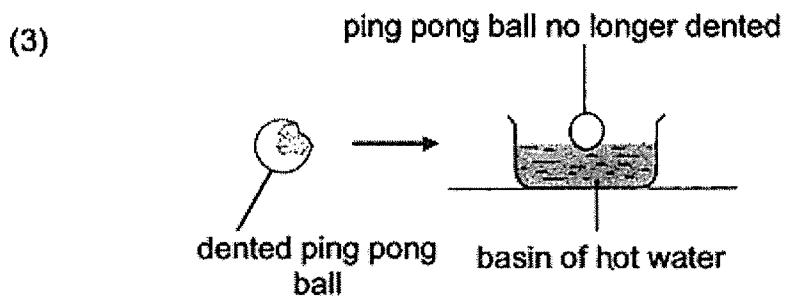
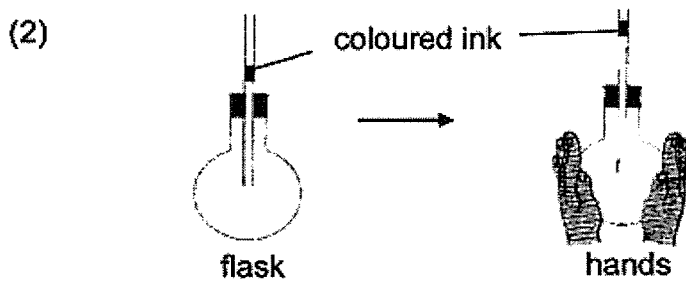
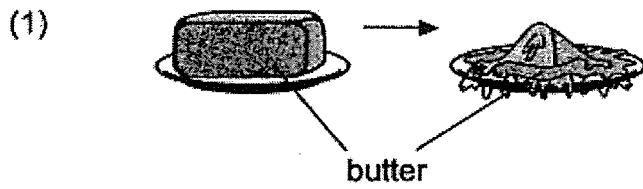

- 21 A beaker of ice cubes was left on a table to melt. After melting, the water later reached room temperature. The water was then heated over a flame until it boiled. The following graph was plotted to show the changes in temperature over the period of time.

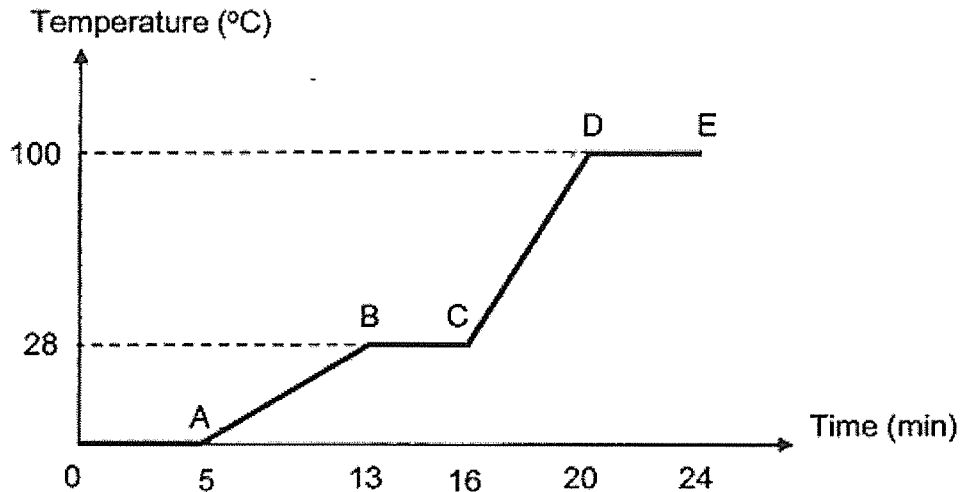

Based on the graph, which of the following statements is not correct?

- (1) The room temperature was 28 °C.
  - (2) All ice cubes had melted after 5 minutes.
  - (3) Heat from a flame was supplied at point B.
  - (4) There was a change of state at points D to E in the experiment.
- 22 Water changes from one state to another as shown in the diagram below.

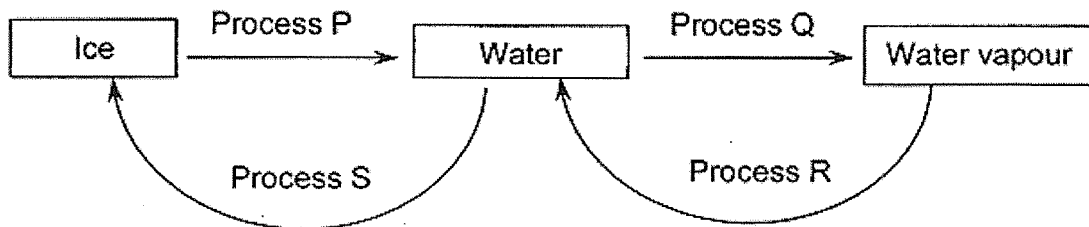

Which of the following statements are correct?

- A Process S is condensation.
  - B Process Q can only happen at 100 °C.
  - C Process Q involves heat gain by the water.
  - D Water vapour loses heat during process R.
- (1) A and B only
  - (2) C and D only
  - (3) B, C and D only
  - (4) A, B, C and D

- 23 Thiru prepared a set-up to investigate the effect of heat on the volume of air in the flask as shown below.

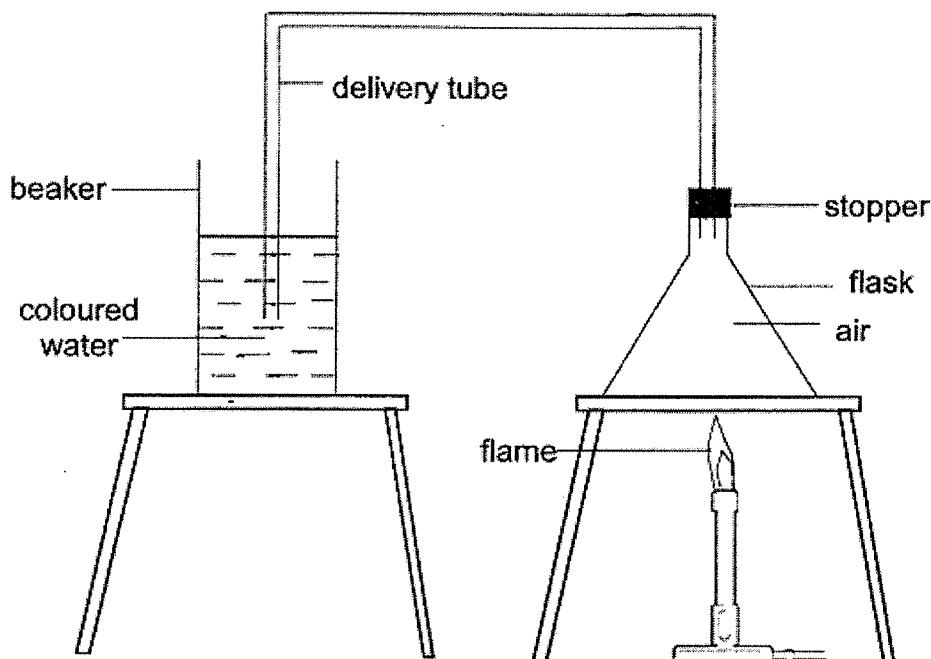

Which of the following correctly describes the observation of the experiment and the explanation for the observation?

	Observation	Explanation
(1)	Coloured water from the beaker was drawn into the flask through the delivery tube.	Air in the flask lost heat and contracted. This created a space for the coloured water to move towards the flask.
(2)	Coloured water from the beaker was drawn into the flask through the delivery tube.	Air in the flask gained heat and expanded. This created a space for the coloured water to move towards the flask.
(3)	Air bubbles are observed leaving the coloured water after passing through the delivery tube.	Air in the flask gained heat and expanded. Some of the warm air was pushed through the delivery tube and escaped as bubbles in the coloured water.
(4)	Air bubbles are observed leaving the coloured water after passing through the delivery tube.	Air in the flask lost heat and contracted. Some of the cool air was pushed through the delivery tube and escaped as bubbles in the coloured water.



- 24 Hailey cut out a square shape from a wooden block and a circular shape from a clear glass block as shown below.

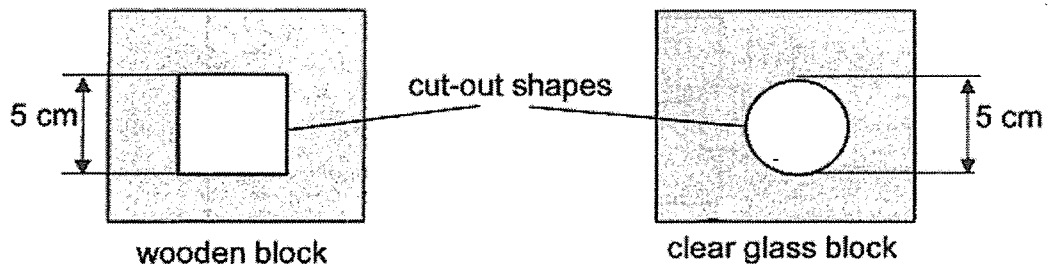

She then glued the two blocks together. A lamp with red light was brought near the two blocks as shown in the diagram below.

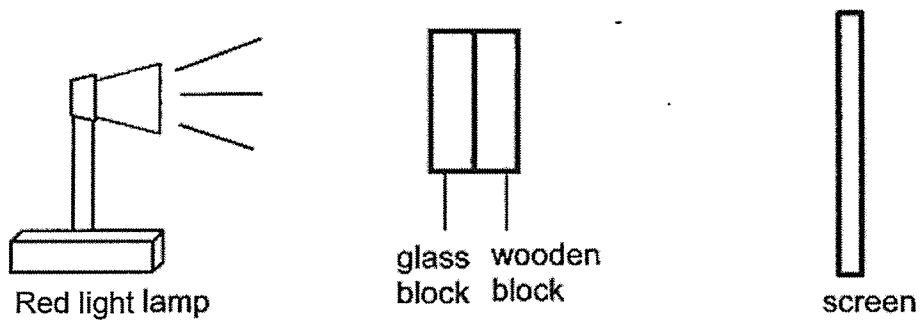

Which one of the following was most likely to be the shadow formed on the screen?

- (1) (2)
- (3) (4)

- 25 The diagram below shows the different components that make up an electric circuit.

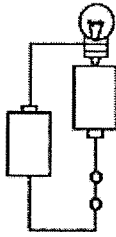

Which of the following components is the energy source for the circuit?

- (1) bulb
  - (2) wire
  - (3) switch
  - (4) battery
- 26 The diagram below shows an electrical system made up of three switches, two light bulbs and three batteries.

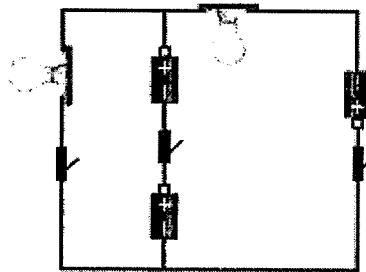

Which of the following circuit diagrams shows the correct representation of the actual system shown above?

- (1)
- (2)
- (3)
- (4)

- 27 Four students set up an electrical circuit with four identical bulbs, B1, B2, B3 and B4. They recorded the number of bulbs that lit up after varying the positions of the bulbs. Their observations were as shown below.

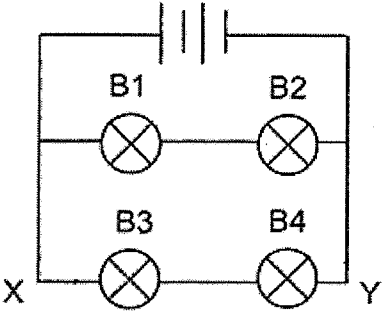
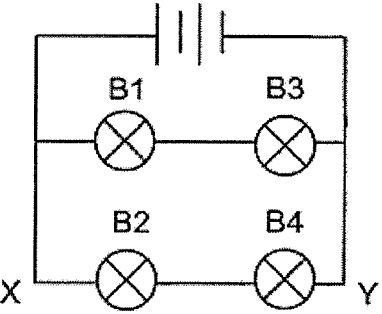
First arrangement	Observations
	<ul style="list-style-type: none"> <li>• Only bulbs B1 and B2 lit up</li> </ul>
Second arrangement	Observations
	<ul style="list-style-type: none"> <li>• None of the bulbs lit up</li> </ul>

Which of the following was a possible reason to explain why some bulbs did not light up based on the observations above?

- (1) Bulb B3 was the only faulty bulb.
- (2) Bulb B4 was the only faulty bulb.
- (3) Wires along X to Y had disconnected.
- (4) Bulbs B3 and B4 were the only faulty bulbs.

- 28 Three electrical circuits, X, Y and Z, are set up as shown below. Each circuit consists of a battery, a bulb and three rods made of different materials, namely iron, wood and plastic.

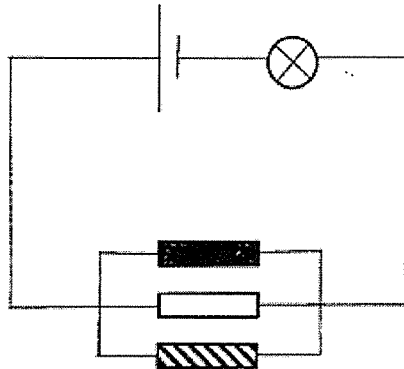

circuit X

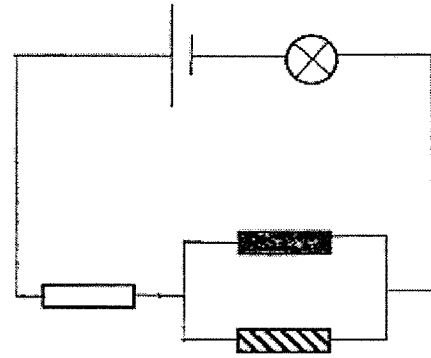

circuit Y

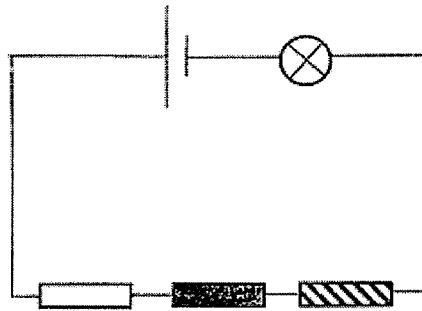

circuit Z

In which of the above circuit(s) would the bulb light up?

- (1) Circuit X only
- (2) Circuits X and Y only
- (3) Circuits Y and Z only
- (4) None of the circuits above



**NAN HUA PRIMARY SCHOOL  
END-OF-YEAR EXAMINATION 2022  
PRIMARY 5**

**SCIENCE**

**BOOKLET B**

**13 Open-ended questions (44 marks)**

**Total Time for Booklets A and B: 1 hour 45 minutes**

**INSTRUCTIONS TO CANDIDATES**

1. Write your name and index number in the space provided.
2. Do not turn over the page until you are told to do so.
3. Follow all instructions carefully.
4. Answer all questions.
5. Write your answers in this booklet.

**Marks Obtained**

<b>Section B</b>		<b>/ 44</b>
------------------	--	-------------

**Name:** \_\_\_\_\_ (      )

**Class:** P 5S \_\_\_\_\_

**Date:** 27 October 2022

**Parent's Signature:** \_\_\_\_\_

---

This booklet consists of 16 pages.

**Section B: (44 marks)**

Write your answers to question 29 to 41 in the space provided.

The number of marks available is shown in brackets [ ] at the end of each question or part question.

29 The diagram below shows a cross-section of a plant transport system.

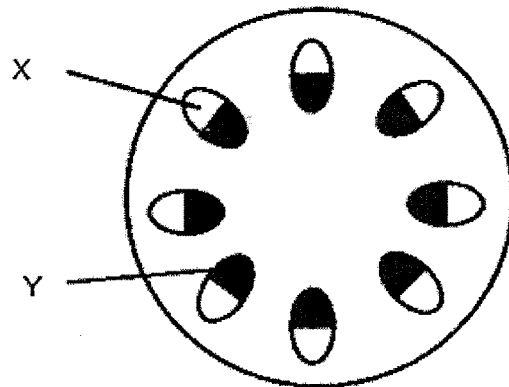

(a) Name the parts, X and Y, as shown in the diagram above.

X: \_\_\_\_\_ [1]

Y: \_\_\_\_\_ [1]

(b) What would happen to the plant after a month if all of part X are damaged? Explain your answer. [1]

\_\_\_\_\_

(c) What is the function of part Y? [1]

\_\_\_\_\_

(Go on to the next page)

Score	4
-------	---

30 The diagrams below show the respiratory systems of a fish and a human.

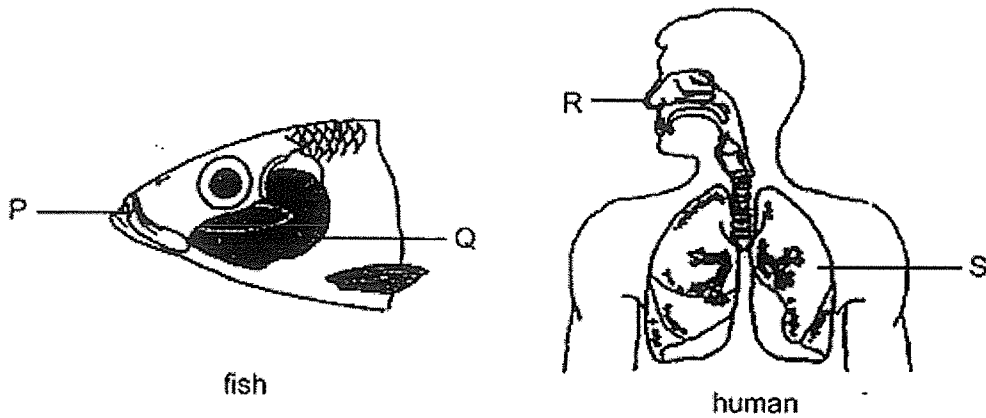

(a) At which positions, P, Q, R or S, do gaseous exchange take place in a fish and a human? [1]

Fish : \_\_\_\_\_

Human : \_\_\_\_\_

(b) Explain why the blood needs to be transported back to the lungs in the human respiratory system. [1]

---

---

---

---

(c) Describe clearly how the fish gets oxygen for its survival. [2]

---

---

---

---

(Go on to the next page)

Score	4
-------	---

31 Study the flow chart below carefully.

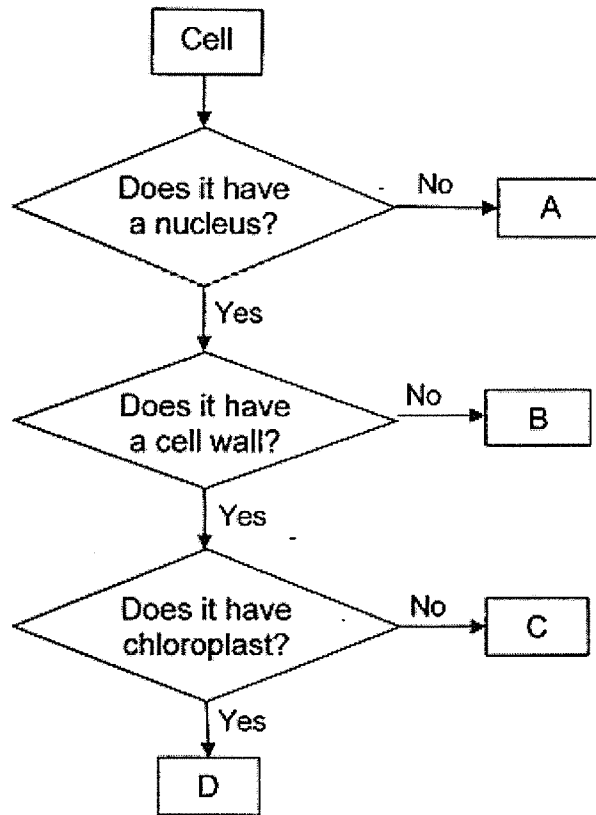

(a) Based on the flow chart, put a tick in the correct box for the type of cell as indicated in the flow chart. [2]

Type of Cell	A	B	C	D
Cheek cell				
Leaf cell				

(b) Based on the flow chart, which type of cell, A, B, C or D, is taken from the root of a plant? Explain your answer. [1]

---



---

(c) Based on the flow chart, state one difference between cell A and cell B. [1]

---



---

(Go on to the next page)

Score	4
-------	---



32 The flow chart below shows the human reproductive system.

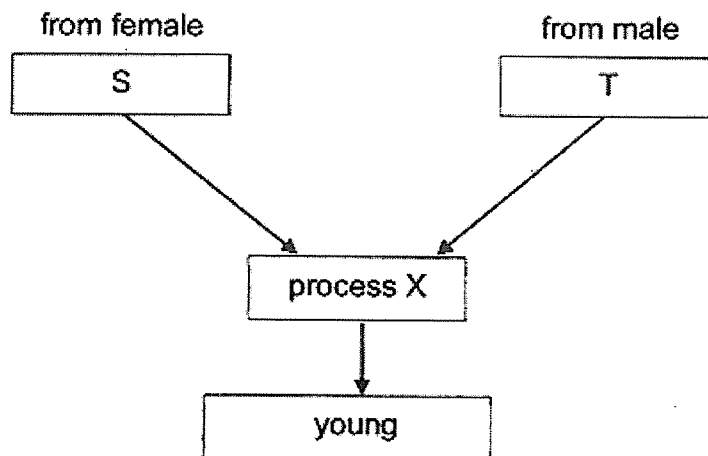

(a) Based on the flow chart above, name the reproductive cells that both the letters, S and T, represent. [1]

S: \_\_\_\_\_

T: \_\_\_\_\_

(b) What is process X? Describe what happens during the process. [1]

---

---

---

(c) Where does the young develop in the human reproductive system? [1]

---

---

(Go on to the next page)

Score	3
-------	---

33 Susan records the characteristics of fruits W, X and Y in the table below.

Description of fruit	Characteristics of fruit W	Characteristics of fruit X	Characteristics of fruit Y
Is edible	yes	yes	no
Has fibrous husk	no	yes	no
Is juicy and fleshy	yes	no	no
Is bright red only when ripe	yes	no	no
Has wing-like structure	no	no	yes

(a) What is the likely method of seed dispersal for fruit W? [1]

---

(b) Describe how being juicy and fleshy help the seeds to be dispersed further away from the parent plant. [1]

---

---

Diagram 1 below shows the seed dispersal pattern of one of the fruits.

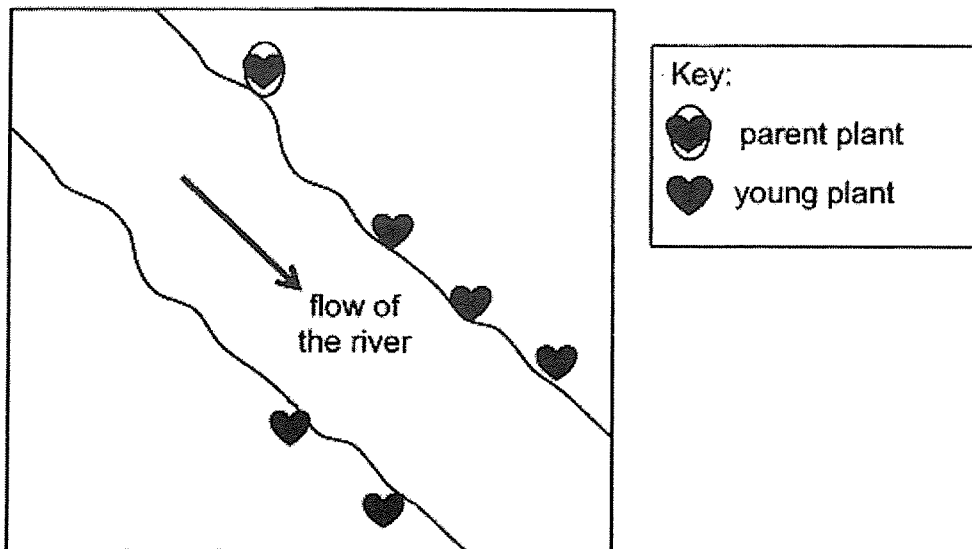

Diagram 1

- (c) Based on diagram 1, what is the likely method of seed dispersal of the fruit shown above? Give a reason for your answer. [1]

---

---

---

- (d) Based on the information from the diagram 1 and the earlier table, which fruit, X or Y, has the seed dispersal pattern shown above? Explain your answer. [1]

---

---

---

(Go on to the next page)

Score	4
-------	---

34 The diagram below shows the cross-section of flower H.

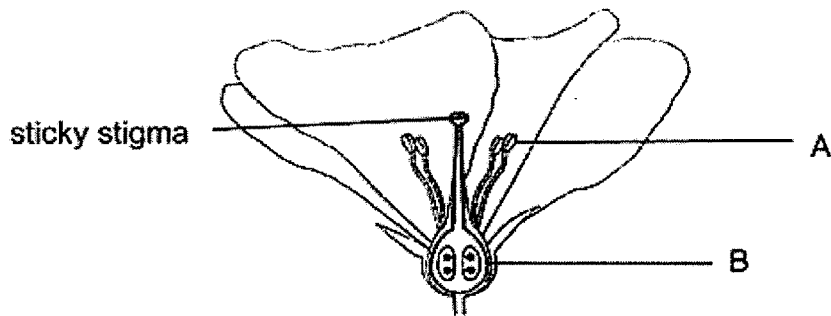

(a) What is the function of A in a plant? [1]

---

(b) What is the advantage of having a sticky stigma in the process of pollination? [1]

---

---

(c) How would the removal of part B affect flower H? Explain your answer. [1]

---

---

(Go on to the next page)

Score	3
-------	---

- 35 Cindy wanted to find out if the strength of an electromagnet is affected by the number of coils of wire around an iron rod. She conducted an experiment using four set-ups, A, B, C and D.

The experimental conditions and results are as shown below.

Set-up	A	B	C	D
Number of batteries	3	2	2	3
Number of coils of wire around iron rod	30	40	10	40
Number of paper clips attracted	10	10	5	16

- (a) Which two set-ups should Cindy compare for her experiment? [1]

---

- (b) Comparing set-ups B and D, what is the relationship between the number of batteries used and the strength of an electromagnet? [1]

---



---

- (c) Electromagnets are commonly used in sorting out magnetic waste from non-magnetic materials. One such example is as shown below.

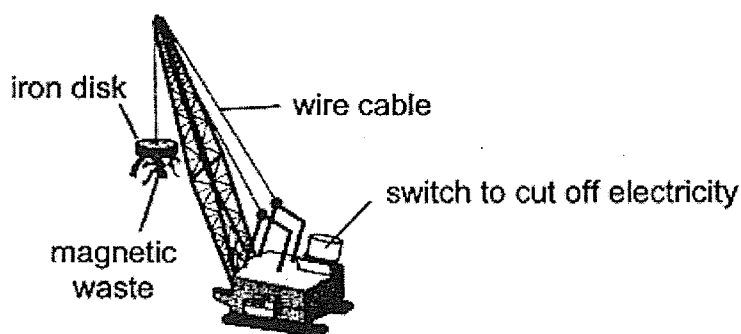

Why is an electromagnet used instead of a normal powerful magnet in sorting out magnetic waste? [1]

---



---

(Go on to the next page)

Score	3
-------	---

- 36 Macy carried out an experiment by placing a test tube of tap water at 28 °C into a beaker of ice cubes.

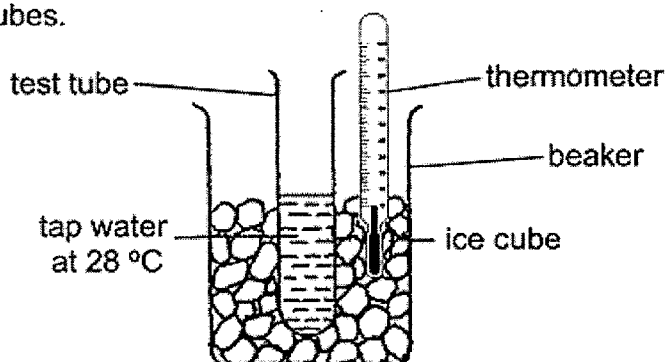

She then plotted a graph showing the change in temperature of the beaker of ice cubes over time as shown below.

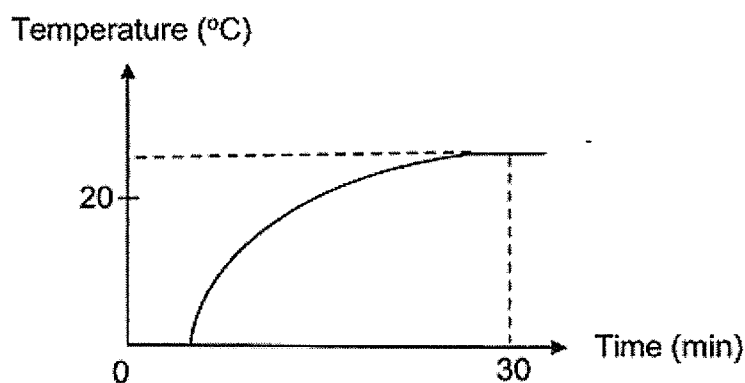

- (a) Explain why the tap water became cooler when placed into the beaker of ice cubes. [1]
- 
- 
- (b) Based on the information above, state a possible room temperature where Macy carried out her experiment. [1]
- 
- 
- (c) Macy's teacher suggested that she should use crushed ice instead of ice cubes to cool the tap water more quickly. Explain how her teacher's suggestion works. [1]
- 
- 

(Go on to the next page)

Score	3
-------	---

- 37 Shi Chen carried out an experiment using set-up A and set-up B as shown below. The fan in set-up A was switched on during the experiment but the fan in set-up B was not.

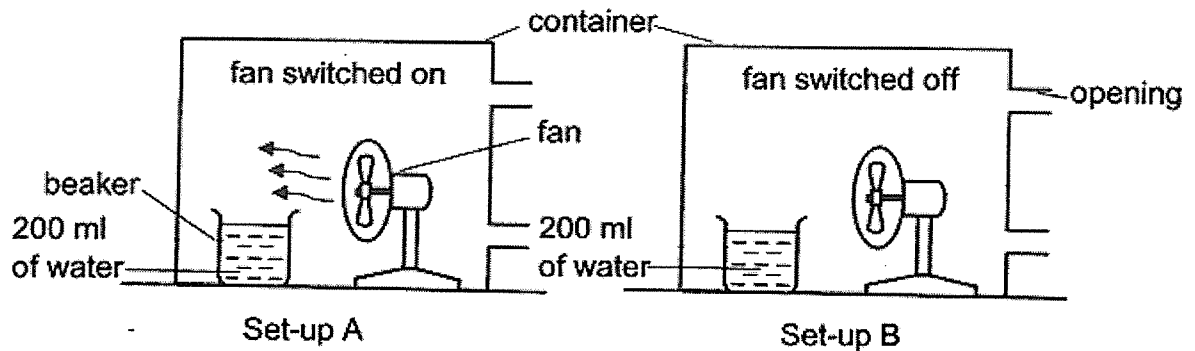

After three hours, she recorded the amount of water left in each beaker.

- (a) In which set-up, A or B, would **less** water be left in the beaker? Explain your answer. [2]

---

---

---

- (b) State the aim of Shi Chen's experiment. [1]

---

---

- (c) What was the purpose of the container in the experiment? [1]

---

---

(Go on to the next page)

Score	
	4

- 38 Kavi wanted to find out which material was most suitable to keep his coffee warm for the longest period of time. He placed three cups, A, B and C, of different materials, containing the same amount of coffee of the same temperature (35 °C) on a hot plate.

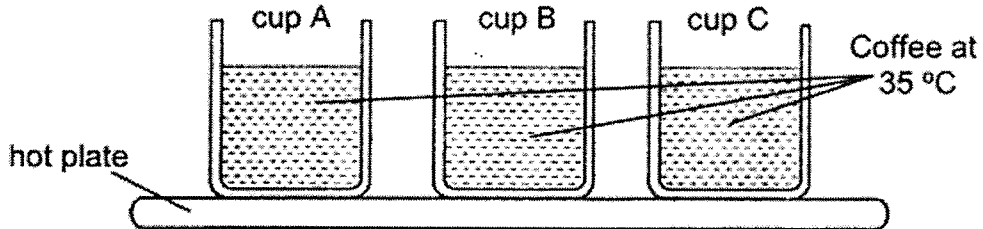

He measured the temperature of the coffee in each cup after five minutes and recorded the results in the table below.

Temperature of coffee (°C) after 5 minutes		
Cup A	Cup B	Cup C
40	60	50

- (a) Arrange the three cups, A, B and C, according to their ability to conduct heat beginning with the best to the poorest conductor of heat. [1]

---

---

- (b) Should Kavi use cup B to keep his hot coffee warm for the longest period of time? Explain your answer. [2]

---

---

(Go on to the next page)

Score	3
-------	---



- 39 Gordon set up an experiment using a torch and a cylinder to cast a dark shadow on a screen as shown in the diagram below.

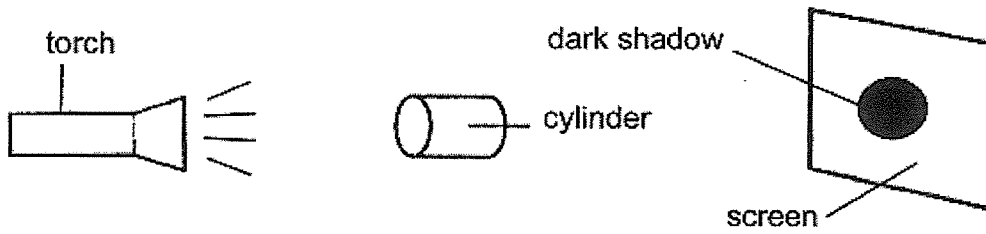

- (a) Without adding or removing any items in the set-up above, what could Gordon do to get a bigger shadow? [1]

---

---

- (b) Based on the diagram above, describe the transparency of the cylinder. [1]

---

Gordon made some changes to his original set-up. He changed the position of the torch and screen as shown.

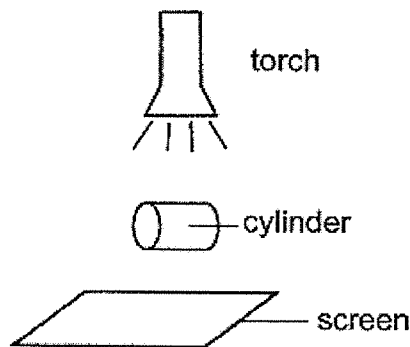

- (c) In the box below, draw the shadow that Gordon would observe on the screen. [1]

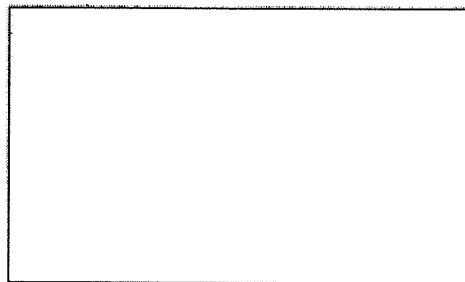

(Go on to the next page)

Score	/
	3

40 Arif has a toy tank which works on batteries.

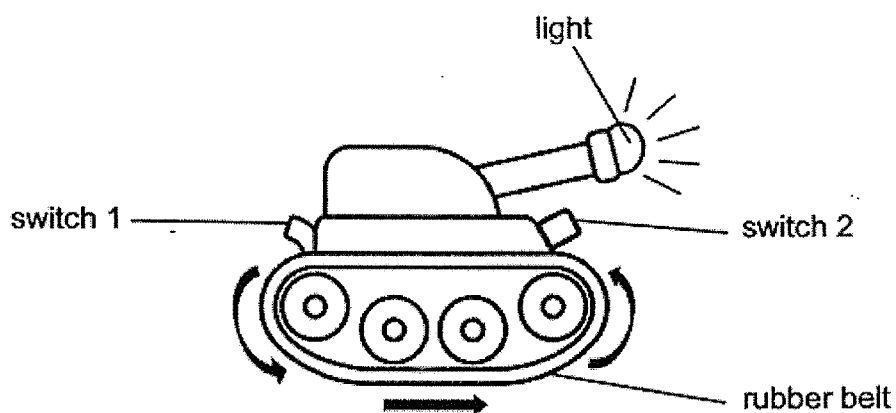

He plays with the toy tank and records his observations below.

Switch(es) turned on	Observations
Switch 1 only	Rubber belt moves
Switch 2 only	Light lit up
Switches 1 and 2	Light lit up and rubber belt moves

(a) Based on the information above, complete the electric circuit below to show how Arif's toy tank could have been connected. [2]

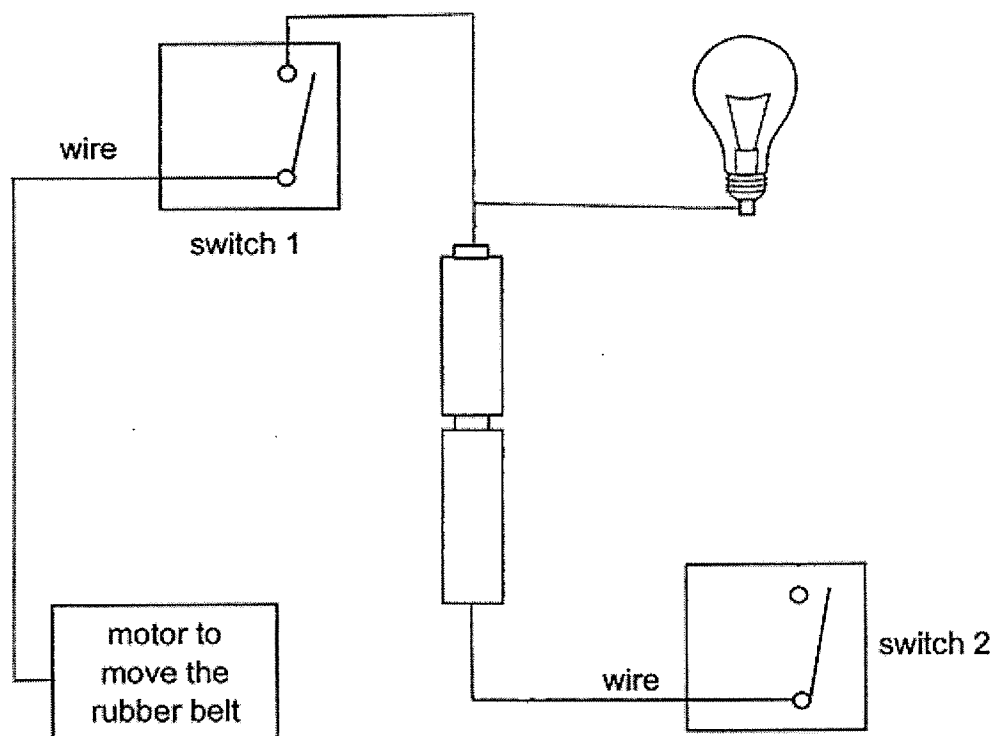

(Go on to the next page)

- (b) If the light bulb in the toy tank fuses, will the rubber belt still be able to move?  
Explain your answer. [1]

---

---

(Go on to the next page)

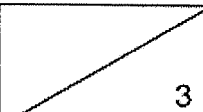
Score	
-------	---

- 41 Study the three electrical circuits, A, B and C, below. All the bulbs and batteries used are identical and are in good working condition.

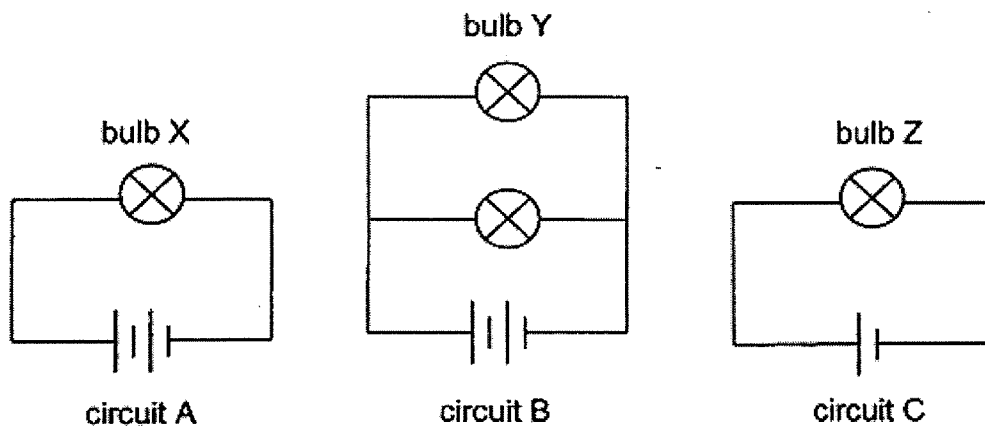

- (a) Write down 'True' or 'False' beside each statement in the given boxes below. [2]

Statement	True or False
(i) Bulb Z is the dimmest among all the bulbs.	
(ii) Bulb X is brighter than bulb Y.	

- (b) If one more bulb is added in series to circuit C, how will the brightness of bulb Z be affected? [1]

---



---

~ End of Paper ~

Score	3
-------	---

SCHOOL : NAN HUA PRIMARY SCHOOL  
 LEVEL : PRIMARY 5  
 SUBJECT : SCIENCE  
 TERM : 2022 SA2

**SECTION A**

Q 1	Q2	Q3	Q4	Q5	Q6	Q7	Q8	Q9	Q10
2	4	4	2	4	2	3	1	2	4
Q 11	Q12	Q13	Q14	Q15	Q16	Q17	Q18	Q19	Q20
4	3	2	3	3	3	1	2	4	4
Q 21	Q22	Q23	Q24	Q25	Q26	Q27	Q28		
3	2	3	4	4	1	4	1		

**SECTION B**

Q29)	<p>a) X: food-carrying tube Y: water-carrying tube</p> <p>b) The plant will die as it has no food-carrying tube(s) to transport food from the leaves to other / all parts of the plant.</p> <p>c) The water-carrying tube(s) transports water and mineral salts / minerals / nutrients from the root to other / all parts of the plant.</p>
Q30)	<p>a) Fish: Q Human: S</p> <p>b) The blood will absorb / take in oxygen from the lungs and remove / release carbon dioxide at / into the lungs.</p> <p>OR</p> <p>At the lungs, the blood absorbs oxygen and release carbon dioxide.</p> <p>OR</p> <p>At the lungs, the blood exchange carbon dioxide for oxygen.</p> <p>c) Water containing (dissolved) oxygen will enter the mouth and pass through the gills / gill filament where the (dissolved) oxygen will be absorbed into the bloodstream.</p>

	<p>OR</p> <p>Water will enter the mouth. Dissolved oxygen in water will be absorbed into the blood at the gills.</p>															
Q31)	<p>a)</p> <table border="1"> <thead> <tr> <th>Type of cell</th> <th>A</th> <th>B</th> <th>C</th> <th>D</th> </tr> </thead> <tbody> <tr> <td>Check cell</td> <td></td> <td>√</td> <td></td> <td></td> </tr> <tr> <td>Leaf cell</td> <td></td> <td></td> <td></td> <td>√</td> </tr> </tbody> </table> <p>b) Cell C. It does not contain / have chloroplast(s) to trap sunlight / light to make food.</p> <p>c) Cell B has a nucleus but Cell A does not.</p>	Type of cell	A	B	C	D	Check cell		√			Leaf cell				√
Type of cell	A	B	C	D												
Check cell		√														
Leaf cell				√												
Q32)	<p>a) S: egg cell / egg T: sperm</p> <p>b) Fertilisation. During fertilisation, the male's sperm / reproductive cell fuses with / fertilises the female's egg / egg cell.</p> <p>c) The young develops in the womb of the female's body / mother.</p>															
Q33)	<p>a) Seed W is dispersed by animals.</p> <p>b) Being juicy and fleshy will attract the animals to eat the fruit. The (big) undigested seeds will either be thrown away / pass out in droppings after some distance.</p> <p>c) By water. The young plants are growing along the river.</p> <p>d) Fruit X. Fruit X has a fibrous husk which has air space / which traps air. The air space helps it to float in water. The seeds will germinate along the river.</p>															
Q34)	<p>a) Part A produces for stores pollen grains.</p> <p>b) The stigma can trap and hold the pollen grains dispersed (by the animals).</p> <p>c) Fertilisation will not take place and the ovary / flower will not develop into a fruit.</p> <p>OR</p> <p>Flower X cannot reproduce as the ovary / flower cannot develop into a fruit.</p>															
Q35)	<p>a) A and D OR B and C</p>															

	<p>b) As the number of batteries used increased / decreased and the strength of an electromagnet increased / decreased.</p> <p>c) An electromagnet can lose its magnetism easier / faster by opening a switch / cutting off the electricity supply to release the attracted magnetic waste for complete separation.</p> <p>OR</p> <p>An normal magnet cannot lose its magnetism easier / faster to release the attracted magnetic waste for complete separation.</p>
Q36)	<p>a) The tap water loses heat to the beaker of ice cubes.</p> <p>b) Accept more than 20°C and less than or equal to 28°C i.e 21°C , 22°C , 23°C , 24°C , 25°C , 26°C , 27°C , 28°C</p> <p>c) Crushed ice has a greater / increased exposed surface area in contact with (the test tube of) the tap water to allow faster / more heat lost by the tap water to the ice.</p>
Q37)	<p>a) C: Set-up A</p> <p>E: Only the fan in set-up A was switched on.</p> <p>C: More wind / greater air movements is present in set-up A to increase the rate of evaporation of water.</p> <p>L: Hence, less water will be observed in the beaker of set-up A.</p> <p>b) To find out if the presence / amount of wind affects the rate of evaporation of water.</p> <p>OR</p> <p>To find out if the presence / amount of wind affects the amount of water left in a beaker.</p> <p>c) The container reduced wind in the surrounding from entering the set-ups so that Shi Chen can be sure that the results of his experiment is only due to the presence of wind generated by the fan.</p>
Q38)	<p>a) B , C , A</p> <p>b) C: No</p> <p>E: Cup B is at the highest temperature after 5 mins / Cup B gains the most heat from the hot plate.</p> <p>C: Cup B will gain most heat from the coffee / gain heat from the coffee fastest.</p>

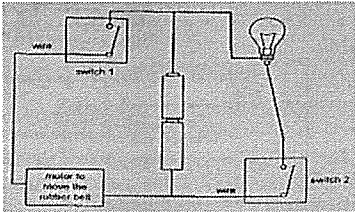
	<p>L: and lose most of the heat to the surrounding air / and lose the heat to the surrounding air fastest.</p> <p>OR</p> <p>C: No</p> <p>E: Cup B is at the highest temperature after 5 mins / Cup B gains the most heat from the hot plate.</p> <p>C: Cup B is the best conductor of heat.</p> <p>L: and will conduct most heat from the coffee to the surrounding air/ and will conduct heat from the coffee to the surroundings the fastest.</p>
<p>Q39)</p>	<p>a) Any one of the below.</p> <p>Move the cylinder closer to the touch.</p> <p>Move the cylinder further from the screen.</p> <p>Move the torch closer to the cylinder / screen.</p> <p>Move the screen further from the cylinder / torch.</p> <p>b) translucent / allows some light to pass through it.</p> <p>opaque / allows no light to pass through it.</p> <p>c)</p> <div style="display: flex; align-items: center; justify-content: center;"> <div style="border: 1px solid black; width: 30px; height: 20px; margin-right: 10px;"></div> <span style="margin: 0 10px;">or</span> <div style="border: 1px solid black; width: 30px; height: 20px; margin-left: 10px;"></div> </div>
<p>Q40)</p>	<p>a)</p>  <p>b) Yes. The motor and the bulb are connected in a parallel arrangement, electric current can still pass the motor / flow through the motor when the bulb fuses to move the rubber belt.</p>
<p>Q41)</p>	<p>a) i) True            ii) False</p> <p>b) Bulb Z will become dimmer / The brightness of bulb Z decreased.</p>