



RED SWASTIKA SCHOOL

2022 END OF YEAR EXAMINATION

MATHEMATICS PAPER 1

Name : _____ ()

Class : Primary 5 / _____

Date : 28 October 2022

BOOKLET A

15 Questions

20 Marks

Duration of Paper 1 (Booklets A & B): 1 hour

Note:

1. Do not open this Booklet until you are told to do so.
2. Read carefully the instructions given at the beginning of each part of the Booklet.
3. Do not waste time. If a question is difficult for you, go on to the next one.
4. Check your answers thoroughly and make sure you attempt every question.
5. In this booklet, you should have the following:
 - (a) Page 1 to Page 6
 - (b) Questions 1 to 15
6. You are not allowed to use a calculator.

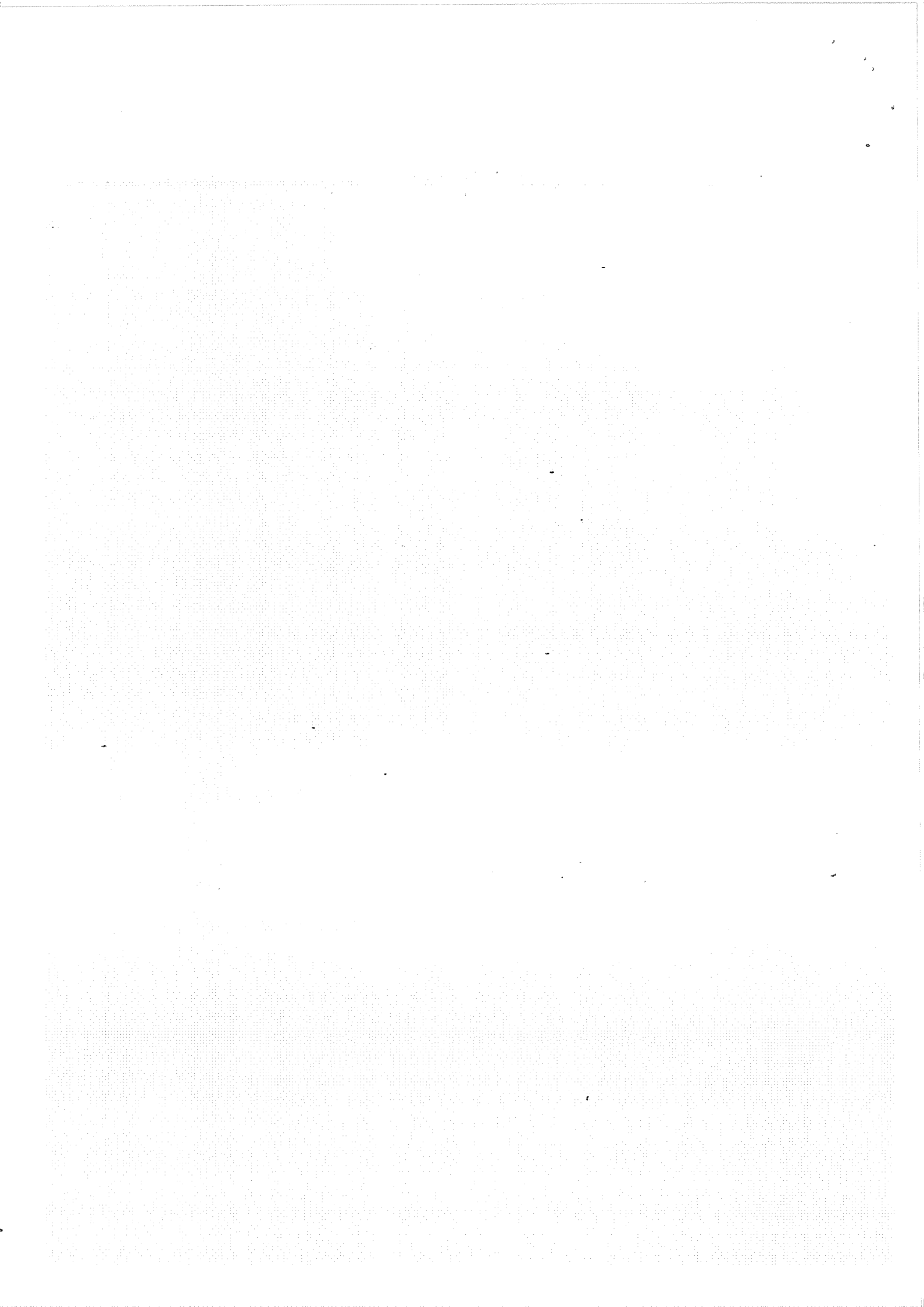

Questions 1 to 10 carry 1 mark each. Questions 11 to 15 carry 2 marks each. For each question, four options are given. One of them is the correct answer. Make your choice (1, 2, 3 or 4). Shade the correct oval (1, 2, 3 or 4) on the Optical Answer Sheet. (20 marks)

1 $7\,000\,000 + 800\,000 + 50\,000 + 9\,000 + 4 =$ _____

- (1) 785 904
- (2) 785 940
- (3) 7 859 004
- (4) 7 859 040

2 Which of the following has the same value as $22 \div 6$?

- (1) $1\frac{1}{3}$
- (2) $2\frac{1}{3}$
- (3) $3\frac{1}{3}$
- (4) $3\frac{2}{3}$

3 What is the distance between City A and City B?

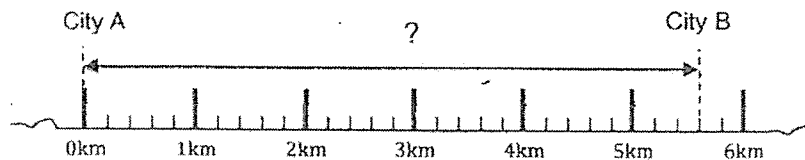

- (1) 5 km 300 m
- (2) 5 km 600 m
- (3) 6 km 300 m
- (4) 6 km 600 m

4 Find the value of 1.28×1000 .

- (1) 128
- (2) 1280
- (3) 12 800
- (4) 128 000

5 Mary had 1.5 kg of flour. She used 550 g of the flour. What was the amount of flour left?

- (1) 0.95 kg
- (2) 1.05 kg
- (3) 1.15 kg
- (4) 2.05 kg

6 In the figure below, not drawn to scale, ABC is a triangle inside a rectangle. Given that $AB = 6$ cm and $BC = 16$ cm, what is the area of triangle ABC?

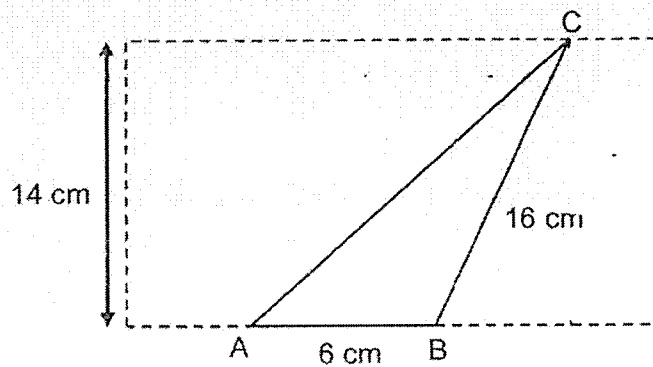

- (1) 42 cm^2
- (2) 48 cm^2
- (3) 84 cm^2
- (4) 96 cm^2

- 7 The cuboid has a square face which is shaded as shown.

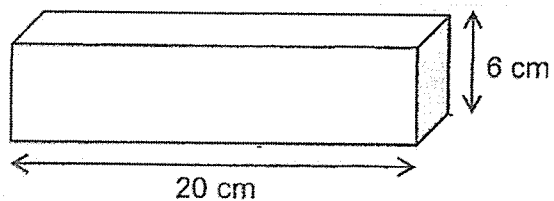

Find the volume of the cuboid.

- (1) 120 cm^3
(2) 240 cm^3
(3) 480 cm^3
(4) 720 cm^3
- 8 In the figure below, ABCD is a rectangle. $\angle BEF = 94^\circ$ and $\angle DFE = 46^\circ$. Find $\angle AEB$.

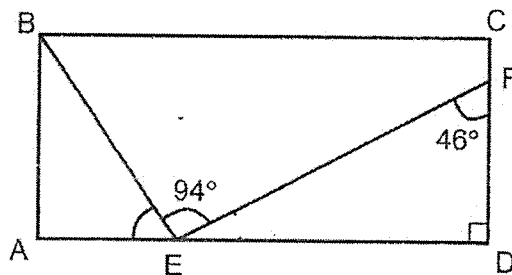

- (1) 40°
(2) 42°
(3) 43°
(4) 44°
- 9 There were 40 students at a picnic. 16 of them were boys. What was the ratio of the number of boys to the total number of students?
- (1) 2 : 3
(2) 2 : 5
(3) 3 : 2
(4) 5 : 2

10 Linda had \$130. She spent 60% of the money and saved the rest. How much did she save?

- (1) \$90
- (2) \$78
- (3) \$70
- (4) \$52

11 The figure is made up of a square and a triangle. Find the area of the figure.

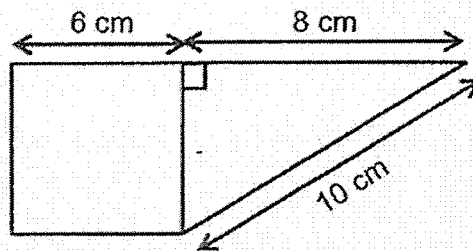

- (1) 36 cm^2
- (2) 60 cm^2
- (3) 66 cm^2
- (4) 84 cm^2

- 12 In the figure below, not drawn to scale, ABCD is a parallelogram, $\angle BAE = 50^\circ$ and $\angle DCE = 116^\circ$. Find $\angle AEC$.

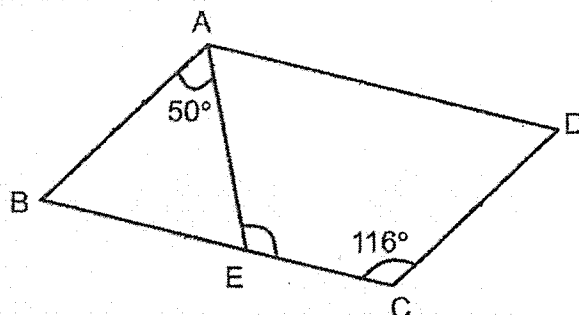

- (1) 64°
(2) 66°
(3) 114°
(4) 130°
- 13 80 students stand in a queue to collect cleaning tools at a Beach Cleanup Activity. There are at least 3 girls between every 2 boys. What is the largest number of boys in the queue?
- (1) 32
(2) 20
(3) 17
(4) 16
- 14 Sam used a special setting in his computer to control his gaming time as shown in the table below.

First 3 games	15 minutes per game
Every additional game	10 minutes

At most, how much time did he use to play 10 games?

- (1) 1 h 15 min
(2) 1 h 25 min
(3) 1 h 55 min
(4) 2 h 25 min

- 15 The figure is made up of identical squares.

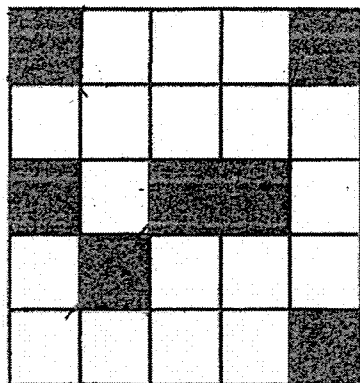

What is the least number of shaded squares that should **not** be shaded so that the figure has a line of symmetry?

- (1) 1
- (2) 2
- (3) 3
- (4) 4



RED SWASTIKA SCHOOL

2022 END OF YEAR EXAMINATION

MATHEMATICS PAPER 1

Name : _____ ()

Class : Primary 5 / _____

Date : 28 October 2022

BOOKLET B

15 Questions

25 Marks

In this booklet, you should have the following:

- (a) Page 7 to Page 13
- (b) Questions 16 to 30

MARKS

	OBTAINED	POSSIBLE
BOOKLET A	_____	20
BOOKLET B	_____	25
TOTAL	_____	45

Parent's Signature : _____

Questions 16 to 20 carry 1 mark each. Write your answers in the spaces provided. For questions which require units, give your answers in the units stated. (5 marks)

16 Find the value of $24 - (9 + 6) \div 3 \times 2$.

Ans: _____

17 Find the value of $18\,000 \div 500$.

Ans: _____

18 By joining the dots on the grid with straight lines, complete the drawing of a cuboid.

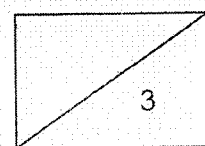
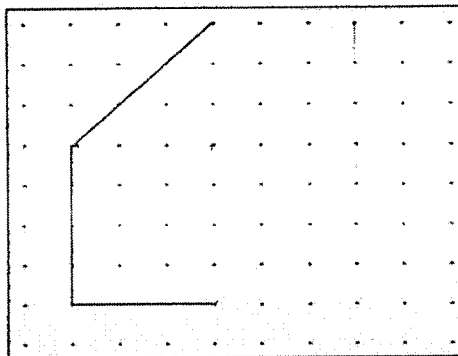

- 19 A lorry used 8ℓ of diesel to travel 32 km. At this rate, how many kilometres can the lorry travel on 1ℓ of diesel?

Ans: _____ km

- 20 By joining the dots on the grid below, draw a **straight line** AC such that AC is perpendicular to AB and AC is as long as AB.

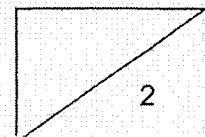
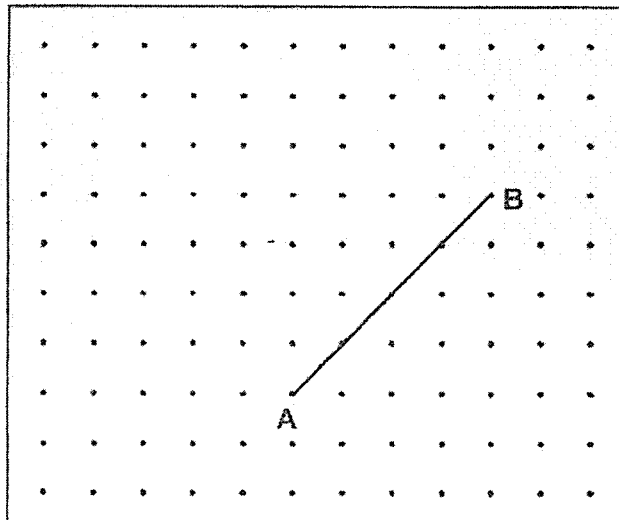

Questions 21 to 30 carry 2 marks each. Show your workings clearly in the space provided for each question and write your answers in the spaces provided. For questions which require units, give your answers in the units stated.

(20 marks)

21 Find the value of $\frac{9}{14} \times \frac{2}{3}$ as a fraction in its simplest form.

Ans: _____

22 (a) Find the value of 13.7×9 .

Ans: (a) _____

(b) Find the value of $24.8 \div 400$.

Ans: (b) _____

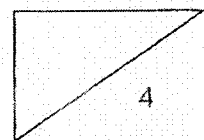

- 23 Mrs Li prepared 12ℓ of fruit juice to serve her guests at a party. After the party, she had $1\ell\ 150\text{ ml}$ of the fruit juice left. What was the amount of fruit juice that had been served during the party?

Ans: _____ ℓ

- 24 A wooden solid measuring 15 cm by 6 cm by 8 cm is shown below. What is the most number of 1-cm wooden cubes that can be cut out from the solid?

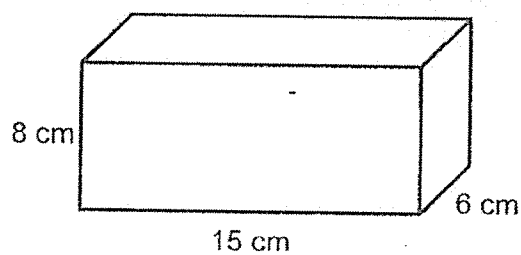

Ans: _____

10

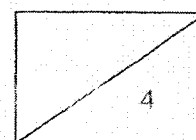

- 25 Raja collected 3 stamps on his first day of the stamp collection challenge. Each day, he collected 5 more stamps than the day before. He collected 43 stamps on the last day of the stamp collection challenge.

Day 1	Day 2	...	Last Day
3	8	...	43

- (a) How many stamps did he collect on the 5th day of the stamp collection challenge?

Ans: (a) _____

- (b) How many days were given for him to complete the challenge?

Ans: (b) _____

- 26 In the square grid below, AB is a straight line that forms one side of a rectangle ABCD.

- (a) Complete the drawing of rectangle ABCD such that AB is twice BC.

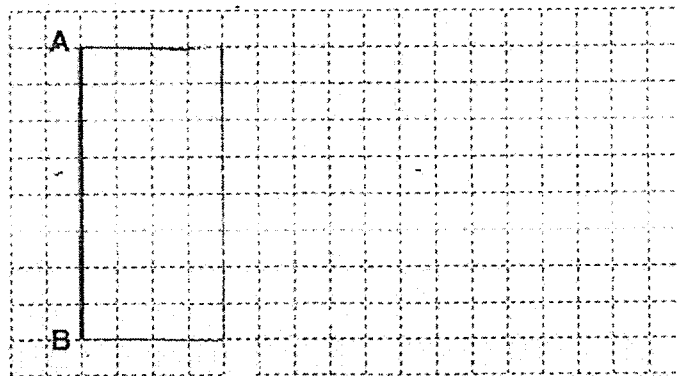

- (b) Measure the length of AB to the nearest centimetre.

Ans: (b) _____ cm

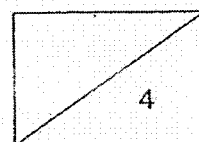

- 27 A bag contained a total of 240 red, blue and green beads. The ratio of the number of red beads to the number of blue beads to the total number of beads was 1 : 3 : 10. How many green beads were there in the bag?

Ans: _____

- 28 Lily had a monthly allowance of \$720. She saved $\frac{1}{4}$ of the allowance and spent $\frac{2}{3}$ of the allowance on food. She spent the remainder equally on transport and her hobby. How much did she spend on transport?

Ans: \$ _____

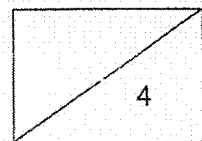

- 29 A rectangular tank measuring 50 cm by 20 cm by 24 cm and a cubical tank of sides 30 cm were shown below. Both tanks were empty.

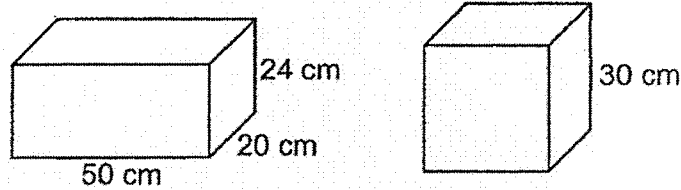

For both tanks to be $\frac{2}{3}$ filled with water, how many litres of water would be needed in total?

Ans: _____ ℓ

- 30 Peter was given 2 clocks. One of them was 10 minutes slower and the other was 10 minutes faster. He was only told that both clocks did not tell the correct time.

Based on the information above, each statement below is either true, false or not possible to tell. For each statement, put a tick (✓) in the correct column.

Statement	True	False	Not possible to tell
(a) At a certain time, Peter saw 12 50 on one clock and 13 15 on the other clock.			
(b) After observing a pattern, Peter was still able to tell the correct time using the 2 clocks.			

END OF PAPER

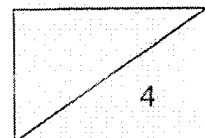



RED SWASTIKA SCHOOL

RED SWASTIKA SCHOOL

2022 END OF YEAR EXAMINATION

MATHEMATICS PAPER 2

Name : _____ ()

Class : Primary 5 / _____

Date : 28 October 2022

17 Questions

55 Marks

Duration of Paper 2: 1 hour 30 minutes

Note:

1. Do not open this Booklet until you are told to do so.
2. Read carefully the instructions given at the beginning of each part of the Booklet.
3. Do not waste time. If a question is difficult for you, go on to the next one.
4. Check your answers thoroughly and make sure you attempt every question.
5. In this paper, you should have the following:
 - (a) Page 1 to Page 13
 - (b) Questions 1 to 17
6. You are allowed to use a calculator.

MARKS

	OBTAINED	POSSIBLE
PAPER 1		45
PAPER 2		55
TOTAL		100

Parent's Signature : _____

Questions 1 to 5 carry 2 marks each. Show your workings clearly in the space below each question and write your answers in the spaces provided. For questions which require units, give your answers in the units stated.

(10 marks)

- 1 What is the average of 8, 12, 29 and 36?

Ans: _____

- 2 The figure is made up of 2 triangles such that $AD = 15$ cm, $CD = 13$ cm and $BC = 12$ cm. Find the area of the shaded triangle ABC.

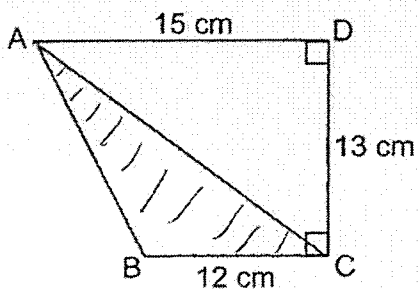

Ans: _____ cm^2

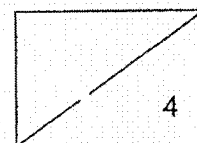

- 3 In the figure below, AB and CD are straight lines. Find $\angle m$.

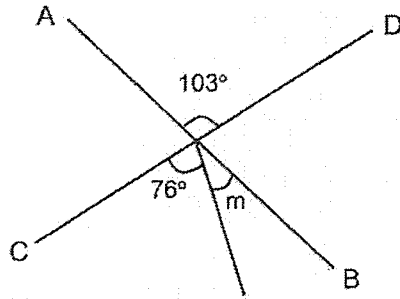

Ans: _____

- 4 On the grid below, some figures were drawn using straight lines. Name a parallelogram and a trapezium.

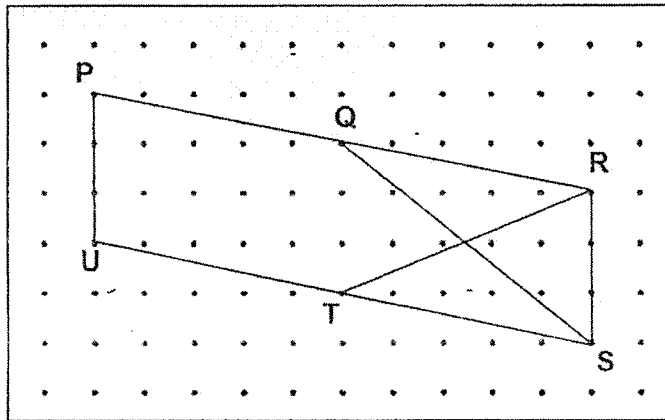

(a) _____ is a parallelogram.

(b) _____ is a trapezium.

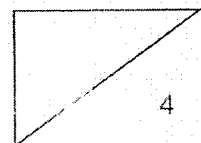

- 5 The table shows the rates for renting a bicycle from a shop.

First 2 hours	\$12
After the second hour	\$5 per hour or part thereof

Ali rented a bicycle from 10 15 to 14 30. How much did he have to pay?

Ans: \$ _____

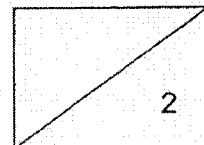

For Questions 6 to 17, show your workings clearly in the space below each question and write your answers in the spaces provided. The number of marks available is shown in brackets [] at the end of each question or part-question.

(45 marks)

-
- 6 The total cost of a bag and 3 files was \$65. The cost of the bag was twice the cost of each file. What was the cost of the bag?

Ans: _____ [3]

-
- 7 May prepared 270 red, yellow and blue balloons for a party. $\frac{5}{9}$ of the balloons were red, $\frac{2}{5}$ of the remainder were yellow and the rest were blue. How many balloons were blue?

Ans: _____ [3]

4

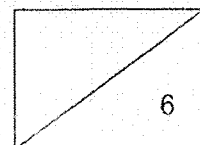

- 8 A straight pathway was covered with identical tiles in a pattern. The length of each tile was 45 cm. The pattern with the starting and ending of the pathway was shown below. The whole pathway required 5000 such tiles.

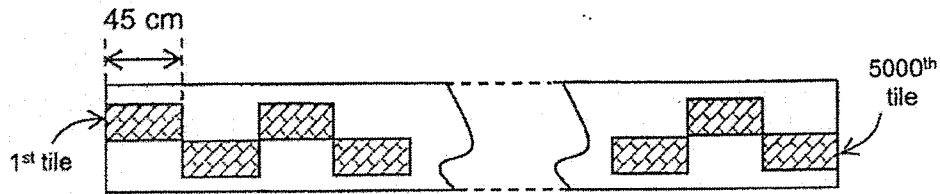

- (a) What was the length of each tile in metres?

Ans: (a) _____ m [1]

- (b) What was the length of the pathway in kilometres?

Ans: (b) _____ km [2]

- 9 At a factory, one machine took 2 minutes while another machine took 3 minutes to make 6 bottles. Both machines started and stopped making bottles at the same time.

- (a) How many more bottle(s) was/were made by the faster machine than the slower machine per minute?

Ans: (a) _____ [1]

- (b) How many bottles were made in 10 minutes by both machines?

Ans: (b) _____ [2]

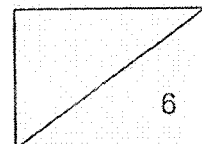

- 10 The table and the bar graph were used to record the number of computers sold for 4 months. However, the reading for the 2nd month was missing in the table and the bar was missing for the 4th month in the bar graph.

Table

Month	1st	2nd	3rd	4th
Number of computers sold	24		20	18

Bar Graph

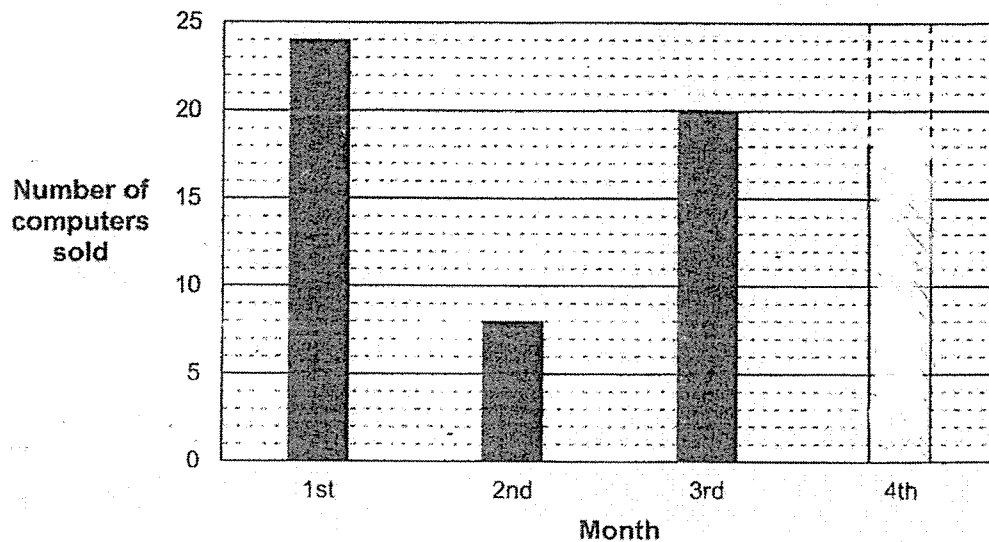

- (a) Complete the record by entering the number of computers sold for the 2nd month in the table and drawing the bar for the 4th month. [1]
- (b) The average number of computers sold from the 1st month to the 5th month was 19. How many computers were sold in the 5th month?

Ans: (b) _____ [2]

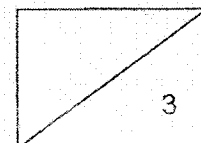

- 11 In the figure below, ABC is an equilateral triangle, BCD is a straight line, AD = AE, $\angle DAE = 36^\circ$ and $\angle CDA = 32^\circ$.

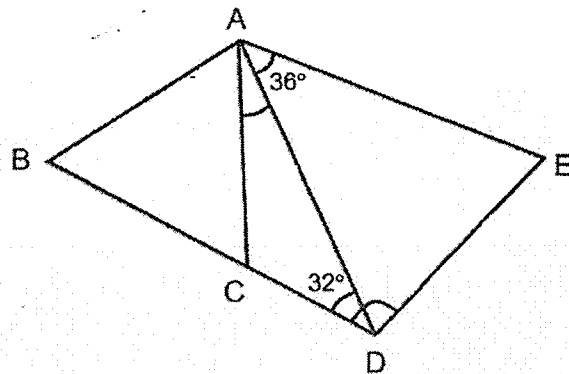

- (a) Find $\angle CDE$.

Ans: (a) _____ [2]

- (b) Find $\angle CAD$.

Ans: (b) _____ [1]

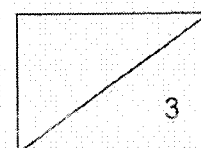

Sale



**First pair of shoes
at 40% discount**



**Second pair of shoes
at 55% discount**

Tom bought 2 pairs of shoes. Before discount, the price of the first pair of shoes was \$245 and the price for the second pair of shoes was \$150.

(a) What was the discount for the first pair of shoes?



Ans: (a) _____ [2]

(b) What was the price of the second pair of shoes after the discount?

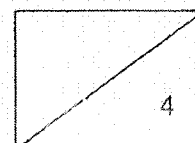
Ans: (b) _____ [2]



- 13 The table shows the prices of cupcakes that are sold at a shop.

<p>1 pack of 3 cupcakes</p>  <p>\$4.90</p>	<p>1 cupcake</p>  <p>\$1.85</p>
---	--

Mrs Tan has \$29 to buy cupcakes at this shop. What is the most number of cupcakes she can buy?

Ans: _____ [5]

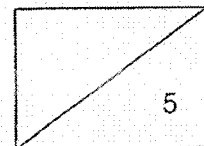

14 The average of four 3-digit numbers is 348. The first 2 numbers are 255 and 160.

(a) What is the average of the 3rd and 4th numbers?

Ans: (a) _____ [3]

(b) What is the largest difference between the 3rd and the 4th number?

Ans: (b) _____ [2]

10

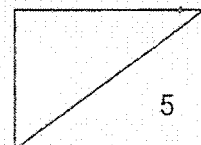

- 15 A rectangle is made up of 3 triangles, A, B and C as shown.
The ratio of the area of triangle A to the area of triangle C is 5 : 12.

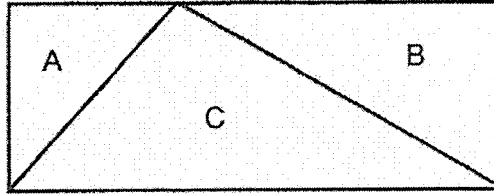

- (a) - What is the ratio of the area of triangle A to the area of triangle B to the area of triangle C?

Ans: (a) _____ [1]

- (b) The area of triangle A is 80 cm^2 . Find the area of the rectangle.

Ans: (b) _____ [3]

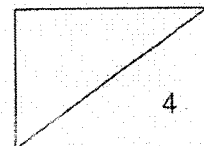

- 16 Two boys used the same number of ice cream sticks to make toy cars. Han used $\frac{2}{7}$ of his ice cream sticks while Jay used $\frac{3}{4}$ of his ice cream sticks. They had a total of 8120 ice cream sticks at first. How many ice cream sticks did each boy use?

Ans: _____ [4]

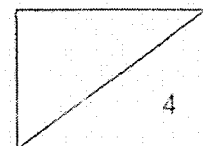

- 17 A box contained blue beads and red beads. At first, there were 5 times as many blue beads as red beads. After 28 blue beads and 28 red beads were removed, the difference in the number of blue beads and red beads left in the box was 260.

(a) How many blue beads were there in the box at first?

Ans: (a) _____ [3]

(b) What was the total number of beads left in the box?

Ans: (b) _____ [2]

END OF PAPER

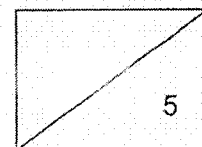

ANSWER KEY

YEAR : 2022
LEVEL : Primary 5
SCHOOL : Red Swastika School
SUBJECT : MATHEMATICS
TERM : End of Year Examination

Paper 1 Booklet A

Q1	3	Q2	4	Q3	2	Q4	2	Q5	1
Q6	1	Q7	4	Q8	2	Q9	2	Q10	4
Q11	2	Q12	3	Q13	2	Q14	3	Q15	2

Booklet B

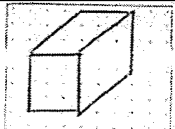
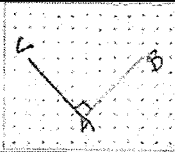
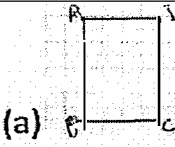
Q16	Ans : 14	Q17	Ans : 36
Q18		Q19	$32 \div 8 = 4$ Ans : 4
Q20		Q21	$\frac{9}{14} \times \frac{2}{3} = \frac{3}{7}$ Ans: $\frac{3}{7}$
Q22	Ans : (a) 123.3 (b) 0.062	Q23	$12 - 1.15 = 10.85$ Ans : 10.85
Q24	$8 \times 15 \times 6 = 720$ Ans : 720	Q25	(a) $5 - 2 = 3$ $5 \times 3 = 15$ $8 + 15 = 23$ (b) $43 - 3 = 40$ $40 \div 5 = 8$ $8 + 1 = 9$ Ans : (a) 23 (b) 9
Q26	 (a) Ans : (b) 4	Q27	$240 \div 5 = 48$ $48 \times 2 = 96$ $240 - 96 = 144$ Ans : 144
Q28	$720 \div 12 = 60$ $60 \div 2 = 30$ Ans : 30	Q29	$50 \times 20 \times 24 \times \frac{2}{3} = 16000$ $30 \times 30 \times 30 \times \frac{2}{3} = 18000$

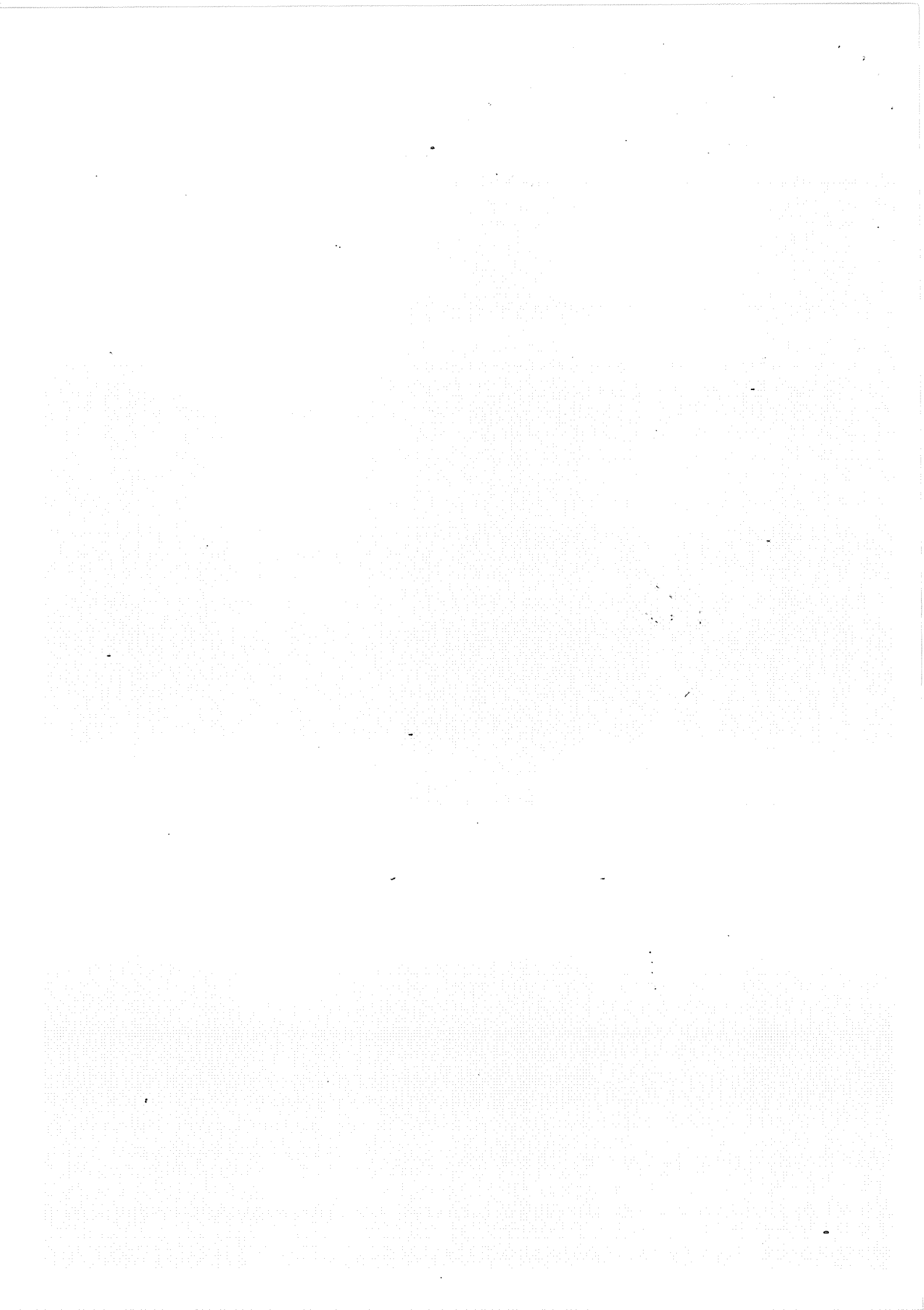

			18000+16000=34000 Ans : 34
Q30	(a) False (b) False		

Paper 2

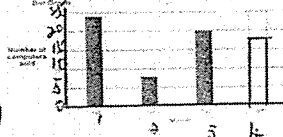
Q1	Ans : 21.25	Q2	$\frac{1}{2} \times 12 \times 13 = 78$ Ans : 78
Q3	103-76=27 Ans : 27	Q4	(a) PRSU (b) PUSQ
Q5	12+(5×2)+5=27 Ans : 27	Q6	65÷5=13 13×2=26 Ans : \$26
Q7	270÷9=30 30×4=120 120÷5=24 24×3=72 Ans : 72	Q8	(a) 0.45 (b) 0.45×5000=2250 2250m=2.25km Ans : (a) 0.45 (b) 2.25
Q9	(b) 30+20=50 Ans : (a) 1 (b) 50	Q10	 (a) (b) 19×5=95 24+8+20+18=70 95-70=25 Ans : (b) 25
Q11	(a) (180-36)÷2=72 72+32=104 (b) 180-60=120 180-120-32=28 Ans : (a) 104° (b) 28°	Q12	(a) $\frac{40}{100} \times 245 = 98$ (b) $\frac{45}{100} \times 150 = 67.50$ Ans : (a) \$98 (b) \$67.50
Q13	29÷4.90=5R4.5 5×3=15 4.90×5=24.50 29-24.50=4.50 4.50÷1.85=2R0.8 15+2=17 Ans : 17	Q14	(a) 348×4=1392 1392-255-160=977 977÷2=488.5 (b) 977-100=877 877-100=777 Ans : (a) 488.5 (b) 777
Q15	(a) 5 : 7 : 12	Q16	8120÷29=280

	(b) $80 \div 5 = 16$ $16 \times 24 = 384$ Ans : (a) 5 : 7 : 12 (b) 384cm^2		$280 \times 6 = 1680$ Ans : 1680
Q17	(a) $260 \div 4 = 65$ $65 \times 5 = 325$ (b) $65 - 28 = 37$ $325 - 28 = 297$ $37 + 297 = 334$ Ans : (a) 325 (b) 334		

3
END