



**RAFFLES GIRLS' PRIMARY SCHOOL
WEIGHTED ASSESSMENT 1 2022
MATHEMATICS
PRIMARY 5**

Name: Form _____ ()

Class: P5 Date: _____

Math Teacher: _____

22 April 2022

Duration: 50 minutes

Your Total Score (Out of 32 marks)	
Parent's Signature	

INSTRUCTIONS TO CANDIDATES

1. Do not turn over this page until you are told to do so.
2. Follow all instructions carefully.
3. Answer **ALL** questions and show all working clearly.
4. The use of calculator is allowed for this paper.

Questions 1 and 2 carry 1 mark each and Questions 3 to 9 carry 2 marks each.
Show your working clearly in the space provided for each question and write your answers
in the spaces provided.

For questions which require units, give your answers in the units stated.

All diagrams are not drawn to scale.

[16 marks]

1. In triangle ABC, if the base is AC, the height is _____.

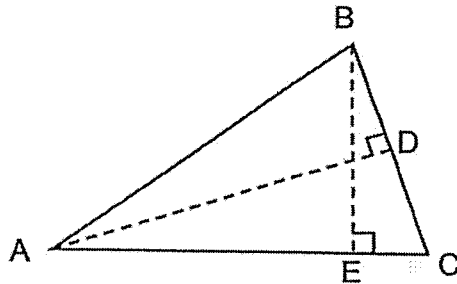

Ans: _____ [1]

2. Terry had 4 ℓ of orange juice. He poured the orange juice equally into 6 cups. How much orange juice was there in each cup? Give your answer in the simplest form.

Ans: _____ ℓ [1]

3. Find the area of shaded triangle.

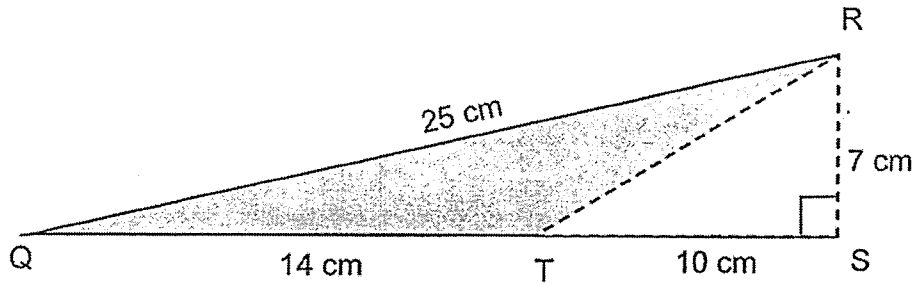

Ans: _____ cm² [2]

4. The length of a rectangle is $5\frac{1}{12}$ m. The breadth of the rectangle is 2 m less than its length. Find the perimeter of the rectangle. Give your answer in the simplest form.

Ans: _____ m [2]

5. Find the area of the shaded part.

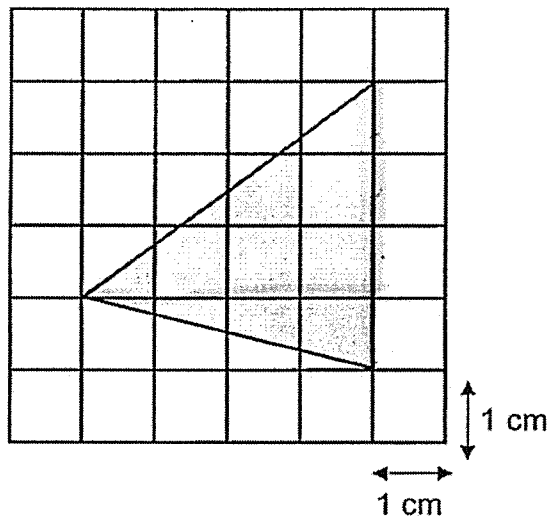

Ans: _____ cm² [2]

6. Jane had 1400 g of chicken. She used $\frac{1}{7}$ of the chicken to make a pie. How much chicken had she left?

Ans: _____ g [2]

7. In the figure, ABCD is a rectangle. Find the area of the unshaded part.

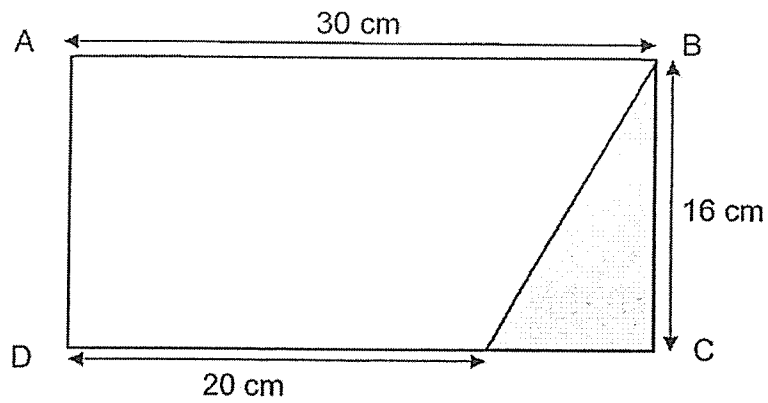

Ans: _____ cm² [2]

8. Mrs Tan had $\frac{5}{6}$ m of cloth. She used $\frac{1}{3}$ of the cloth to sew a bag and $\frac{1}{6}$ m to sew a handkerchief. How much cloth had she left?

[2] Ans: _____ m

9. A is a square and B is a rectangle. The length of B is 3 times its breadth. Find the area of rectangle B.

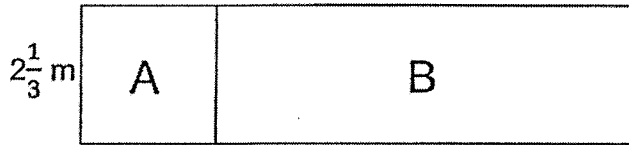

Ans: _____ m² [2]

For questions 10 to 13, show your working clearly in the space provided for each question and write your answers in the spaces provided.
 The number of marks available is shown in the brackets [] at the end of each question or part-question. All diagrams are not drawn to scale. [16 marks]

10. ABCD is a square of length 12 cm. BD is a straight line. GF is 2 cm. EF is $\frac{1}{4}$ of BC.
 Find the area of the shaded part.

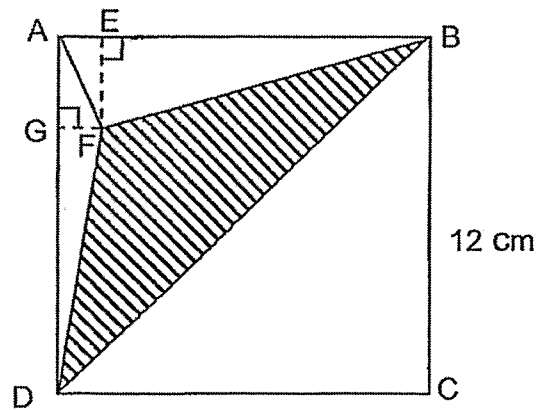

Ans: _____ [4]

11. Jim spent $\frac{3}{5}$ of his salary on transport and spent $\frac{1}{8}$ of the remaining salary on food. He gave $\frac{1}{10}$ of his salary to his mother and had \$1325 left.

(a) What fraction of his salary did he spend on food?

(b) What was the amount of his salary?

Ans: (a) _____ [1]

(b) _____ [2]

12. A square piece of paper was folded to form the shape as shown.
Find the area of the shaded part.

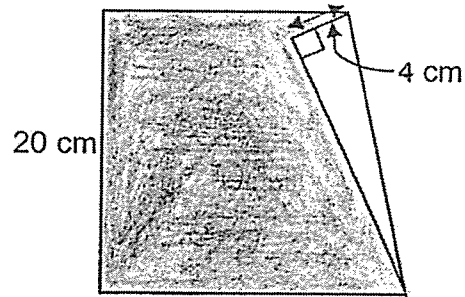

Ans: _____ [4]

13. At a concert, $\frac{5}{12}$ of the people were students and the rest were adults. $\frac{3}{4}$ of the adults were women. 70 men attended the concert. The cost of an adult ticket was \$165 while the cost of a student ticket was $\frac{4}{5}$ of the cost of an adult ticket.

(a) What was the cost of 1 student ticket?

(b) What was the amount of money collected from the sales of the student tickets?

Ans: (a) _____ [1]

(b) _____ [4]

END OF PAPER

SCHOOL : RAFFLES GIRLS' PRIMARY SCHOOL
 LEVEL : PRIMARY 5
 SUBJECT : MATH
 TERM : 2022 WA1

Q1)	BE
Q2)	$\frac{2}{3}$
Q3)	$\frac{1}{2} \times 14 \times 7 = 49 \text{ cm}^2$
Q4)	$5\frac{1}{12} + 5\frac{1}{12} + 3\frac{1}{12} + 3\frac{1}{12} = 16\frac{1}{3} \text{ m}$
Q5)	Formula $\rightarrow \frac{1}{2} \times \text{base} \times \text{height}$ Shaded area $\rightarrow \frac{1}{2} \times 4 \times 4 = 8 \text{ cm}^2$
Q6)	$\frac{7}{7} - \frac{1}{7} = \frac{6}{7}$ $1400 \times \frac{6}{7} = 1200$
Q7)	Shaded $\rightarrow \frac{1}{2} \times 10 \times 16 = 80$ ABCD $\rightarrow 30 \times 16 = 480$ Unshaded $\rightarrow 480 - 80 = 400 \text{ CM}^2$
Q8)	$\frac{5}{6} \times \frac{1}{3} = \frac{5}{18} \text{ M}$ $\frac{5}{6} - \frac{5}{18} = \frac{5}{9} \text{ M}$ $\frac{5}{9} - \frac{1}{6} = \frac{7}{18} \text{ M}$

Q9)	$1U \rightarrow 2\frac{1}{3}$ $3U \rightarrow 2\frac{1}{3} \times 3 = 7$ $\text{Rec B} \rightarrow 7 \times 2\frac{1}{3} = 16\frac{1}{3} \text{ m}^2$
Q10)	$EF \rightarrow 12 \times \frac{1}{4} = 3$ $ABF \rightarrow \frac{1}{2} \times 12 \times 3 = 18$ $AFD \rightarrow \frac{1}{2} \times 2 \times 12 = 12$ $ABD \rightarrow \frac{1}{2} \times 12 \times 12 = 72$ $\text{Shaded} \rightarrow 72 - 12 - 18 = 42 \text{ cm}^2$
Q11)	a) $\frac{1}{20}$ b) $5u \rightarrow 1325$ $1u \rightarrow 1325 \div 5 = 265$ $20u \rightarrow 265 \times 20 = \5300
Q12)	$\text{Unshaded} \rightarrow \frac{1}{2} \times 4 \times 20 = 40$ $\text{Unshaded} \rightarrow 40 \times 2 = 80$ $\text{Square} \rightarrow 20 \times 20 = 400$ $\text{Shaded} \rightarrow 400 - 80 = 320 \text{ cm}^2$

Q13)	a) $165 \times \frac{4}{5} = \132 b) $7u \rightarrow 70$ $1u \rightarrow 70 \div 7 = 10$ $20u \rightarrow 10 \times 20 = 200$ $\rightarrow 200 \times 132 = \26400
------	----------------------------------------------------------------------------------------------------------------------------------------------------------------------------------------