

METHODIST GIRLS' SCHOOL

Founded in 1887



PRIMARY 4
SCIENCE

Total Time for Booklets A and B: 1 hour 30 minutes

INSTRUCTIONS TO CANDIDATES

Do not turn over this page until you are told to do so.

Follow all instructions carefully.

Answer all questions.

Shade your answers in the Optical Answer Sheet (OAS) provided.

Name: _____ ()

Class: Primary 4. _____

Date :

P4 Timed Practice Paper
Section A

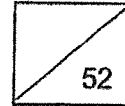

Name: _____ ()

Date: _____

Class: 4. _____

Parent's Signature: _____

For each question from 1 to 26, four options are given. One of them is the correct answer. Make your choice (1, 2, 3 or 4). Shade the correct oval on the Optical Answer Sheet (OAS).
[52 marks]

1 Which one of the following is not a living thing?

(1)

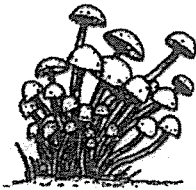

(2)



(3)

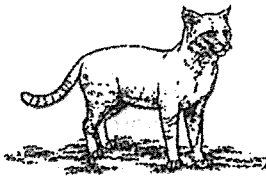

(4)



2 The diagram below shows a dog barking at a butterfly.



This shows that the dog is a living thing because it can _____.

- (1) grow
- (2) breathe
- (3) respond
- (4) reproduce

- 3 The diagram below shows a water hose connected to a tap.

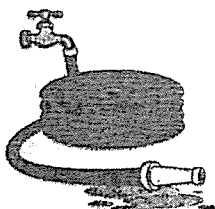

Water can flow through the coiled water hose because it _____.

- (1) has mass.
 - (2) has definite volume.
 - (3) has no definite shape.
 - (4) cannot be compressed.
- 4 The chart below shows how substance Z, oxygen and carbon dioxide are transported in a human body.

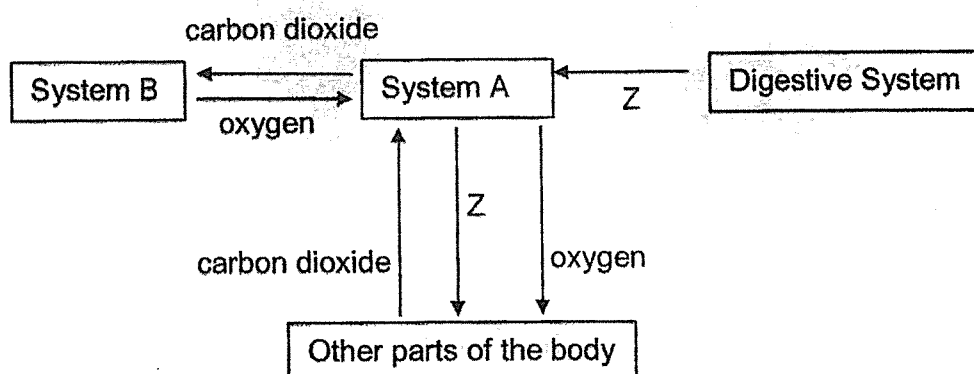

What are systems A and B and substance Z?

| | System A | System B | Substance Z |
|-----|-------------|-------------|----------------|
| (1) | respiratory | circulatory | digested food |
| (2) | circulatory | respiratory | digested food |
| (3) | muscular | circulatory | oxygen |
| (4) | circulatory | respiratory | carbon dioxide |

5 Study the chart below.

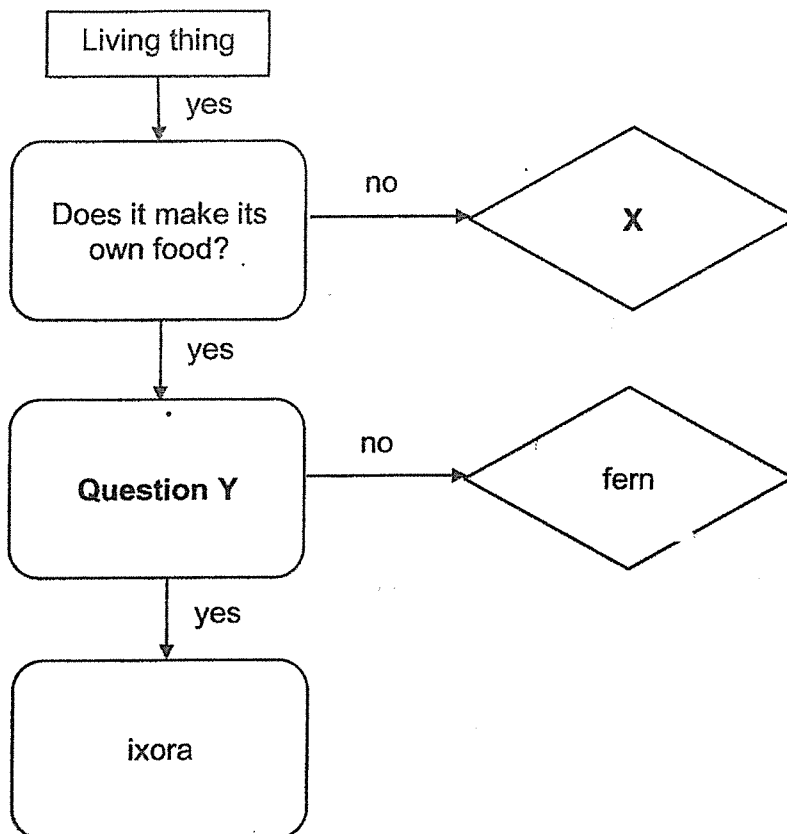

- (1)
- (2)
- (3)
- (4)

Which one of the following is correct?

| | X | Question Y |
|-----|----------|------------------------|
| (1) | mould | Does it produce seeds? |
| (2) | mushroom | Does it have roots? |
| (3) | moss | Does it have fruits? |
| (4) | rose | Does it need water? |

6 Which part of the human digestive system listed below absorbs all the digested food?

- (1) stomach
- (2) small intestine
- (3) large intestine
- (4) anus

7 Which one of the following is not matter?

- (1) star
- (2) sound
- (3) smoke
- (4) sponge

8 The diagram below shows two plants.

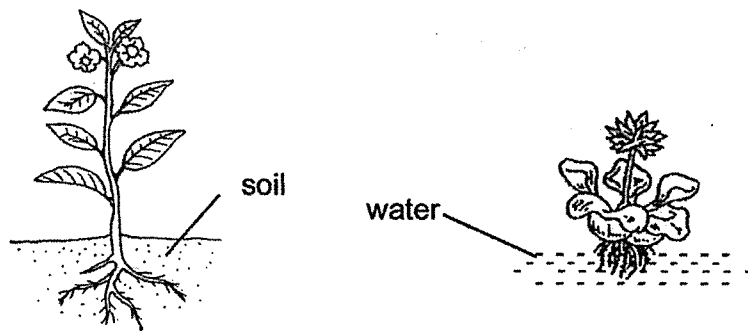

Which one of the following statements explains correctly the function of roots for both the plants above?

- (1) The roots support the plants upright.
- (2) The roots take in mineral salts for the plants.
- (3) The roots hold the plants firmly to the ground.
- (4) The roots spread out to receive more sunlight.

- 9 Ms Tan prepared three set-ups, X, Y and Z, using identical plants as shown in the diagram below. Each container had the same amount of water and a layer of oil. Ms Tan placed the three set-ups near a window and observed the amount of water left in the beaker after a week.

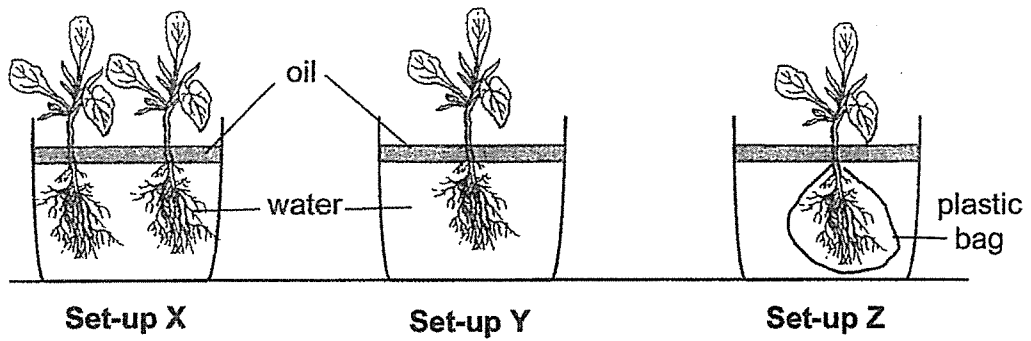

Which one of the following most likely shows the amount of water left in each container at the end of a week?

(1)

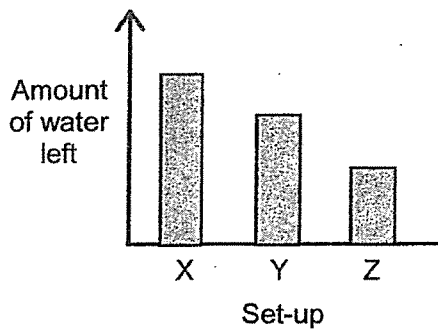

(2)

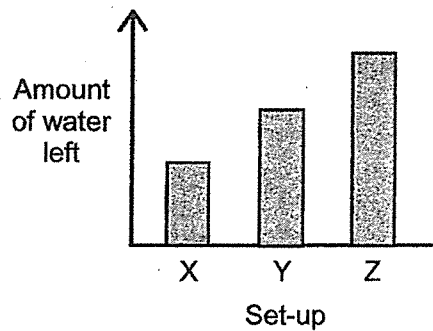

(3)

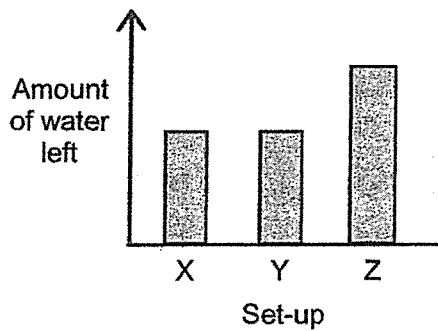

(4)

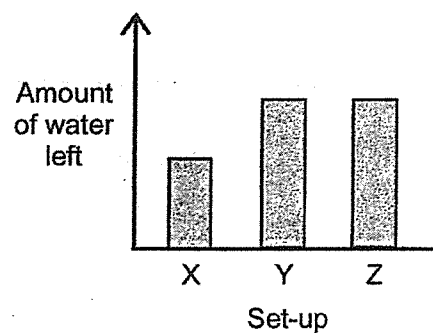

- 10 The diagram below shows the life cycle of an animal.

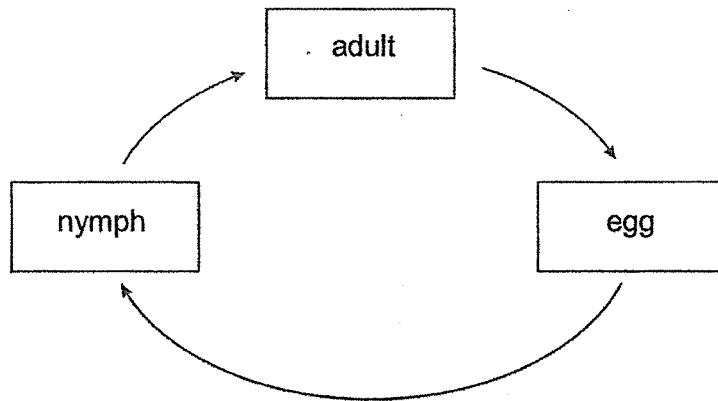

Which animal is likely to have the life cycle as shown above?

- (1) chicken
 - (2) frog
 - (3) housefly
 - (4) cockroach
- 11 The diagram below shows stages in the life cycle of an insect.

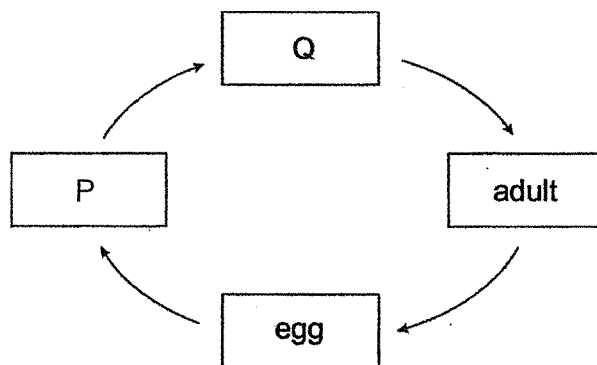

Which of the following correctly describes the insect at stages P and Q?

| | Stage P | Stage Q |
|-----|------------------|--------------------------|
| (1) | moves a lot | does not move |
| (2) | looks like adult | does not look like adult |
| (3) | does not moult | moults several times |
| (4) | able to fly | unable to fly |

- 12 John filled a syringe with some oil and air. He covered one end of the syringe and tried to push the plunger down.

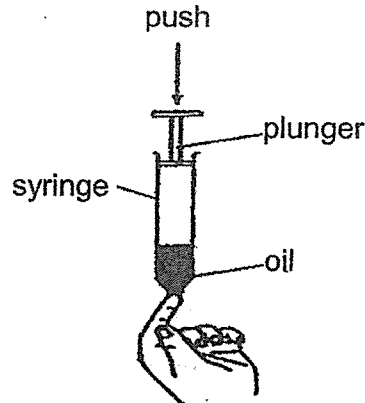

John could not push in the plunger completely. Which of the following explain his observation?

- A Air takes up space.
 B Oil has a definite volume.
 C Oil has no definite shape.
 D Air has no definite shape.
- (1) A and B only
 (2) A and D only
 (3) B and C only
 (4) C and D only
- 13 The animals are classified into two groups as shown below.

| Group Y | Group Z |
|-----------------|-------------|
| mosquito | grasshopper |
| mealworm beetle | chicken |

What is/are the possible heading(s) for groups Y and Z?

| | Group Y | Group Z |
|---|---------------------------------------|--------------------------------------|
| A | The young do not resemble adult | The young resemble adult |
| B | Have wings in the adult stage | Do not have wings in the adult stage |
| C | Spend part of the life cycle in water | Spend the whole life cycle on land |

- (1) A only
 (2) B only
 (3) B and C only
 (4) A and C only

14 Study the flowchart below.

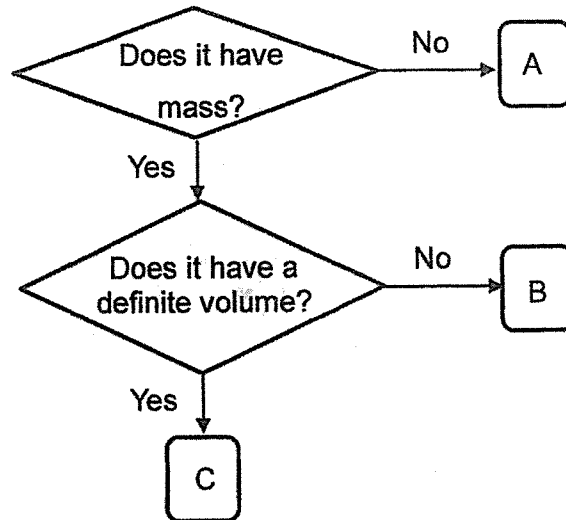

Which one of the following best represents A, B and C?

| | A | B | C |
|-----|----------|----------|----------|
| (1) | air | oxygen | ice |
| (2) | heat | water | air |
| (3) | shadow | oxygen | ice |
| (4) | light | ice | air |

15 The diagram below shows a shelf.

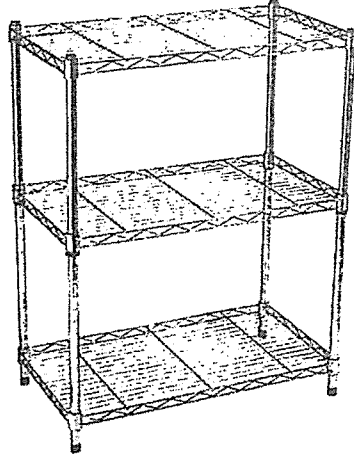

Metal is used to make the shelf because metal _____.

- (1) is shiny
- (2) can reflect light
- (3) does not break easily
- (4) is a good conductor of heat

16 Which one of the following can be attracted by a magnet?

- (1) steel ruler
- (2) rubber ball
- (3) glass marble
- (4) wooden spoon

17 Which one of the following is a source of light?

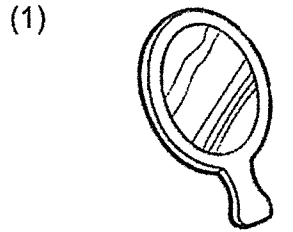

a mirror

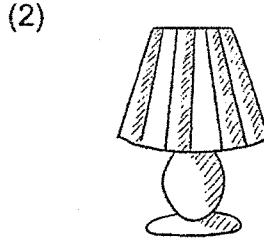

a lamp

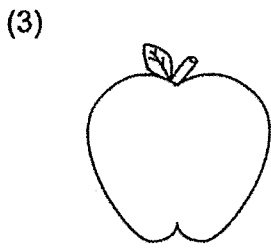

an apple

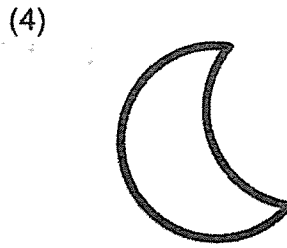

the moon

18 Which diagram below shows repulsion between two magnets?

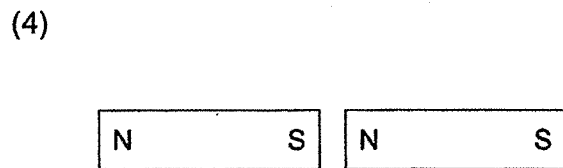
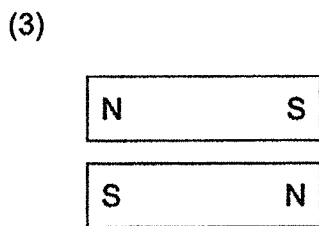
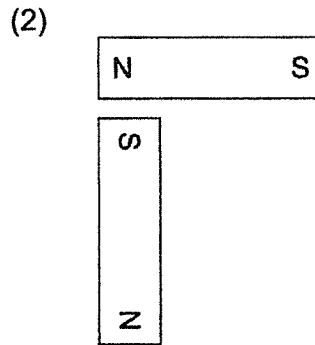
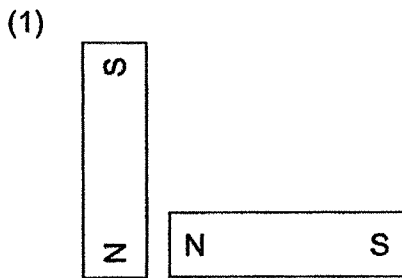

- 19 Zakiah placed an ice cube into a cup of water as shown below.

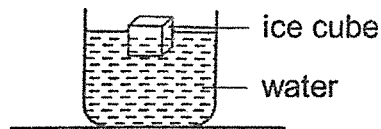

The ice melted after a while.

Which one of the following explains Zakiah's observation?

- (1) The cup loses heat to the water.
- (2) The water gains heat from the ice.
- (3) The ice cube gains heat from the water.
- (4) The ice cube loses heat from the water.

- 20 Bars C, D, E and F were hung on a rod and the observations are shown below.

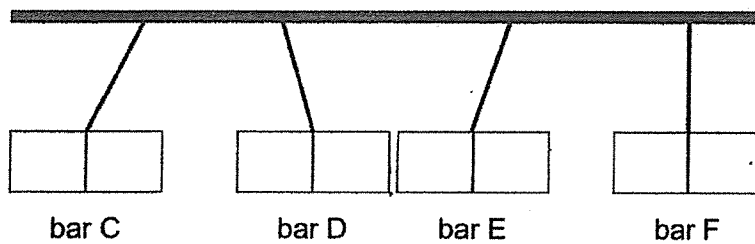

Which of the following statements are true?

- W Bar C is a magnet.
- X Bar D is made of copper.
- Y Bar E can be a magnetic material.
- Z Bar F can be a non-magnetic material.

- (1) W and Z only
- (2) X and Y only
- (3) W, Y and Z only
- (4) All of the above

- 21 Four identical cubes made of different materials A, B, C and D were weighed before they were placed into four containers containing equal amount of water.

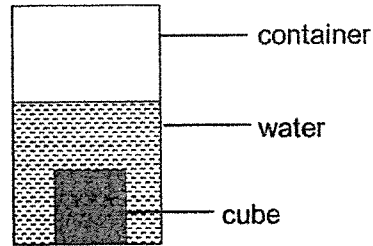

After 10 minutes, each cube was weighed again. Their masses were recorded in the table below.

| Material | Mass at the beginning (g) | Mass after 10 minutes |
|----------|---------------------------|-----------------------|
| A | 12 | 14 |
| B | 7 | 14 |
| C | 13 | 18 |
| D | 10 | 10 |

Which material is the most suitable to make a raincoat and towel?

| | Raincoat | Towel |
|-----|----------|-------|
| (1) | A | C |
| (2) | B | D |
| (3) | C | D |
| (4) | D | B |

- 22 Two empty flasks, P and Q, are connected by a glass tube as shown below. There is a drop of ink in the tube.

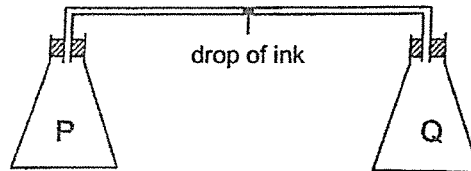

Which of the following actions will cause the drop of ink to move towards flask P?

- W Place flask P in a basin of ice.
- X Place flask Q in a basin of ice.
- Y Place flask P in a basin of hot water.
- Z Place flask Q in a basin of hot water.

- (1) W and X only
- (2) X and Y only
- (3) W and Z only
- (4) Y and Z only

- 23 Melting heated cube G and H to the same temperature as shown below. Cube G and H are made of the same material.

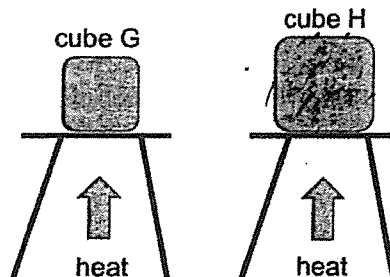

Which one of the following statements is correct?

- (1) Cube G has more heat energy as it gained heat faster.
- (2) Cube G has less heat energy as compared to cube H.
- (3) Cube H has less heat energy as compared to cube G.
- (4) Cube H has more heat energy as it lost heat faster.

- 24 The diagram below shows blobs of wax, A, B, C and D, which are placed onto a triangular piece of metal.

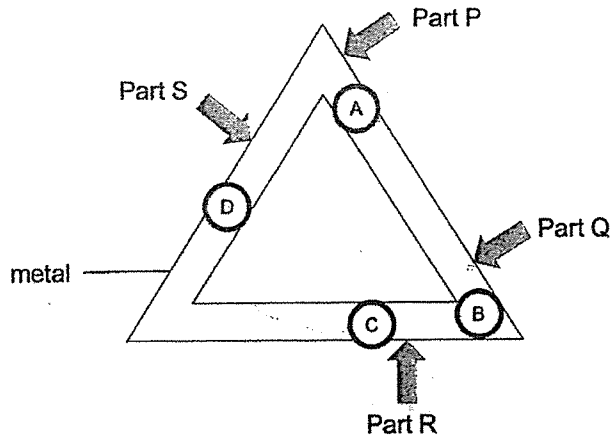

When a certain position of the metal piece is heated, the blobs of wax melt in the order of B, C, A, D. Which position, P, Q, R or S, is the metal piece heated?

- (1) P
 (2) Q
 (3) R
 (4) S
- 25 A cup of hot chocolate was left in a room for 40 minutes. Which one of the graphs represents the changes in temperature that took place in the cup of hot chocolate?

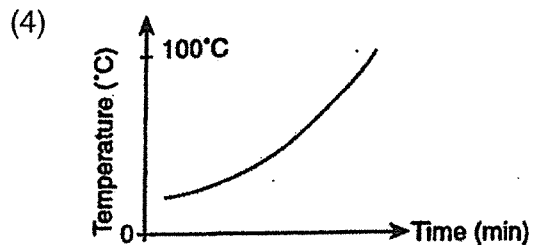
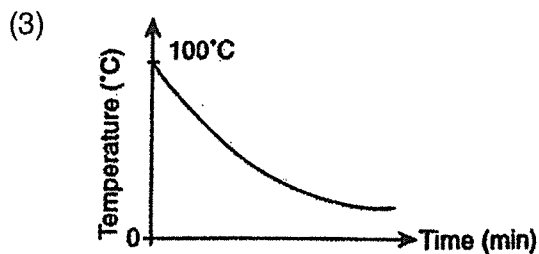
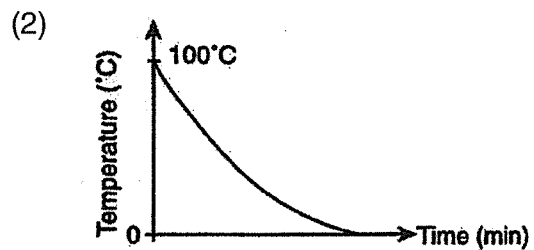
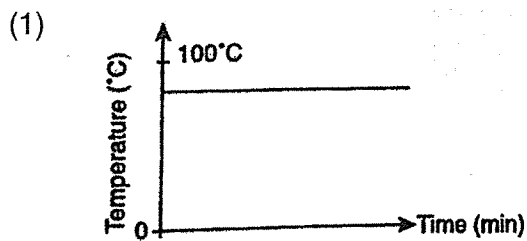

26 Ron placed object W behind three different materials, R, S and T.

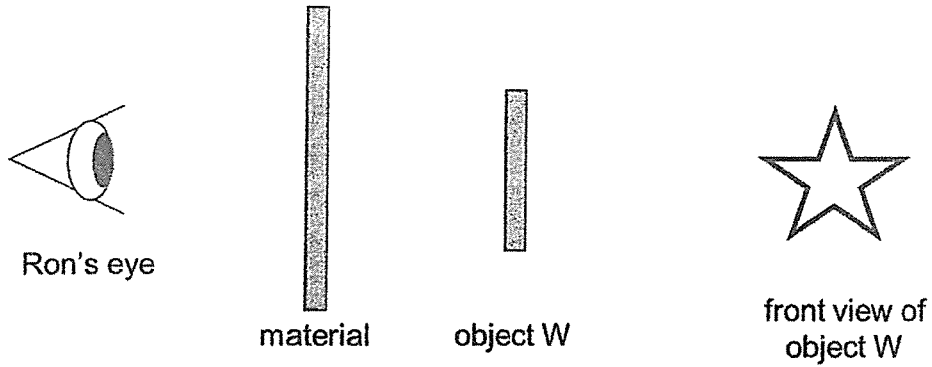

He drew what he could see as shown below.

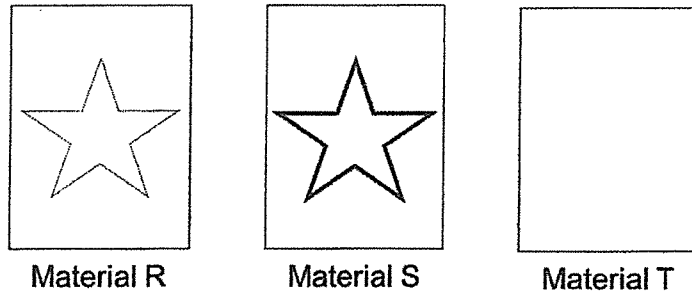

Which one of the following properties describe the materials correctly?

| | No light can pass through | Some light can pass through | Most light can pass through |
|-----|---------------------------|-----------------------------|-----------------------------|
| (1) | R | S | T |
| (2) | T | R | S |
| (3) | S | R | T |
| (4) | T | S | R |

P4 Timed Practice Paper
Section B

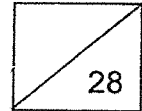

Name: _____ ()

Date: _____

Class: 4. _____

Parent's Signature: _____

For questions 29 to 40, write your answers in the spaces provided. The number of marks available is shown in brackets [] at the end of each question or part question.

[28 marks]

- 29 Two objects, A and H, made of different materials were placed on a **balance** as shown below.

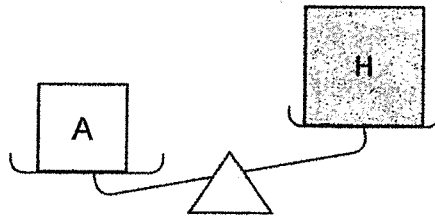

What could be concluded based on the above set-up using the balance?
Circle the correct answers for (a).

- (a) The **mass** / **volume** of the Object A is [1]

greater than / **the same as** / **smaller than** Object H. [1]

- (b) Then, the two objects were placed into two identical beakers, P and Q, containing the same amount of water as shown below.

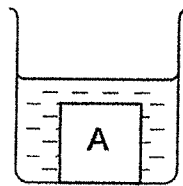

Beaker P

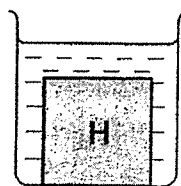

Beaker Q

Why is the water level in beaker Q higher than the water level in beaker P? [1]

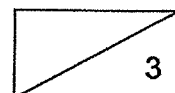

30 The diagram below shows the human digestive system.

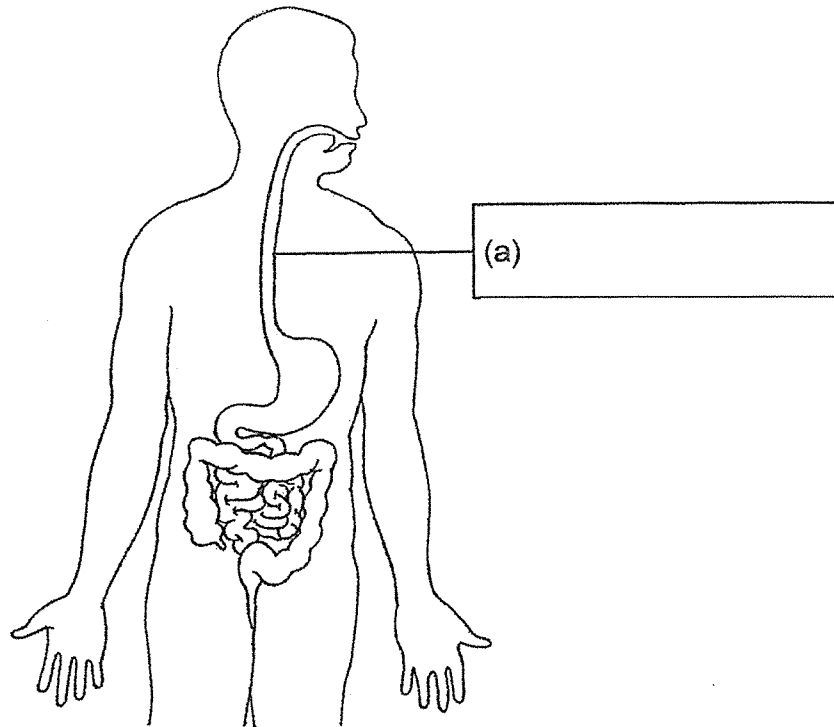

- (a) Name the organ in (a) by writing your answer in the box above. [1]
- (b) Name another organ where digestion does not take place. [1]

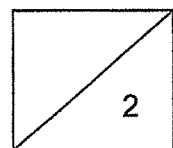

(Go on to the next page)

31 Study the life cycle of the butterfly and frog as shown below.

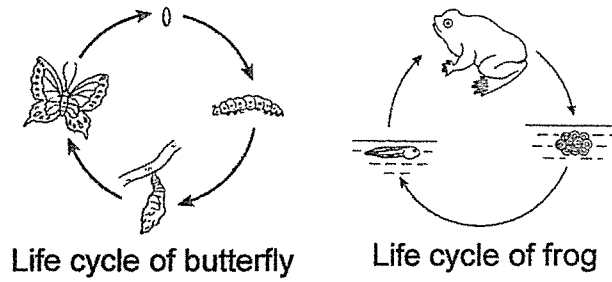

(a) Siti placed a caterpillar into a tank filled with leaves. She left the caterpillar in the tank until it developed into a butterfly. She measured the mass of leaves left in the tank and recorded her results as shown in the graph below.

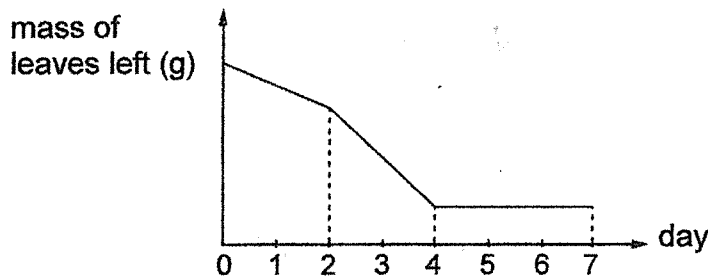

When did the caterpillar turned into a pupa? Explain your answer clearly. [2]

(b) It had not been raining for many months and the pond in Siti's garden was drying up. Siti noticed that there were fewer frogs in the pond. Based on the life cycle of frog given above, give a reason for Siti's observation. [1]

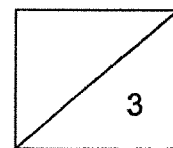

(Go on to the next page)

- 32 Bala conducted an experiment as shown below to find out if the amount of light affects the growth of seeds. He placed one of the set-ups in the open field and the other in the kitchen.

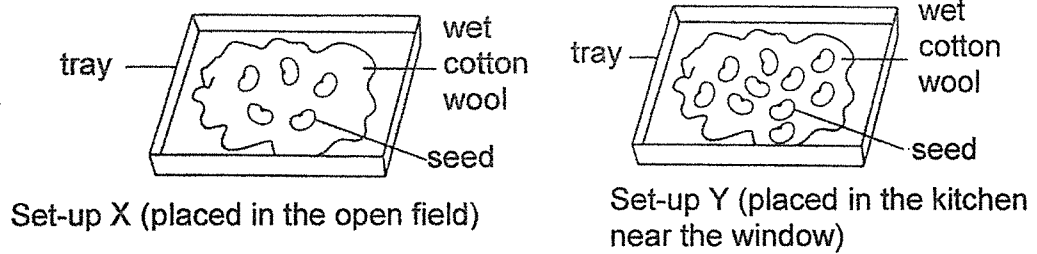

Bala's sister told him that his experiment was not fair. Suggest two changes that Bala should make to set-up Y so that the experiment is fair. [2]

Suggestion 1: _____

Suggestion 2: _____

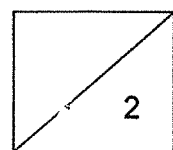

(Go on to the next page)

- 33 Wenli filled a beaker with water to the brim as shown in the diagram below. She then dropped a steel ball into the beaker.

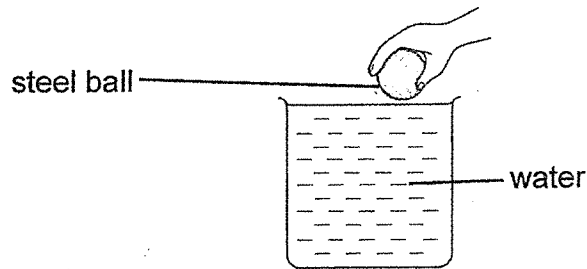

- (a) What property of matter was shown in the experiment above? [1]

Wenli transferred a Matter Z from the measuring cylinder to a beaker as shown below and she observed the following result.

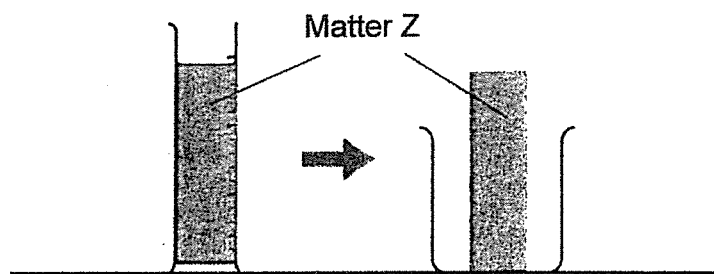

- (b) What is the state of Matter Z? Explain your answer. [2]

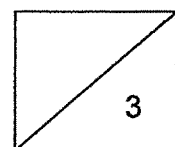

(Go on to the next page)

34 The diagram below shows an oven.

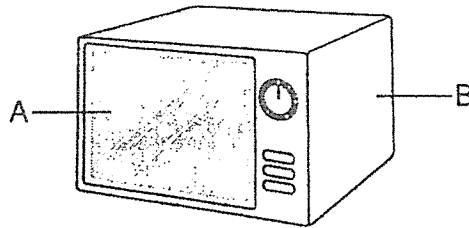

- (a) Part A is made of glass because it allows _____ to pass through so that the user can see the dish inside. [1]
- (b) Part B is made of _____ because it needs to be strong. [1]

35 Bala used an instrument to measure the temperature of water in a beaker.

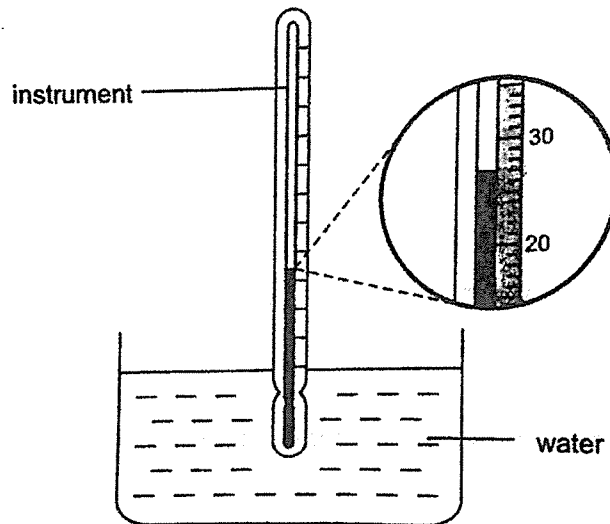

- (a) What is the instrument called? [1]

- (b) What is the temperature of the water in the beaker? [1]

_____ °C

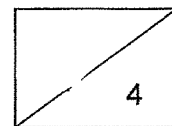

(Go on to the next page)

36 The diagram below shows how a person sees the flower.

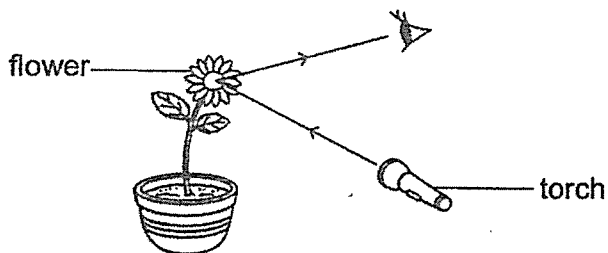

The _____ from the torch is _____ by the flower and enters the person's eye. [2]

37 Janet took out two glasses, P and Q, from her cupboard and she found that the glasses were stuck together.

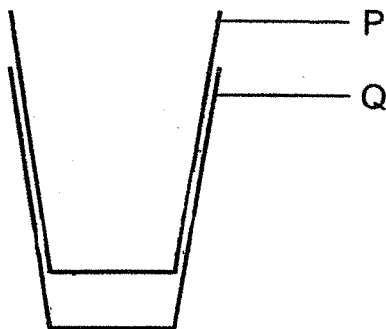

Janet decided to pour hot water on glass P to separate them but it did not work. Explain why. [2]

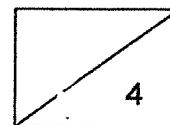

(Go on to the next page)

- 38 An experiment was set up as shown below. One ice cube of equal volume was placed in container X, Y and Z at room temperature. Container X, Y and Z are made of different materials.

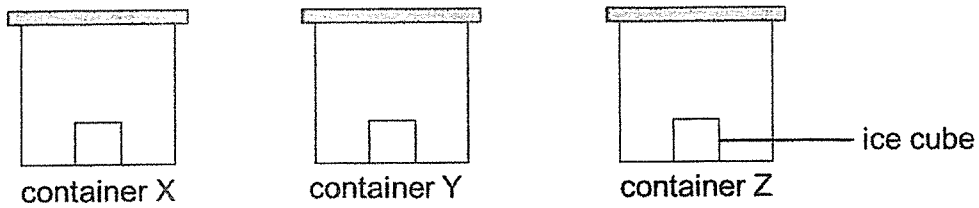

After 30 minutes, the ice cubes were removed from each container. The amount of water collected in each container was measured. The results are shown in the graph below.



- (a) Which container, X, Y or Z caused the ice cubes to melt the slowest? Explain your answer based on the graph above. [1]

- (b) What property of the container you have chosen in (a) caused the ice cube to melt the slowest? [1]

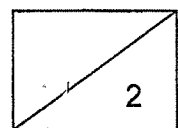

(Go on to the next page)

- 39 The diagram below shows a set up to measure the amount of light that could pass through different materials, R, S and T.

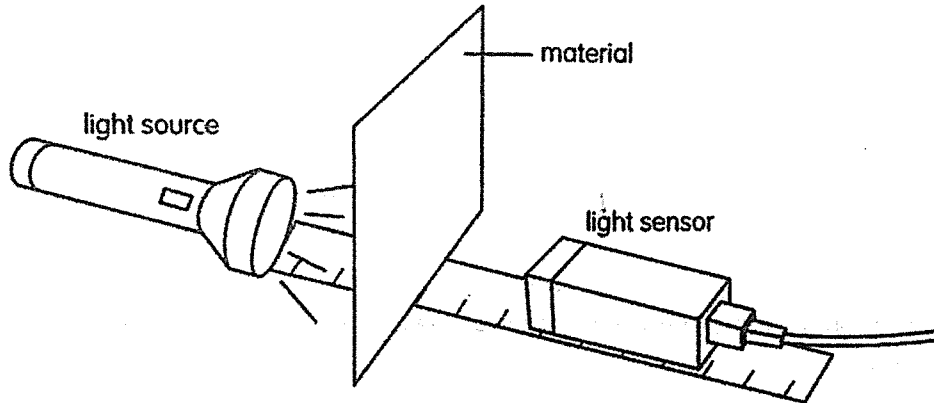

The table below shows the amount of light that passed through different materials, R, S and T.

| Material | Amount of light (units) |
|-------------|-------------------------|
| no material | 100 |
| R | 0 |
| S | 60 |
| T | 98 |

The picture below shows a pair of sunglasses.

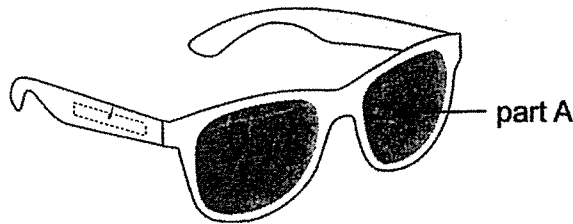

- (a) Based on the results, which material R, S or T, would be suitable to make Part A of the sunglasses? [1]

Material _____

- (b) Explain your answer based on the results above. [1]

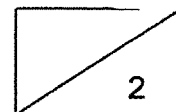

(Go on to the next page)

40 Roy prepared an electromagnet set-up as shown below.

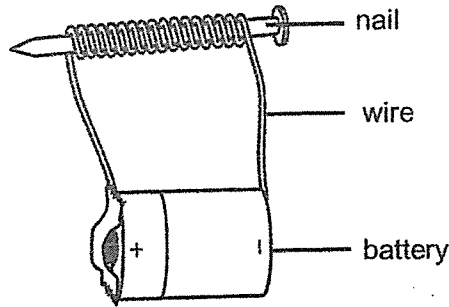

He used nails made of different types of materials, A, B and C, to find out how many pins they could attract. The results are shown below.

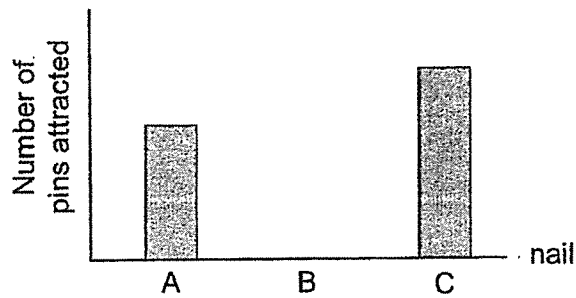

(a) Which nail, A, B or C, should Roy choose if he wanted to make a stronger electromagnet? Explain your answer. [1]

(b) What could nail B be made of? Explain your answer. [2]

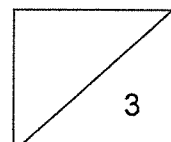

ANSWER KEY

YEAR : 2022
LEVEL : Primary 4
SCHOOL : Methodist Girls' School
SUBJECT : SCIENCE
TERM : Timed Practice Paper

BOOKLET A

| | | | | | | | | | |
|-----|---|-----|---|-----|---|-----|---|-----|---|
| Q1 | 2 | Q2 | 3 | Q3 | 3 | Q4 | 2 | Q5 | 1 |
| Q6 | 2 | Q7 | 2 | Q8 | 2 | Q9 | 2 | Q10 | 4 |
| Q11 | 1 | Q12 | 1 | Q13 | 1 | Q14 | 3 | Q15 | 3 |
| Q16 | 1 | Q17 | 2 | Q18 | 1 | Q19 | 3 | Q20 | 3 |
| Q21 | 4 | Q22 | 3 | Q23 | 2 | Q24 | 2 | Q25 | 3 |
| Q26 | 2 | | | | | | | | |

BOOKLET B

| | |
|-----|---|
| Q29 | (a) mass greater than (b) Object H has a larger volume than object A. |
| Q30 | (a) gullet (b) large intestine |
| Q31 | (a) Day 4. The mass of leaves left stayed the same for days 4-7, and the pupa does not feed, therefore, the caterpillar turned into a pupa on day 4. (b) The frog lays eggs in the water and the eggs hatch in water, if the pond dried up, the adult frogs could not lay the eggs, causing the number of frogs in the pond to decrease. |
| Q32 | (a) Suggestion 1 : Make the number of seeds on the cotton wool equal. Suggestion 2 : Place set-up Y in a dark cupboard. |
| Q33 | (a) Matter occupies space (b) Solid. It cannot take the shape of the container and thus having a definite shape hence solid. |
| Q34 | (a) most light (b) metal |
| Q35 | (a) thermometer (b) 27°C |
| Q36 | light, reflected |
| Q37 | Glass P gained heat from the hot water and expanded, thus increasing in volume. |

| | |
|-----|---|
| Q38 | (a) Container Y. It collected the least amount of water. (b) Poor heat conductivity |
| Q39 | (a) Material S (b) Material S only allows some light to pass through thus it is good for reducing the amount of sunlight going into the users eyes. |
| Q40 | (a) Nail C. It attracted the most number of pins and therefore has the strongest magnetism. (b) Aluminium. Aluminium is made of a non-magnetic material and it cannot be magnetised thus not able to attract the pins hence B is made up of aluminium. |

2
END