



## 2022 PRIMARY 4 MID-YEAR EXAMINATION

Name : \_\_\_\_\_ ( )

Date: 12 May 2022

Class : Primary 4 ( )

Time: 8.00 a.m. - 9.30 a.m.

Parent's Signature: \_\_\_\_\_

Duration: 1 hour 30 minutes

# SCIENCE

## BOOKLET A

### INSTRUCTIONS TO CANDIDATES

1. Write your name, class and register number.
2. Do not turn over this page until you are told to do so.
3. Follow all instructions carefully.
4. Answer all questions.
5. Shade your answers on the Optical Answer Sheet (OAS) provided.



**Booklet A (22 x 2 marks)**

For each question from 1 to 22, four options are given. One of them is the correct answer. Make your choice (1, 2, 3 or 4) and shade your answer on the Optical Answer Sheet.

(44 marks)

1. The diagram below shows the life cycle of animal X.

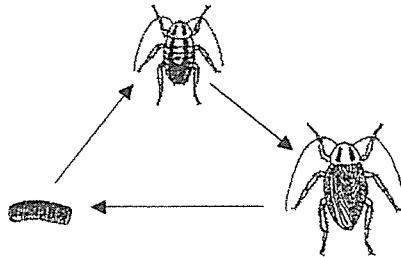

Which statement can be concluded based on the diagram above?

- (1) Animal X has a 3-stage life cycle.
  - (2) Animal X has all its stages in water.
  - (3) The young of animal X does not feed.
  - (4) The young of animal X does not look like the adult.
2. Study the diagram below.

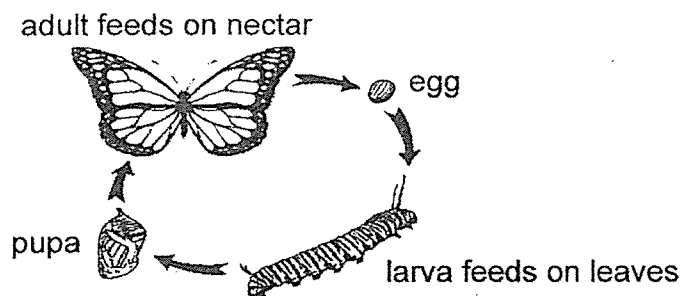

Which stage of the life cycle of the above butterfly would cause a problem to farmers growing vegetables?

- (1) egg
- (2) larva
- (3) pupa
- (4) adult

3. Study the flow chart below.

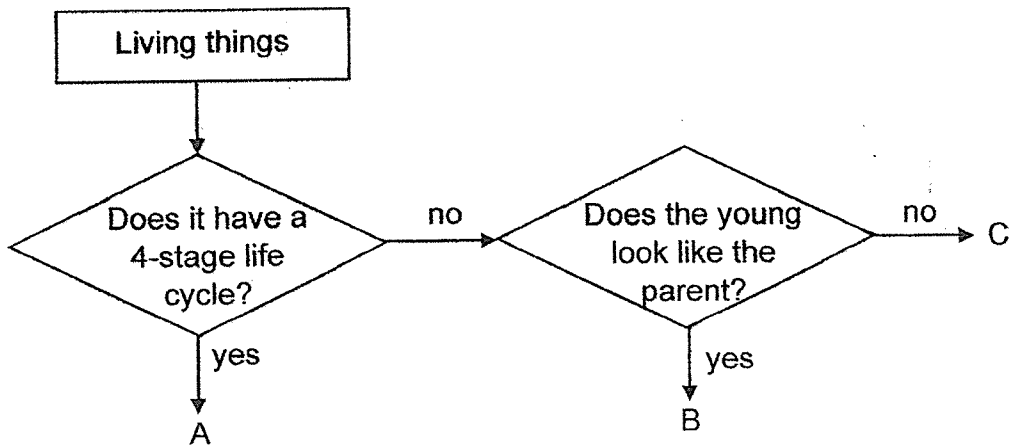

Which one of the followings represents living things, A, B and C?

	A	B	C
(1)	mealworm beetle	chicken	frog
(2)	mosquito	frog	chicken
(3)	frog	mosquito	mealworm beetle
(4)	chicken	frog	mosquito

4. Study the classification chart and the three living things, A, B and C.

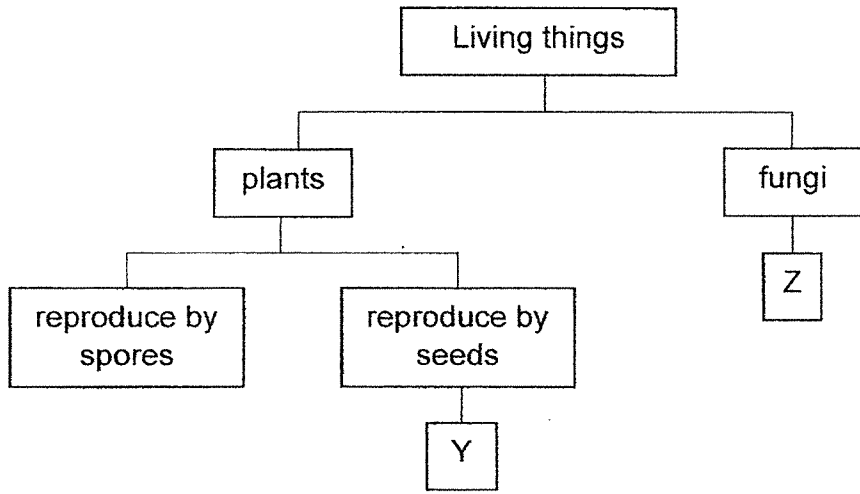
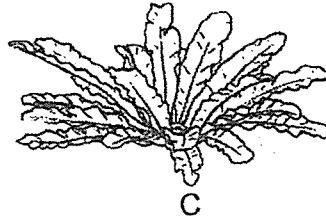

Which of the following shows the correct classification of the living things in boxes Y and Z?

	Y	Z
(1)	B	C
(2)	C	B
(3)	A	B
(4)	A	C

5. The diagram below shows the digestive system of a human.

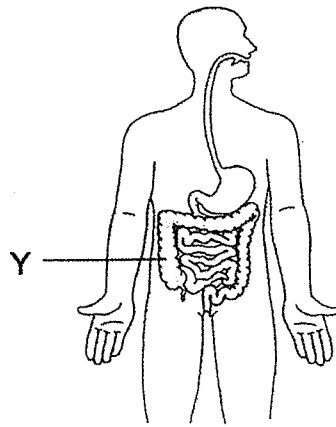

What is the function of part Y?

- (1) digests food
  - (2) absorbs water
  - (3) absorbs digested food
  - (4) produces digestive juice
6. The diagrams below show two plants, A and B.

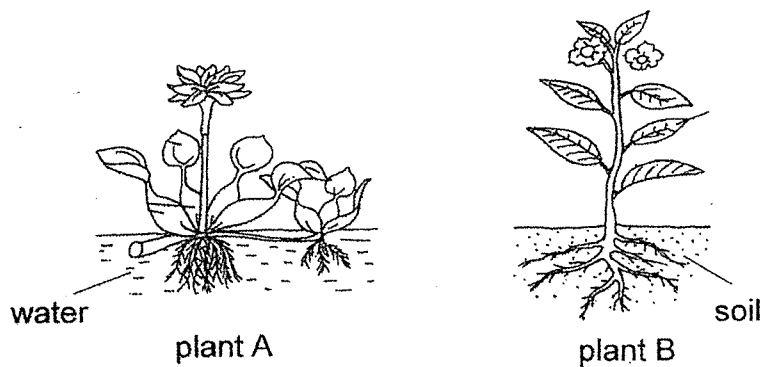

Plant A lives in water and plant B lives on land.

Which of the following is a similar function of the roots of both plants A and B?

- (1) makes food for plants A and B
- (2) holds plants A and B firmly to the soil
- (3) holds plants A and B upright
- (4) takes in water and minerals for plants A and B

7. Plant T is a living thing that uses its leaves to catch insects. Its leaf will close when an insect walks onto it as shown in the diagram below.

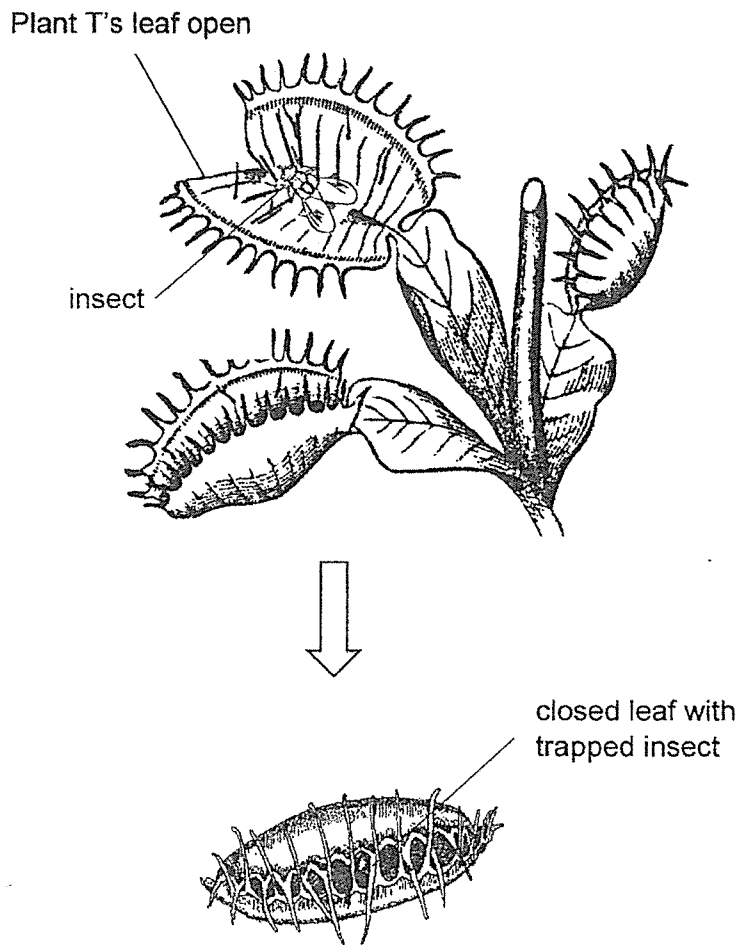

The closed leaf can carry out the two processes, digestion and absorption.

Which organ, in the human digestive system, has similar functions as the closed leaf of plant T?

- (1) mouth
- (2) gullet
- (3) stomach
- (4) small intestine

8. The diagram below shows a tool the mountaineers use during their attempts to climb mountains.

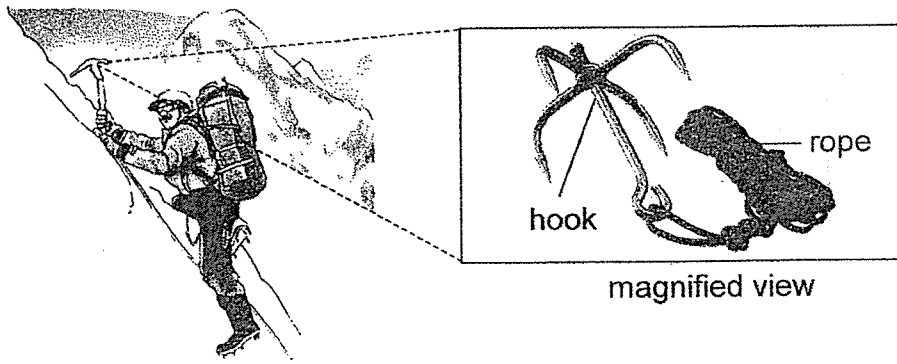

Which of the following shows the properties of the materials of the hook and rope necessary for the use shown above?

	hook	rope
(1)	strong	flexible
(2)	strong	can float
(3)	flexible	flexible
(4)	flexible	can float



9. The diagram below shows a container with some water in it.

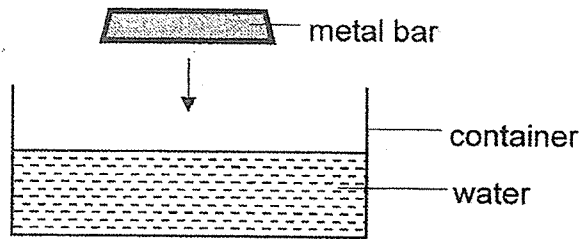

What will happen to the water level and the volume of water in the container when a metal bar is placed gently into the container of water?

	water level in the container	volume of water in the container
(1)	decrease	remain the same
(2)	decrease	increase
(3)	increase	increase
(4)	increase	remain the same

10. Study the substances, C and D, in the table below.

substance	has a definite shape	has a definite volume
C	✓	✓
D		✓

Which of the following about substances C and D are correct?

	substance C	substance D
(1)	is a gas	is a liquid
(2)	is a solid	is a liquid
(3)	cannot be compressed	can be compressed
(4)	takes the shape of a container	does not take the shape of a container

11. The diagram below shows three substances, X, Y and Z, in three identical containers.

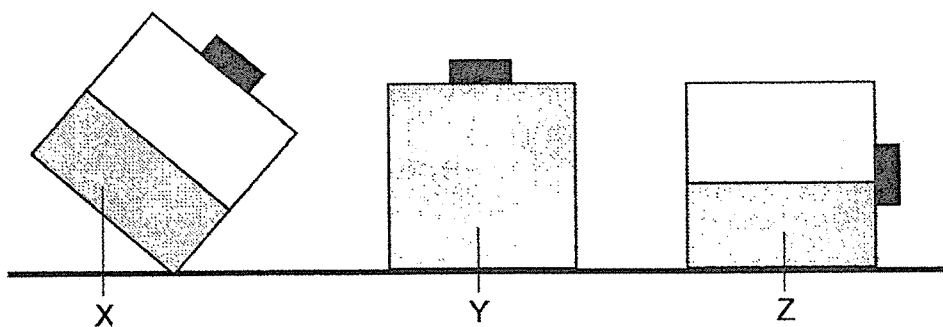

Based on the diagram above, which of the sentence(s) is/are definitely correct?

A: Substance X is a solid.

B: Substance Y is a liquid.

C: Substances Y and Z have definite shape.

(1) A only

(2) C only

(3) A and B only

(4) B and C only

12. The picture below shows an object Q.



object Q

Which of the following instruments can be used to measure the volume of object Q? (The apparatus are not drawn to scale)

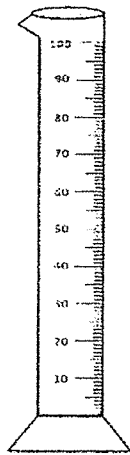

measuring cylinder  
(1)

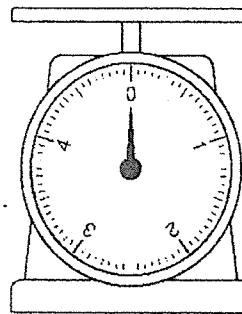

weighing scale  
(2)

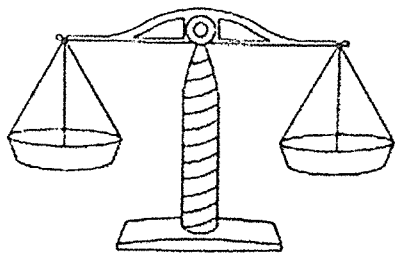

balance scale  
(3)



syringe  
(4)

13. Joshua pushed an inverted plastic cup into a container of water until the mouth of the plastic cup touched the bottom of the container. He pressed the cup firmly as shown in the diagram below.

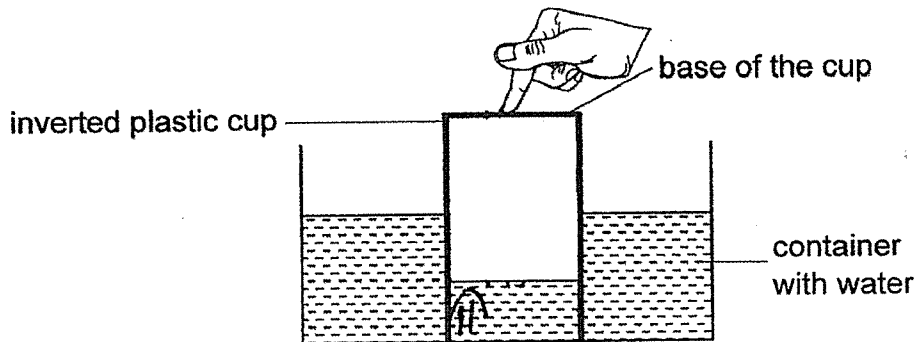

Then, Joshua poked a hole at the base of the cup. The water level in the cup rose slowly. What can Joshua do to make the water level rise **faster**?

- (1) Press the cup harder.
  - (2) Seal up the hole with a tape.
  - (3) Remove some water from the container.
  - (4) Make another hole at the base of the cup.
14. Jack filled the tyre of his bicycle wheel with air using a pump as shown below.

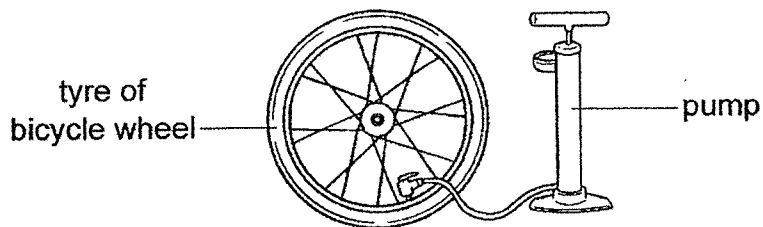

Even though the tyre looks inflated, Jack could pump in another four more pumps of air. Which properties of air allowed him to pump more air into the tyre?

- (1) Air has mass.
- (2) Air can be compressed.
- (3) Air has a definite shape.
- (4) Air has a definite volume.

15. Which of the following is a source of light?



fire  
(1)



glass bottle  
(2)

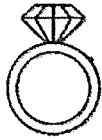

diamond ring  
(3)

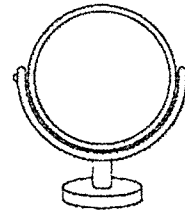

mirror  
(4)

16. Study the diagram below.

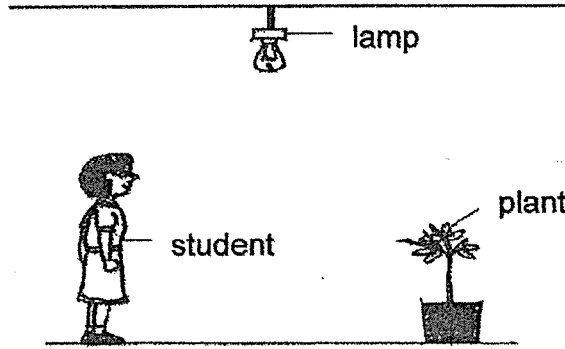

Which of the following shows the path of light that makes it possible for the student to see the plant when the lamp is switched on?

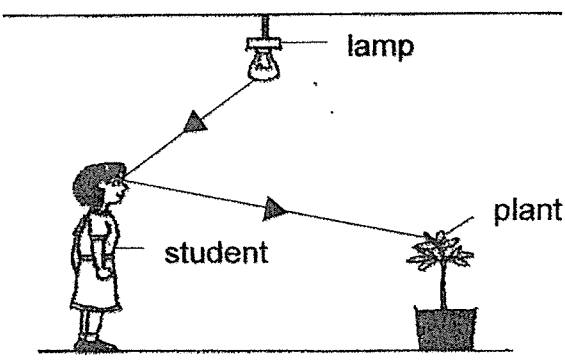

(1)

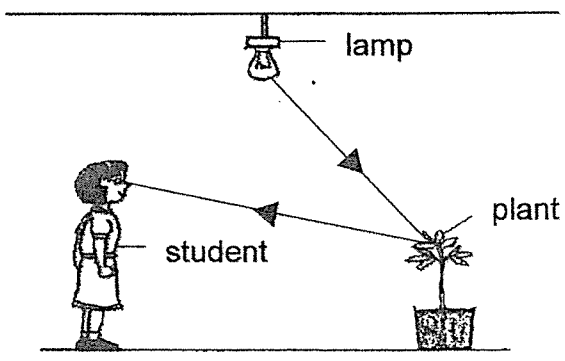

(2)

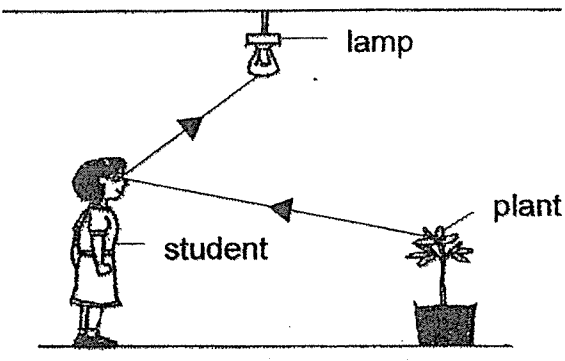

(3)

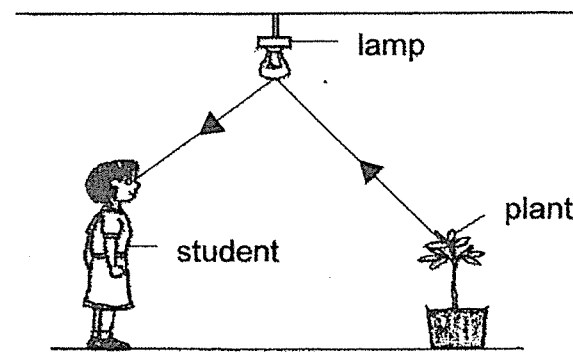

(4)

17. In a lit room, Jon tried to peep through a hole to look at the items on the other side of the wall as shown below.

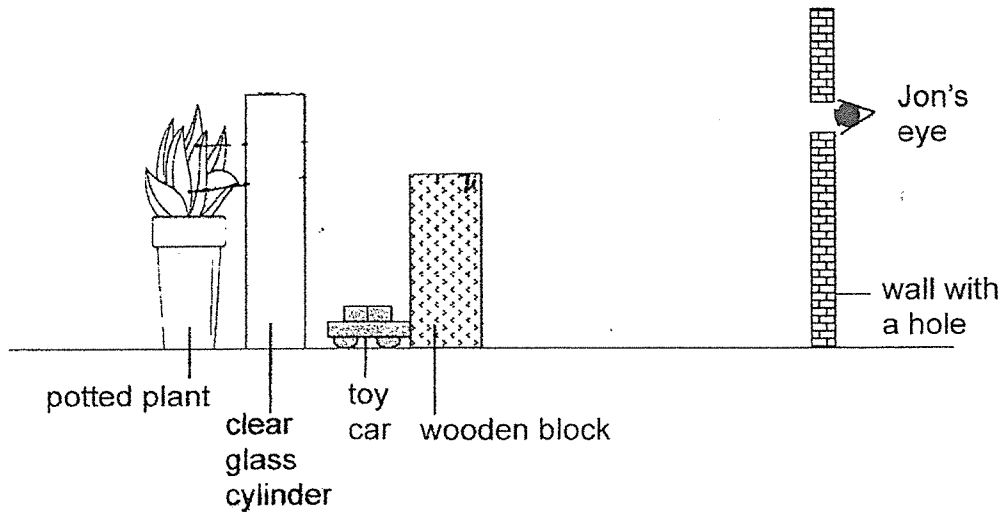

Besides the wooden block, what other item(s) could he see through the hole?

- (1) clear glass cylinder only
- (2) toy car and clear glass cylinder only
- (3) clear glass cylinder and potted plant only
- (4) toy car, clear glass cylinder and potted plant

18. A torch and three objects, X, Y and Z, of equal heights were arranged in a straight line in front of a whiteboard as shown below.

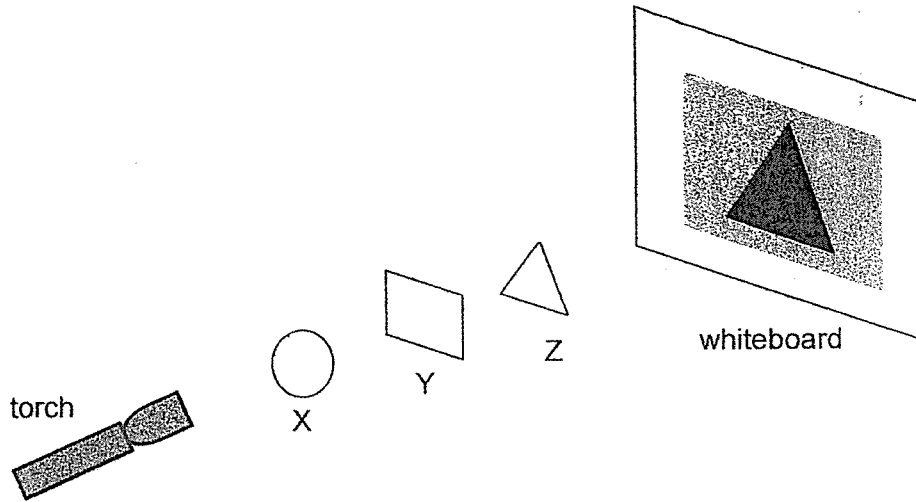

What property should objects X, Y and Z have in order to cast the shadow shown on the whiteboard?

	allows no light to pass through	allows some light to pass through	allows most light to pass through
(1)	X	Y	Z
(2)	X	Z	Y
(3)	Z	X	Y
(4)	Z	Y	X



19. The diagram below shows an experiment Jack conducted in a dark room.

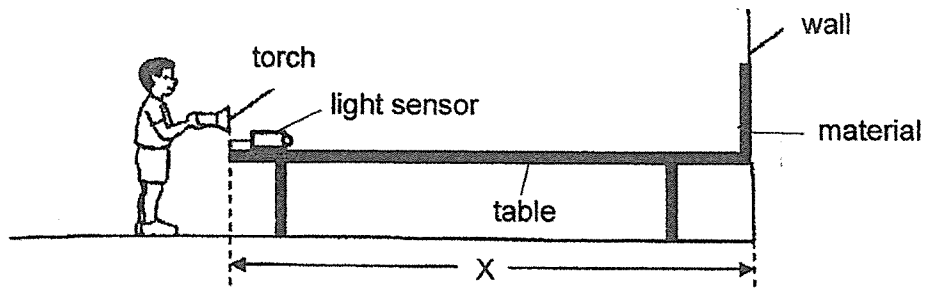

Jack wanted to find out which material, S, T, U and V, could reflect the most light. His results are shown below.

Material	S	T	U	V
light sensor reading (unit)	500	1000	1500	800

Traffic cones are used to block off the road at a road construction site as shown in the diagram below.

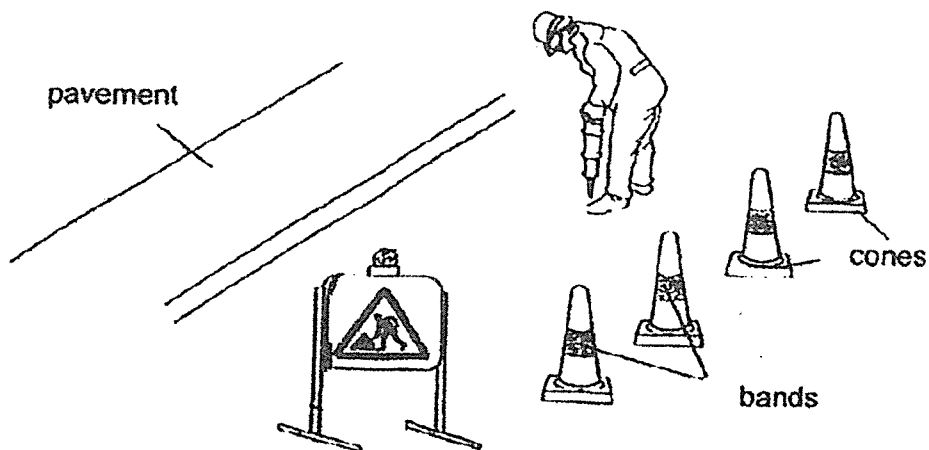

These cones have reflective bands to alert drivers of dangers from afar.

Based on Jack's results, which material should be used to make the reflective bands on the cones?

- (1) S
- (2) T
- (3) U
- (4) V

20. Xavier shone a torch at solid X which was placed at different positions as shown in diagrams A and B below.

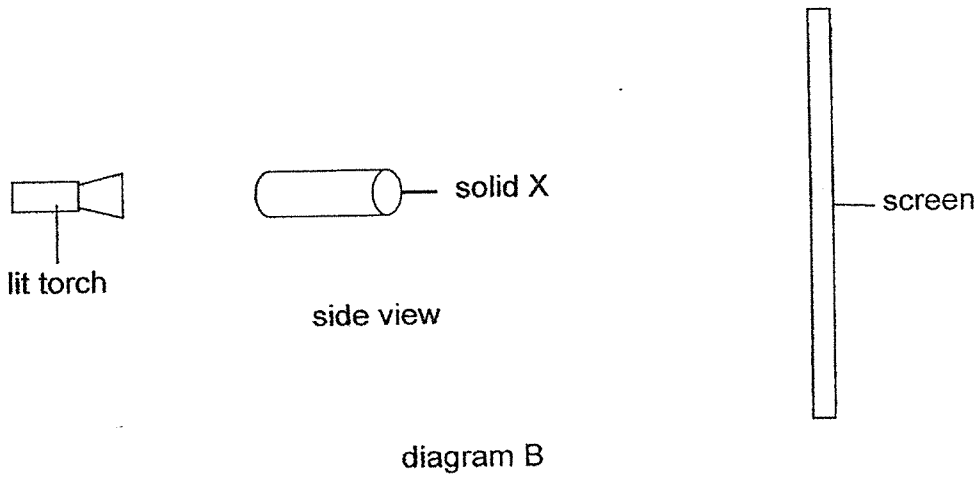
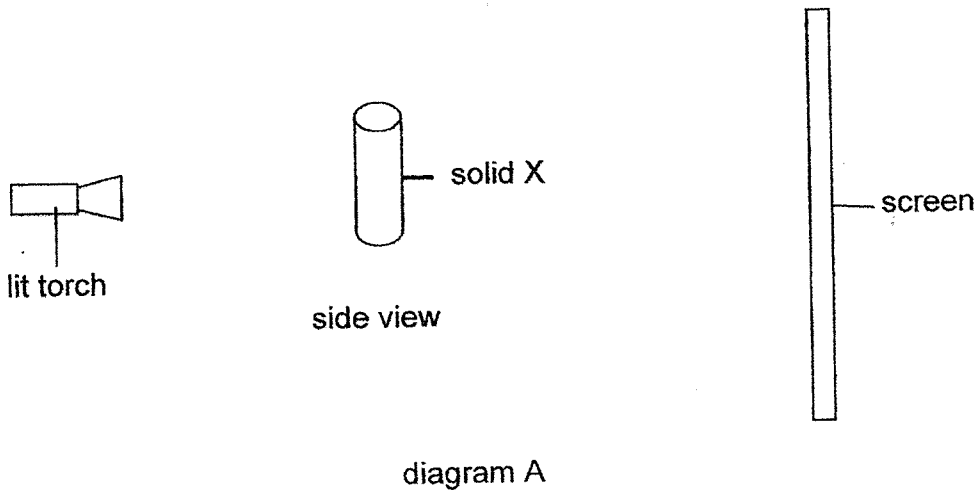

Which of the following shadows can be formed by solid X?

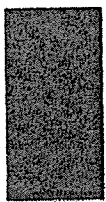

A



B

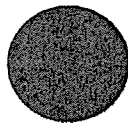

C



D

- (1) A and C
- (2) A and D
- (3) B and C
- (4) B and D

21. The diagram below shows an electromagnet.

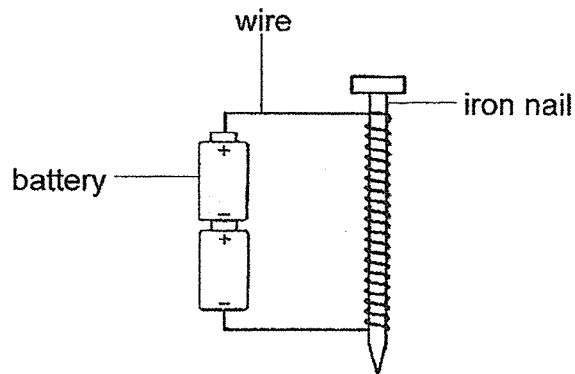

Which of the following can increase the strength of the electromagnet?

- (1) Use a longer nail.
- (2) Remove one battery.
- (3) Increase the number of turns of wire around the nail.
- (4) Increase the length of wire, keeping the number of turns around the nail the same.

22. Mr Tan carried out the following experiment to find out how the size of a magnet affects the number of pins it could attract.

The pins were distributed evenly on the tray.

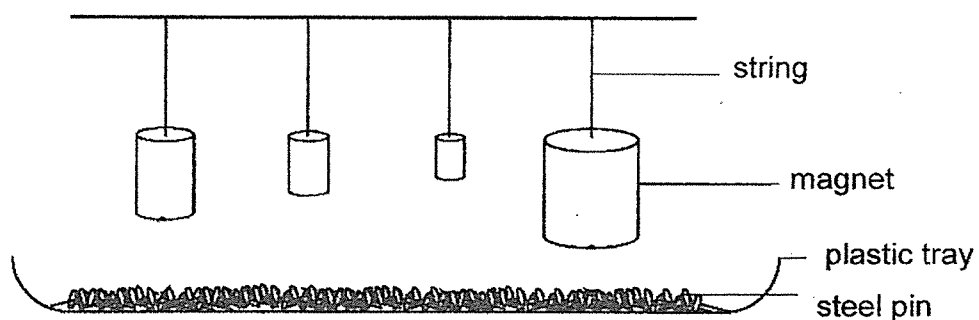

However, Mr Tan realised his experiment was unfair.

Which of the following variable should he have kept the same?

- (1) size of magnets
- (2) length of strings
- (3) number of steel pins attracted
- (4) distance between the base of the magnets and steel pins

End of Booklet A



## 2022 PRIMARY 4 MID-YEAR EXAMINATION

Name : \_\_\_\_\_ ( )

Date: 12 May 2022

Class : Primary 4 ( )

Time: 8.00 a.m. – 9.30 a.m.

Parent's Signature : \_\_\_\_\_

Duration: 1 hour 30 minutes

# SCIENCE

## BOOKLET B

### INSTRUCTIONS TO CANDIDATES

1. Write your name, class and register number.
2. Do not turn over this page until you are told to do so.
3. Follow all instructions carefully.
4. Answer all questions.
5. Write your answers in the booklet.

Booklet A	44
Booklet B	36
Total	80

**Booklet B (36 marks)**

For questions 23 to 34, write your answers clearly in this booklet.



The number of marks available is shown in brackets [ ] at the end of each question or part question.

(36 marks)

23. Jiayi indicated the characteristics of animals, P, Q, R and S, with a (✓) as shown in the table below.

Animals	has scales	has hair	has six legs	lives in water	lives on land
P	✓				✓
Q			✓		✓
R		✓			✓
S				✓	✓

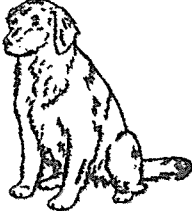
Use the information above to match against the animals in the table below. Fill in P, Q, R or S in the correct box. [2]

			
bee	dog	tree snake	frog

Score	2
-------	---

24. Peter wanted to find out if the amount of water affects the growth of bread mould. The table below shows the different types of bread which were placed under different conditions.

set-up	type of bread	amount of water sprinkled on the bread (ml)	location of bread
A	white bread	0	in the cupboard
B	wholemeal bread	5	in the cupboard
C	white bread	5	in the cupboard
D	white bread	10	in the freezer
E	wholemeal bread	10	in the freezer

- (a) Which two set-ups, A, B, C, D or E, should Peter use to conduct the experiment fairly? [1]

---

- (b) What should Peter be observing to make a conclusion on the experiment? [1]

---

---

- (c) Besides water, what else must be present for the mould to grow? [1]

---

Score	3
-------	---

25. The diagram below shows part of the life cycle of a mango plant.

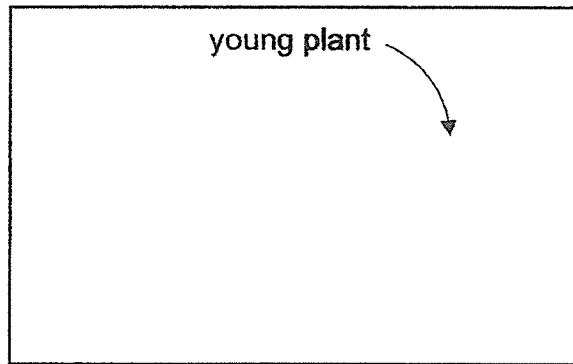

(a) Complete the life cycle of the mango plant above. [1]

(b) At which stage(s) of the life cycle of the mango plant can it make its own food? Explain why. [1]

---

---

The picture below shows a half-cut mango fruit.

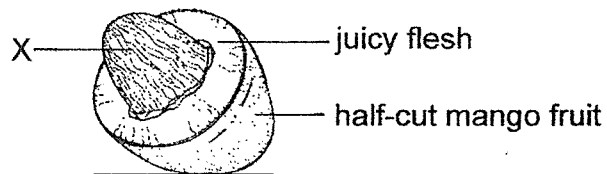

(c) Identify X and explain its function. [1]

---

---

Score	3
-------	---

26. Study the life cycle of the grasshopper and the frog as shown below.

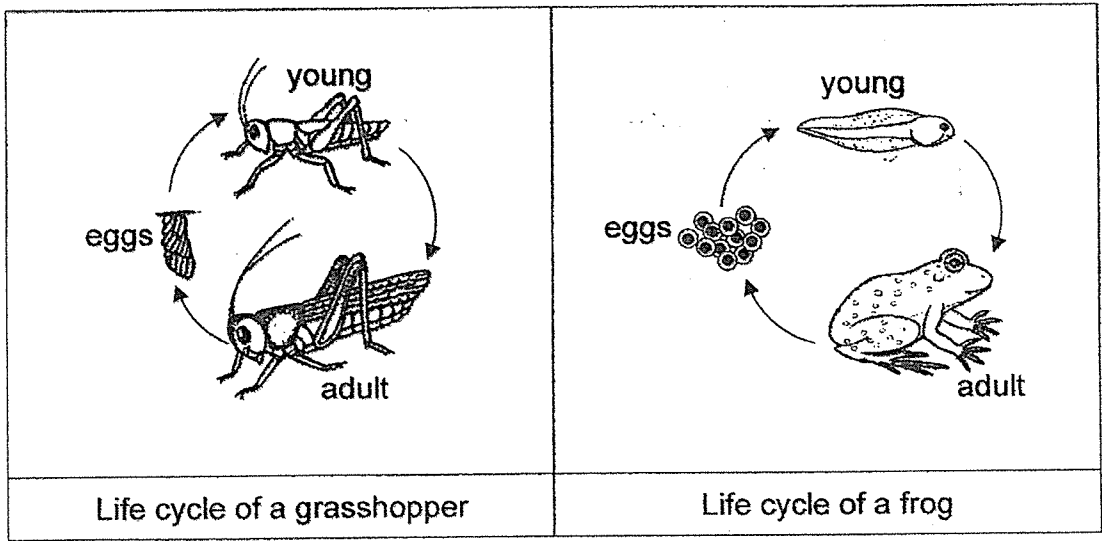

(a) State two similarities between the life cycle of the grasshopper and the frog. [2]

similarity 1: \_\_\_\_\_  
\_\_\_\_\_

similarity 2: \_\_\_\_\_  
\_\_\_\_\_

(b) State one difference between the life cycle of the grasshopper and the frog. [1]

\_\_\_\_\_  
\_\_\_\_\_

(c) What is the reason that the grasshoppers and the frogs both lay many eggs? [1]

\_\_\_\_\_  
\_\_\_\_\_

Score	4
-------	---



27. The diagram below shows the life cycle of a mosquito.

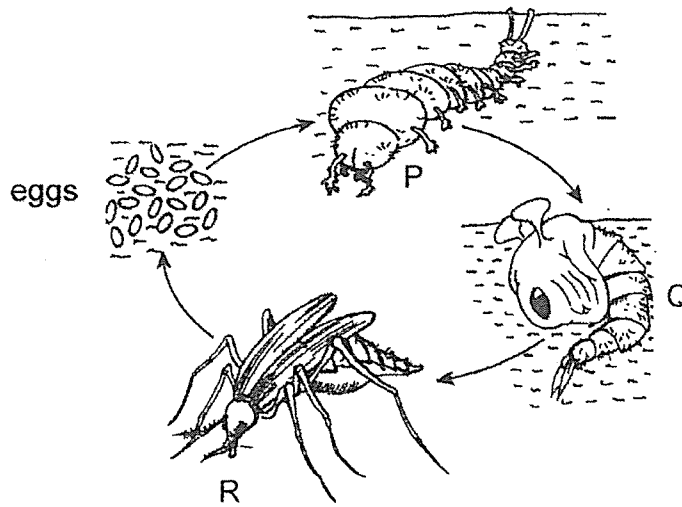

(a) State one difference between the characteristics of P and R. Do not compare the number of legs and their size. [1]

---

---

(b) Sammy noticed that there are mosquitoes breeding in the drain of his house. He poured a layer of oil over the water in the drain. Which stage(s), P, Q or R is/are Sammy trying to get rid of? [1]

---

Score	2
-------	---

Samy caught some Aedes mosquito larvae and observed them for 7 days. He provided the larvae with enough food and water to ensure their survival during his experiment. The bar graph below shows the number of larvae over the 7 days.

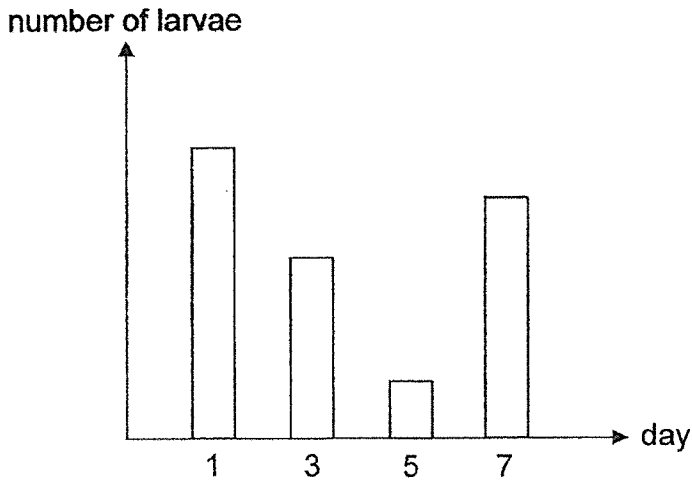

(c) Give a possible reason for the decrease in the number of mosquito larvae from day 1 to day 5, assuming that none of the larvae died during his experiment. [1]

---

---

(d) The number of mosquito larvae increased on day 7 even though Samy did not add any larvae to his experiment. Give a possible reason for the increase. [1]

---

---

Score	2
-------	---

28. The diagram below shows a plant that is watered daily.

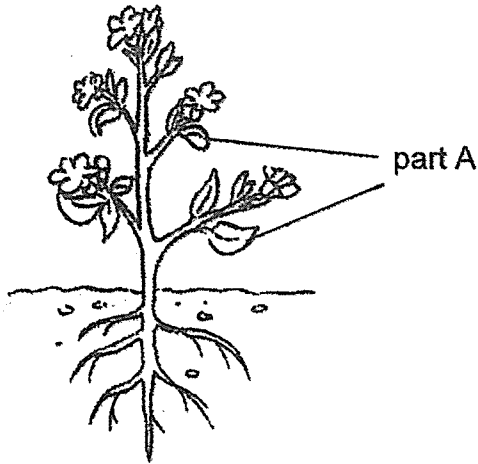

(a) Identify part A: \_\_\_\_\_ [1]

Later, many caterpillars were found on the plant. They ate up part A of the plant and the plant soon died.

(b) Explain why without part A, the plant would die. [1]

---

---

Score	2
-------	---

29. Thomas poured some oil into a glass bottle using a funnel as shown in the diagram below.

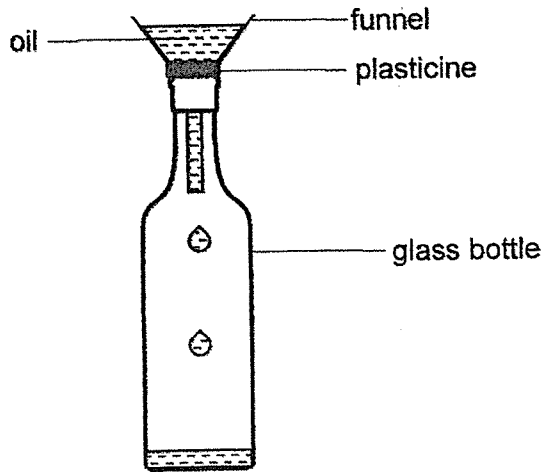

(a) Thomas noticed that the oil flowed into the glass bottle very slowly and then stopped flowing after some time. Explain why the oil stopped flowing. [2]

---

---

---

(b) Without using additional apparatus and without damaging the glass bottle, what could Thomas do to make the oil flow faster into the glass bottle? [1]

---

---

Score	3
-------	---

30. June tied a deflated balloon to one end of a straw as shown in the diagram below.

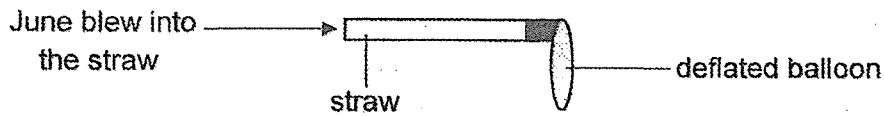

(a) What would happen to the balloon when June blew into the straw? [1]

---



---

June then inserted the straw with the deflated balloon into a jar filled with air as shown in Setup A and she tried to blow into the straw. She repeated the same steps in the jar filled with water as shown in Setup B.

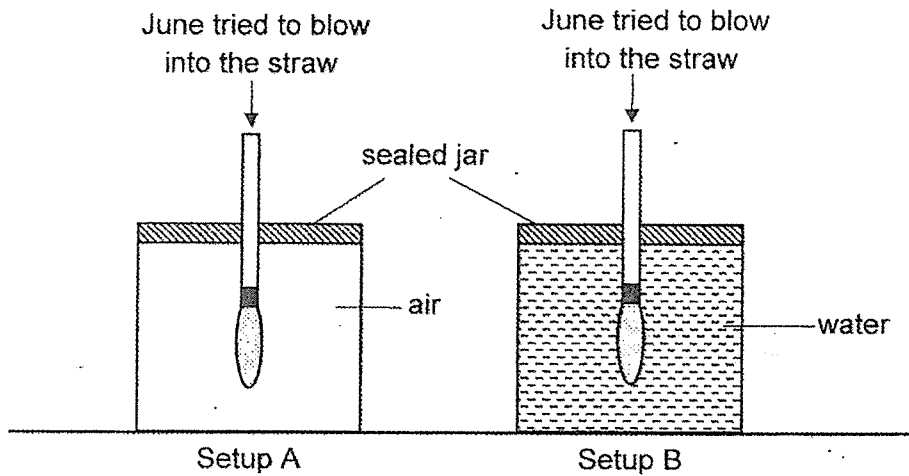

(b) What is the difference in the size of the balloon between setup A and B? [1]

---

(c) Explain the difference you have stated in (b).

[2]

---



---



---

31. Joyce placed four objects on the floor in a dark room.

The diagrams below show the observations made when the same light source was shone on the objects E, F, G and H.

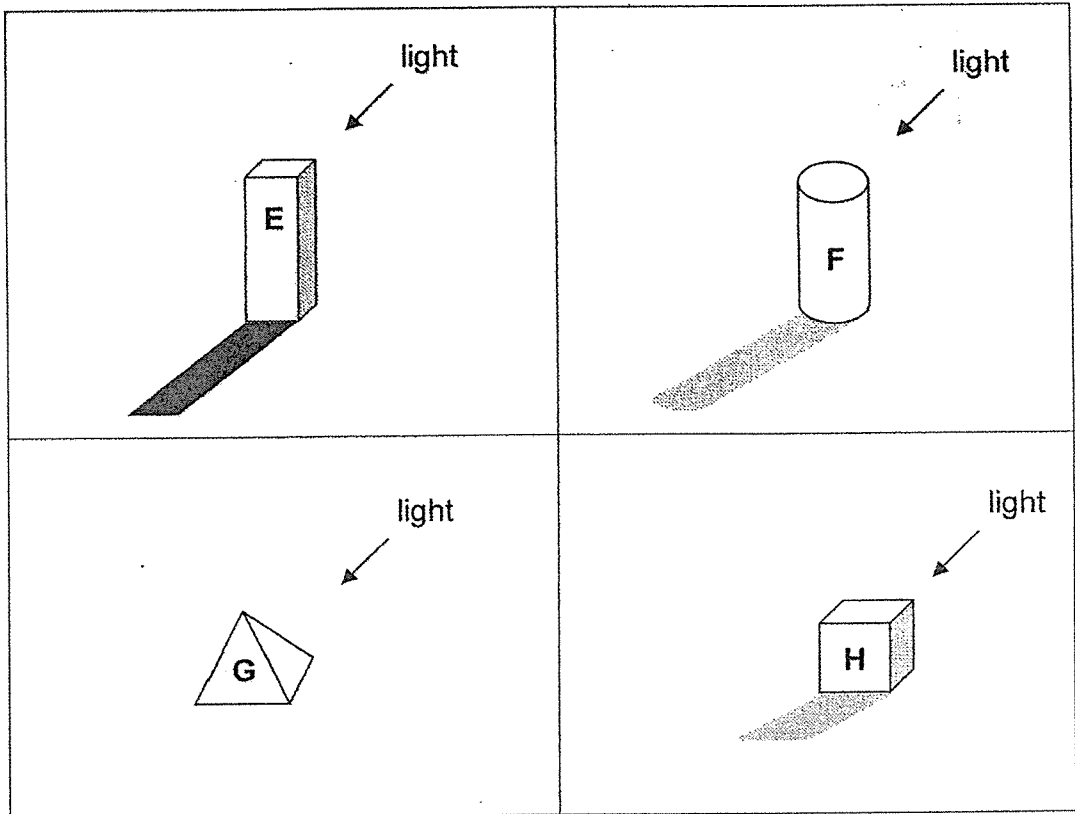

Based on the observations made, classify objects E, F, G and H, and write them under the correct headings in the table below. [2]

allows most light to pass through	allows some light to pass through	allows no light to pass through

Score	2
-------	---

32. Cecilia wanted to investigate how the positions of the lit lamp and Max affect the size of the shadow formed on the screen.

She conducted her experiment as shown below and outlined Max's shadow.

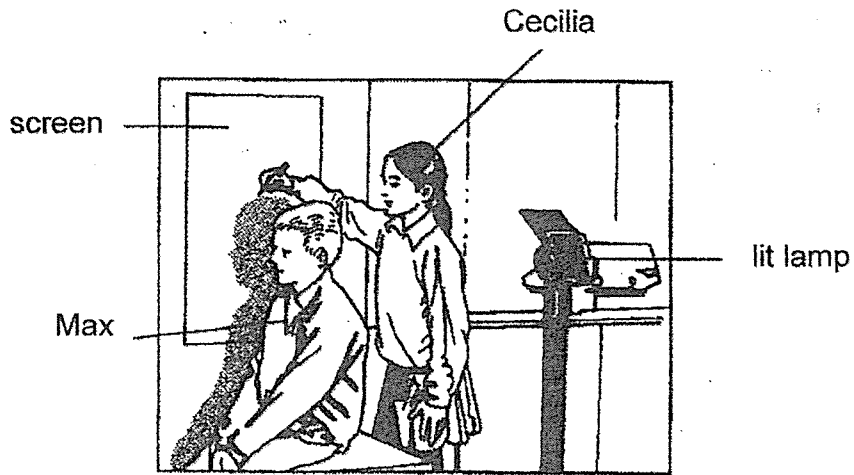

Without moving the screen, suggest two ways for Cecilia to get a bigger shadow of Max. [2]

(i) \_\_\_\_\_  
\_\_\_\_\_

(ii) \_\_\_\_\_  
\_\_\_\_\_

Score	2
-------	---

33. Raja released car P, made of iron, at A on a wooden ramp with object Z attached to the underside of the wooden ramp. His observation is shown below.

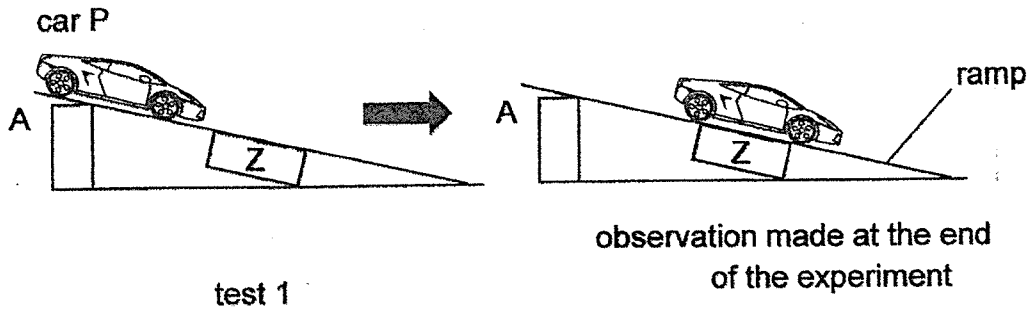

- (a) (i) Based on the observation made, what could object Z be? [1]

---

- (ii) Explain why car P stopped above object Z, [1]

---



---

Raja replaced car P with car Q and released it on the same wooden ramp. His observation is shown below.

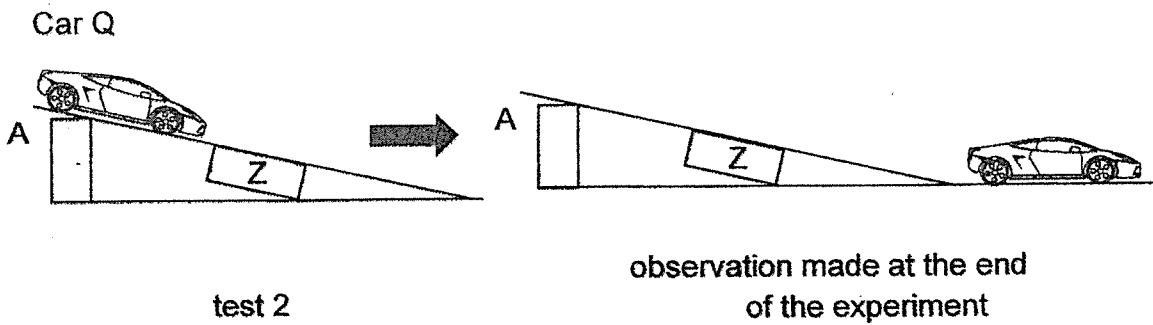

- (b) State one material that car Q could be made of. [1]

---

Score	3
-------	---



34. Jill wanted to conduct an experiment to measure how the number of sheets of wrapping paper affects the amount of light passing through them.

She was given the following items as shown below.

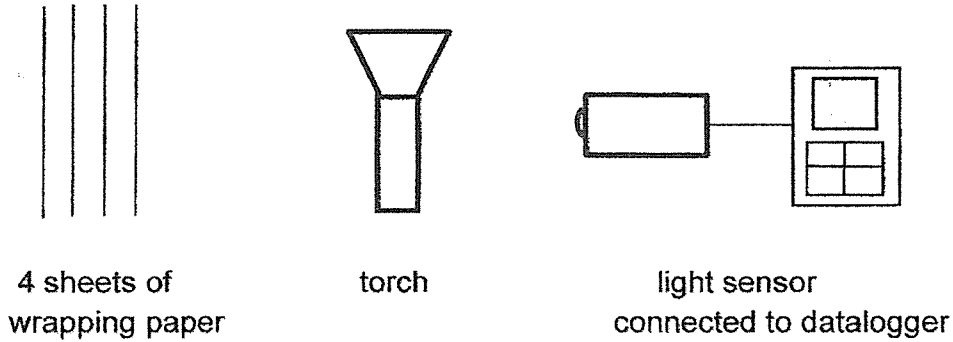

Listed below are steps A, B, C and D to be carried out in the experiment, but they are not in the correct order.

- A Shine the lit torch at the light sensor at a certain distance away.
- B Repeat the earlier steps using 2, 3, then 4 sheets of wrapping paper and record the results.
- C Measure the amount of light passing through the wrapping paper using the datalogger.
- D Place a sheet of wrapping paper between the torch and the light sensor.

(a) What is the correct order of the steps she should take to carry out her experiment? Write down A, B, C and D in the boxes below. [1]

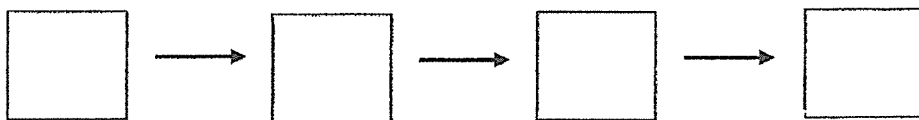

(b) State two variables which must be kept constant for the experiment to be a fair test. [2]

- (i) \_\_\_\_\_
- (ii) \_\_\_\_\_

Score	3
-------	---

After conducting the experiment, the table below shows the results that she obtained.

Number of sheets of wrapping paper	Amount of light (unit)
0	80
1	50
2	20
3	0
4	0

(c) Besides making changes to the wrapping paper, suggest another change to the set-up that could allow light to pass through 4 sheets of wrapping paper.

[1]

---

---

End of paper

Score	1
-------	---

YEAR : 2022  
LEVEL : PRIMARY 4  
SCHOOL : TAO NAN SCHOOL  
SUBJECT : SCIENCE  
TERM : MID YEAR EXAMINATION

(BOOKLET A)

Q1	1	Q2	2	Q3	1	Q4	3	Q5	2
Q6	4	Q7	4	Q8	1	Q9	4	Q10	2
Q11	1	Q12	1	Q13	4	Q14	2	Q15	1
Q16	2	Q17	3	Q18	4	Q19	3	Q20	1
Q21	3	Q22	4						

More Papers at [sgTestPaper.com](http://sgTestPaper.com)



**2022 P4 Science MYE (Suggested Answer for Students)**

**Booklet B**

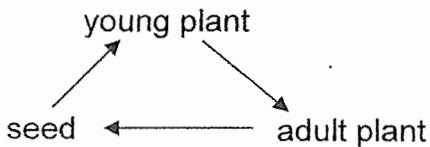
Qn	Suggested Answer											
23	<table border="1"> <thead> <tr> <th data-bbox="188 432 547 477">Animals</th> <th data-bbox="547 432 898 477">Animal</th> </tr> </thead> <tbody> <tr> <td data-bbox="188 477 547 510">Q</td> <td data-bbox="547 477 898 510">bee</td> </tr> <tr> <td data-bbox="188 510 547 544">R</td> <td data-bbox="547 510 898 544">dog</td> </tr> <tr> <td data-bbox="188 544 547 577">P</td> <td data-bbox="547 544 898 577">tree snake</td> </tr> <tr> <td data-bbox="188 577 547 611">S</td> <td data-bbox="547 577 898 611">frog</td> </tr> </tbody> </table>	Animals	Animal	Q	bee	R	dog	P	tree snake	S	frog	
Animals	Animal											
Q	bee											
R	dog											
P	tree snake											
S	frog											
24a	Bread A and C											
b	He should be observing for the presence/amount of mould.											
c	warmth, air											
25a	 <pre> graph TD     seed --&gt; young_plant[young plant]     young_plant --&gt; adult_plant[adult plant]     adult_plant --&gt; seed             </pre>											
b	Adult and young stage. The plant has leaves to make food.											
c	Seed. It helps the plant to reproduce.											
26a	Both have an egg stage / a young stage / an adult stage. Both are a 3-stage life cycle.											
b	The young of a frog does not resembles the adult but the young of the grasshopper resembles the adult.											
c	To increase the chance of the eggs <b>hatching / growing into adult</b> .											
27a	The pupa lives in the water but the adult mosquito lives on land. The adult mosquito have wings but the pupa does not.											
b	P and Q											
c	Most/Some of the larvae have turned into pupae or/and adult.											
d	The adult mosquitos reproduced.											
28a	Leaves											

b	Without leaves/Part A, the plant would not be able to make food/ carry out gaseous exchange.								
29a	The air <u>in the bottle</u> occupies space (cause) and could not be compressed any further (effect).								
b	Lift the funnel higher.								
30a	The balloon would be inflated.								
b	The size of the balloon in setup B is smaller.								
c	In setup A, air can enter the balloon because the air <u>in the jar</u> can be compressed.  In setup B, the air cannot enter the balloon because the water has a definite volume and so cannot be compressed.								
31	<table border="1"> <tr> <td><b>allows most light to pass through</b></td> <td><b>allows some light to pass through</b></td> <td><b>allows no light to pass through</b></td> </tr> <tr> <td>G</td> <td>F &amp; H</td> <td>E</td> </tr> </table>	<b>allows most light to pass through</b>	<b>allows some light to pass through</b>	<b>allows no light to pass through</b>	G	F & H	E		
<b>allows most light to pass through</b>	<b>allows some light to pass through</b>	<b>allows no light to pass through</b>							
G	F & H	E							
32	Move the lamp nearer to Max/ the screen. (Moving light source) Move Max nearer to lamp/ Move Max further from the screen. (Moving object)								
33a(i)	Magnet								
(a)(ii)	Iron is a magnetic material. Hence, it can be attracted by the magnet, Z.								
b	Wood/ plastic/ ceramic								
34a	A, D, C, B      or      D, A, C, B								
b	<u>Some possible answers:</u> Distance between torch and wrapping paper/ wrapping paper and light sensor/ torch and light sensor. Intensity of light Thickness of wrapping paper								
c	Move the torch closer to the wrapping paper								