



CATHOLIC HIGH SCHOOL
MID-YEAR EXAMINATION (2022)
PRIMARY FOUR
SCIENCE
BOOKLET A

Name: _____ ()

Class: Primary 4 - _____

Date: 12 May 2022

24 questions

48 marks

Total Time for Booklets A and B: 1 hour 30 minutes

INSTRUCTIONS TO CANDIDATES

Do not turn over this page until you are told to do so.

Follow all instructions carefully.

Answer all questions.

Shade your answers in the Optical Answer Sheet (OAS) provided.

This booklet consists of 12 printed pages, excluding the cover page.

Booklet A (24 × 2 marks)

For each question from 1 to 24, four options are given. One of them is the correct answer. Make your choice (1, 2, 3 or 4). Shade your answer on the Optical Answer Sheet. (48 marks)

1 Which of the following is a non-living thing?

(1)

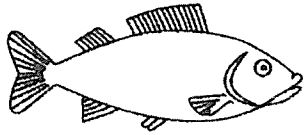

(2)

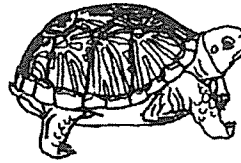

(3)

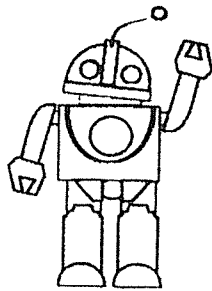

(4)



2 Which of the following is **not** a plant?

(1)



(2)

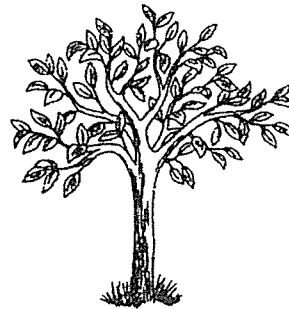

(3)



(4)



3 Which statements about yeast and bacteria are correct?

- A They are fungi.
- B They feed on living things, dead or alive.
- C A microscope is needed to see them clearly.

- (1) A and B only
- (2) A and C only
- (3) B and C only
- (4) A, B and C

4 Aaron used the set-ups below to study a certain property of material. He used straps made of different materials A and B and hung boxes of the same mass on them. The results are shown below.

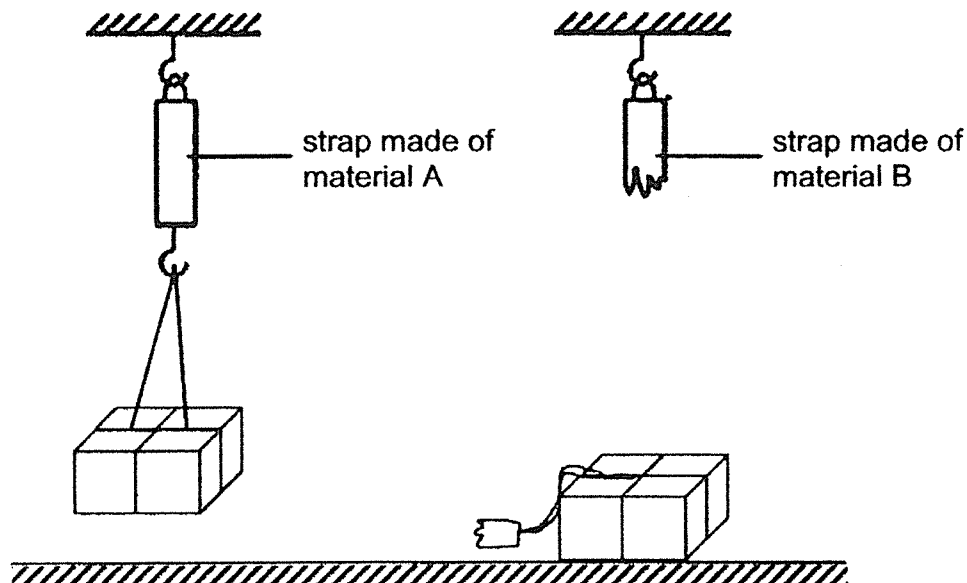

What can be concluded from the experiment?

- (1) Material A is stronger than material B.
- (2) Material B is stronger than material A.
- (3) Material A is more flexible than material B.
- (4) Material B is more flexible than material A.

5 Which statements about the respiratory system are correct?

- A The system takes in food and water into the body.
- B The system takes in and removes air from the body.
- C The system consists of the heart and blood vessels.
- D The system consists of the nose, windpipe and lungs.

- (1) A and C only
- (2) A and D only
- (3) B and C only
- (4) B and D only

6 The diagram below shows the function of different parts of a plant.

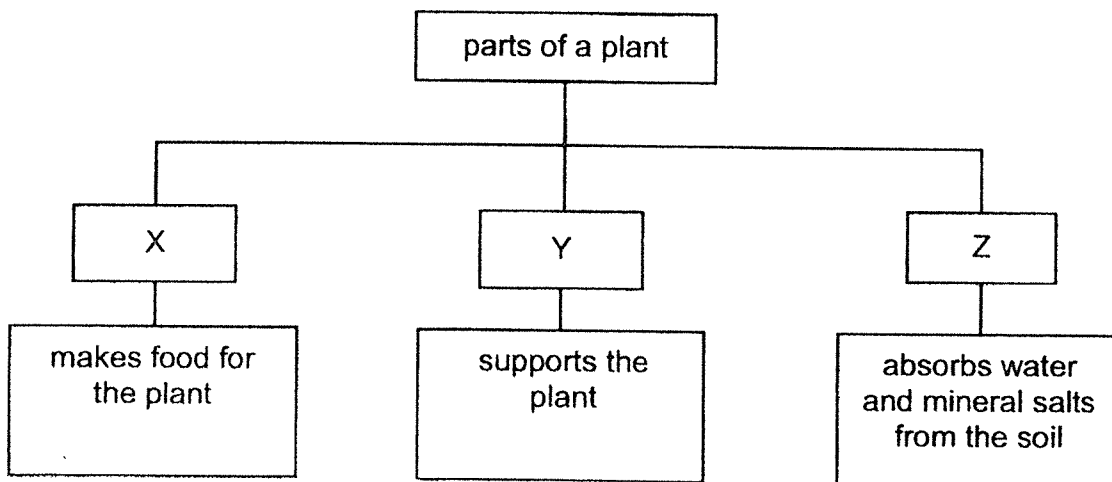

Which of the following correctly identifies parts X, Y and Z of the plant?

	X	Y	Z
(1)	leaf	stem	roots
(2)	stem	roots	leaf
(3)	roots	stem	leaf
(4)	leaf	roots	stem

- 7 The objects below are grouped based on whether they are attracted to a magnet.

Objects	
Group A	Group B
aluminium foil	steel rod

Which of the following correctly shows the objects placed in Group A and B?

	Group A	Group B
(1)	copper wire	plastic ring
(2)	copper wire	iron nail
(3)	iron nail	plastic ring
(4)	iron nail	copper wire

- 8 Balvan used a compass to locate the direction of the North pole and found the needle pointing in the direction as shown below.

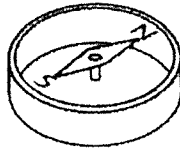

He placed a bar magnet on a plastic strip and floated it in a basin of water.

Which of the following correctly represents the position of the bar magnet when it comes to rest?

(1)

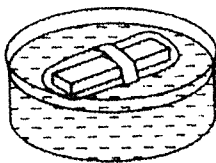

(2)

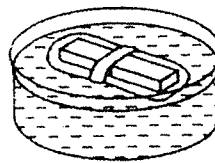

(3)

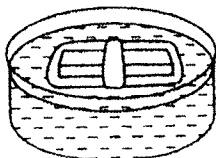

(4)

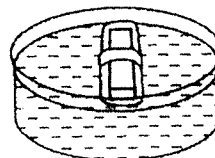

9 The arrows show the direction of movement of the magnet.

Which of the following correctly shows how an iron nail is magnetised using the stroke method?

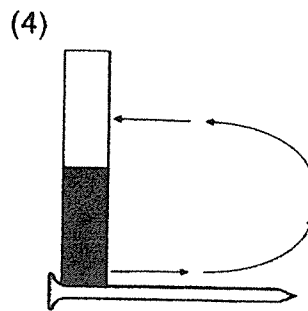
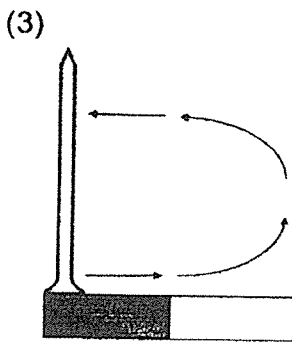
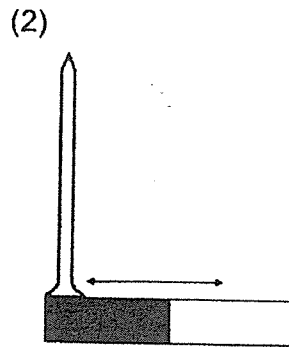
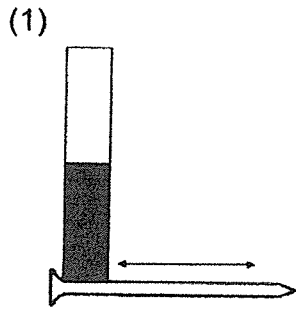

10 The diagram below shows the life cycle of a mealworm beetle.

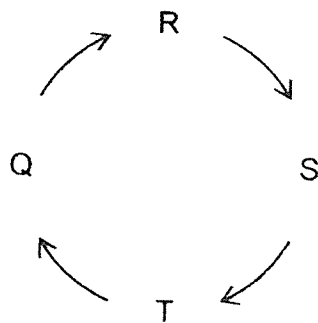

If T represents the adult stage, at which stage(s) would the mealworm beetle eat a lot and moult several times?

- (1) Q only
- (2) R only
- (3) R and S only
- (4) S and T only

11 Study the life cycles of animals J and K.

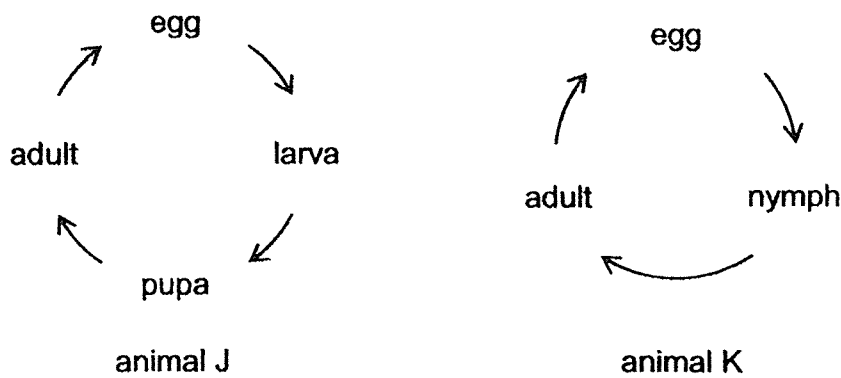

Based on the diagrams above, which statements are correct?

- A Both animals reproduce by laying eggs.
- B Animal J has more stages in its life cycle than animal K.
- C Animal J takes a longer time than animal K to develop from an egg to an adult.

- (1) A and B only
- (2) A and C only
- (3) B and C only
- (4) A, B and C

12 Muthu observed two animals P and Q. He then recorded his observations in the table below.

Observation	animal P	animal Q
has 6 legs		✓
lays eggs in water	✓	✓
has a 3-stage life cycle	✓	

Which of the following correctly identifies animals P and Q?

	animal P	animal Q
(1)	chicken	frog
(2)	frog	mosquito
(3)	mosquito	beetle
(4)	beetle	chicken

- 13 The table below shows the development of a flowering plant over a period of time.

Stage	Development of flowering plant
W	Leaves develop to make food.
X	Roots grow downwards.
Y	Flowers appear on the plant.
Z	Shoot grows upwards.

Which of the following correctly shows the order of development?

- (1) Z → W → X → Y
- (2) Z → X → Y → W
- (3) X → Z → W → Y
- (4) X → W → Z → Y

- 14 Which statement is correct?

- (1) All plants grow from spores.
- (2) A young plant has a similar life cycle to its parent.
- (3) A young plant has more leaves than an adult plant.
- (4) The life cycle of a plant comes to an end when the plant becomes an adult.

- 15 Which is matter?

- (1) wind
- (2) music
- (3) sound
- (4) shadow

16 Which of the following is the most suitable to measure 15 ml of water?

(1)

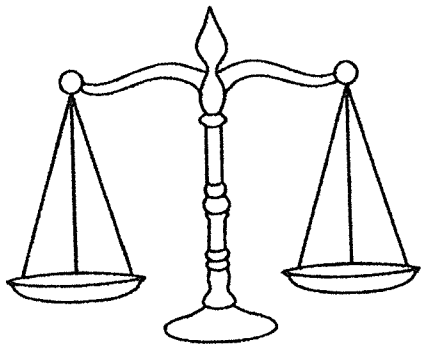

(2)

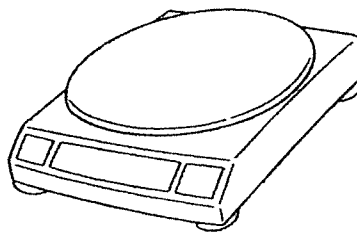

(3)

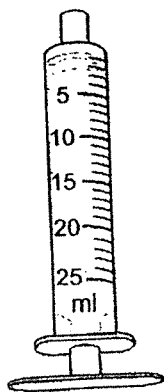

(4)

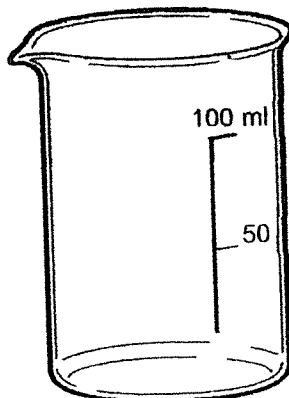

17 Gareth placed a deflated ball on an electronic balance and recorded its mass. Then, he pumped air into the deflated ball and placed it on the electronic balance again.

deflated ball

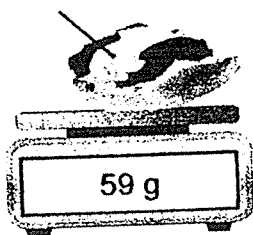

inflated ball

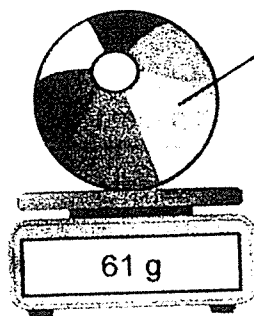

Based on the diagrams above, what can we say about the property of air?

- (1) Air has mass.
- (2) Air has a definite shape.
- (3) Air does not occupy space.
- (4) Air does not have a definite volume.

18 Ashley has two packets of snacks A and B.

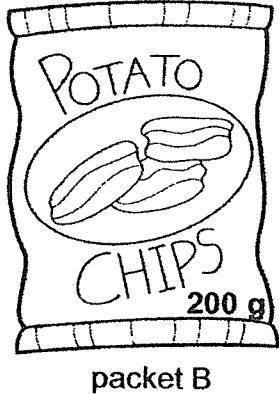
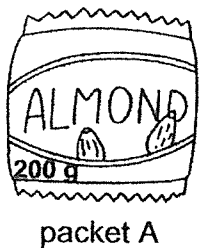

Based on the diagram, which of the following best describes the packets?

- (1) Packet A has a greater mass than packet B.
- (2) Packet B has a greater mass than packet A.
- (3) Packet A has a greater volume than packet B.
- (4) Packet B has a greater volume than packet A.

19 Zhi Wen placed metal cubes of different sizes into each of the beakers P, Q, R and S as shown below. He then filled each beaker with water to the same level.

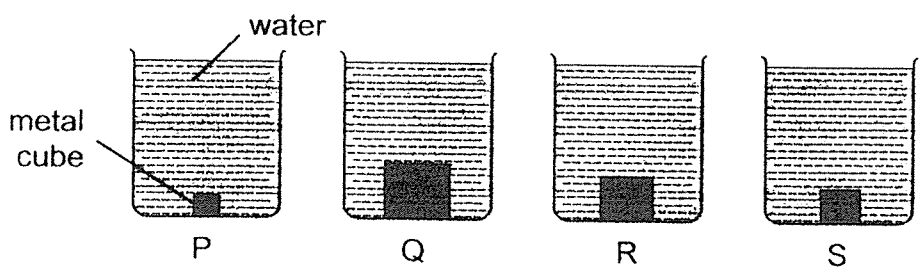

Which beaker had the least amount of water?

- (1) P
- (2) Q
- (3) R
- (4) S

20 The table below shows the properties of substances A and B.

Properties	substance A	substance B
definite volume	yes	no
definite shape	no	no
has mass	yes	yes

A 1-litre bottle contains 300 cm^3 of substance A and 700 cm^3 of substance B.

If another 100 cm^3 of substance B is added to the bottle, what is the volume of substance B in the bottle now?

- (1) 600 cm^3
- (2) 700 cm^3
- (3) 800 cm^3
- (4) 1000 cm^3

21 Which is a source of light?

- A a star
- B the Sun
- C the Moon
- D a candle flame

- (1) B and D only
- (2) C and D only
- (3) A, B and C only
- (4) A, B and D only

22 Which arrows best show how light is reflected into the eye?

(1)

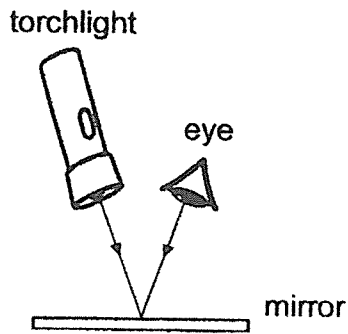

(2)

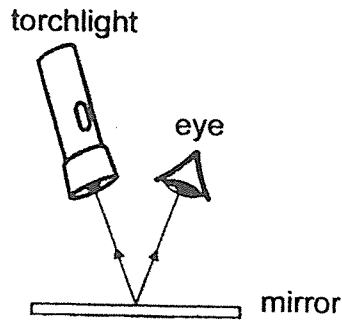

(3)

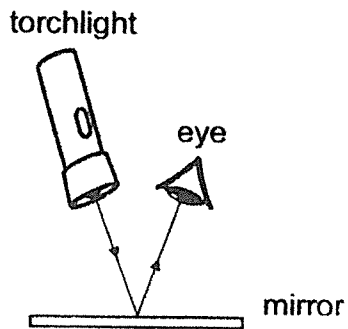

(4)

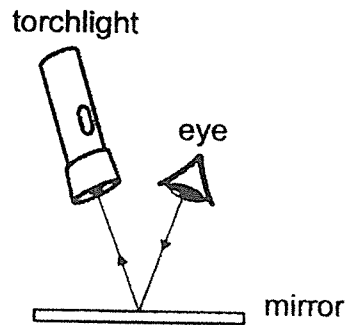

23 In a completely dark room, four sheets E, F, G and H were arranged in a straight line as shown below. When the torch was turned on, a bright circular patch of light was observed only on sheet G.

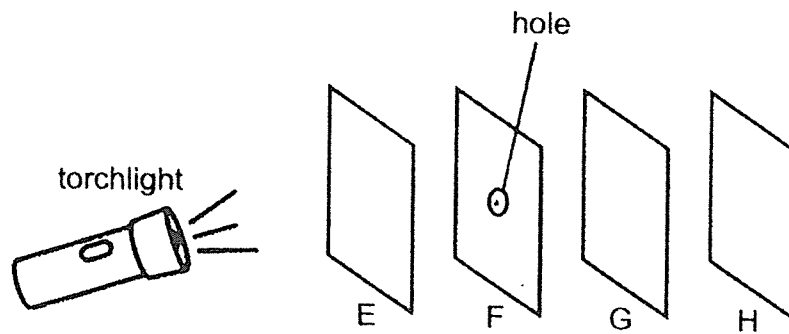

Based on the information above, which statement is correct?

- (1) Sheets E and F allowed light to pass through them.
- (2) Sheets G and H allowed light to pass through them.
- (3) Sheets E and H did not allow any light to pass through them.
- (4) Sheets F and G did not allow any light to pass through them.

- 24 The table below shows the different amounts of light that can pass through material W, X, Y and Z.

Material	Amount of light (units)
W	300
X	150
Y	0
Z	450

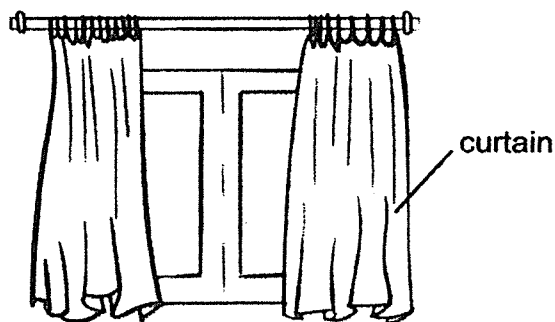

Which is the best material to make a curtain to ensure that the room is completely dark?

- (1) W
- (2) X
- (3) Y
- (4) Z

End of Booklet A

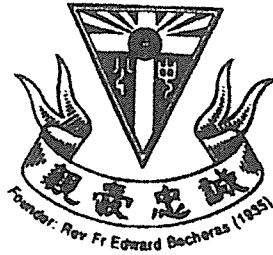

CATHOLIC HIGH SCHOOL
MID-YEAR EXAMINATION (2022)
PRIMARY FOUR
SCIENCE
BOOKLET B

Name: _____ ()

Class: Primary 4 - _____

Date: 12 May 2022

Parent's Signature: _____

Booklet A	48
Booklet B	32
Total	80

11 questions

32 marks

Total Time for Booklets A and B: 1 hour 30 minutes

INSTRUCTIONS TO CANDIDATES

Do not turn over this page until you are told to do so.
Follow all instructions carefully.
Answer all questions.
Write your answers in this booklet.

This booklet consists of 12 printed pages, excluding the cover page.

Booklet B (32 marks)

For questions 25 to 35, write your answers in this booklet.

The number of marks available is shown in brackets [] at the end of each question or part question. (32 marks)

25 The diagram below shows animal A.

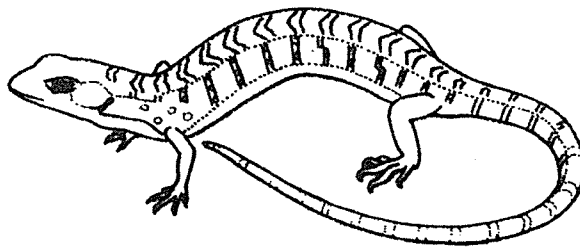

Give two reasons why animal A is **not** an insect.

[2]

Reason 1: _____

Reason 2: _____

(Go on to the next page)

SCORE	2
-------	---

26 Study the diagram.

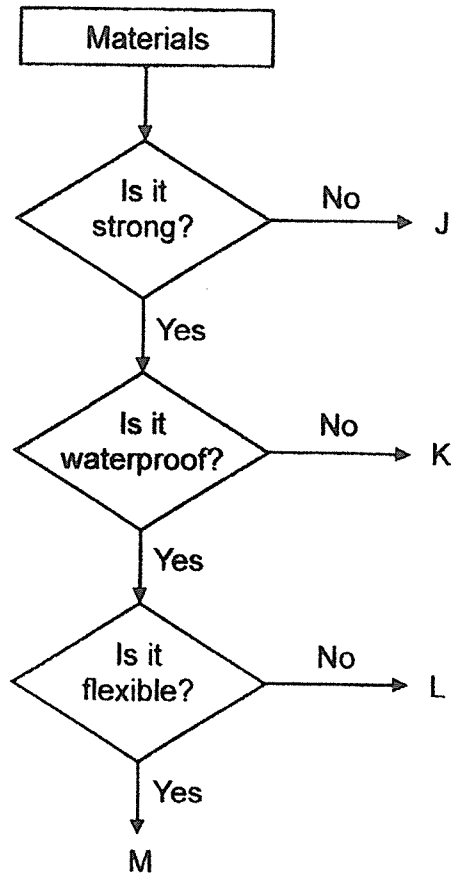

(a) State the similarity between materials K and M. [1]

(b) Based on the diagram above, which material J, K, L or M is most suitable to make a lock? Give reasons for your answer. [1]



(Go on to the next page)

SCORE	/
	2

27 The diagram below shows parts of the human digestive system.

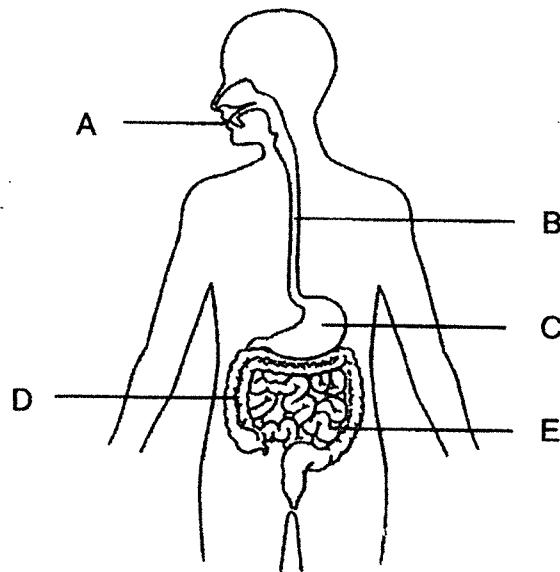

(a) Name parts B and E. [1]

part B: _____

part E: _____

(b) Which parts A, B, C, D or E of the digestive system are digestive juices produced? [1]

(c) How do the teeth help in the process of digestion? [1]

(Go on to the next page)

SCORE	
-------	--

28 Boon Hwee conducted an experiment using two similar set-ups A and B. In set-up B, he wrapped the roots of the plant in a plastic bag.

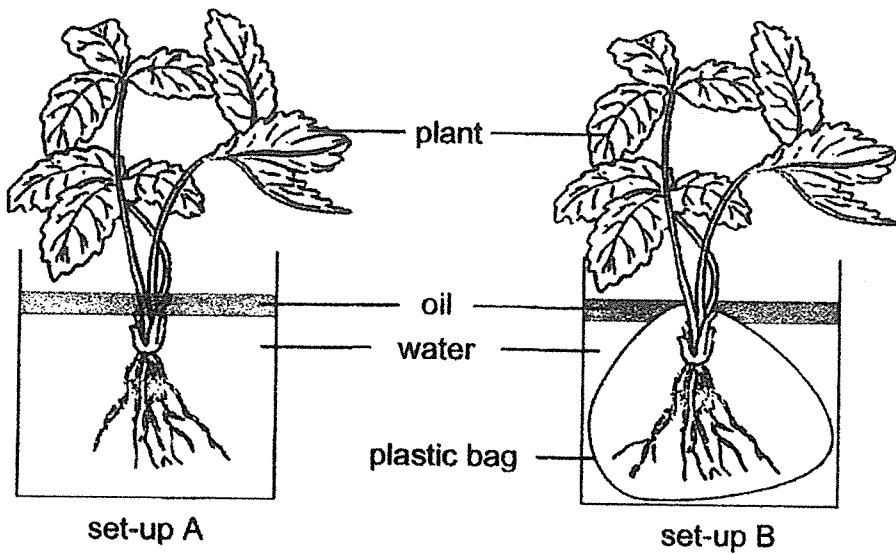

(a) Compare the water levels in the two containers after a few days. [1]

(b) Based on the answer in (a), what could Boon Hwee conclude from the above experiment? [1]

(c) Put a tick (✓) in the correct boxes below to indicate if the following three variables should be changed or kept the same. [1]

Variables	Changed	Kept the same
type of plant		
number of leaves		
location of set-ups		

(Go on to the next page)

SCORE	3
-------	---

- 29 Lincoln wanted to find out the strength of an electromagnet using the set-up below.

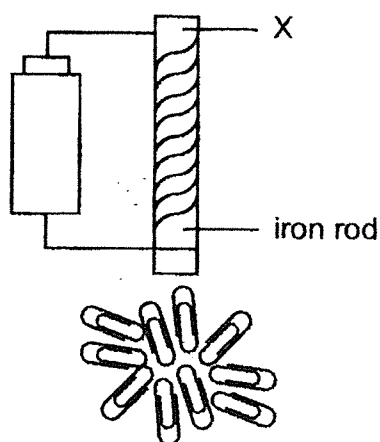

His results are as shown.

Number of turns of wire	Numbers of paper clips attracted
10	0
20	1
30	4

- (a) Explain why no paper clips were attracted to the electromagnet with 10 turns of wire around the iron rod.

[1]

- (b) How could Lincoln show that end X of the rod was a North pole using a bar magnet?

[1]

(Go on to the next page)

SCORE	2
-------	---

Continue from Question 29

- (c) What would happen to the number of paper clips attracted when the iron rod was replaced with a wooden rod? [1]

- (d) Give a reason for your answer in (c). [1]

(Go on to the next page)

SCORE	
-------	---

30 The set-up below consists of three ring magnets supported by a wooden rod.

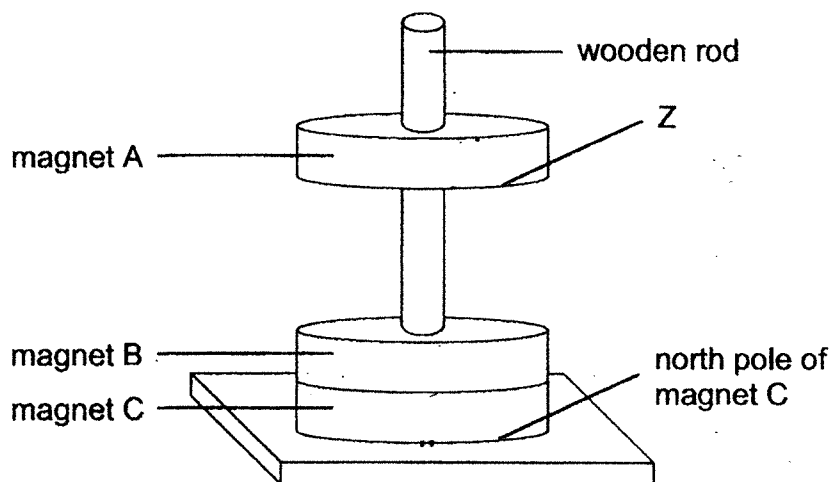

(a) Identify the pole of magnet A, labelled Z, that is facing magnet B in the set-up above. [1]

(b) Explain why magnet A is 'floating' in the air. [2]

(Go on to the next page)

SCORE	3
-------	---

- 31 A mosquito lays eggs in water. Its larvae eat microorganisms that are found in the water. The larvae are food for other living things in the pond.

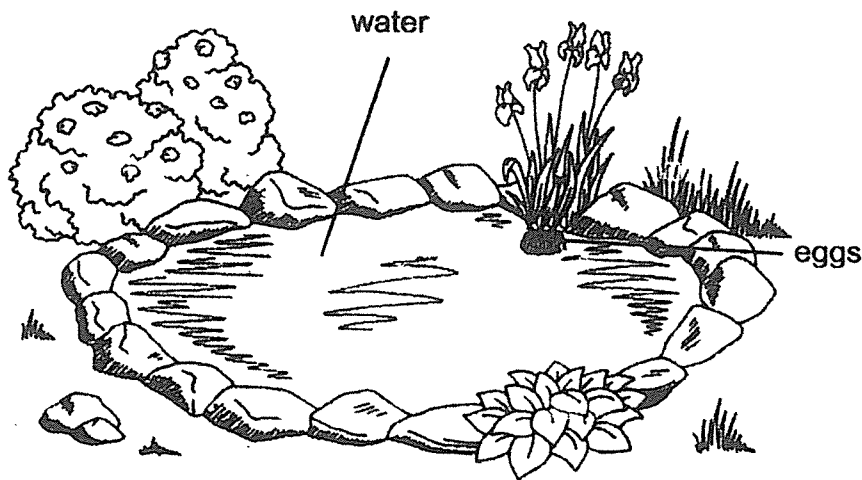

- (a) Suggest a reason why the mosquito lays eggs in water. [1]

- (b) How does laying many eggs help in the survival of mosquito? [1]

- (c) At which stage of the life cycle of a mosquito would it be most difficult to get rid of? Give a reason. [1]

(Go on to the next page)

SCORE	3
-------	---

32 The diagrams below show a plant at different stages of its life cycle.

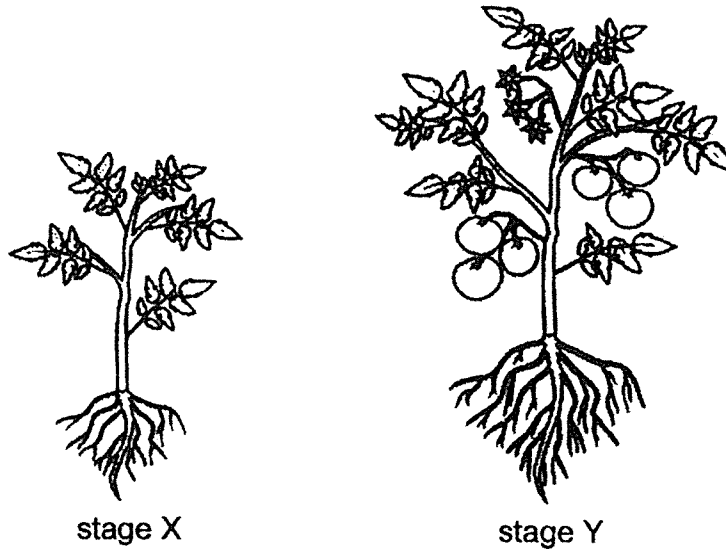

(a) Name stages X and Y. [1]

stage X: _____

stage Y: _____

(b) State a difference between the two stages in (a). [1]
(Do not compare size and colour.)

(c) How does the plant above reproduce? [1]

(Go on to the next page)

SCORE	3
-------	---

- 33 Fatimah conducted an experiment in a room by placing substances F and G in two similar containers, tilted to one side. The diagrams below show what happened to the substances after an hour.

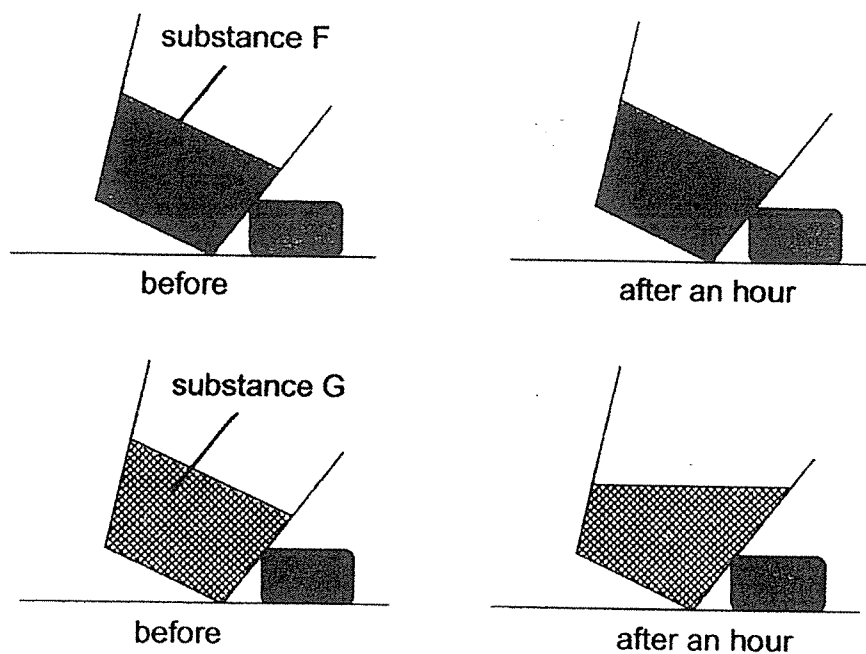

- (a) Name the states of substances F and G after an hour. [1]

state of substance F: _____

state of substance G: _____

- (b) Suggest what substance G could be at the start of the experiment. [1]

(Go on to the next page)

SCORE	2
-------	---

34 The diagram below shows a metal can with a spout filled with water.

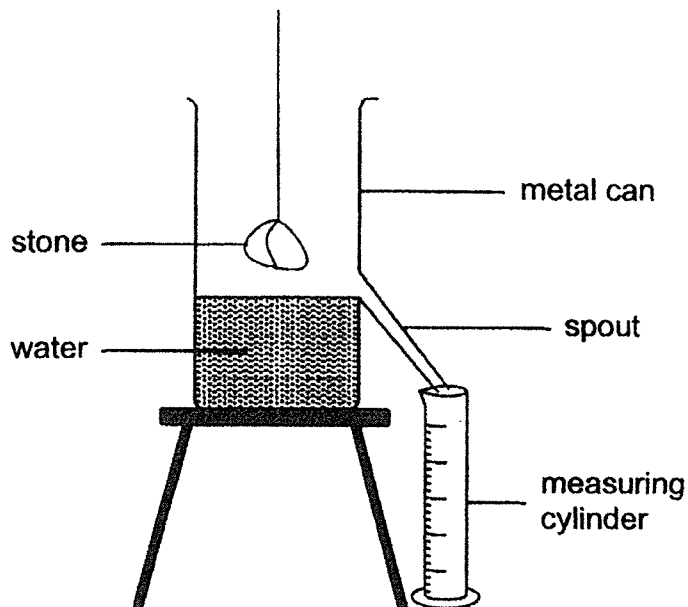

(a) What will be observed when a stone is lowered into the metal can as shown? [1]

(b) What does this experiment show about the property of the stone? [1]

(c) Based on the diagram above, what can be obtained using the measuring cylinder? [1]

Tick (✓) the correct box.

- mass of the stone
- shape of the stone
- volume of the stone

(Go on to the next page)

SCORE	3
-------	---

35 Meimei conducted an experiment using three similar cups made of different materials X, Y and Z. She placed 8 similar balls into each cup.

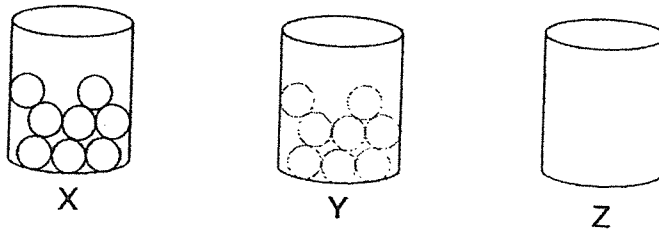

She recorded her observation in the table below.

Material	Observation
X	can see the balls in the cup clearly
Y	cannot see the balls in the cup clearly
Z	cannot see the balls in the cup at all

(a) The diagram below shows a car.

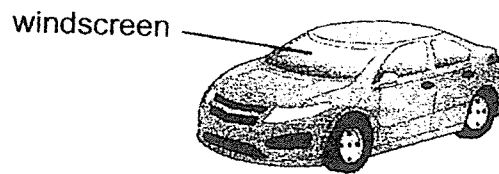

Which material X, Y or Z is the most suitable for making the windscreen of a car? Explain your answer.

[2]

(b) Based on the results of the experiment, classify the objects below using the table.

[2]

clear glass	tracing paper
metal spoon	wooden ruler

material X	material Y	material Z

SCORE	4
-------	---

End of Booklet B



YEAR : 2022
LEVEL : PRIMARY 4
SCHOOL : CATHOLIC HIGH SCHOOL
SUBJECT : SCIENCE
TERM : MID-YEAR EXAMINATION

(BOOKLET A)

Q1	3	Q2	4	Q3	3	Q4	1	Q5	4
Q6	1	Q7	2	Q8	1	Q9	4	Q10	2
Q11	1	Q12	2	Q13	3	Q14	2	Q15	1
Q16	3	Q17	1	Q18	4	Q19	2	Q20	2
Q21	4	Q22	3	Q23	4	Q24	3		

(BOOKLET B)

Q25	Reason 1: It does not have six legs but four. Reason 2: Insects has three body parts and does not have a hard outer body covering.								
Q26	a)	Both K and M is a strong material.							
	b)	Material L. A lock must be strong, waterproof and not flexible like material L.							
Q27	a)	part B: Gullet part E: Small intestine							
	b)	A, C and E							
	c)	It helps to chew the food into smaller pieces for easy swallowing.							
Q28	a)	The water level in set-up A is lower than the water level insect-up B.							
	b)	Roots absorb water for the plant.							
	c)	Variables	Changed			Kept the same			
		type of plant							
number of leaves									
	location of set-ups								
Q29	a)	The electromagnet was not strong enough to attract any paper clips.							
	b)	Place a magnet with its North Pole facing point X. If they repel, point X is the North pole of the electromagnet, if they are attracted, point X is the South pole.							
	c)	No paper clips would be attracted to the wooden rod.							
	d)	Wood is a non-magnetic material hence, it cannot be magnetized.							
Q30	a)	South pole							
	b)	The poles of magnet A and B facing each other are like poles, like poles repel.							
Q31	a)	So the young of the mosquito has food when given birth as it feeds on tiny organisms.							
	b)	So that it increases the chances of a mosquito survive until adulthood as it could have been eaten by predators.							
	c)	At the adult stage. During adult stage, mosquitos has wings and flying							

		around preventing predators.		
Q32	a)	stage X: seedling stage Y: adult plant		
	b)	The adult plant has fruits whereas the young plant does not have fruits.		
	c)	It reproduces by seeds		
Q33	a)	state of substance F: Solid state of substance G: Liquid		
	b)	Ice		
Q34	a)	The water will overflow and be collected in the measuring cylinder.		
	b)	Stone occupies space		
	c)	volume of the stone		
Q35	a)	X. The windscreen on a car is supposed to allow most light to pass through and the balls can be seen most clearly and most light to pass through, thus, making it suitable.		
	b)	material X clear glass	material Y tracing paper	material Z metal spoon wooden ruler

2
END