



RED SWASTIKA SCHOOL

2022 END OF YEAR EXAMINATION

SCIENCE

Name : _____ ()

Class : Primary 4 / _____

Date : 1 NOVEMBER 2022

BOOKLET A

28 Questions

56 Marks

Duration of Paper : 1 hour 30 minutes

Note:

- 1. Do not open this Booklet until you are told to do so.**
- 2. Read carefully the instructions given at the beginning of each part of the Booklet.**
- 3. Do not waste time. If a question is difficult for you, go on to the next one.**
- 4. Check your answers thoroughly and make sure you attempt every question.**
- 5. In this booklet, you should have the following:**
 - (a) Page 1 to Page 21**
 - (b) Questions 1 to 28**

For questions 1 to 28, choose the most suitable answer and shade its number in the OAS provided.

1. A millipede curls itself up when touched.

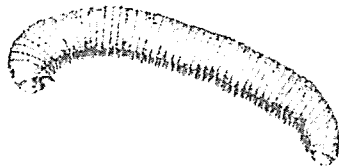

a millipede
(before touching)

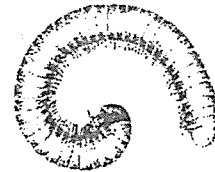

a millipede curls up
(after touching)

This shows that the millipede is a living thing because it can _____.

- (1) die
- (2) move
- (3) respond
- (4) reproduce

2. Which one of the following objects can be bent easily without breaking?

(1)



A glass cup

(2)

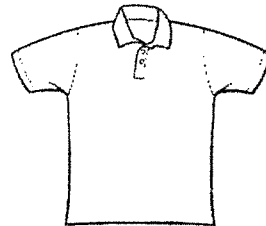

A shirt

(3)



A plastic fork

(4)

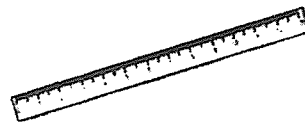

A wooden ruler

3. Which one of the following shows the correct order when food moves through some parts of the digestive system?

(1)



stomach

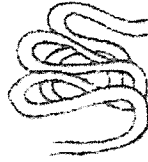

small intestine

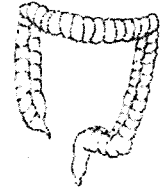

large intestine

(2)

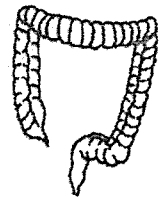

large intestine

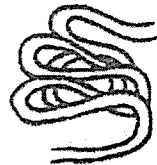

small intestine

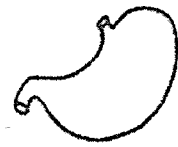

stomach

(3)

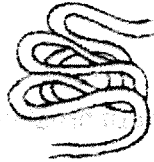

small intestine

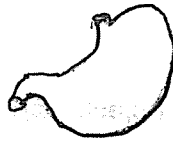

stomach

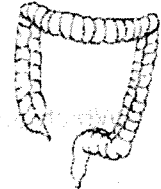

large intestine

(4)



stomach



large intestine



small intestine

4. Which part (1), (2), (3) or (4) takes in water for the plant?

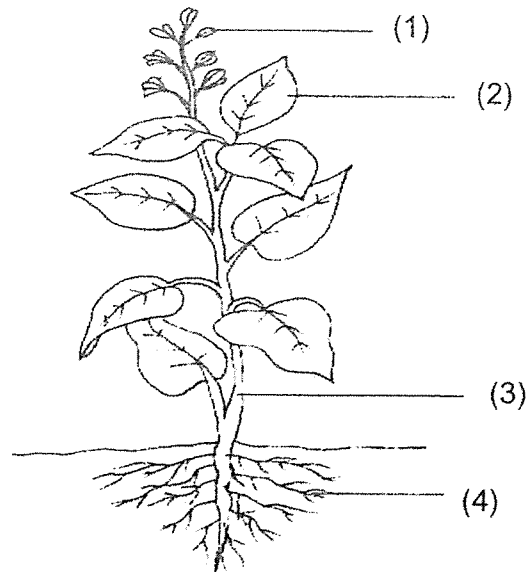

5. The diagram below shows the life cycle of an animal.

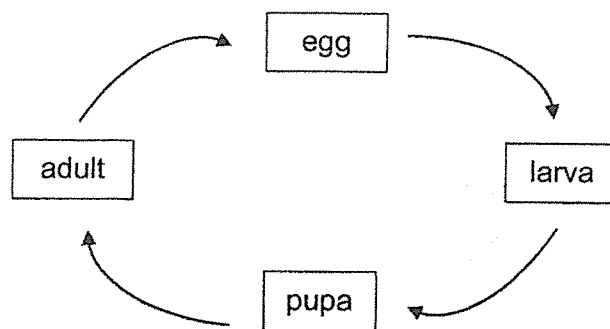

Which animal is most likely to have the life cycle as shown above?

- (1) frog
- (2) beetle
- (3) chicken
- (4) grasshopper

6. The diagram below shows the growth of a young plant with two missing stages A and C.

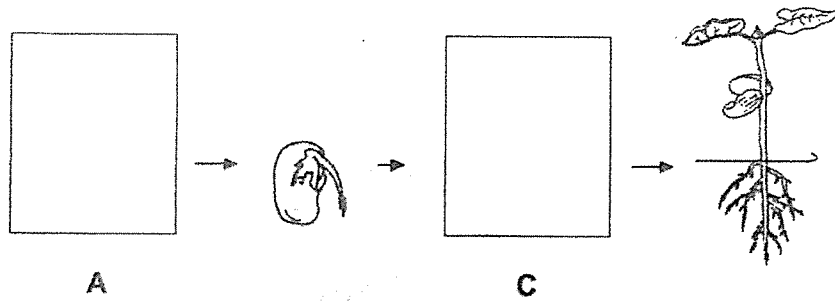

Which one of the following shows the correct stages for A and C?

	A	C
(1)		
(2)		
(3)		
(4)		

7. In the diagram, what is the volume of liquid X?

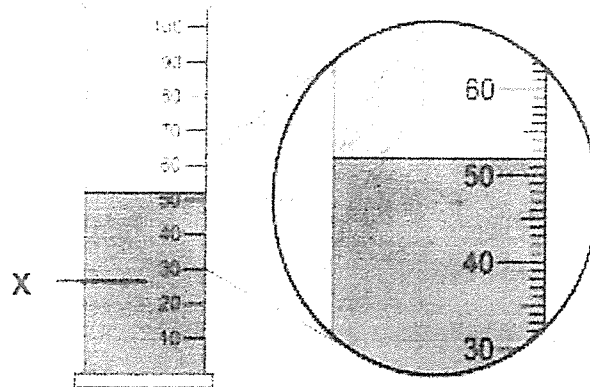

- (1) 51 ml
- (2) 52 ml
- (3) 62 ml
- (4) 68 ml

8. Which one of the following is a source of light?

(1)



a fire

(2)

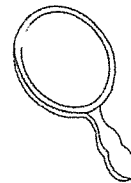

a mirror

(3)

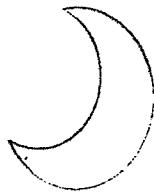

a moon

(4)



an apple

9. Rahman places a metal spoon into a cup of hot water.

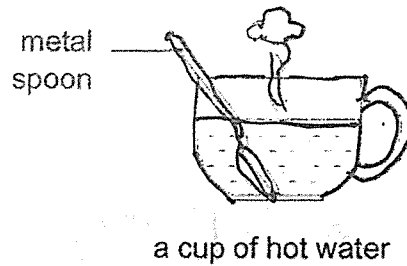

The spoon becomes hotter after a while.

Which one of the following explains this?

- (1) The cup loses heat to the hot water.
- (2) The spoon loses heat to the hot water.
- (3) The spoon gains heat from the hot water.
- (4) The hot water gains heat from the spoon.

10. In which one of the following will the two magnets push each other away?

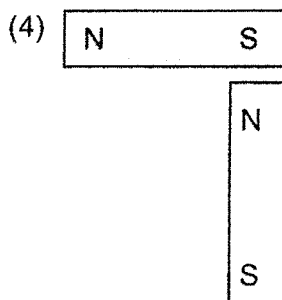
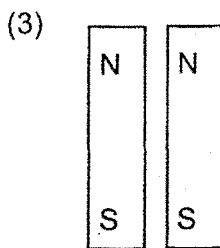
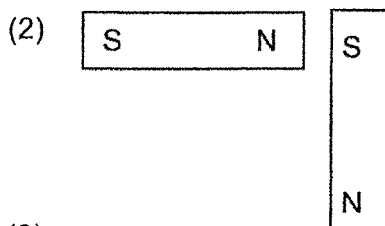
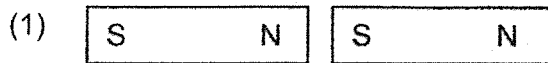

11. Ben found the following type of organism growing in the school field.

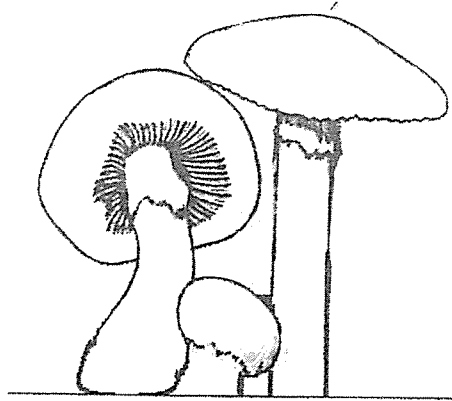

He made the following statements about the organism.

- A : They are fungi.
- B : They can reproduce.
- C : They are plants without leaves.
- D : They are non-flowering plants because they contain spores.

Which of the following statements is/are correct?

- (1) A only
- (2) A and B only
- (3) B and D only
- (4) C and D only

12. Study the flowchart below.

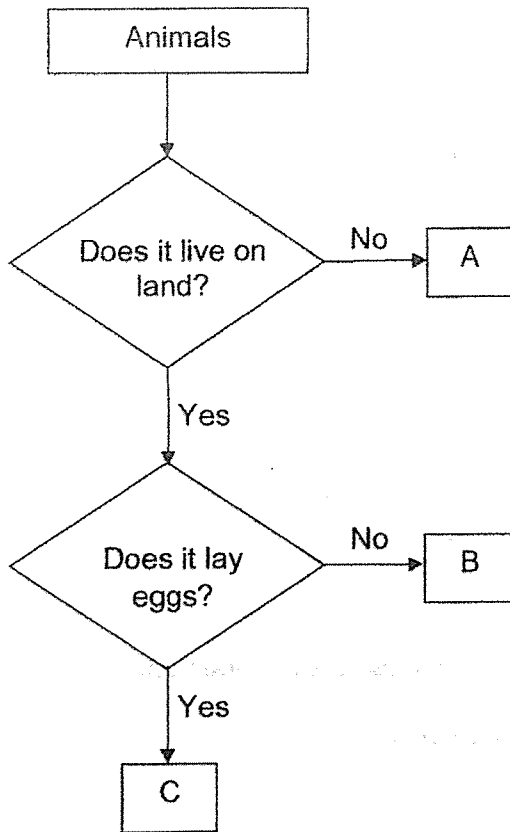

Which of the following shows the correct animal groups for A, B and C?

	A	B	C
(1)	insect	mammal	fish
(2)	mammal	fish	insect
(3)	fish	insect	mammal
(4)	fish	mammal	insect

13. Heidi observed two plants in her school garden.

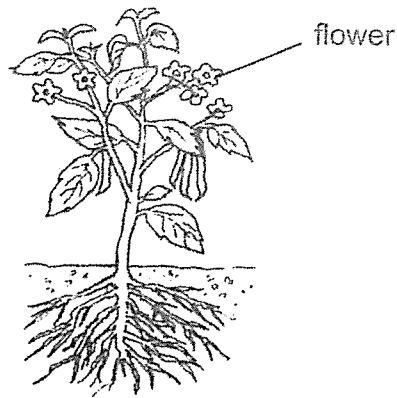

Plant A

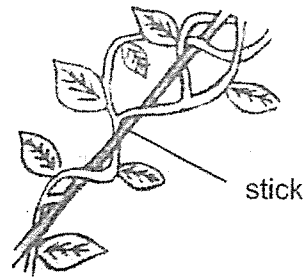

Plant B

Based on her observations, she classified both plants into the classification chart below.

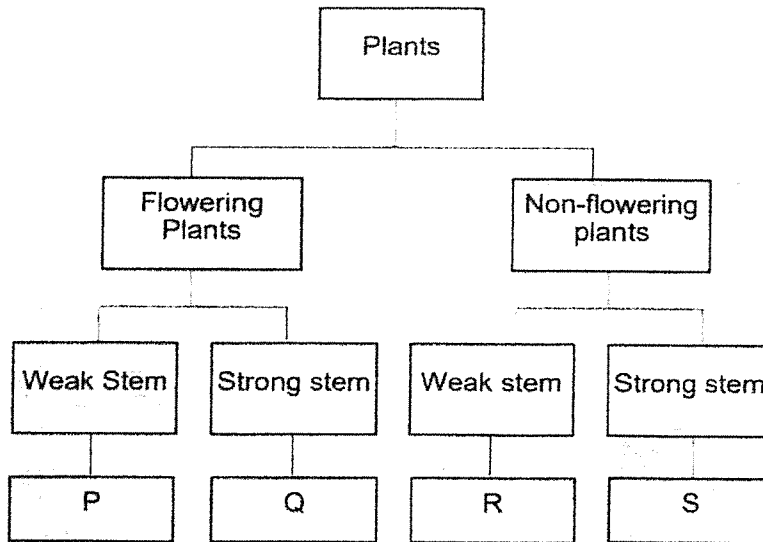

Which letters, P, Q, R, and S in the chart best represent Plant A and Plant B?

	Plant A	Plant B
(1)	Q	R
(2)	Q	S
(3)	P	S
(4)	S	Q

14. The diagram below shows how three body systems, A, B and C, work together to transport digested food and air to all parts of the body.

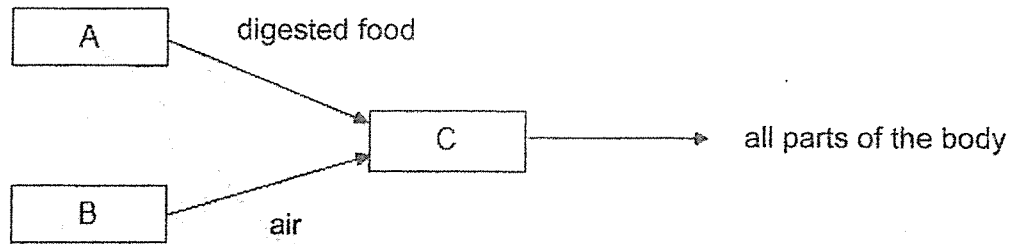

Which one of the following identifies systems, A, B and C correctly?

	A	B	C
(1)	digestive	respiratory	circulatory
(2)	digestive	circulatory	respiratory
(3)	circulatory	digestive	muscular
(4)	skeletal	digestive	circulatory

15. Observe the two plants carefully.

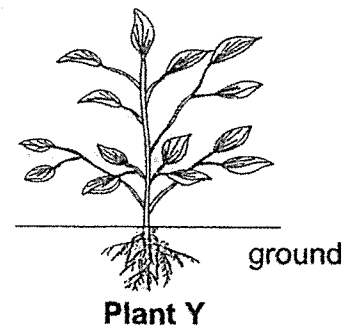
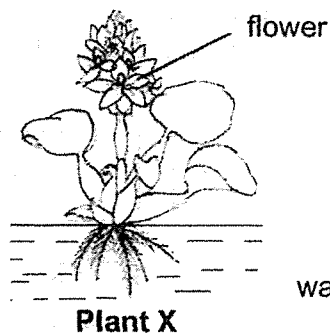

Based on your observations, which of the following statements about the two plants are true?

- A Plant X has flowers but plant Y does not. ✓
- B Both plant X and plant Y have roots. ✓
- C Both plant X and plant Y are land plants.

- (1) A and B only
- (2) A and C only
- (3) B and C only
- (4) A, B and C

16. The diagram shows the life cycle of a butterfly.

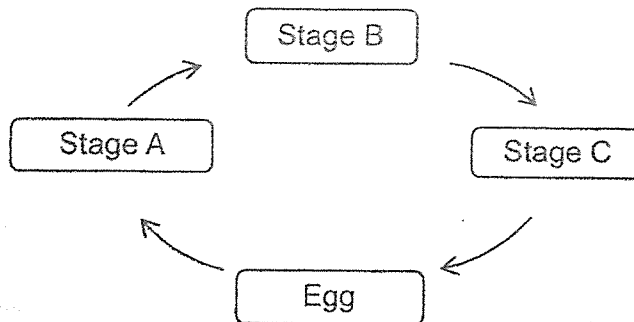

Which one of the following shows stages A, B and C correctly?

	Stage A	Stage B	Stage C
(1)	Adult	Larva	Pupa
(2)	Pupa	Adult	Larva
(3)	Pupa	Larva	Adult
(4)	Larva	Pupa	Adult

17. Seeds W, X, Y and Z from a plant are placed under the conditions as shown.

seed	conditions				Temperature (°C)
	water	air	light		
W	√	X	√		25
X	√	√	X		25
Y	X	√	X		5
Z	X	√	√		5

Key
√ : present
X : absent

Which seed can germinate?

- (1) W
- (2) X
- (3) Y
- (4) Z

18. Diagram 1 below shows 3 substances, R, S and T, placed in identical containers on a table.

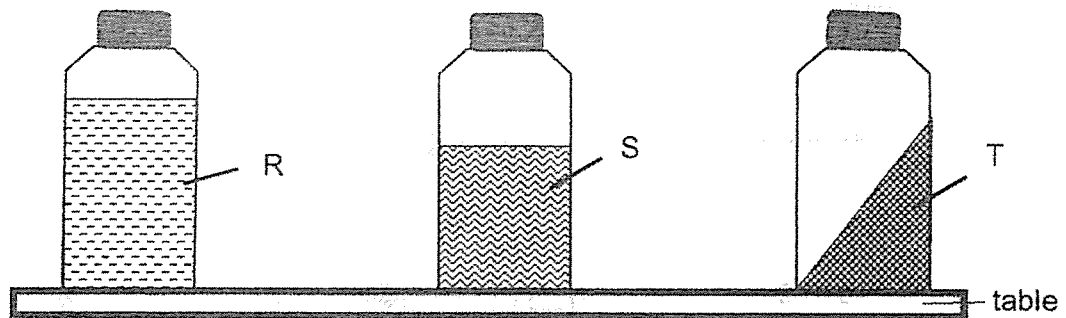

Diagram 1

These containers are then placed in a different position as shown in diagram 2 below.

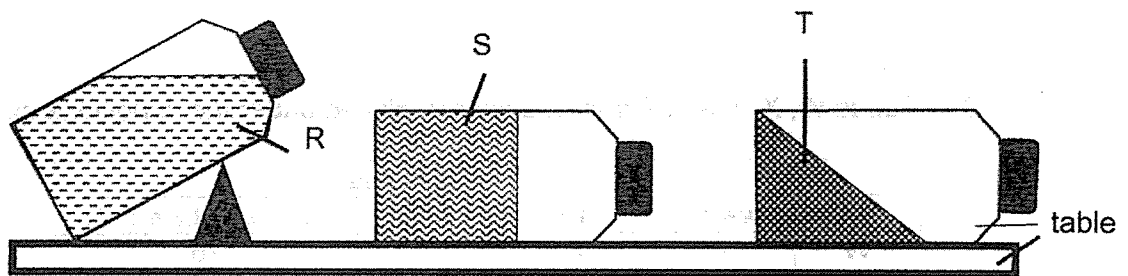

Diagram 2

Based on the two diagrams, which of the following conclusions about the substances are correct?

- A : Substance R is a liquid.
- B : Substance T is a solid.
- C : Only substances S and T have definite shapes.
- D : Only substances S and T have definite volumes.

- (1) A and D only
- (2) B and C only
- (3) A, B and C only
- (4) A, B, C and D

19. Two identical syringes, P and Q, contain substances X and Y respectively. One end of each syringe is sealed. The plunger in syringe P could not be pushed in while the plunger in syringe Q could be pushed in slightly as shown in the diagram below.

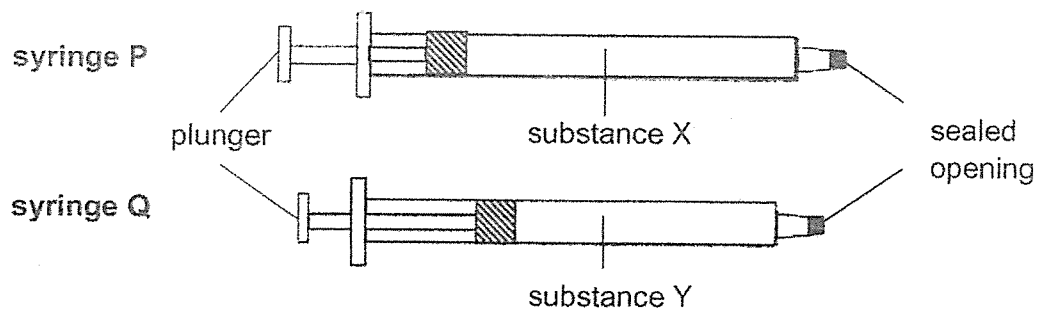

Which of the following substances are X and Y most likely to be?

	X	Y
(1)	air	water
(2)	carbon dioxide	oxygen
(3)	water	oil
(4)	water	air

20. Four different materials A, B, C and D of equal length and thickness were used in an experiment set-up shown below.

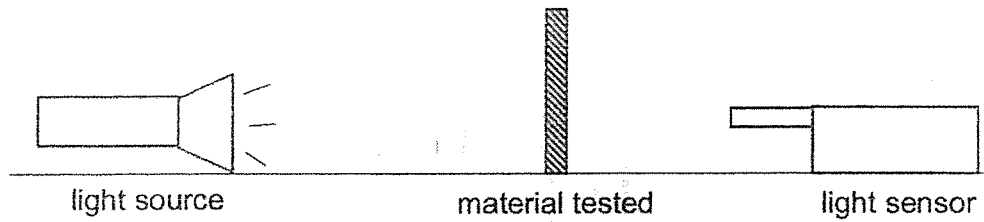

A light sensor was used to measure the amount of light that can pass through each material. The results are shown in the table below.

Material	Amount of light (units)
No material	5000
A	4800
B	390
C	2500
D	25

Based on the picture, which material A, B, C or D is most suitable for making part M of a face shield?

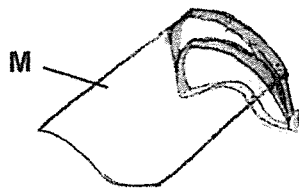

- (1) A
- (2) B
- (3) C
- (4) D

21. Three rods made of different materials are placed into a beaker of cold water.

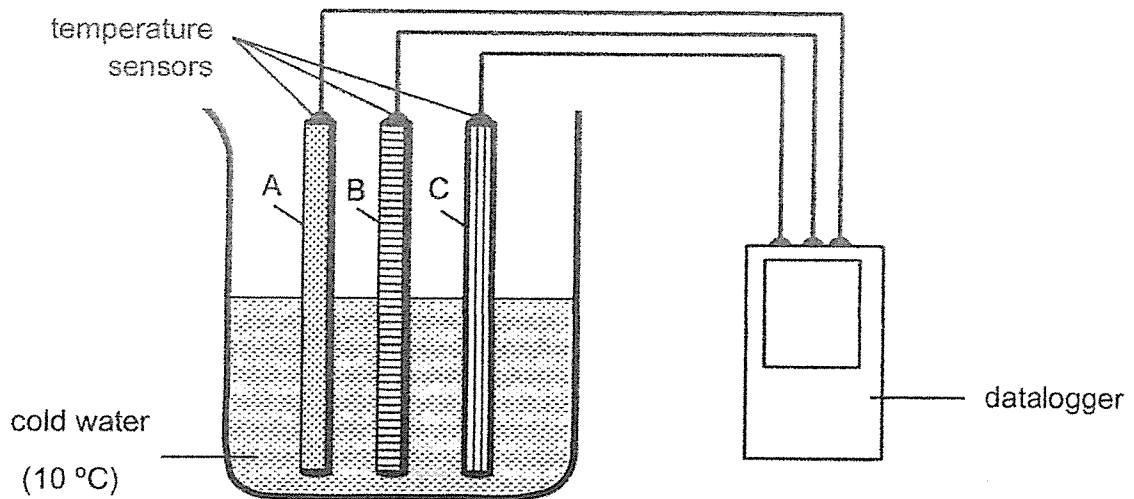

The table below shows how the temperature of each rod changed after ten minutes.

Rod	Temperature of rods (°C)	
	Before being placed in the cold water (°C)	After being placed in cold water (°C)
A	25	15
B	25	22
C	25	19

Based on the results above, arrange the rods according to how well they conduct heat, starting from the best to the poorest conductor of heat.

	best	→	poorest
(1)	A	B	C
(2)	B	C	A
(3)	A	C	B
(4)	C	B	A

22. Mrs Tan demonstrated to her students how shadows were formed. She prepared set-ups A and B as shown below.

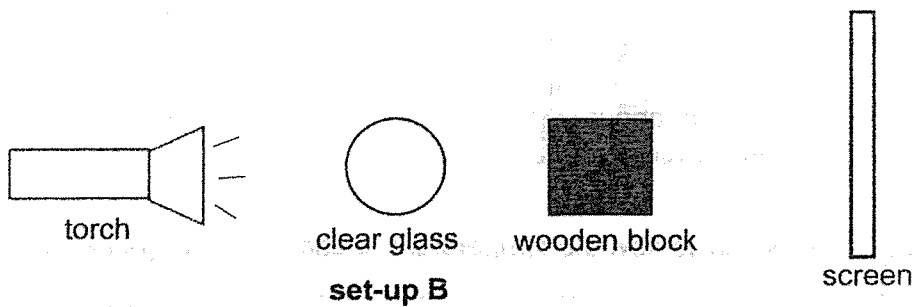
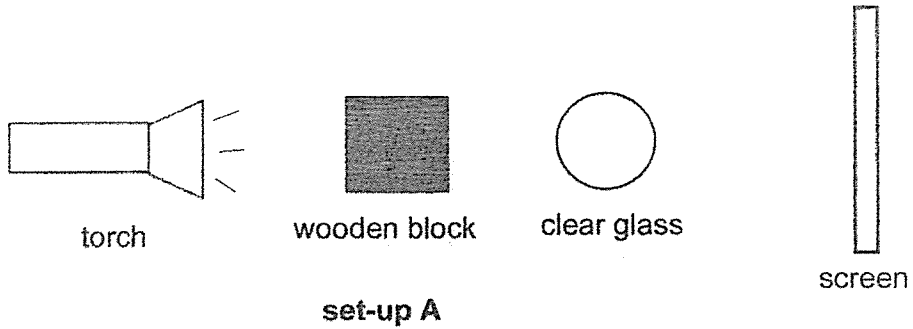

What would the students see on the screen of each set-up?

	set-up A	set-up B
(1)		
(2)		
(3)		
(4)		

23. Study the diagram below. There is only one light source shining on the pole.

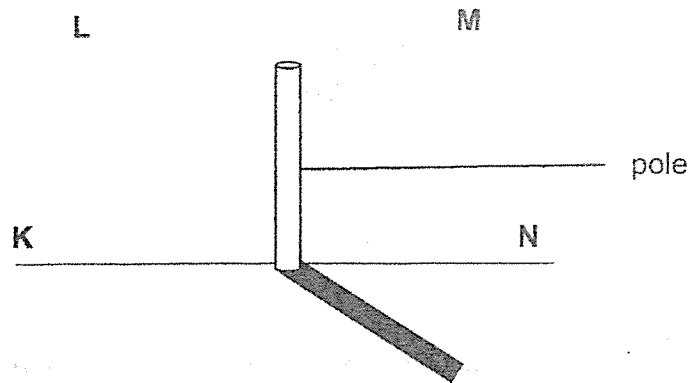

Based on the diagram above, which position, K, L, M or N best represents the position of the light source?

- (1) K
- (2) L
- (3) M
- (4) N

24. Ramesh carried out an experiment to find out how the volume of water affects the time taken for the water to be heated up to 100°C .

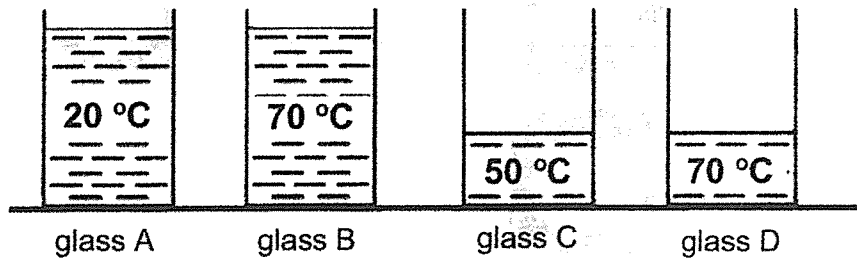

In order for the experiment to be fair, which two glasses should he use for his experiment?

- (1) A and B
- (2) A and D
- (3) B and C
- (4) B and D

25. Ben took an ice cube from the freezer and put it in a bowl. He left the bowl on the kitchen table for an hour. After that, he placed the bowl of water into the refrigerator. The temperature of the ice and water are recorded.

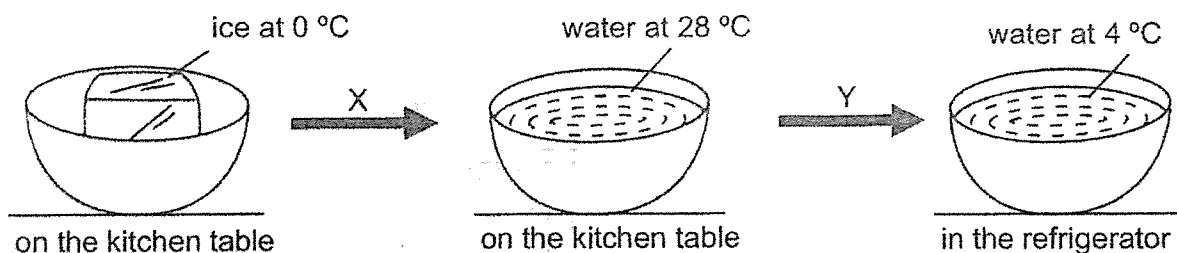

Which one of the following correctly describes what happens during X and Y?

	X	Y
(1)	The ice cube loses heat to the surroundings.	Water gains heat from the surroundings.
(2)	The ice cube gains heat from the surroundings.	Water loses heat to the surroundings.
(3)	The ice cube gains heat from the surroundings.	Water gains heat from the surroundings.
(4)	The ice cube loses heat to the surroundings.	Water loses heat to the surroundings.

26. Daniel poured 100 ml of water at room temperature into a beaker. He then placed material X below the beaker as shown below.

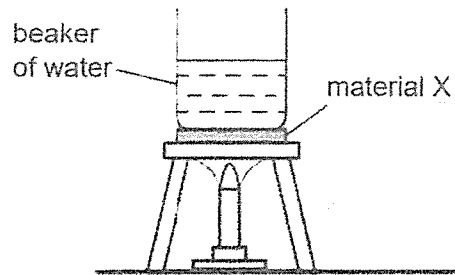

He heated the water in the beaker using a heat source. He then repeated the experiment with different materials, Y and Z that are of equal thickness. He recorded the time taken for the beaker of water to boil in the table below.

Material	Time taken for the water to boil (min)
X	2
Y	8
Z	5

Which one of the following statements is true?

- (1) Material Y is the best conductor of heat.
- (2) Materials X, Y and Z can conduct heat equally well.
- (3) Material X is a better conductor of heat than Material Z.
- (4) Material Z is a poorer conductor of heat than Material Y.

27. Diagram 1 shows a magnetic doorstopper that has a magnet each at part A and part B.

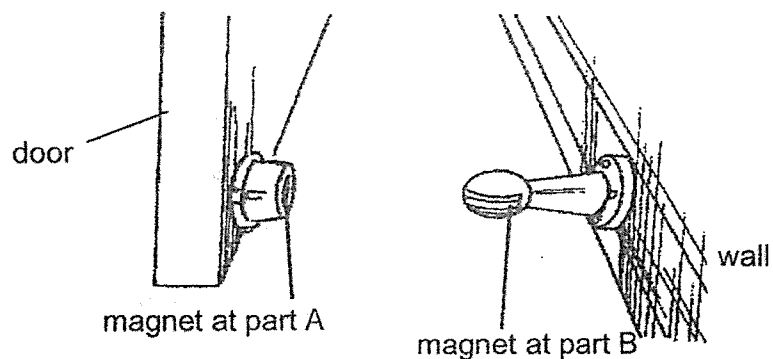

Diagram 1

In order to keep the door open, part A and part B have to be in contact as shown below in diagram 2.

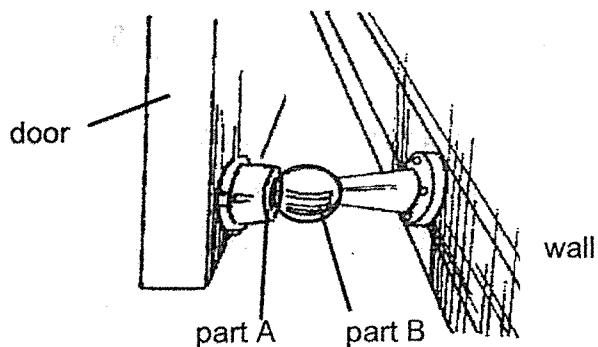
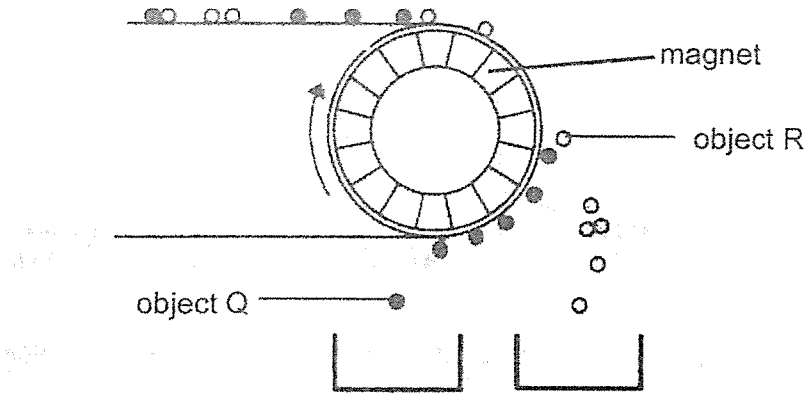

Diagram 2

Which one of the following statements explain how the magnets work together to keep the door open?

- (1) The like poles of both magnets repel each other.
- (2) The like poles of both magnets attract each other.
- (3) The unlike poles of both magnets repel each other.
- (4) The unlike poles of both magnets attract each other.

28. The diagram below shows a magnet is used to separate objects Q and R.



Which of the following materials are most likely to be Q and R?

	Q	R
(1)	plastic	aluminium
(2)	iron	plastic
(3)	aluminium	iron
(4)	iron	steel

END OF BOOKLET A



RED SWASTIKA SCHOOL
2022 END OF YEAR EXAMINATION
SCIENCE

Name : _____ ()

Class : Primary 4 / _____

Date : 1 NOVEMBER 2022

BOOKLET B

12 Questions
44 Marks

In this booklet, you should have the following:

- (a) Page 22 to Page 37
- (b) Questions 29 to 41

MARKS

	OBTAINED	POSSIBLE
BOOKLET A		56
BOOKLET B		44
TOTAL		100

Parent's Signature : _____

Answer all the questions in the space provided.

29. The diagram below shows a caterpillar.

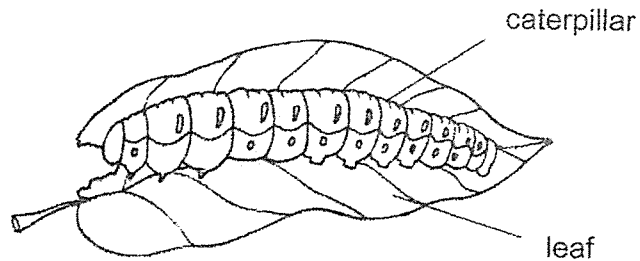

(a) The caterpillar needs air, food and _____ to survive. (1m)

(b) The caterpillar eats leaves and becomes bigger after some time.

This shows that it can _____ (1m)

30. The diagram below shows the human digestive system.

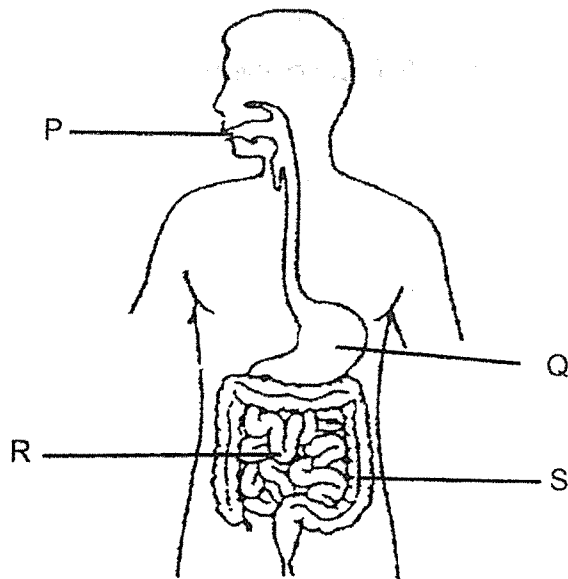

Identify the part (P, Q, R, S) where

(a) digestion is completed: _____ (1m)

(b) there is no digestion: _____ (1m)

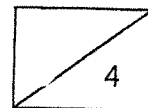

31. The diagram below shows the stages in the life cycle of a plant.



A



B

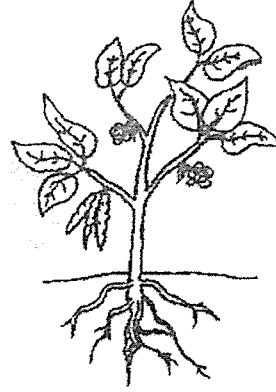

C

Choose the correct words from the box to answer the question below.

egg

seed

young plant

adult plant

Name the stages **A** and **B** in the life cycle of the plant. (2m)

A: _____

B: _____

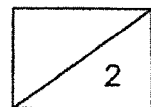

32. The diagram below shows how Hui Li sees the book.

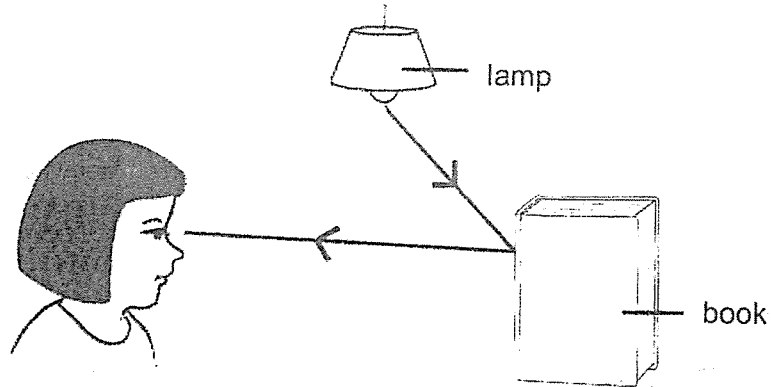

The _____ from the lamp is _____ by the book and enters Hui Li's eyes. (2m)

33. When end A of object Q is brought near a magnet as shown, the magnet moves away.

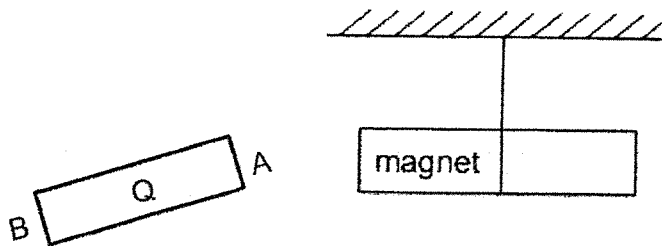

- (a) This shows that object Q is a _____. (1m)
- (b) When end B of object Q is brought near the magnet, it _____ the magnet. (1m)

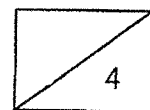

34. Study the animals shown.

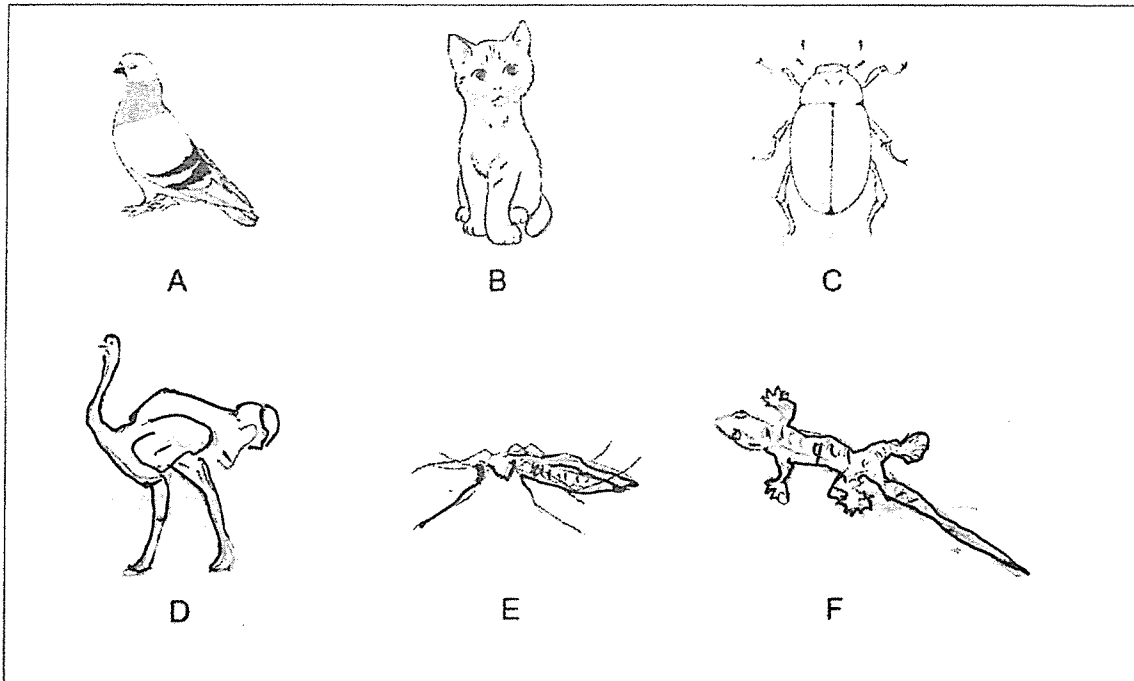

Isabel classified the animals into four groups as shown below.

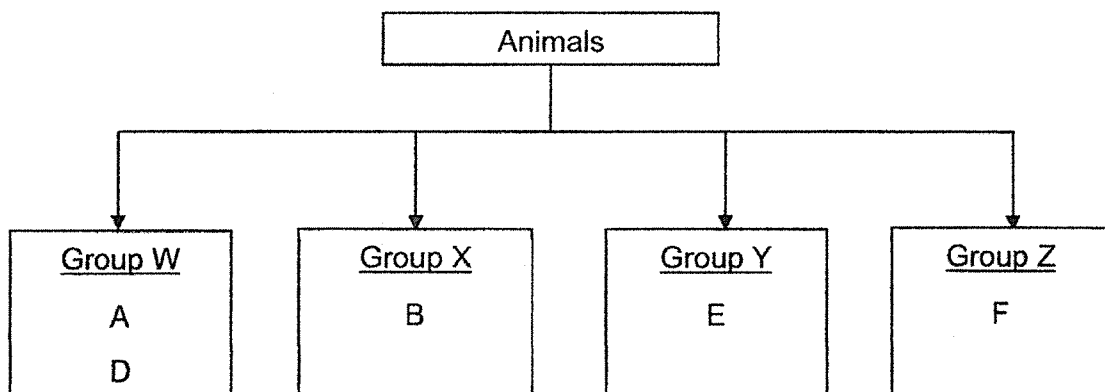

(a) In which group should animal C be placed in? (1m)

Group _____

(b) Write the heading of group W. (1m)

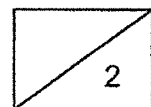

Isabel made the following observations about animal K:

- Lives in water
- Has short hair
- Breathes through lungs

(c) Based on the information given above, in which group, 'Fish' or 'Mammals', does animal K belong to? (1m)

(d) Explain your answer in (c). (2m)

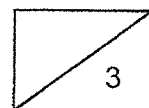

35. Aminesh observed the growth of the young plant shown below.

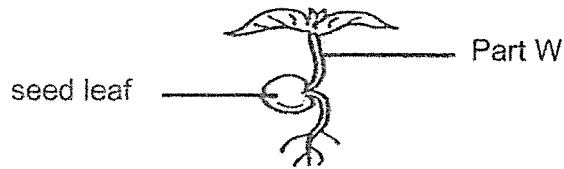

She plotted a graph to show the changes in the mass of its seed leaf over four days in a graph, as shown below.

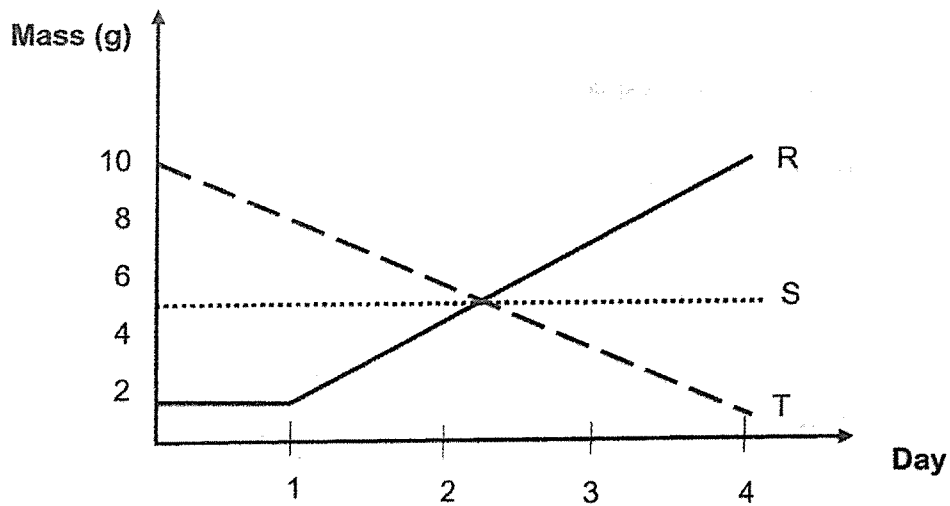

(a) Which line, R, S or T, best represents the mass of the seed leaf during the experiment? (1m)

(b) Give a reason for your answer in (a). (1m)

(c) Describe how the plant receives its food after day 4. (1m)

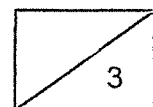

36. The diagrams below show the life cycle of animals P and Q.

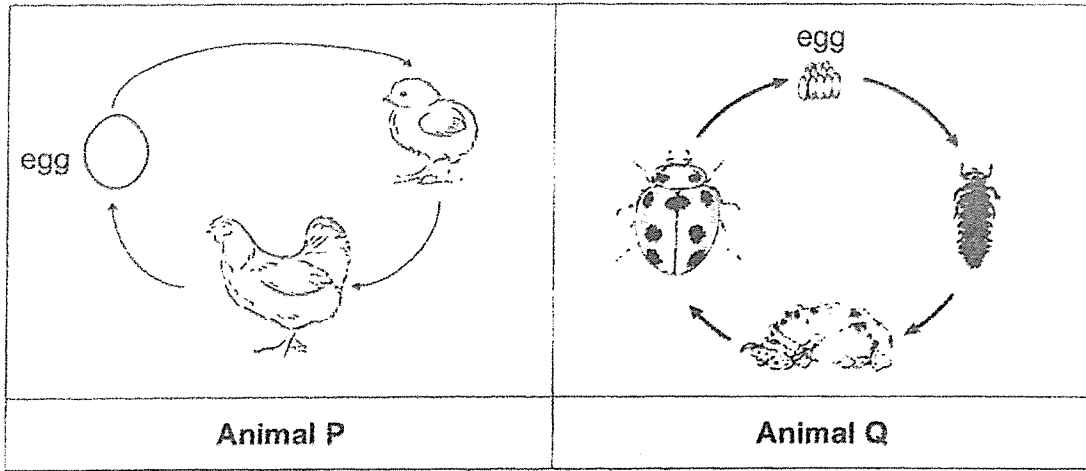

(a) Based on the above, state one similarity and one difference between the two life cycles. (2m)

Similarity: _____

Difference: _____

The graph below shows the amount of food eaten by animal Q during its life cycle.

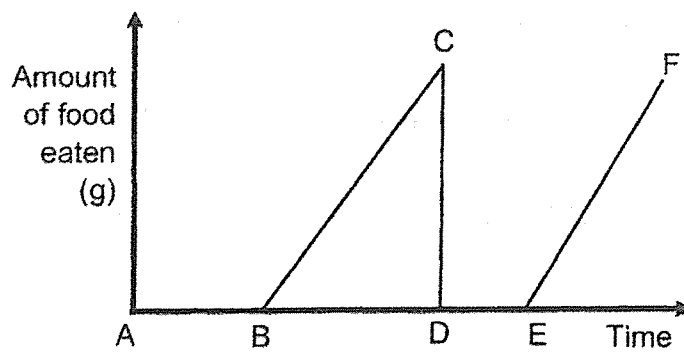

(b) Which part of the graph (BC or DE) represents the amount of food eaten by Q in the pupa stage? Give a reason for your answer. (2m)

37. Lily has three objects X, Y and Z as shown below.

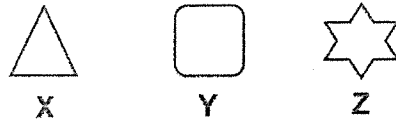

She placed the three objects into three similar containers, each containing the same amount of water, as shown below.

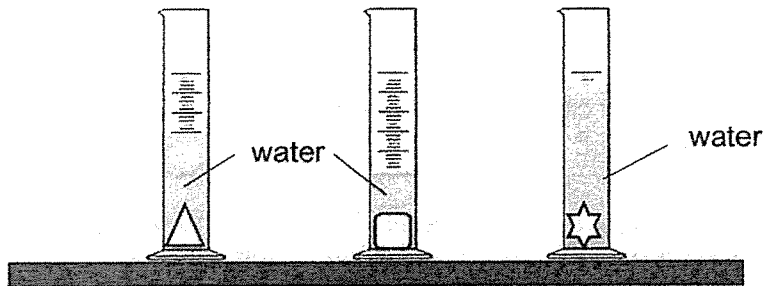

She compared the masses of the three objects using a lever balance as shown below.

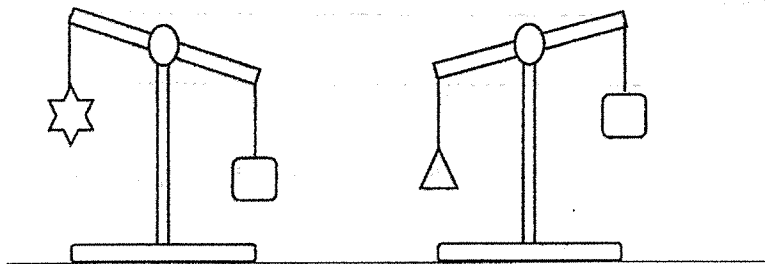

(a) Write the letters, X, Y or Z, in the table below. (2m)

Smallest volume	Smallest mass
(i)	(ii)

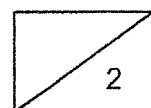

37. Lily placed nine identical balls into the container as shown in the diagram below. She poured 400 cm^3 of water into the container and she observed that some water flowed into the spaces between the balls.

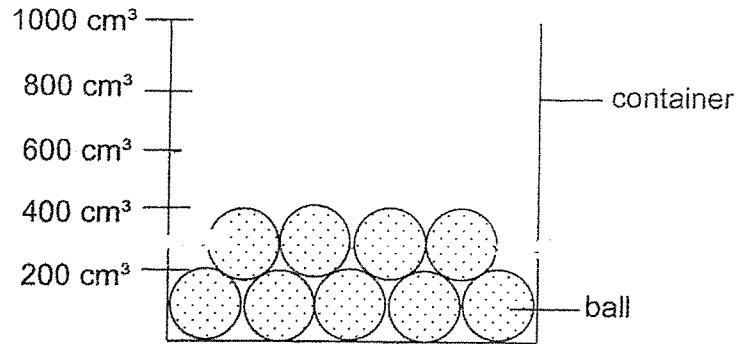

- (b) Name one property of water that enabled the water to be able to flow into the spaces between the balls. (1m)
-
- (c) **Using a pencil and a ruler**, draw the possible water level of the water in the container. (1m)
- (d) How can Lily find the volume of the nine balls? Put a tick (✓) in the box that shows the correct method. (1m)

Method	Description	Tick the correct option
A	Subtract 400 cm^3 of water from the final volume of both the water and the balls.	
B	Add 400 cm^3 of water to the final volume of both the water and the balls.	

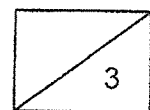

38. Charlie carried out an experiment in a dark room. Sheets P, Q and R were arranged in a straight line.

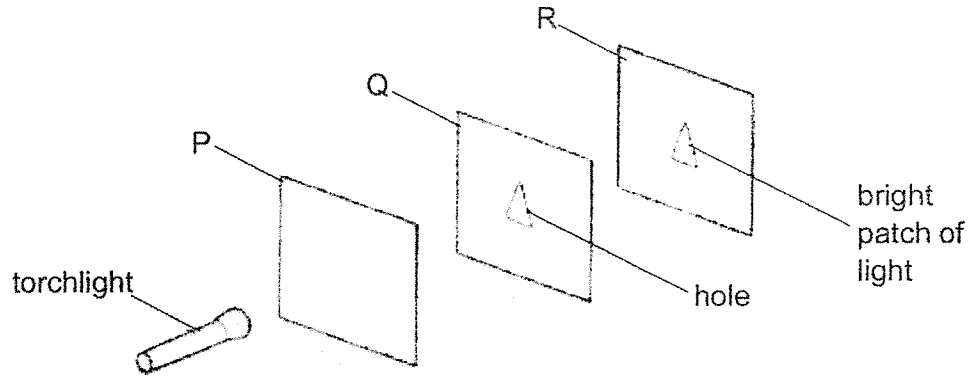

When the torch was switched on, a bright patch of light is seen on sheet R only

- (a) Put a tick (✓) in the table below to show the correct properties of sheets P and Q. (2m)

	Sheet	Does not allow light to pass through	Allows some light to pass through	Allows most light to pass through
(i)	P			
(ii)	Q			

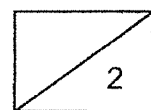

38. Jayan shone a torch on a wooden box as shown below. A shadow of the wooden box was formed on the screen.

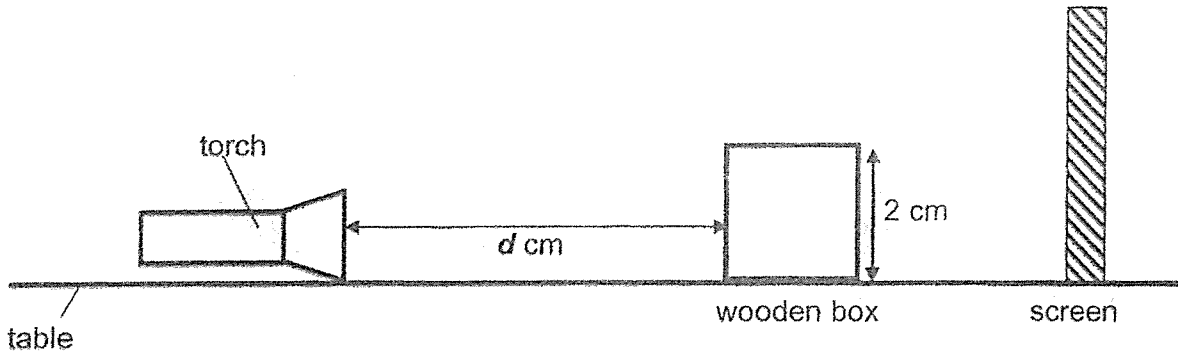

Jayan measured the height of the shadow formed on the screen as he moved the torch towards the wooden box. He recorded the results in the table as shown below.

Distance between torch and wooden box, d (cm)	Height of the shadow formed on the screen (cm)
10	3
8	4
6	6

- (b) How was the shadow formed? (1m)

- (c) What is the aim of the experiment? (1m)

- (d) Jayan used the same box in this experiment. State one other variable that he must keep constant. (1m)

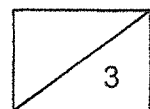

39. Sherman set up an experiment using two containers with different materials, X and Y as shown below. Both containers were sealed with a rubber stopper.

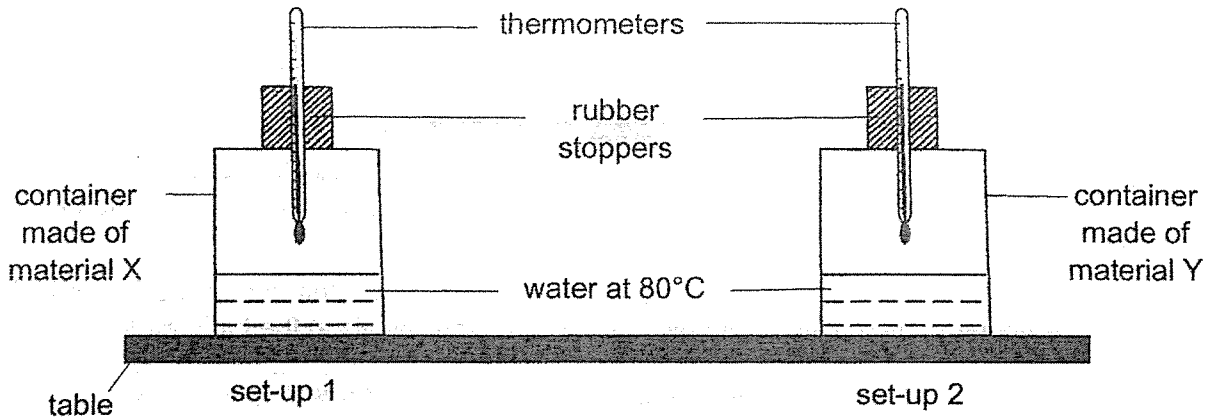

After 20 minutes, he recorded the temperature in the containers as shown in the table below.

Material of the container	Temperature in the container (°C)	
	Start of experiment	After 20 minutes
X	80	40
Y	80	60

- (a) Based on the experiment, which material (X or Y) is a better conductor of heat? (1m)

- (b) Explain your answer in (a). (1m)

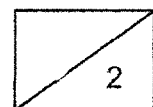

39. Sherman wants to use a cooler box to keep his packet drinks cold for a longer period of time.

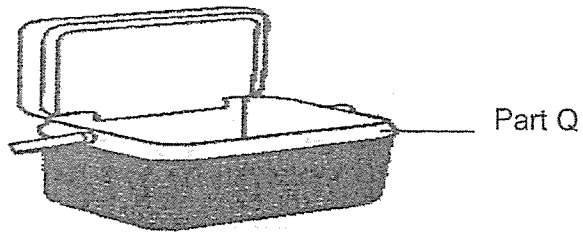

cooler box

- (c) Based on the results from the experiment, which material, X or Y, is more suitable to make part Q of the cooler box? (1m)

- (d) Explain your answer. (2m)

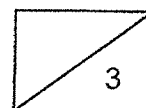

40. Desmond set up a light sensor and a light source as shown. He wanted to count the number of boxes moving on a belt. The boxes are similar in shape and size.

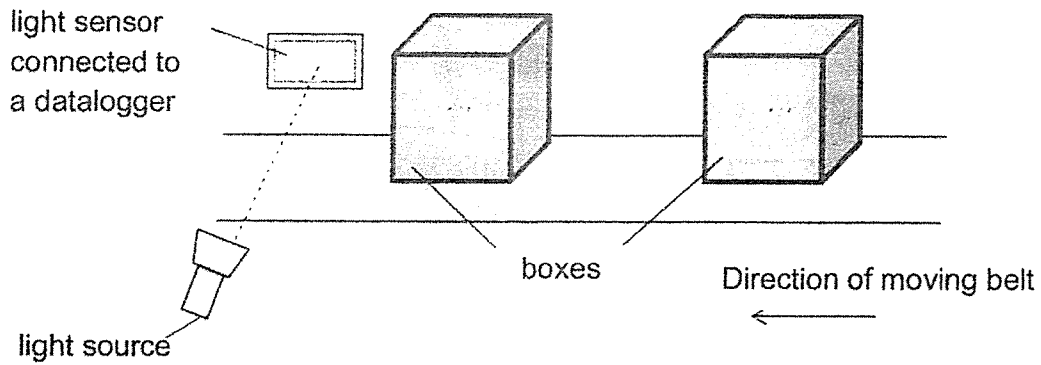

When the boxes moved past the light sensor, there would be a decrease in the amount of light detected. The following results were recorded by the datalogger.

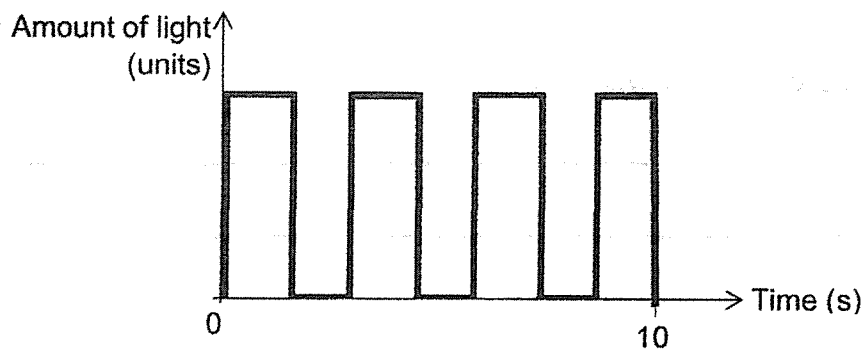

(a) Based on the above graph, how many boxes have moved past the light sensor in the first 10 seconds? (1m)

_____ boxes

(b) In order for the set-up to work, give an example of the material for the box.(1m)

(c) In order for the set-up to work, what property must the material in part (b) have? (1m)

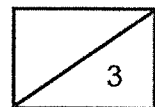

- 40 Desmond wanted to find out how the thickness of material can affect the amount of light passing through it. He carried out an investigation in a dark room as shown below.

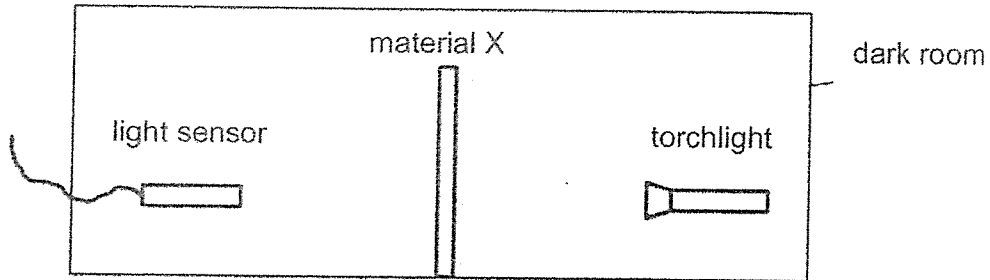

He placed material X between the light source and the light sensor and recorded the amount of light passing through it. He repeated the investigation using material X of different thickness and the results are shown in the table below. The amount of light recorded by the sensor without any material was 1000 units.

Thickness of Material X (mm)	Amount of light passing through (units)
2	600
4	450
8	250
16	50

- (d) State the relationship between the thickness of material X and the amount of light passing through it. (1m)

- (e) Desmond conducted the experiment in a dark room. Give a reason why this helped to make the experiment a fair test. (1m)

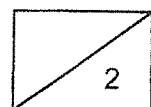

41. Rahman set up an experiment as shown below.

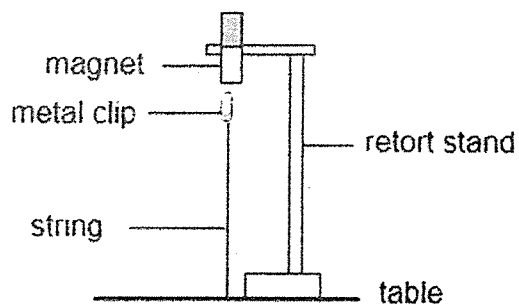

(a) Explain why the metal clip did not drop onto the table. (1m)

(b) When Rahman replaced the metal clip with a plastic clip, he observed that the plastic clip dropped onto the table immediately. Why did the plastic clip drop? (1m)

End of Booklet B

Please check your answers.

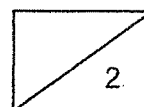

ANSWER KEY

YEAR : 2022
 LEVEL : Primary 4
 SCHOOL : RED SWASTIKA SCHOOL
 SUBJECT : SCIENCE
 TERM : End of Year Examination

Booklet A

Q1	3	Q2	2	Q3	1	Q4	4	Q5	2
Q6	4	Q7	2	Q8	1	Q9	3	Q10	3
Q11	2	Q12	4	Q13	1	Q14	1	Q15	1
Q16	4	Q17	2	Q18	3	Q19	4	Q20	1
Q21	3	Q22	3	Q23	2	Q24	4	Q25	2
Q26	3	Q27	4	Q28	2				

Booklet B

Q29	(a) water (b) grow
Q30	(a) R (b) S
Q31	A : seed B : young plant
Q32	light, reflected
Q33	(a) magnet (b) attracted
Q34	(a) Y (b) birds (c) mamals mammals (d) Mammals breathes through lungs, has short hair and can live in water.
Q35	(a) T (b) The food stored in the seed leaves is used up by the plant everyday till it has no more food thus T is the mass of the seed leaf. (c) The plant developed leaves and the leaves make food for the plants.
Q36	(a) Similarity : Both life cycles starts with an egg. Difference : Animal P has a three stage life cycle while animal Q has a four stage life cycle.

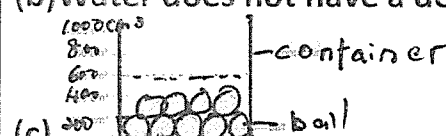
	(b) DE. No food is consumed during the pupa stage thus since DE has 0 food eaten it is the pupa stage.
Q37	<p>(a)(i) Y (ii) Z (b) Water does not have a definite shape.</p>  <p>(c) Method B A</p>
Q38	<p>(a)(i) Tick : Allows most light to pass through (ii) Tick : Does not allow light to pass through (b) When the path of light is blocked by an opaque object. (c) To find out if the distance of the torch and the wooden box affects the height of the shadow formed on the screen. (d) The size of the wooden box.</p>
Q39	<p>(a) X (b) X based on the table, the temperature of the water after twenty minutes is lower than Y. This shows that X is a better conductor of heat which conducts heat in the container to the surroundings at a faster rate. (c) Y (d) Y's temperature after 20 minutes is higher, this shows that Y is a poorer conductor of heat so it will be more suitable to be the material of a cooler bag as heat from the surrounding will take a longer time to be conducted to the packet drinks, keeping it cooler for a longer period of time.</p>
Q40	<p>(a) 3 (b) The box can be cardboard. (c) It does not allow light to pass through. (d) The thicker the material, the lesser the amount of light passing through. (e) It is so that the torchlight is the only light source the light sensor is sensing to ensure a fair test.</p>
Q41	<p>(a) The magnet is attracting the metal clip since the metal clip is a magnetic material. (b) The plastic clip is a non-magnetic material and will not be attracted by the magnet.</p>