

**RAFFLES GIRLS' PRIMARY SCHOOL  
END-OF-YEAR EXAMINATION  
PRIMARY FOUR  
2022**

**SCIENCE  
(BOOKLET A)**

Name: \_\_\_\_\_ (    )

Date : 27 October 2022

Class: P4 \_\_\_\_\_

Total Time: 1h 30min

**INSTRUCTIONS TO CANDIDATES**

1. Write your name, class and index number in the spaces provided above.
2. Do not turn over this page until you are told to do so.
3. Follow all instructions carefully.
4. Answer all questions.
5. For Question 1- 25, use 2B pencil to shade your answers on the Optical Answer Sheet (OAS).

Booklet A	50
Booklet B	40
Your score out of 90	
Parent's signature	



1. The leaf of plant A folds up when touched.

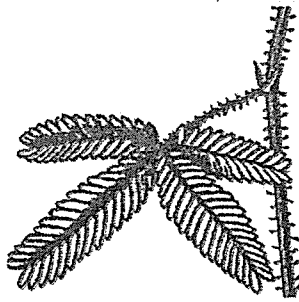

Plant A

This shows that plant A is a living thing because it can \_\_\_\_\_.

- (1) die
- (2) grow
- (3) respond
- (4) reproduce

2. Which of the following is not a mammal?

(1)

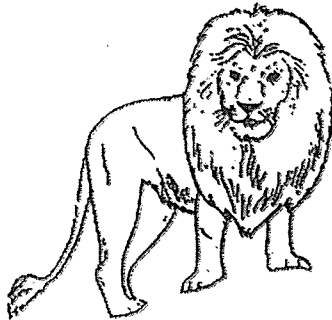

(2)

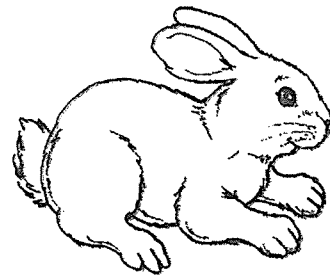

(3)

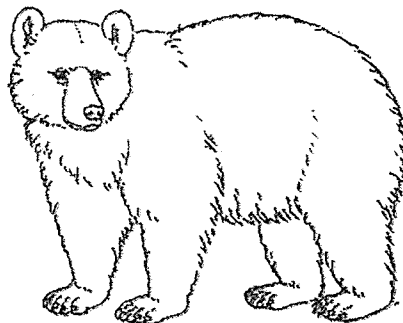

(4)

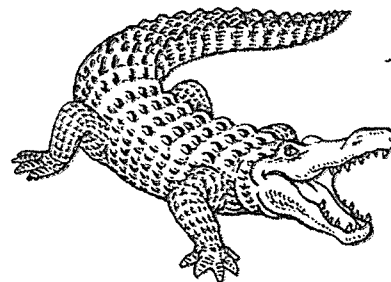

3. Which animal has a 3-stage life cycle?

(1)

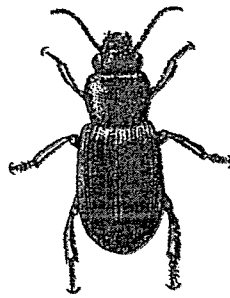

Beetle

(2)

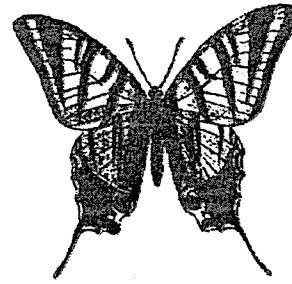

Butterfly

(3)

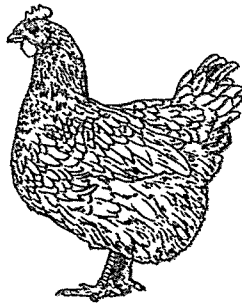

Hen

(4)

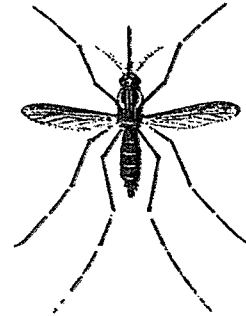

Mosquito

4. The diagram shows the life cycle of a plant.

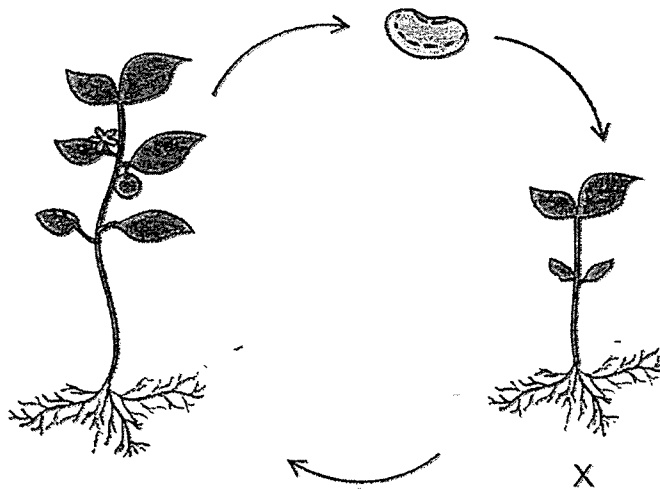

What is the stage marked X?

- (1) Egg
- (2) Seed
- (3) Adult plant
- (4) Young plant

5. In which part of the digestive system is food absorbed into the blood?

- (1) Mouth
- (2) Stomach
- (3) Large intestine
- (4) Small intestine

6. The diagram shows a screwdriver.

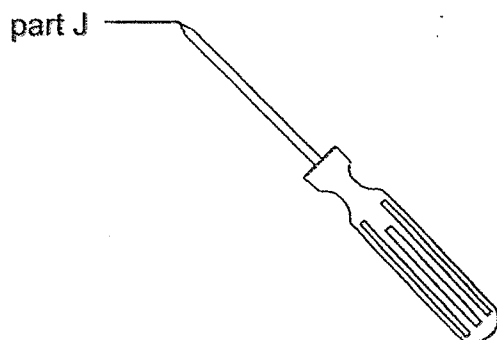

Metal is used to make part J because metal \_\_\_\_\_.

- (1) can reflect light
  - (2) does not break easily
  - (3) can bend without breaking
  - (4) allows light to pass through
7. Which of the following properties is true for both air and milk?
- (1) They can be seen.
  - (2) They take up space.
  - (3) They have fixed shapes.
  - (4) They have fixed volume.

8. Which one of the following is a source of light?

(1)



The moon

(2)

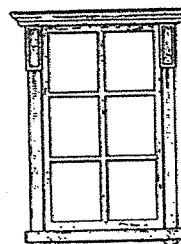

A window

(3)

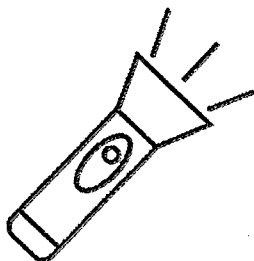

A lit torch

(4)

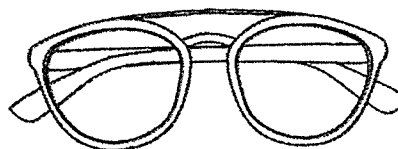

A pair of glasses

9. Which one of the following is not a source of heat?

- (1) A lighted lamp
- (2) A toaster oven
- (3) A candle flame
- (4) A woollen sock

10. Object A was attracted to the magnet as shown in the diagram.

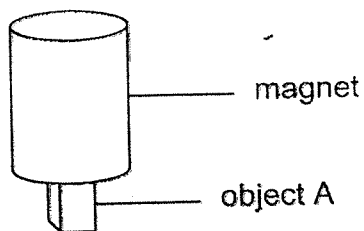

Object A is made of \_\_\_\_\_.

- (1) iron
- (2) glass
- (3) paper
- (4) cotton

11. The diagram shows the life cycle of a plant.

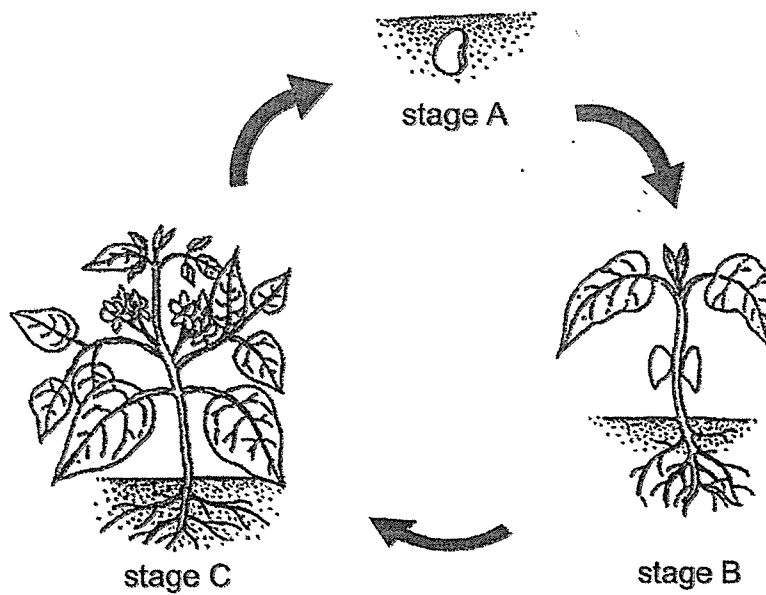

Which of the following statement(s) about the life cycle of the plant is/are correct?

- A The plant can make food at stage A.
- B The roots absorb food for the plant at stage C.
- C The roots absorb water for the plant at stage C.
- D The seed leaves provide food for the plant at stage B.

- (1) C only
- (2) D only
- (3) B and C only
- (4) A and D only

12. Sally observed three animals, W, X and Y, and recorded her observations in the table.

A tick (✓) indicates the presence of the observation.

Animal	Observations		
	It has four stages in its life cycle	The young resembles (looks like) the adult	It lays eggs
W	✓		✓
X		✓	✓
Y		✓	✓

Which of the following best represents these animals?

	Animal W	Animal X	Animal Y
(1)	Butterfly	Chicken	Mosquito
(2)	Butterfly	Chicken	Cockroach
(3)	Chicken	Butterfly	Cockroach
(4)	Mosquito	Butterfly	Chicken



13. The flowchart shows the characteristics of organs X, Y and Z of the human digestive system.

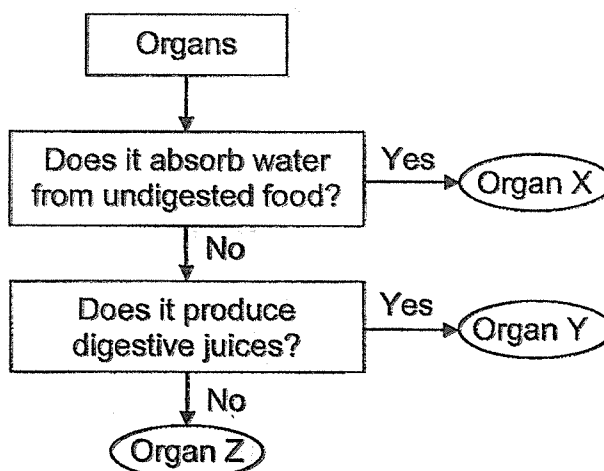

Identify organs X, Y and Z.

	Organ X	Organ Y	Organ Z
(1)	Stomach	Large intestine	Gullet
(2)	Large intestine	Stomach	Gullet
(3)	Small intestine	Gullet	Stomach
(4)	Stomach	Gullet	Small intestine

14. The diagram shows a young plant.

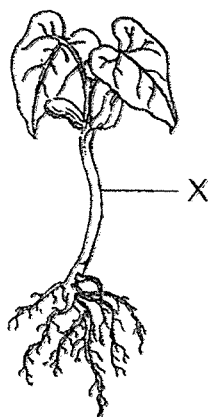

Part X helps the young plant to \_\_\_\_\_.

- (1) make food
- (2) absorb water
- (3) stand upright
- (4) take in and give out air

15. Stacy removed the roots of a plant. She placed the plant into a beaker of red-coloured water as shown in the diagram next to a window for two days. Part of the stem was damaged and only flower N was stained red.

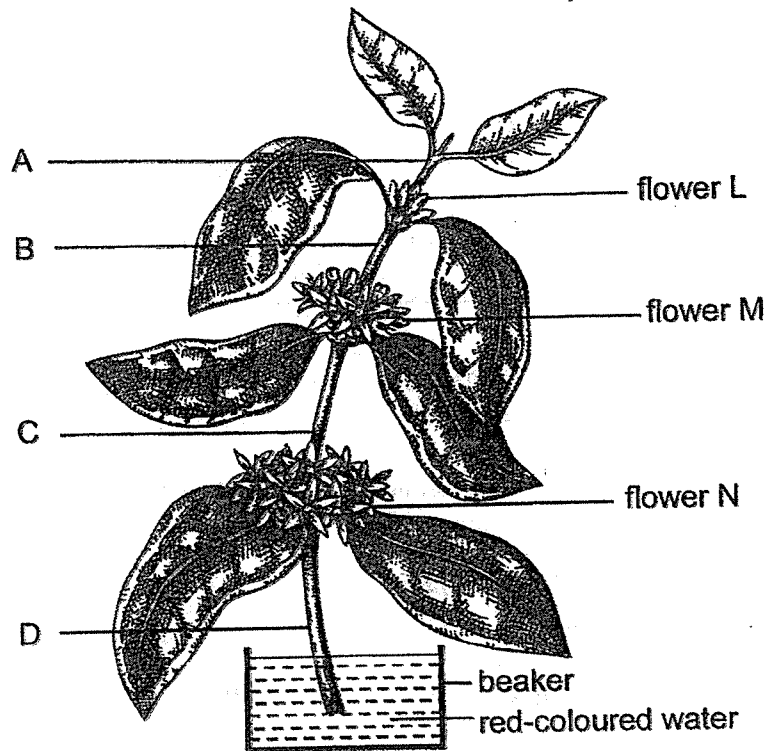

Which part of the stem, A, B, C or D, was damaged?

- (1) A
- (2) B
- (3) C
- (4) D

16. Kim filled two identical syringes, A and B, with different substances of the same amount. The tips of the syringes were sealed as shown in the diagram.

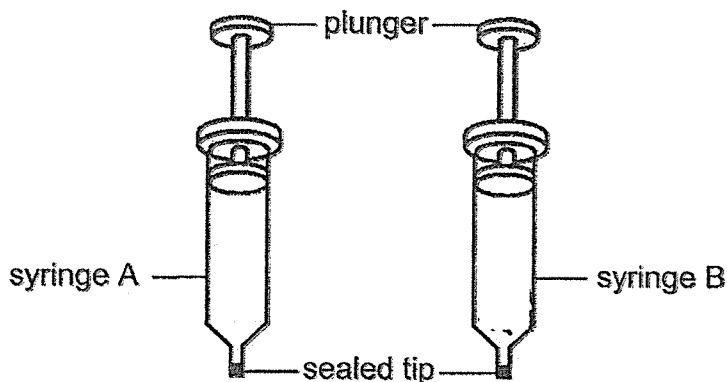

She pressed down both plungers and observed that the plunger of the syringe A could be pushed down while the plunger of syringe B could not be pushed down.

Which of the following is most likely to be the substances in syringes A and B?

	Substance in syringe A	Substance in syringe B
(1)	Air	Marbles
(2)	Apple juice	Beads
(3)	Marbles	Apple juice
(4)	Beads	Air

17. Beaker A is filled with pebbles as shown in the diagram. When water from beaker B is poured into beaker A, George observed that the water does not overflow in beaker A.

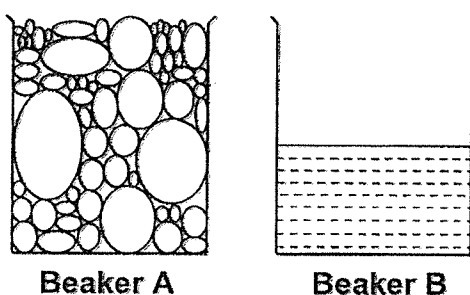

Which of the following shows the correct explanation for his observation?

- (1) The pebbles in the beaker A have a definite mass.
- (2) Water from beaker B does not have a definite volume.
- (3) The pebbles in beaker A took the place of water from beaker B.
- (4) Water from beaker B occupied the space in between the pebbles in beaker A.

18. The diagram shows a boy looking at a picture.

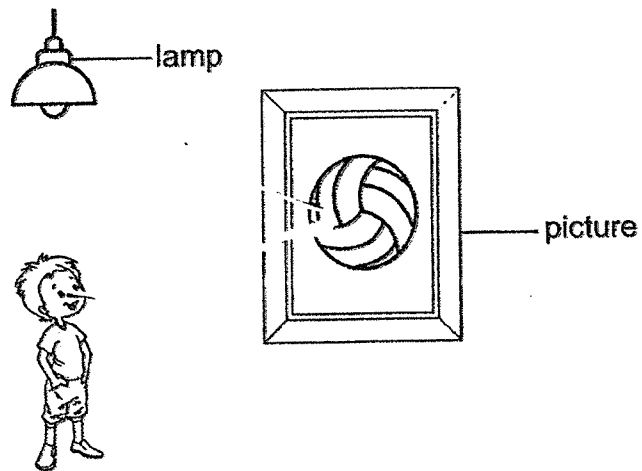

Which of the following correctly shows how the boy can see the picture?

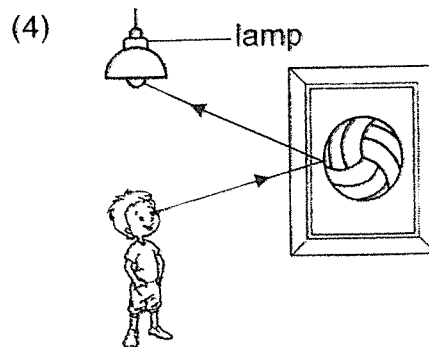
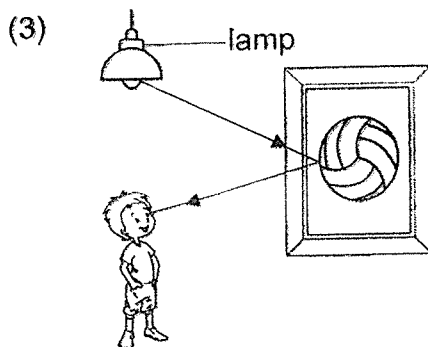
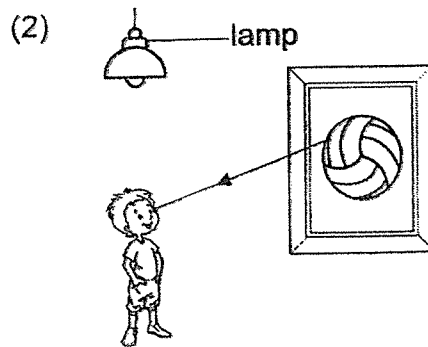
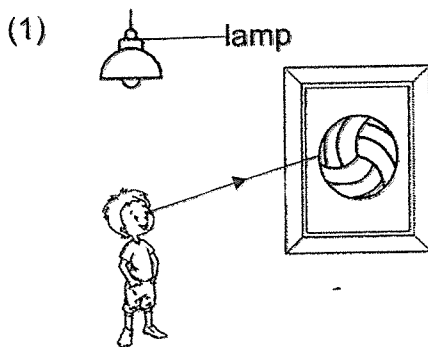
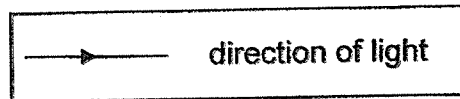

19. Alan prepared a set-up as shown in the diagram to measure the amount of light that passed through a sheet of material X in a dark room.

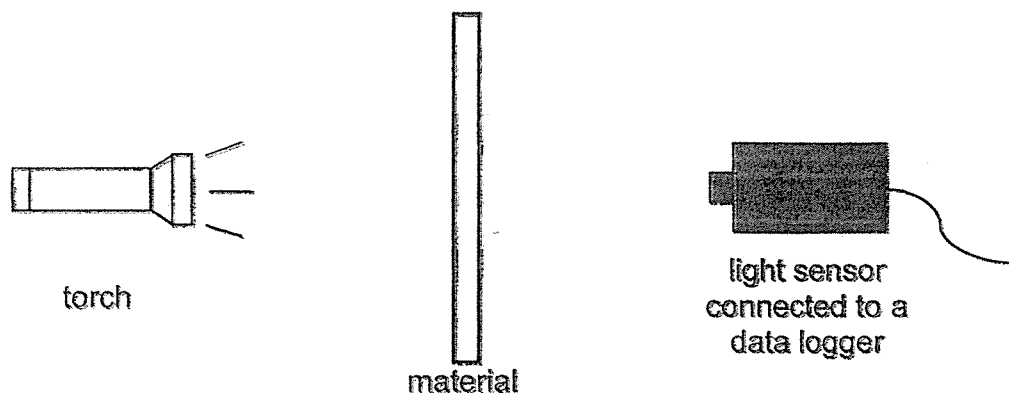

Alan replaced the sheet of material X with sheets Y and Z of the same size and thickness, one at a time.

He recorded the amount of light detected by the light sensor in the table below. The amount of light from the torch was 1300 lux.

Materials	Amount of light passing through (lux)
X	1100
Y	0
Z	400

Using the information from the table, which of the following correctly represents materials X, Y and Z?

	X	Y	Z
(1)	Clear plastic	Wood	Tracing paper
(2)	Wood	Clear plastic	Tracing paper
(3)	Clear plastic	Tracing paper	Wood
(4)	Tracing paper	Clear plastic	Wood

20. Jason prepared an experimental set-up using three shapes X, Y and Z made of different materials as shown in the diagram. He shone a lighted torch on the shapes and observed the shadow on the screen.

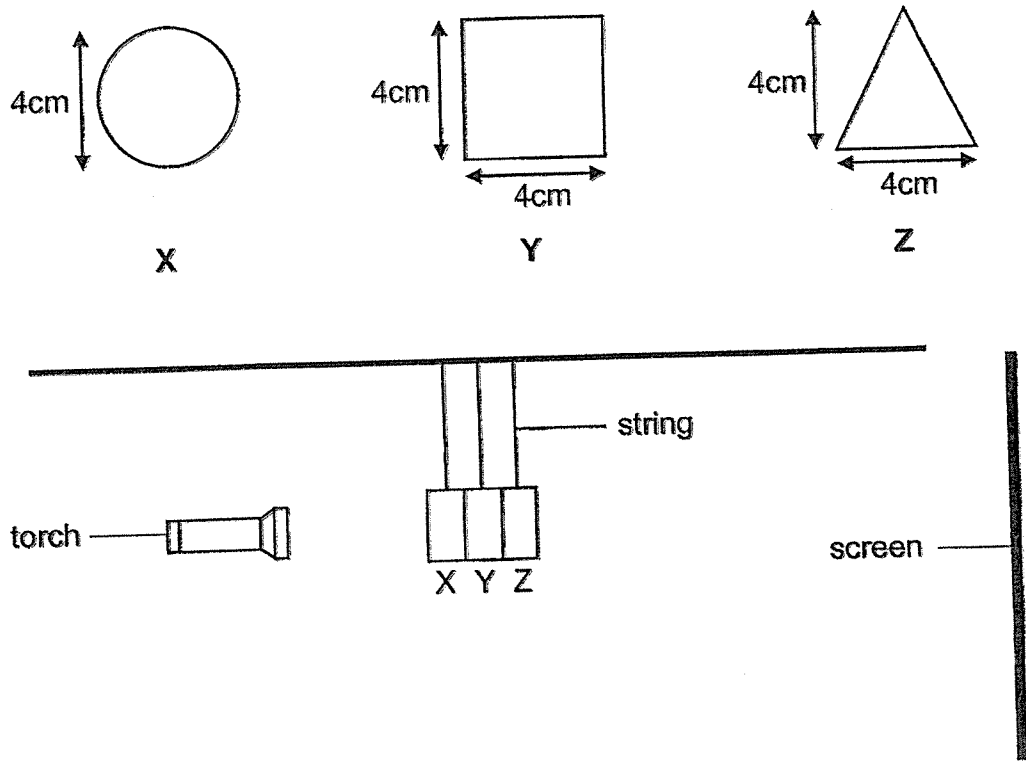

The shadow observed on the screen is as shown below.

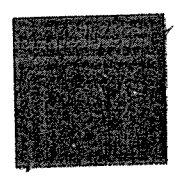

Based on the observation of the shadow, which of the following best describes the amount of light passing through shapes X, Y and Z?

	X	Y	Z
(1)	Allow most light to pass through	Allow some light to pass through	Does not allow any light to pass through
(2)	Allow some light to pass through	Not possible to tell	Does not allow any light to pass through
(3)	Does not allow any light to pass through	Allow some light to pass through	Allow most light to pass through
(4)	Allow most light to pass through	Does not allow any light to pass through	Not possible to tell

21. Which of the following is true about temperature?

- (1) Temperature is a form of energy.
- (2) Temperature is the degree of hotness of an object.
- (3) Temperature is the amount of hotness of an object.
- (4) Temperature of object increases and the object will contract.

22. George boiled some water in container A as shown in the diagram.

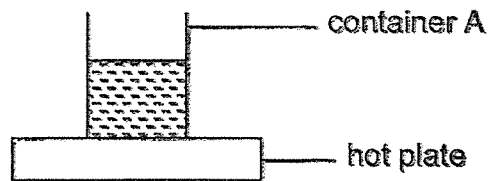

He repeated his experiment using identical containers, B and C, using different amounts of water each time. He recorded the time taken for the water to boil in each container in the bar chart.

Time taken for  
water to boil (minute)

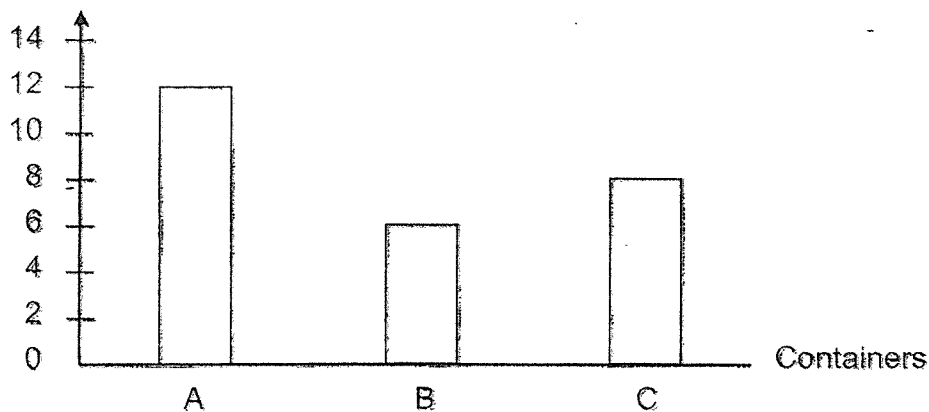

Based on the results of his experiment, which of the following is correct?

- (1) Container B contained the least amount of water.
- (2) The temperature of water in container A rose the fastest.
- (3) The water in container A gained heat the fastest from the hot plate.
- (4) The water in all the containers had the same amount of heat when they started to boil.

23. Study the set-up as shown in the diagram.

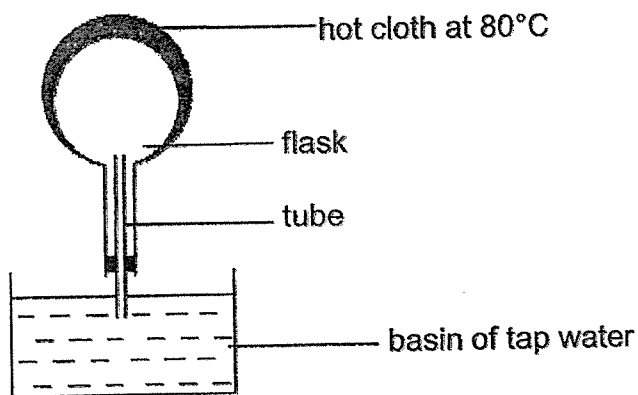

Which of the following statement(s) is/are true?

- A Air bubbles are seen at the mouth of the tube in the water.
- B The hot cloth gains heat from the surrounding air.
- C The air in the flask gains heat from the cloth.
- D Water loses heat to the air in the flask.

- (1) A only
- (2) D only
- (3) A and C only
- (4) B and D only

24. Farah made electromagnets from four similar iron bars, P, Q, R and S using different number of coils of wire and batteries as shown in the table.

Iron bar	Number of coils of wire around the nail	Number of batteries used
P	15	1
Q	5	1
R	20	2
S	20	1

She then placed the electromagnets, one at a time, near four similar boxes of paper clips. Which of the following statements is most likely to be correct?

- (1) Iron bar Q has the weakest magnetic strength.
- (2) Iron bar S has the strongest magnetic strength.
- (3) Iron bar P attracts more paper clips than iron bar R.
- (4) Iron bar P and Q will attract the same number of paper clips.



25. A mixture of materials moves through a moving belt fitted with a strong magnet. The materials will then be separated into two groups, A and B, as shown.

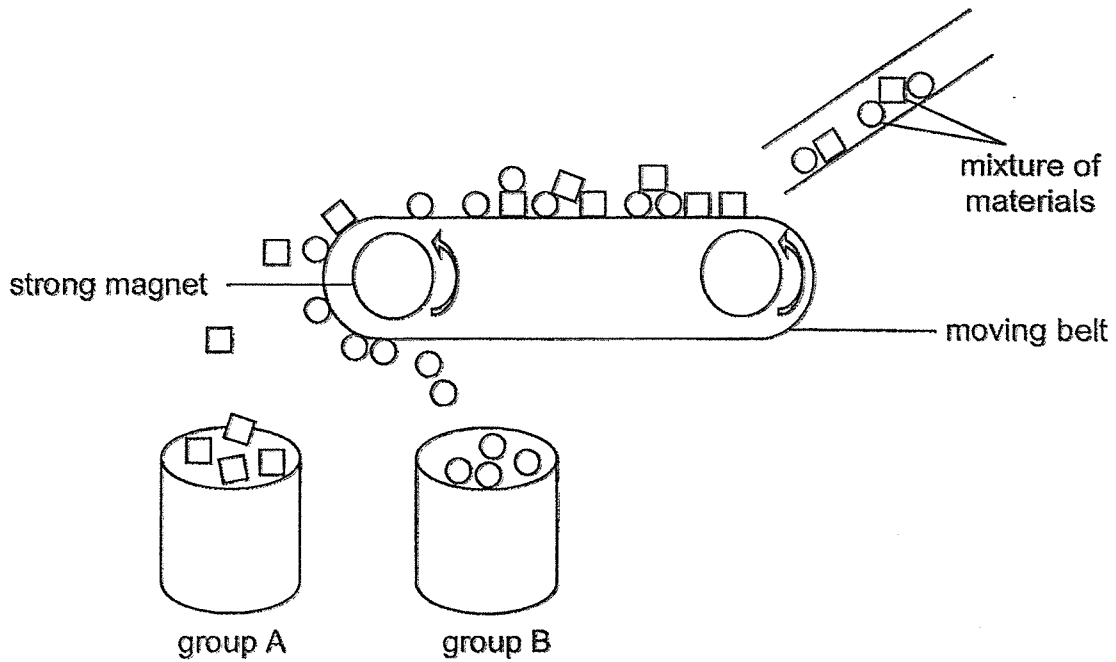

Which of the following is most likely to be correct?

- (1) Group A contains materials made of aluminium.
- (2) Group B contains materials that are non-metallic.
- (3) Group A contains materials that can be made into a magnet.
- (4) Group B contains materials that cannot be attracted by the magnet.

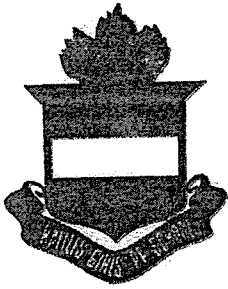

**RAFFLES GIRLS' PRIMARY SCHOOL  
END-OF-YEAR EXAMINATION  
PRIMARY FOUR  
2022**

**SCIENCE  
(BOOKLET B)**

Name: \_\_\_\_\_ ( )

Date : 27 October 2022

Class: P4 \_\_\_\_\_

Total Time : 1h 30min

**INSTRUCTIONS TO CANDIDATES**

1. Write your name, class and index number in the spaces provided above.
2. Do not turn over this page until you are told to do so.
3. Follow all instructions carefully.
4. Answer all questions.
5. For questions 26 – 37, write your answers clearly in the spaces provided.
6. The number of marks is shown in brackets [ ] at the end of each question or part question.

Score	40
-------	----

26. (a) The diagram shows part of the human digestive system. Tick one box to show where the gullet is. [1]

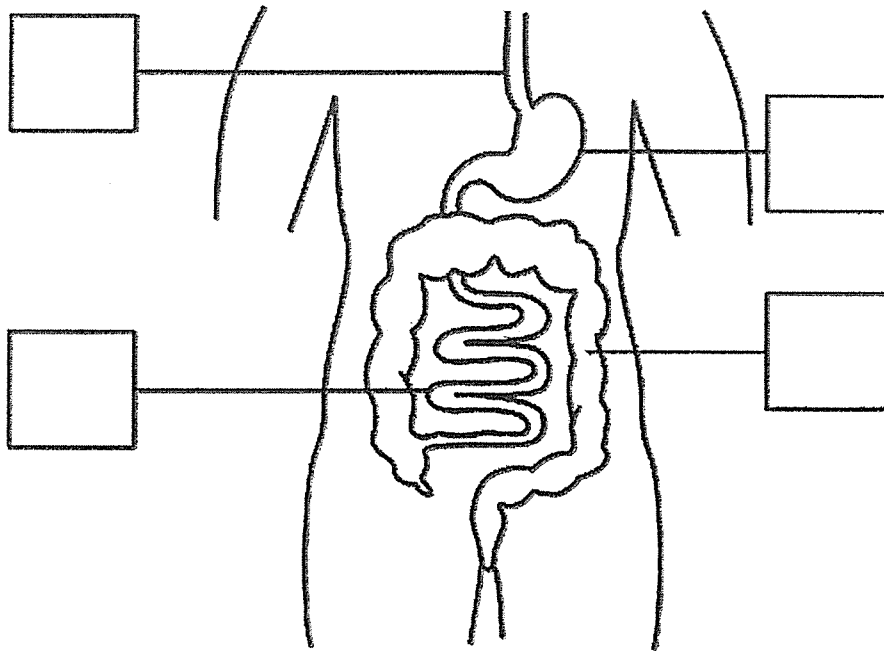

- (b) Fill in the blank using the following helping words. [1]

large intestine	stomach	small intestine	mouth
-----------------	---------	-----------------	-------

Food from the gullet is next passed on to the \_\_\_\_\_.

Score	2
-------	---

27. (a) Fill in the correct parts of a plant in the table. [2]

Function of plant part	Plant part
It helps the plant to make food.	(i)
It holds the plant upright.	(ii)

(b) Jason conducted an experiment with two set-ups, X and Y, using identical plants, as shown in the diagram. Most of the roots in set-up Y have been removed.

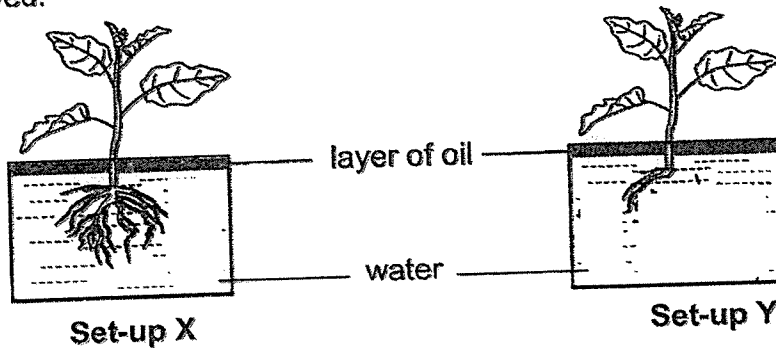

Both set-ups were left near an open window for two days.

(i) In which set-up would the water level be lower after two days? Explain your answer. [2]

---



---

The plant in set-up X was accidentally broken as shown in the diagram.

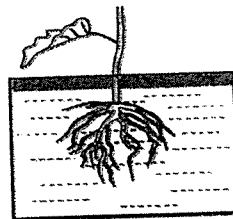

(ii) Would the plant shown above still survive? Explain your answer. [1]

---



---

Score	5
-------	---

- 28. Bala compared the mass of three objects.

Study the diagrams below and circle the correct comparisons.

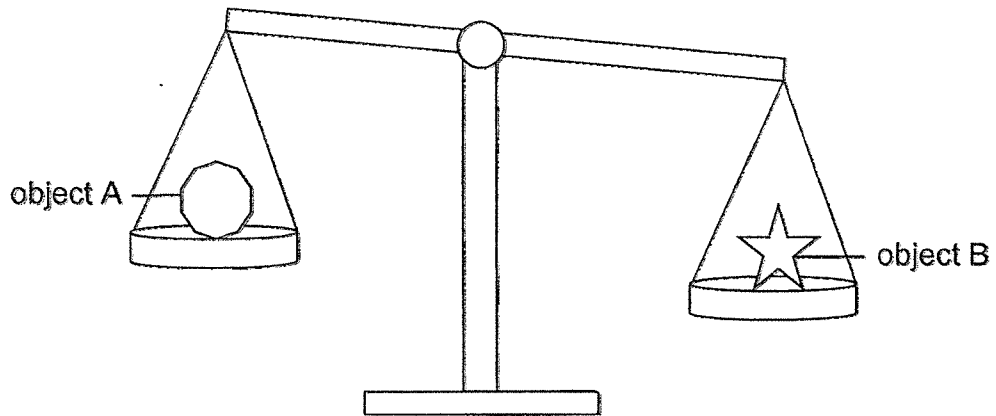

- (a) Object A is lighter than / has the same mass as / is heavier than object B. [1]

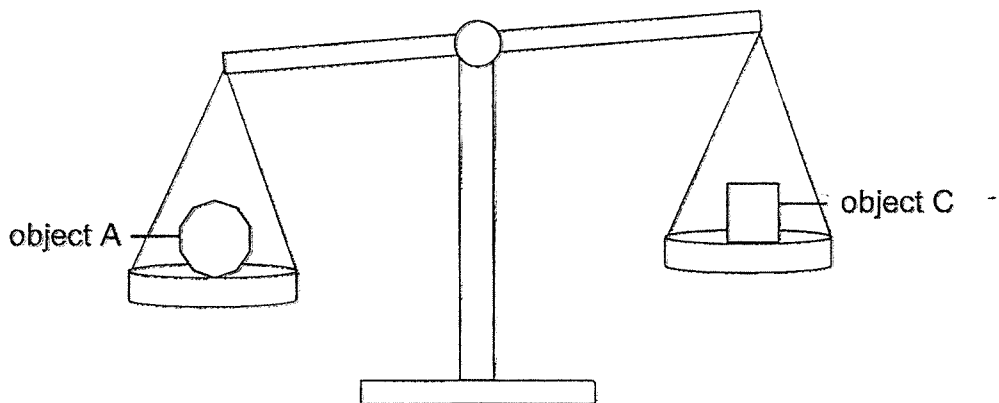

- (b) Object A is lighter than / has the same mass as / is heavier than object C. [1]

Score	2
-------	---

29. Jann placed a metal and a glass rod into a tank of boiling water. Identical pieces of ice cubes were placed on both rods as shown.

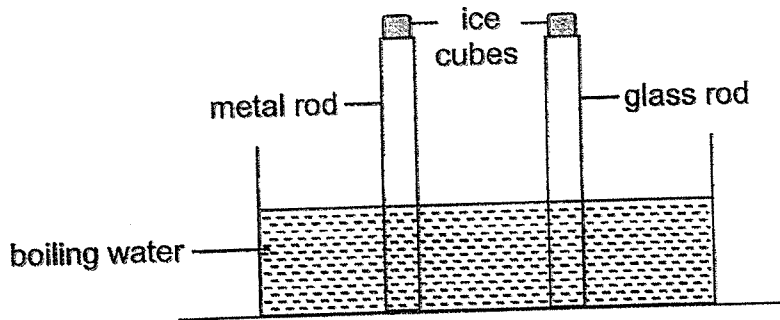

What would Jann observe and why? [2]

The ice cube on the glass rod melts \_\_\_\_\_ than the ice cube on the metal rod as glass is a \_\_\_\_\_ conductor of heat than metal.

30. Two magnets were placed together through a plastic holder as shown.

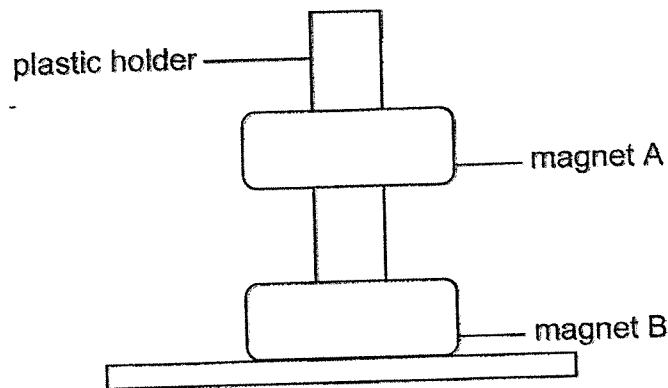

- (a) The holder was made of plastic and did not attract the magnet. [1]

Plastic is a \_\_\_\_\_ material.

- (b) Why was magnet A floating on top of magnet B? [1]

Magnet B was \_\_\_\_\_ magnet A.

Score	4
-------	---

31. The diagram shows a young seedling.

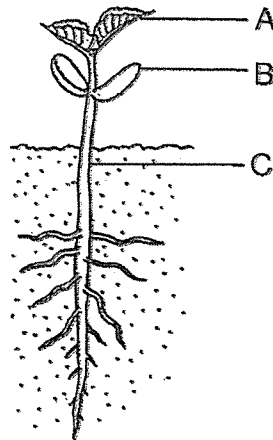

The mass of one part of the plant (A, B or C) was measured over eight days. The results were recorded in the table.

Day	Mass (g)
1	8
4	5
6	(b) _____
8	2

(a) Using the data from the table above, which part of the plant, A, B or C, was the mass being measured? Explain your answer. [2]

---

---

(b) What would be the mass of the plant part identified in your answer in (a) on day 6? Write your answer in the table above. [1]

Continue on page 21

Score	3
-------	---

Continued from page 20

Joshua prepared two set-ups as shown in the diagram. He left them in a dark room for a week.

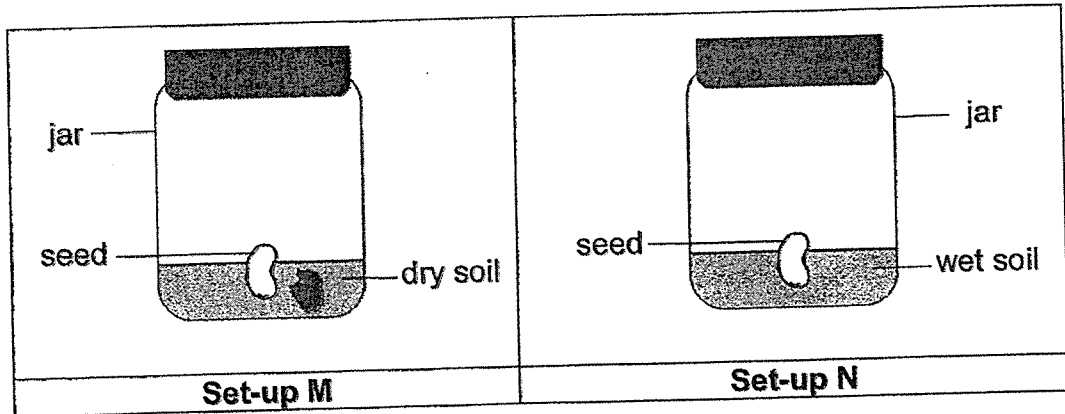

- (c) In which set-up would the seed germinate?  
Explain your answer.

[1]

---

---

Score	1
-------	---



32. Shawn wanted to find out if the size of the food affects the rate of digestion. He placed identical amount of food into three beakers as shown in the diagrams. He then placed digestive juice into the three beakers.

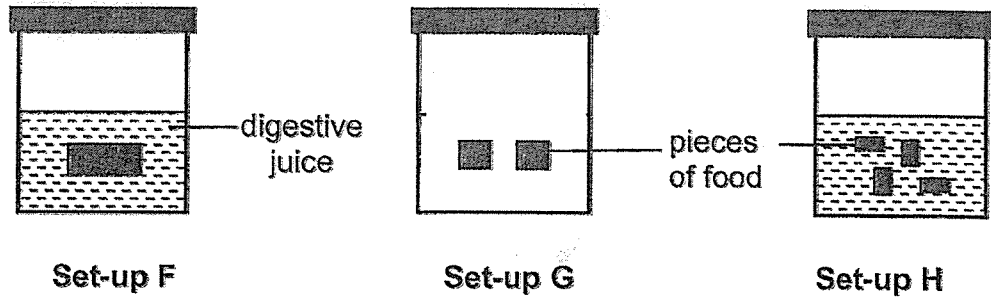

- (a) In the diagram above, draw a line in the beaker to show the correct amount of digestive juice Shawn had put in set-up G, in order to conduct a fair test. [1]

Shawn recorded the time taken for the food to be digested completely in the table.

Set-up	Time taken for digestion to complete (s)
F	150
G	(b) _____
H	100

- (b) What is likely to be the time taken to complete the digestion in set-up G? Write your answer in the table above. [1]
- (c) Explain your answer in (b) in comparison with set-up F. - [1]

---



---

Score	3
-------	---

33. Tony set up an experiment as shown in the diagrams to compare the property of four strips, A, B, C and D, which were made of different materials but of the same thickness.

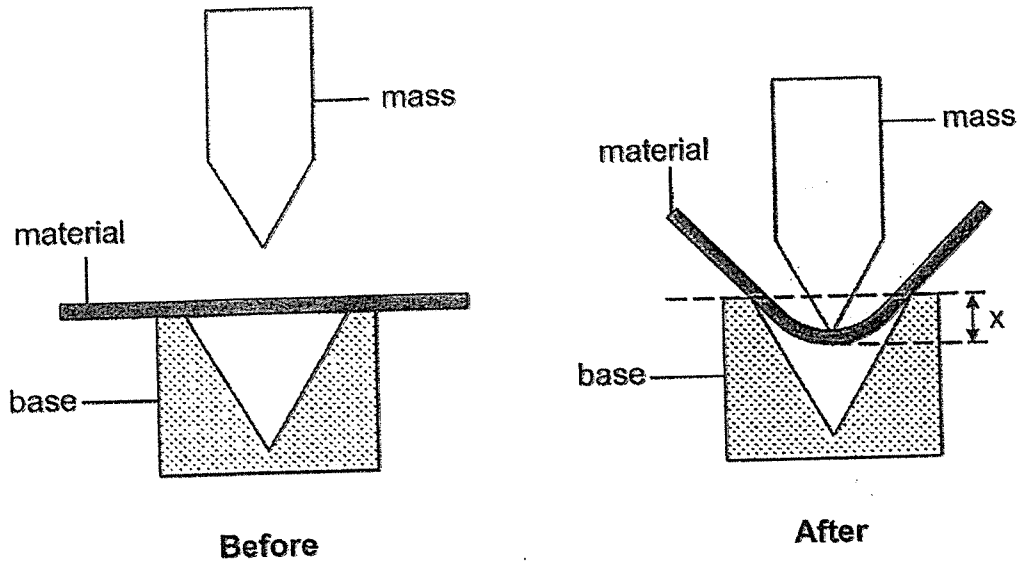

He attached the strip on a base and placed a mass on it as shown in the diagram above. He recorded the distance,  $x$ , in the table below.

Material	Distance $x$ (cm)
A	0
B	9
C	30
D	10

- (a) Based on the results, which strip, A, B, C or D, is most suitable for making a belt? Explain your answer. [2]

---



---

Continue on page 24

Score	2
-------	---

Continued from page 23

Tony then wanted to make a hook strong enough to hang a calendar on the wall. The calendar has a mass of 110g. He hung a strip of material E as shown in the diagram.

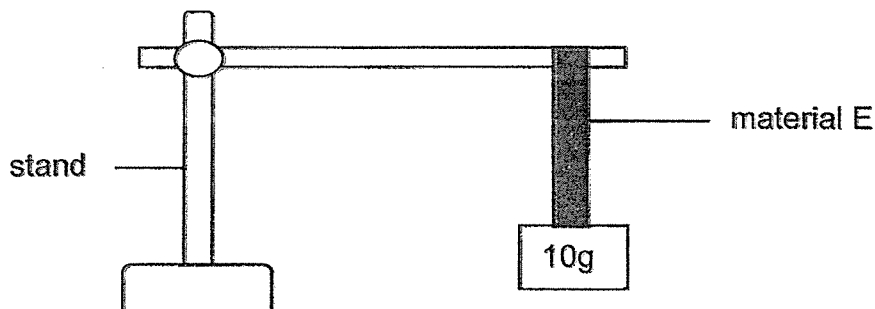

A 10g-mass was added one at a time to the end of the material E until the material started to break. Material E started to break when a 100g-mass was hung on it.

- (b) Tony said that material E is suitable to use to make the hook. Do you agree with him? Explain your answer. [2]

---

---

Score	2
-------	---

34. Calvin prepared an experiment set-up by placing a water dispenser which had an attached air pump on an electronic balance as shown in the diagram. He filled the water dispenser with some water and recorded the mass of the water dispenser.

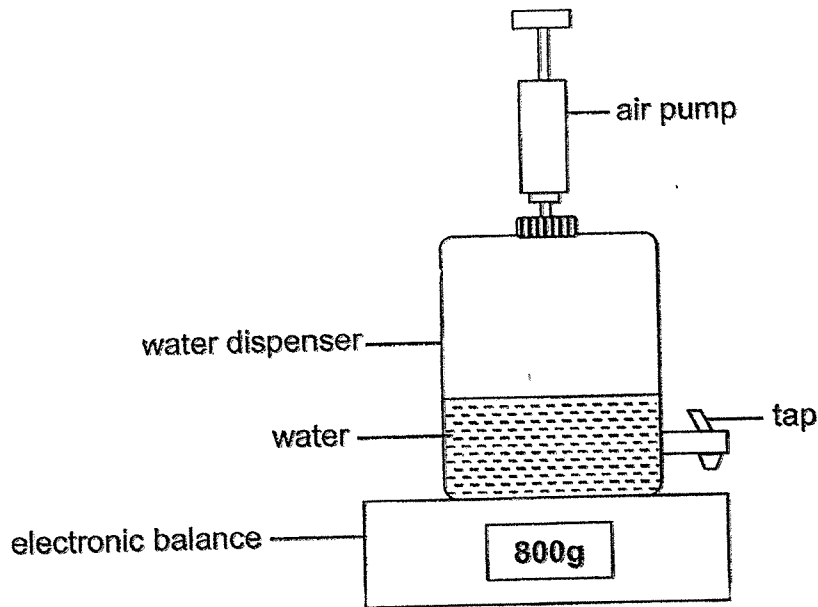

Then he pumped more air into the same water dispenser and recorded its mass again.

- (a) State what happened to the reading on the electronic balance after some air was pumped into the water dispenser. [1]

---

- (b) Give a reason for your answer in (a). [1]

---

---

- (c) Using the same set-up and without pumping in more air, suggest one way to increase the volume of air in the water dispenser filled with some water. Explain your answer. [2]

---

---

Score	4
-------	---

35. Jeremy conducted an experiment in a dark room to investigate the properties of materials P, Q, R and S. He placed different materials at positions 1 and 2 respectively each time.

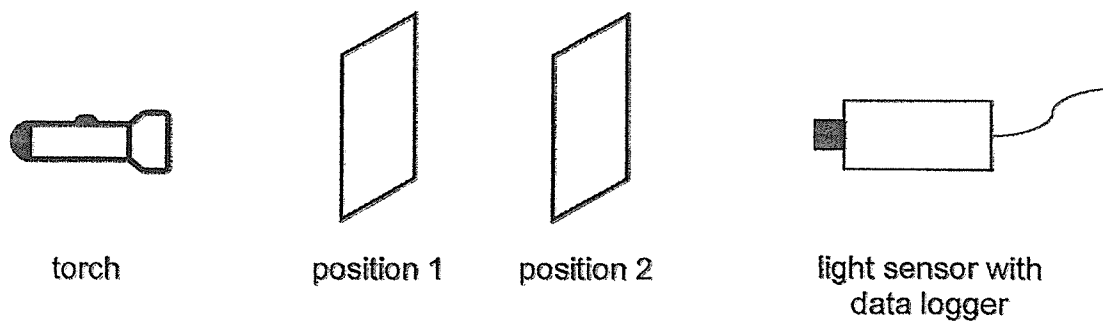

The amount of light detected by the light sensor was recorded as shown in the table.

Material at position 1	Material at position 2	Amount of light detected (lux)
P	Q	2000
Q	R	0
R	S	0
S	P	300

- (a) Using the information from the table, which one of the materials, P, Q, R or S, would be most suitable to make a bedroom curtain that keeps the room totally dark during the day? Explain your answer. [2]

---



---

- (b) Give a reason why Jeremy conducted the experiment in a dark room. [1]

---



---

Continue on page 27

Score	3
-------	---

Continued from page 26

The diagram shows a scanner that counts the number of people entering a concert hall. A light source and light sensor were placed on the scanner as shown. The light sensor detects the light coming from the light source.

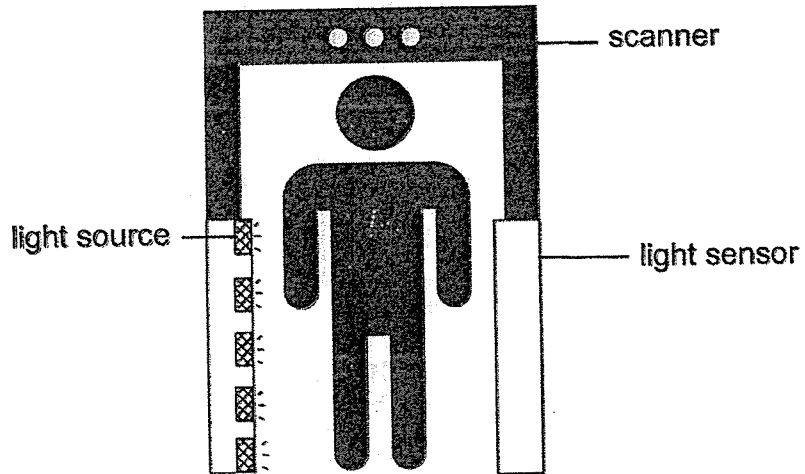

The scanner is only wide enough for one person to pass through at a time. The graph shows the readings from the light sensor.

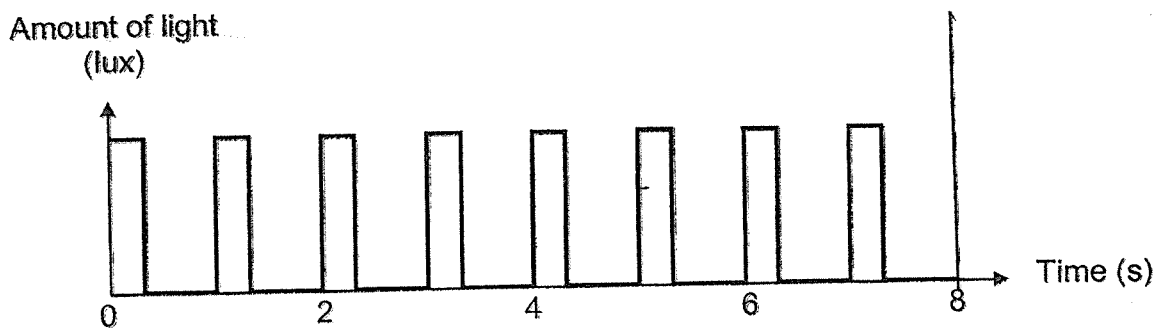

- (c) Based on the graph, how many people passed through the scanner within eight seconds? [1]

Score	1
-------	---

36. David filled two identical mugs with equal amounts of chocolate drink and milk with a temperature  $50^{\circ}\text{C}$  and  $27^{\circ}\text{C}$  respectively. Then he placed the mugs of drink in the refrigerator overnight.

Next morning, David took the mugs out of the refrigerator and he immediately measured the temperature of the chocolate drink and milk at the same time.

The temperatures of the chocolate drink and milk are shown in the table.

Drink	Temperature ( $^{\circ}\text{C}$ )
Chocolate drink	(a) _____
Milk	3

- (a) Complete the table with the correct temperature of the <sup>Chocolate drink</sup> milk after it was taken out from the refrigerator. [1]
- (b) Explain your answer in (a). [2]

---



---

David touched the mug of milk which was taken out of the refrigerator as shown in the diagram.

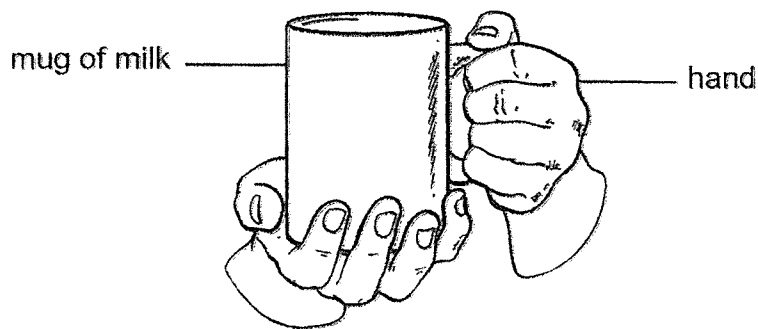

- (c) He commented that his hand felt cold. Explain why his hand felt cold. [1]

---



---

Score	4
-------	---

37. Helen used a magnet to remove a ball that had dropped inside a tank. She placed the bar magnet against the tank, near the ball as shown in the diagram.

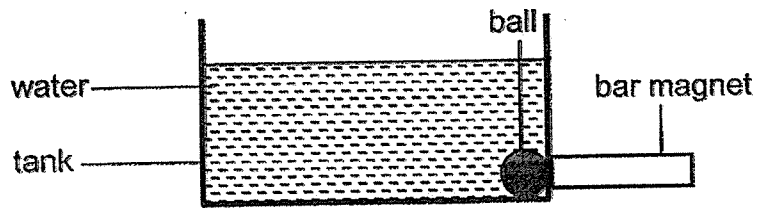

Then, Helen moved the bar magnet and ball upwards as shown below.

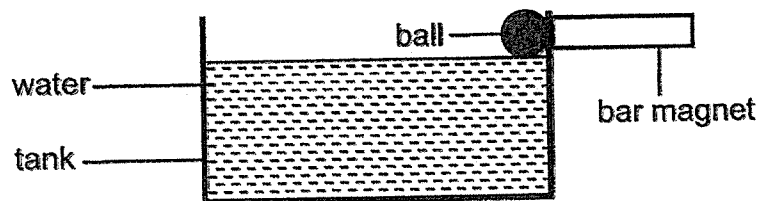

- (a) State the property of the tank that enabled the ball to move up together with the magnet? [1]

---

- (b) Suggest an example of a material that the tank can be made of. [1]

---

- (c) Explain how Helen was able to remove the ball from the tank. [2]

---

---

End of Paper

Score	4
-------	---



YEAR : 2022  
 LEVEL : PRIMARY 4  
 SCHOOL : RAFFLES GIRLS' PRIMARY SCHOOL  
 SUBJECT : SCIENCE  
 TERM : END OF YEAR EXAMINATION

**(BOOKLET A)**

Q1	3	Q2	4	Q3	3	Q4	4	Q5	4
Q6	2	Q7	2	Q8	3	Q9	4	Q10	1
Q11	1	Q12	2	Q13	2	Q14	3	Q15	3
Q16	1	Q17	4	Q18	3	Q19	1	Q20	4
Q21	2	Q22	1	Q23	3	Q24	1	Q25	1

**(BOOKLET B)**

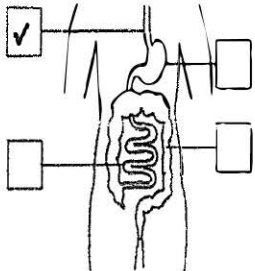
Q26	a)	
	b)	Food from the gullet is next passed on to the <u>stomach</u>
Q27	a)	(i) leaf (ii) stem
	b)	(i) Set-up X. The plant for Set-up X had more roots than the plant for Y. Thus, Set-up X's plant was able to absorb more water through its root for the plant. (ii) Yes. It has leaf to make food and roots to absorb water.
Q28	a)	*is lighter than*
	b)	*is heavier than*
Q29	The ice cube on the glass rod melts <u>slower</u> than the ice cube on the metal rod as glass is a <u>poorer</u> conductor of heat than metal.	
Q30	a)	Plastic is a <u>non-magnetic</u> material.
	b)	Magnet B was <u>repelling</u> magnet A.
Q31	a)	Part B, The mass of Part B decreases as the plant grows. The baby plant uses, absorbs nutrients from Part B at the plant grows.
	b)	3
	c)	The seed in Set-up N. The seed has air, water, warmth. These factors are required for the seed to germinate.

Q32	a)	
	b)	140
	c)	The pieces of food in Set-up G is smaller than Set-up F, so it has a larger surface <sup>area</sup> <del>are</del> in contact with the digestive juices, resulting in a faster rate of digestion.
Q33	a)	Strip C. It could bend the greatest distance. Hence, it is the most flexible to make it into a belt as I can wrap, bend around the waist of a person.
	b)	No. Material E started to break when a mass of 100g was hung on it. Hence it is not strong enough to with stand the weight of the calendar which is heavier than 100g.
Q34	a)	The reading on the electronic balance would increase after some air was pumped into the water dispenser.
	b)	There is more air in the water dispenser which has mass
	c)	Remove some water from the water dispenser. The air will occupy the space previously occupied by the water. As air does not have a definite volume.
Q35	a)	Material R. No light was detected by the light sensor when R was placed on either position 1 or 2. Thus, no light can pass through Material R so it can be used to make a curtain that blocks all light from entering.
	b)	Jeremy conducted the experiment in a dark room to ensure that the light detected by the light sensor is only from the light source, which is the torch, and not from some other light source in the room.
	c)	8
Q36	a)	3
	b)	The chocolate drink lost heat to the cold air in the fridge until it reached the same temperature as the cold air in the fridge.
	c)	His hand lost heat to the cold mug of milk.
Q37	a)	Non-magnetic material
	b)	Plastic
	c)	The magnet's magnetic force passes through the tank which is non-magnetic. The magnet attracted the ball and moved it up.