



CATHOLIC HIGH SCHOOL
END-OF-YEAR EXAMINATION (2021)
PRIMARY FIVE
SCIENCE
BOOKLET A

Name: _____ ()

Class: Primary 5 - _____

Date: 28 October 2021

28 questions

56 marks

Total Time for Booklets A and B: 1 hour 45 minutes

INSTRUCTIONS TO CANDIDATES

Do not turn over this page until you are told to do so.

Follow all instructions carefully.

Answer all questions.

Shade your answers in the Optical Answer Sheet (OAS) provided.

This booklet consists of 21 printed pages, excluding the cover page.

Booklet A (28 × 2 marks)

For each question from 1 to 28, four options are given. One of them is the correct answer. Make your choice (1, 2, 3 or 4). Shade your answer on the Optical Answer Sheet. (56 marks)

- 1 Animal P was found in a garden.



Which characteristics confirm that animal P is an insect?

- A It has wings.
- B It has feelers.
- C It has six legs.
- D It has three body parts.

- (1) A and C only
- (2) C and D only
- (3) A, B and D only
- (4) A, B, C and D

- 2 Noah wants to classify the three animals, X, Y and Z, according to their body covering.



X



Y



Z

Which of the following shows the correct classification of the animals according to their body covering?

	Have scales	Do not have scales
(1)	X	Y and Z
(2)	Z	X and Y
(3)	X and Y	Z
(4)	Y and Z	X

3 Study the table below.

	Parts of the digestive system			
	A	B	C	D
Digestion is completed			✓	
Removal of water from food				✓
Digestion takes place	✓	✓	✓	

Key ✓ : present

Which of the following correctly represents A, B, C and D?

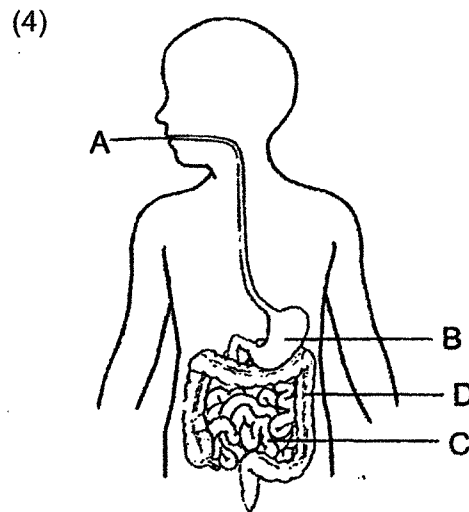
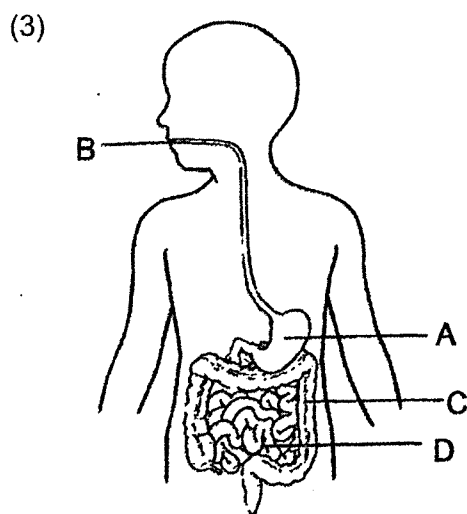
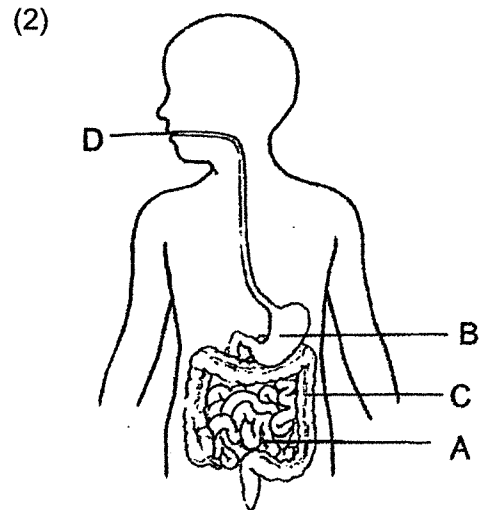
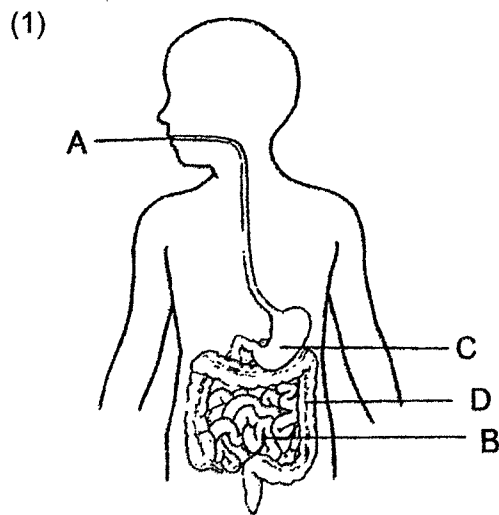

4 Study the diagram below.

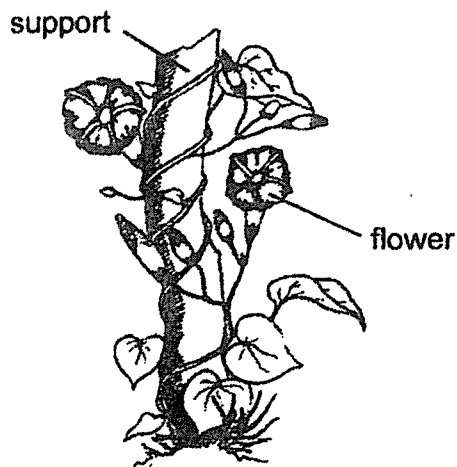

Based on the diagram, which statements are correct?

- A The plant can bear fruits.
- B The plant has a weak stem.
- C The plant reproduces from spores.

- (1) A and B only
- (2) A and C only
- (3) B and C only
- (4) A, B and C

5 The diagram shows how energy is passed on to the living things.

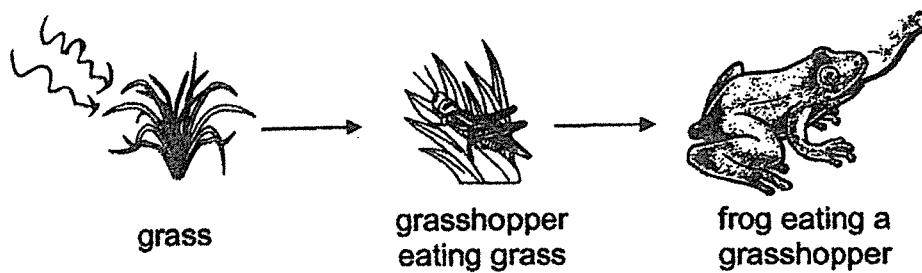

The main source of energy that is passed on from one living thing to another comes from the _____.

- (1) Sun
- (2) nutrients
- (3) chlorophyll
- (4) carbon dioxide

6 Which cycle shows the correct sequence of the reproduction of a flowering plant?

(1)

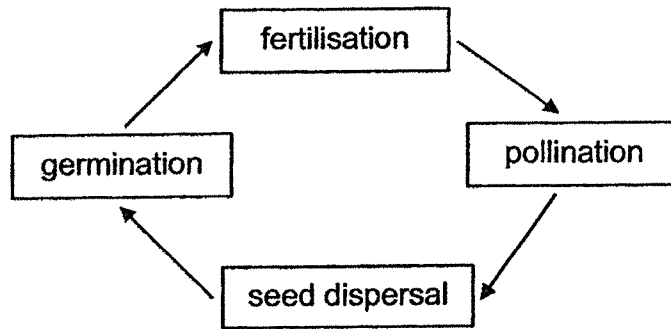

(2)

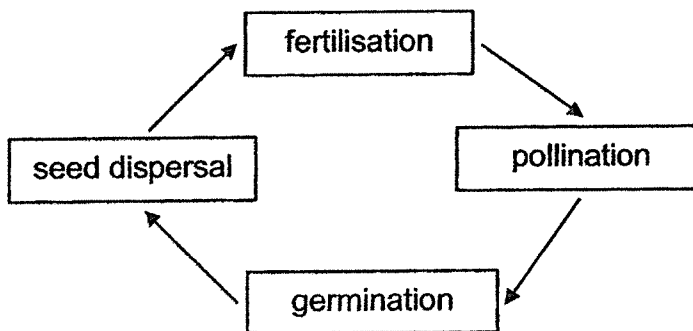

(3)

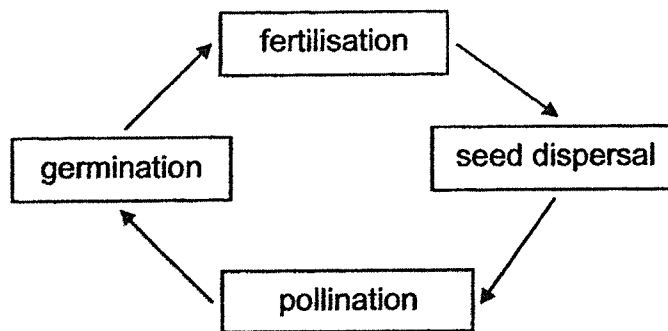

(4)

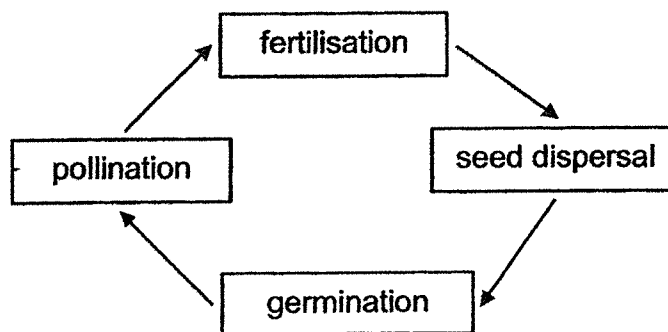

7 The diagram below shows the life cycles of two animals.

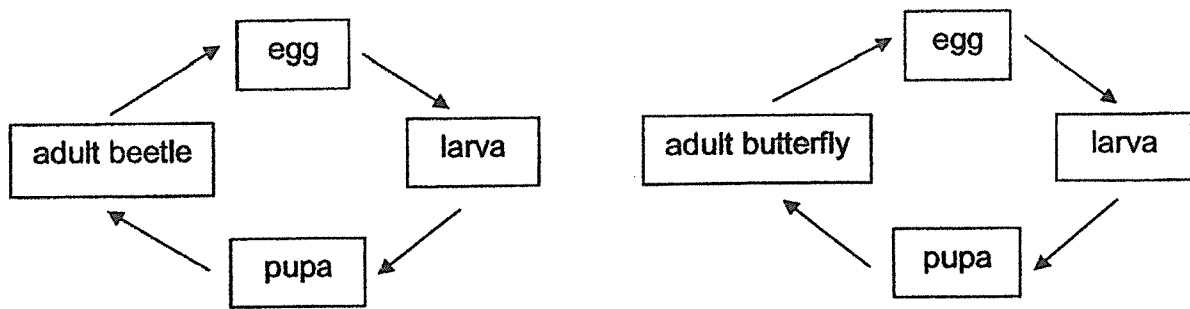

Which statements about the life cycles of the animals are correct?

- A Both give birth to young alive.
- B Both their young do not resemble the adult.
- C The young will only become insects at the adult stage.
- D The pupa does not eat before reaching the adult stage.

- (1) A and C only
- (2) B and D only
- (3) A, C and D only
- (4) B, C and D only

8 A pupil made three statements about sexual reproduction in humans:

- A The fertilised egg is found in the ovary.
- B Fertilisation starts when the egg enters the sperm.
- C The fertilised egg develops into a baby in the womb.

Which statement(s) is/are correct?

- (1) A only
- (2) C only
- (3) A and B only
- (4) B and C only

- 9 The diagram below shows how water and food are transported in a plant.

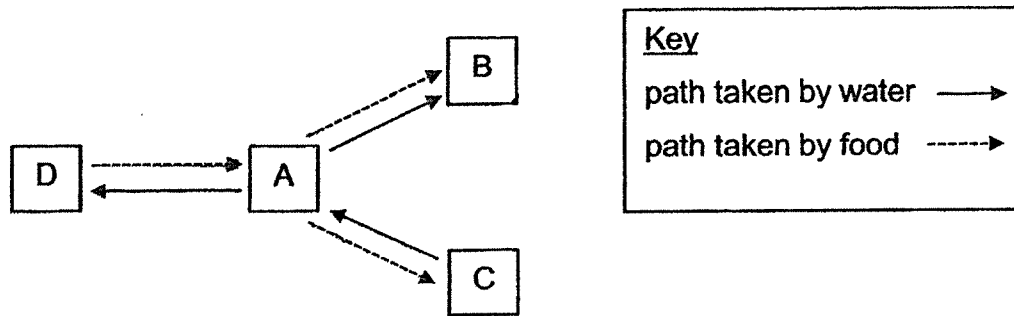

Which of the following correctly represents A, B, C and D?

	A	B	C	D
(1)	flowers	leaves	roots	stem
(2)	roots	stem	flowers	leaves
(3)	stem	flowers	roots	leaves
(4)	stem	flowers	leaves	roots

- 10 The graph below shows the changes in Wei Ming's heart rate. He ran and then stopped after some time.

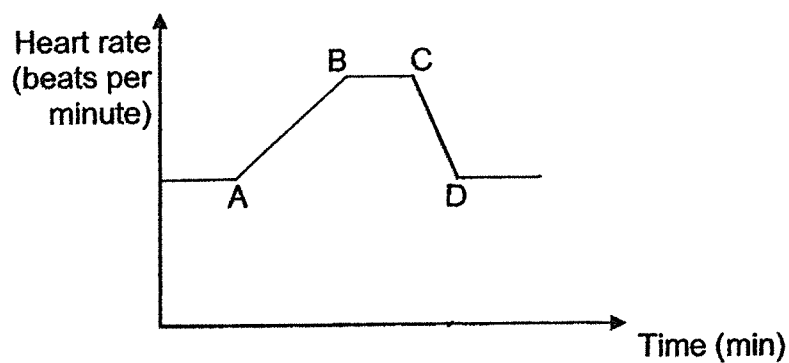

At which point, A, B, C or D, did Wei Ming stop exercising?

- (1) A
 (2) B
 (3) C
 (4) D

11 The diagram below shows fruits P and Q.

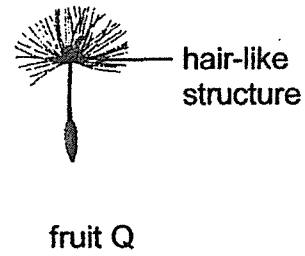
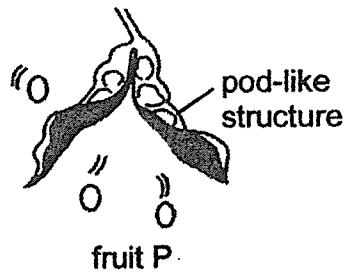

Which graph correctly shows the relationship between the distance the seeds are dispersed from their parent plant and the amount of wind?

(1)

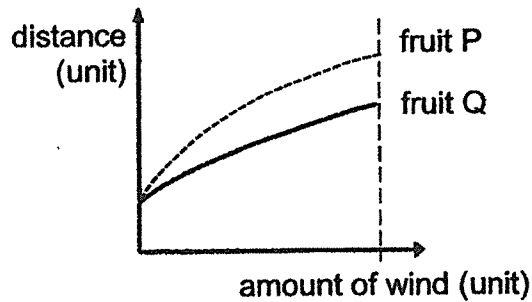

(2)

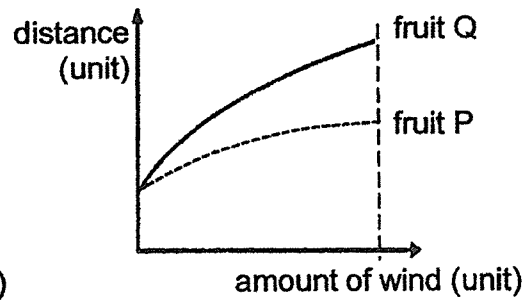

(3)

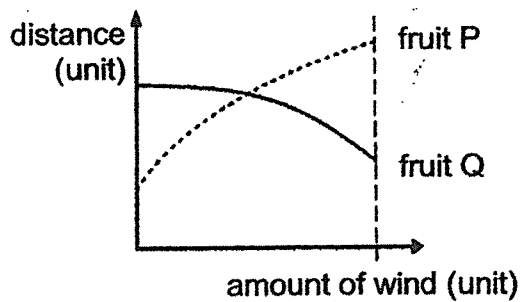

(4)

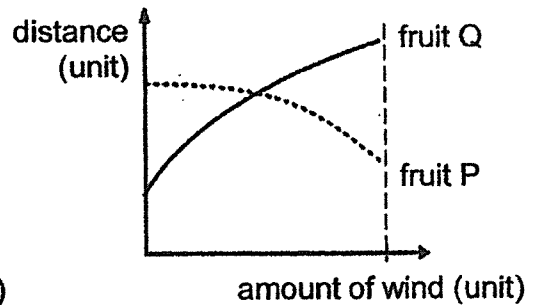

- 12 John prepared four set-ups, A, B, C and D. Using identical plants in each set-up, the conditions in each of the four set-ups are shown below.

Conditions	Set-ups			
	A	B	C	D
water	✓	✓		✓
oxygen		✓	✓	✓
fertiliser			✓	
sunlight	✓	✓	✓	✓
carbon dioxide	✓			✓

<u>Key</u> ✓ : present

Which two set-ups should John use to find out how the presence of carbon dioxide affects the rate of photosynthesis?

- (1) A and B
- (2) A and C
- (3) B and D
- (4) C and D













- 13 Enoch wants to investigate whether leaves can make food if the tiny openings on the leaves are coated with oil. The table below shows how Enoch prepares leaves A, B and C from the same plant placed in the garden. Excess food made in the leaves is stored as substance X.

There are more tiny openings found on the underside of the leaves.

Leaf	Description
A	not coated with oil
B	only the upper side of the leaf is coated with oil
C	only the underside of the leaf is coated with oil

After two days, he conducts a test on the leaves using liquid Y. He puts two drops of liquid Y on each leaf. Liquid Y will turn from brown to blue-black if substance X is present in the leaves.

Which of the following shows the results of the test?

	Leaf A	Leaf B	Leaf C
(1)	 blue black	 blue black	 blue black
(2)			
(3)			
(4)			

- 14 Shu Hui carried out an experiment using three set-ups as shown below. At the start, the colour of liquid L in each set-up was red. The glass tanks were sealed and left in a well-lit room.

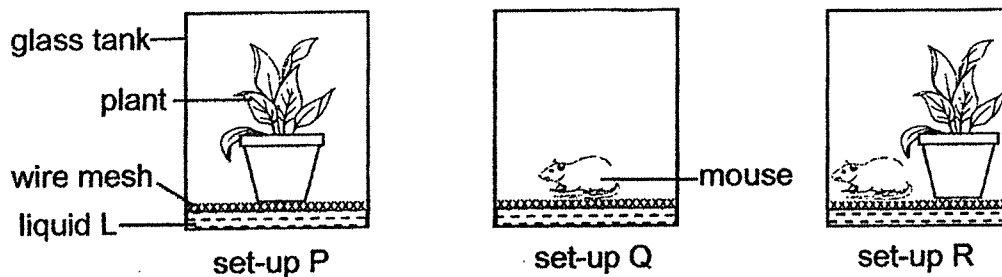

The colour of liquid L would change according to the amount of carbon dioxide present in the tank.

Amount of carbon dioxide	Colour of liquid L
less than normal	purple
normal	red
higher than normal	yellow

What would the colour of liquid L in each set-up be after three hours?

	set-up P	set-up Q	set-up R
(1)	purple	yellow	red
(2)	purple	red	purple
(3)	yellow	yellow	red
(4)	yellow	red	purple

- 15 Jing Ting wants to find out if the time taken for seed K to reach the ground is affected by the wingspan of the seed.

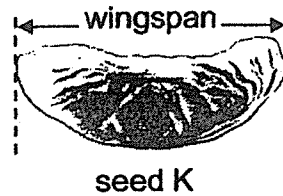

Which variables should she keep constant?

- A mass of seed
- B presence of wind
- C height at which seed is dropped
- D time taken for the seed to reach the ground

- (1) A and D only
- (2) B and C only
- (3) A, B and C only
- (4) A, C and D only

- 16 The diagrams below show the reproductive organs of a male human and a flowering plant.

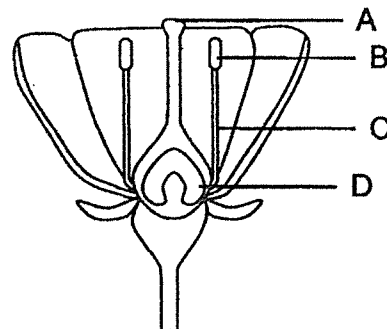
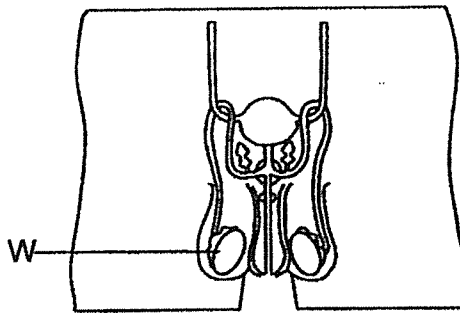

Which part of the flower, A, B, C or D, has the same function as part W in the male reproductive organ?

- (1) A
- (2) B
- (3) C
- (4) D

- 17 Six people were trapped in a lift. There was no fresh air entering the lift. Some adults started banging the door and a child started crying.

Which graph shows the correct change in the amount of gases at different intervals?

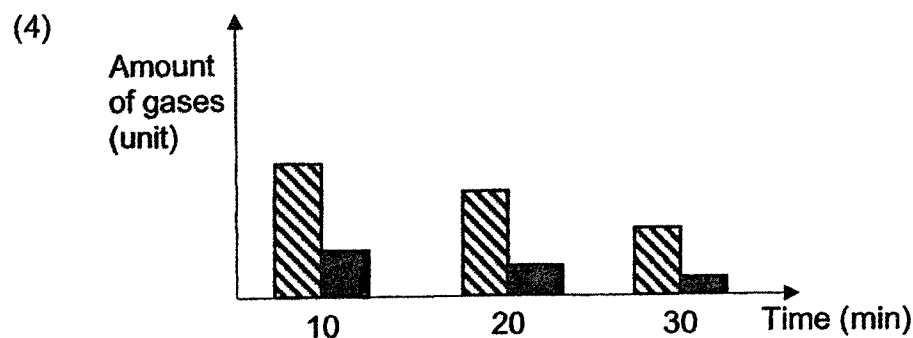
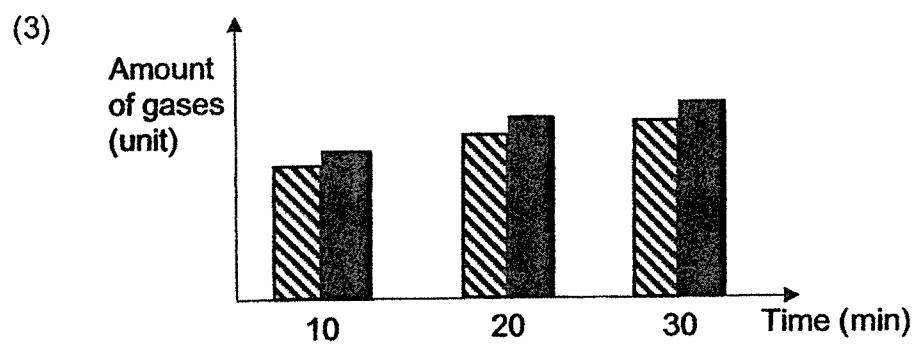
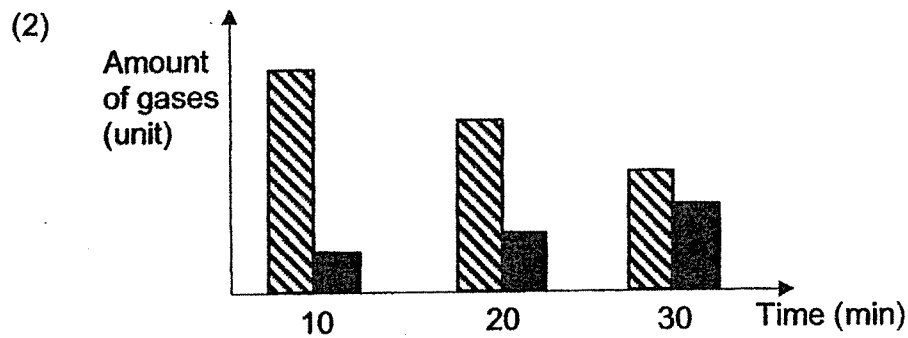
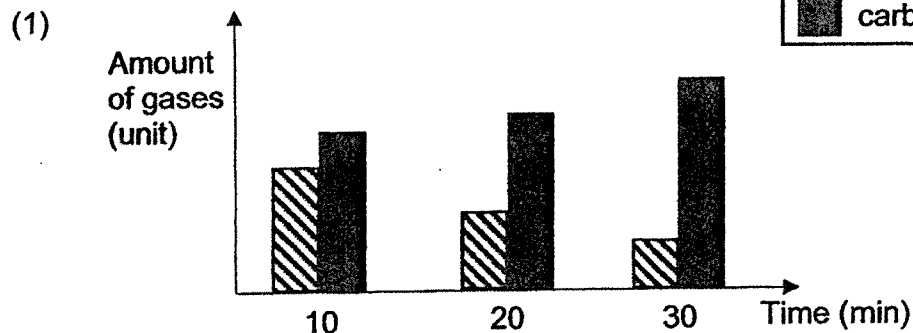
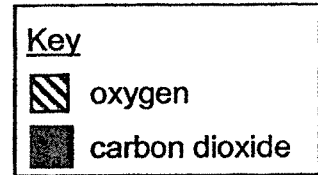

18 Study the diagram below.

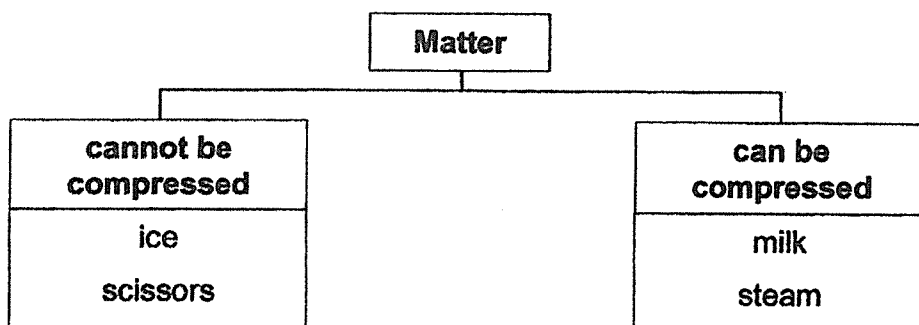

Which matter is not classified correctly?

- (1) ice
- (2) milk
- (3) steam
- (4) scissors

19 The diagram below shows two similar containers of capacity 900 cm³ on a balance. The balance was horizontal.

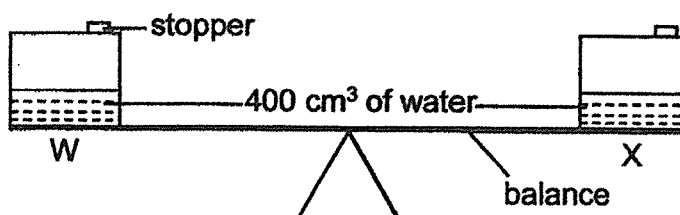

Halim pumped in 100 cm³ of air into container W but did not pump in any air into container X.

Which statement(s) is/are correct after air was pumped into container W?

- A The volume of air in container W was 600cm³.
- B Container W was heavier as more air was added.
- C The balance did not tilt as air can be compressed.

- (1) A only
- (2) B only
- (3) A and C only
- (4) B and C only

- 20 Khai placed bar magnet W at a distance from some iron pins as shown in diagram 1. He then moved magnet W towards the pins until it attracted the pins from a distance, d , in diagram 2. He repeated the procedure and calculated the average distance.

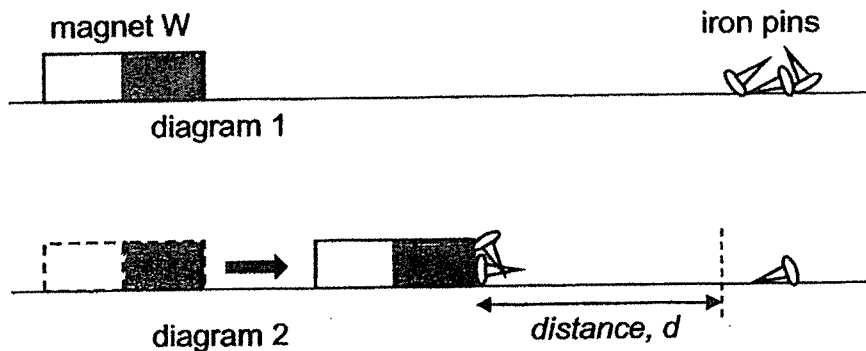

He then repeated the experiment with three other bar magnets, X, Y and Z, of the same length.

	Average distance (cm)
magnet W	2.1
magnet X	1.6
magnet Y	1.9
magnet Z	2.3

Based on the above results, which of the following shows the correct order of the magnetic strength of each magnet, starting from the weakest to the strongest?

	weakest strongest			
	—————→			
(1)	X	Y	W	Z
(2)	X	Y	Z	W
(3)	Z	W	Y	X
(4)	Z	X	Y	W

- 21 Sarah placed some blocks of ice in a sealed glass box. After ten minutes, she noticed that some of the ice melted as shown below.

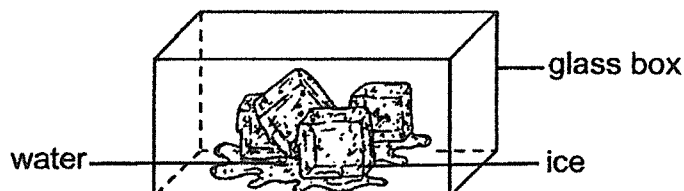

Which of the following describes what happened to the temperature of the ice, water and air in the glass box at the 10th minute?

	Temperature of ice (°C)	Temperature of water (°C)	Temperature of air in the glass box (°C)
(1)	increases	remains the same	decreases
(2)	decreases	decreases	increases
(3)	remains the same	remains the same	decreases
(4)	remains the same	increases	remains the same

- 22 The table below shows the properties of substance G at different temperatures.

Temperature (°C)	Has definite shape?	Has definite volume?
0	yes	yes
100	yes	yes
180	no	yes
260	no	no

Which statement(s) about substance G is/are correct?

- A It is a gas at 260°C.
- B It has a boiling point higher than 180°C.
- C It has a melting point lower than 100°C.

- (1) C only
- (2) A and B only
- (3) B and C only
- (4) A, B and C

23 Claire conducted an experiment using the four set-ups as shown below. She used similar beakers, cups and glass dishes for all the set-ups. They were placed in the Science Room.

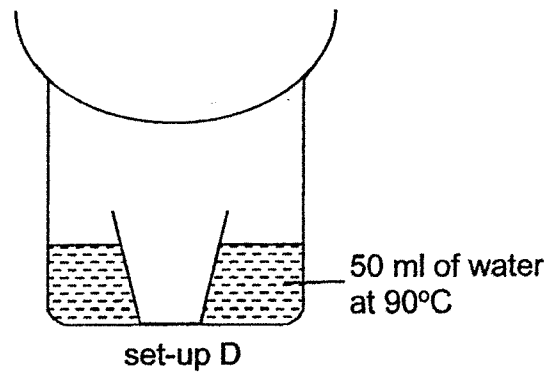
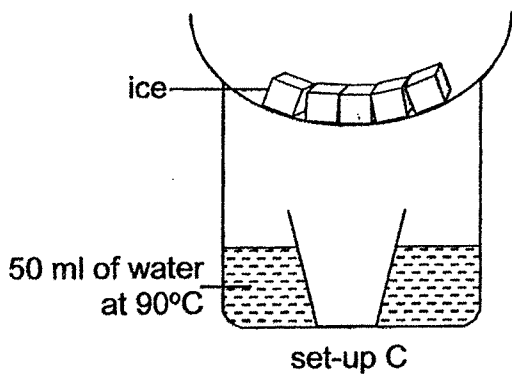
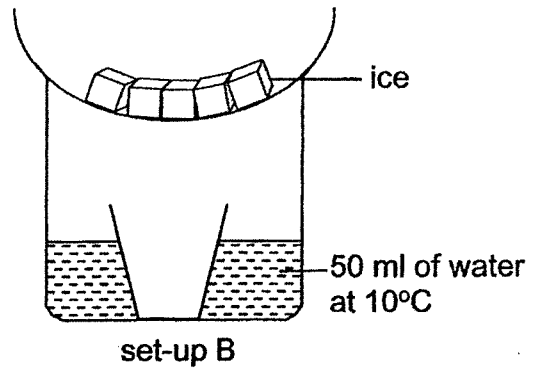
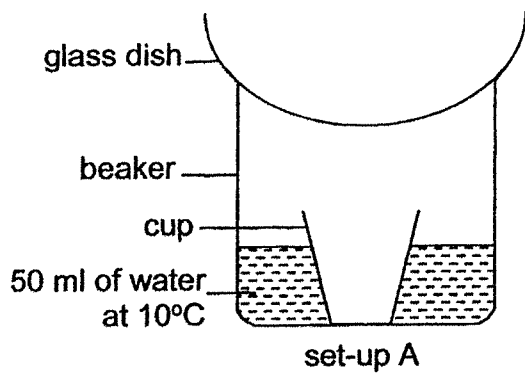

In which set-up would Claire observe the most water collected in the cup after 15 minutes?

- (1) set-up A
- (2) set-up B
- (3) set-up C
- (4) set-up D

24 Matthew set up four different circuits using identical bulbs and batteries as shown below.

In which circuit would bulb A be the brightest?

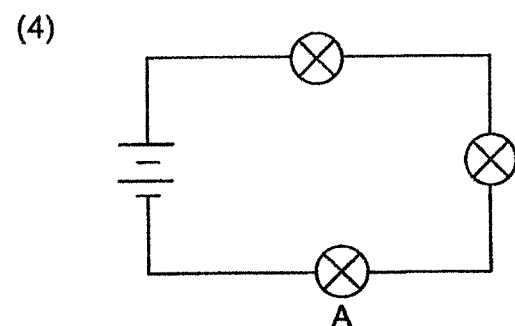
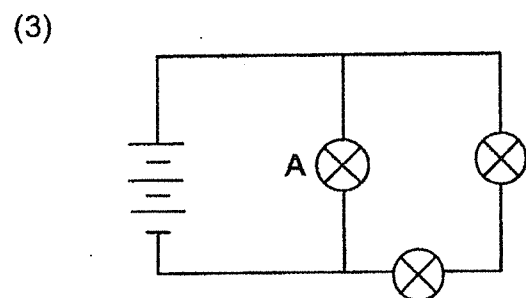
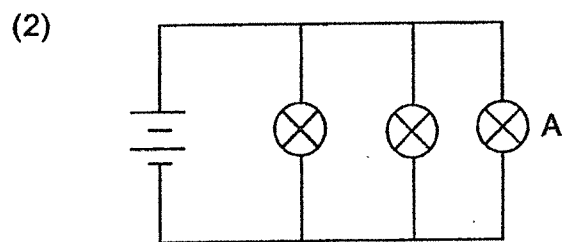
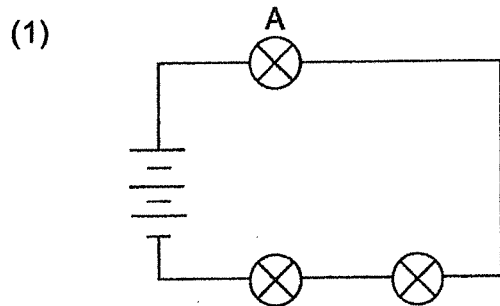

- 25 Dingwei used different materials, W, X, Y and Z, to set up four circuits as shown below. The batteries and bulbs in the circuits were in good working condition.

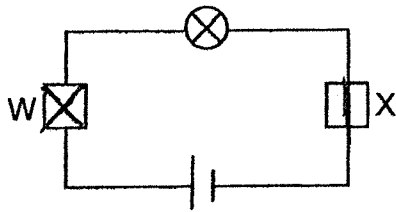

circuit 1

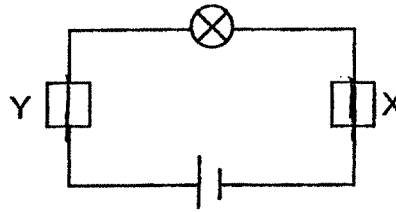

circuit 2

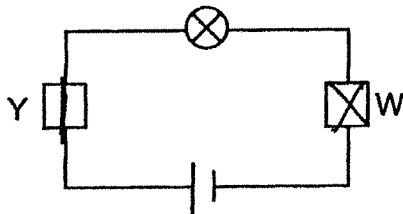

circuit 3

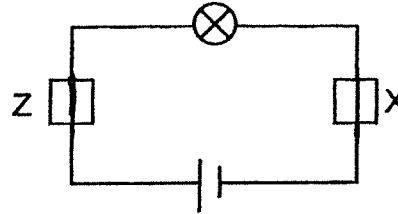

circuit 4

He observed if the bulb in each circuit lit up. He recorded his observations in the table below.

Circuit	Did the bulb light up?	
	Yes	No
1		✓
2	✓	
3		✓
4	✓	

Based on the table above, what could Dingwei conclude?

- (1) Material Y is not an electrical conductor.
- (2) Materials W and Y are electrical conductors.
- (3) Materials X, Y and Z are electrical conductors.
- (4) Materials X and Y are not electrical conductors.

26 Natasha constructed a circuit by connecting two identical batteries, three bulbs and two switches. All the components are in good working condition. She closed only one switch and found that all three bulbs lit up.

Which is not a possible circuit constructed by Natasha?

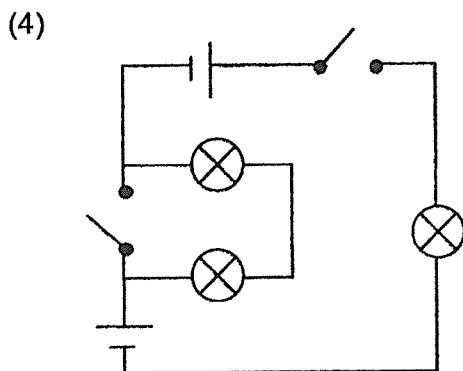
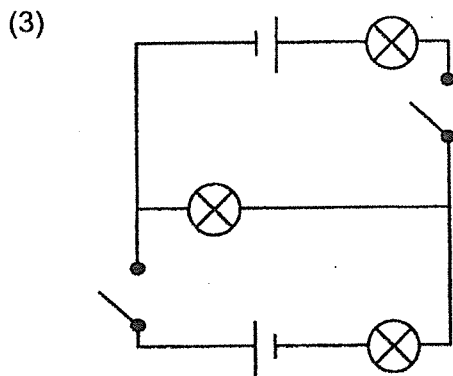
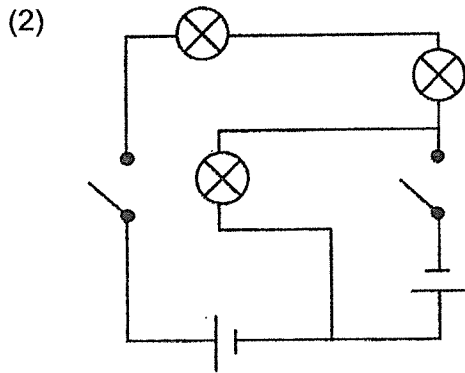
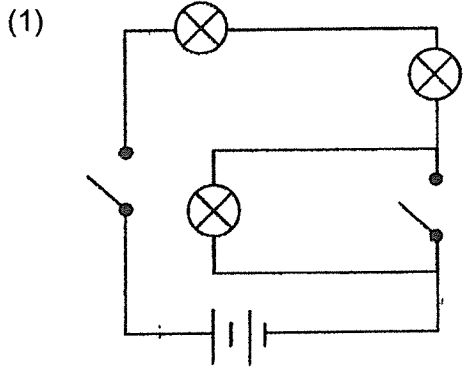

27 Nur set up a tunnel made from a drink carton. She placed a light source at one end of the tunnel and a slanted mirror as shown in the diagram below.

She looked in from the other end of the tunnel but could not see the light.

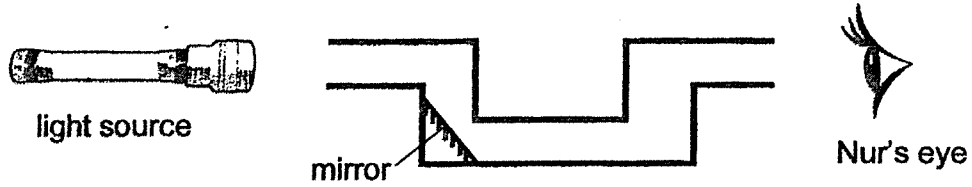

What changes should she make so that she could see the light?

(1)

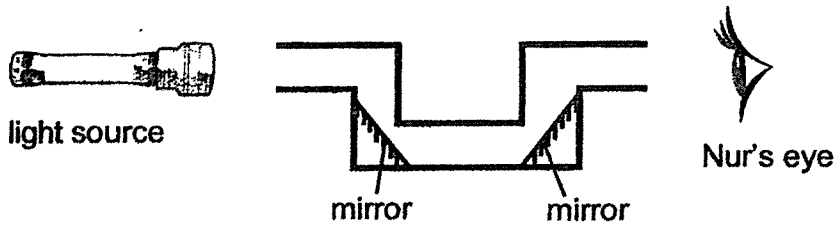

(2)

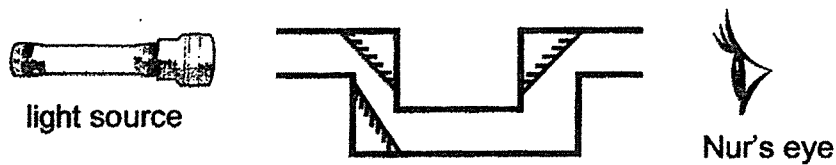

(3)

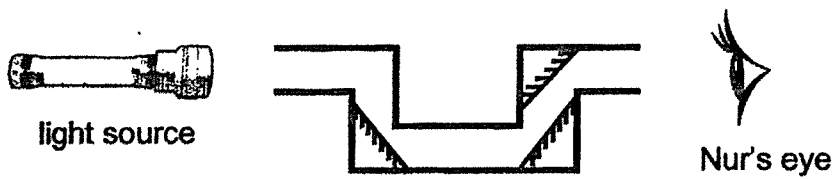

(4)



28 Amy conducted an experiment as shown below.

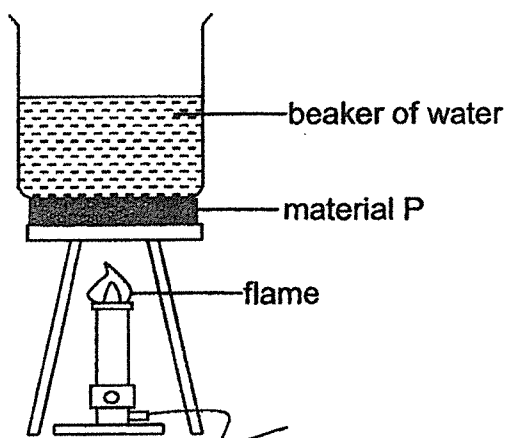

Amy poured different volumes of water into three identical beakers. She placed each beaker on top of materials P, Q and R before heating it.

The table below shows how well each material conducted heat.

	best → poorest		
material	Q	R	P

It was observed that the time taken for the water to boil was the same.

Which of the following most likely show the volume of water Amy poured into the beakers?

	Volume of water (cm ³) in the beaker heated on top of		
	material Q	material R	material P
(1)	300	200	100
(2)	100	300	200
(3)	300	100	200
(4)	100	200	300

End of Booklet A



CATHOLIC HIGH SCHOOL
END-OF-YEAR EXAMINATION (2021)
PRIMARY FIVE
SCIENCE
BOOKLET B

Name: _____ ()

Class: Primary 5 - _____

Date: 28 October 2021

Parent's Signature: _____

Booklet A	56
Booklet B	44
Total	100

13 questions

44 marks

Total Time for Booklets A and B: 1 hour 45 minutes

INSTRUCTIONS TO CANDIDATES

Do not turn over this page until you are told to do so.

Follow all instructions carefully.

Answer all questions.

Write your answers in this booklet.

This booklet consists of 16 printed pages, excluding the cover page.

Booklet B (44 marks)

For questions 29 to 41, write your answers in this booklet.

The number of marks available is shown in brackets [] at the end of each question or part question. (44 marks)

29 The diagram below shows the eggs of a butterfly.

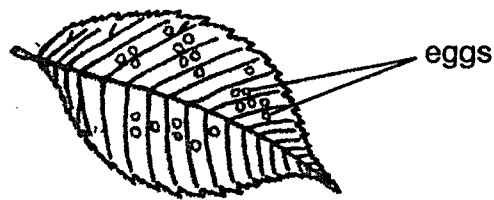

(a) Explain how laying many eggs each time helps the butterfly in their survival. [1]

Butterflies are commonly found near flowering plants.

(b) Describe how butterflies help plants to reproduce. [1]

(Go on to the next page)

SCORE	2
-------	---

30 The diagram below shows a young plant.

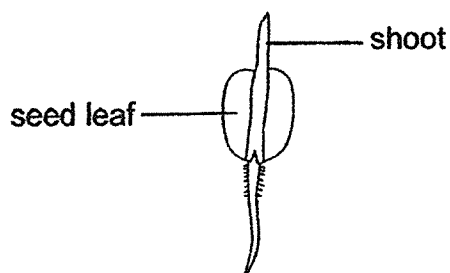

(a) State the conditions needed for the seed to grow into a young plant. [1]

In the graph below, the two curves show changes in the mass of the seed leaf and the shoot of the young plant over a period of time.

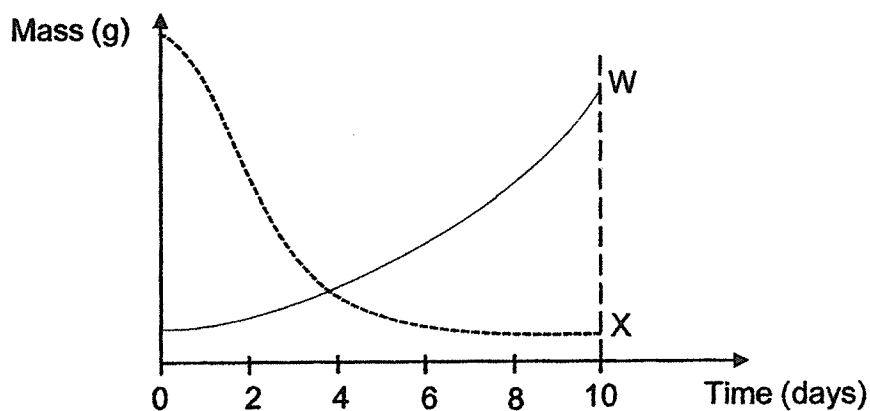

(b) Which curve, W or X, shows how the mass of the seed leaf changes during the ten days? Explain why. [1]

(c) How does the young plant get its food from day 10 onwards? [1]

(Go on to the next page)

SCORE	3
-------	---

- 31 Diagram 1 shows the direction of blood flow in some parts of the human body.

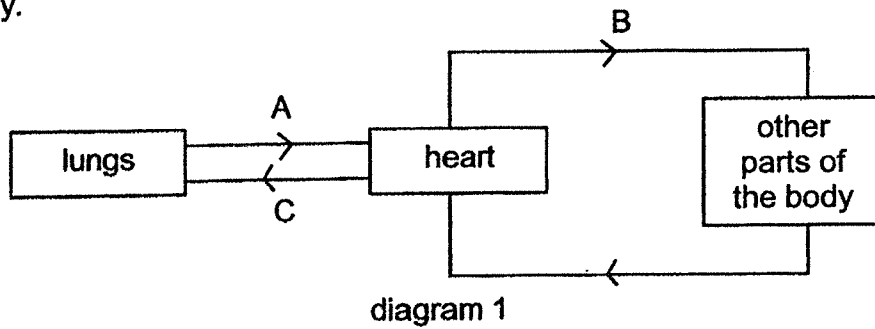

The same amount of blood was taken from A, B and C. The graph below shows the amount of carbon dioxide in the blood samples.

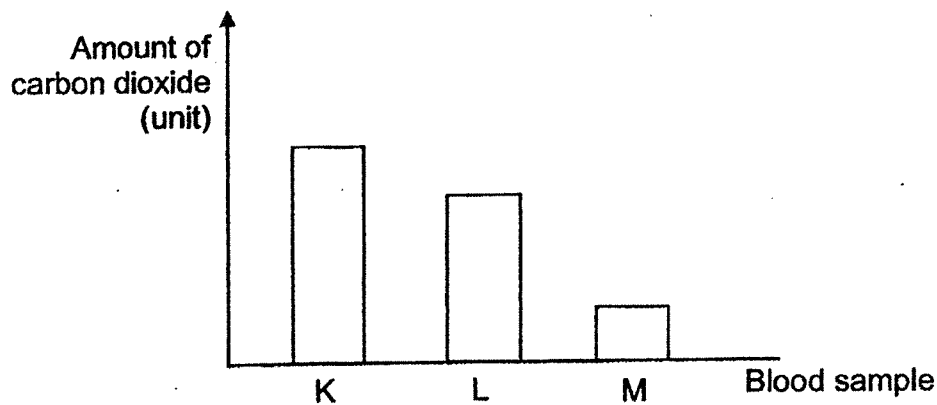

- (a) Which blood, A, B or C, was blood sample K most likely taken from? Give a reason. [1]

- (b) What other substance(s) can be found in the blood samples other than carbon dioxide? Put a (✓) tick in the correct box. [1]

Substance	Present (✓)
water	
nitrogen	
waste materials	

(Go on to the next page)

SCORE	2
-------	---

Continue from Question 31

Diagram 2 below shows the direction of blood flow in some parts of the fish.

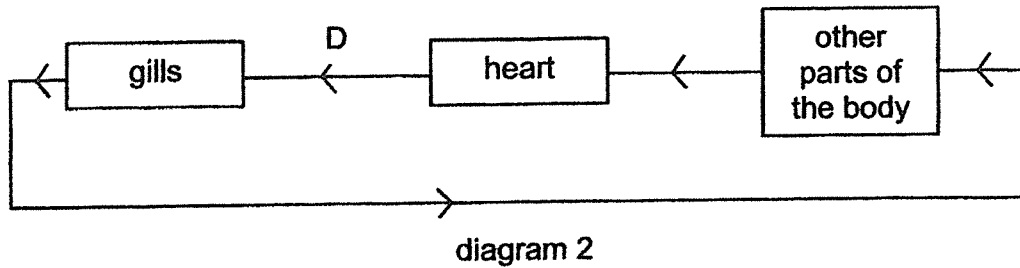

- (c) State a difference between the direction of blood flow in a fish and in a human. [1]

- (d) State a difference between the gas found in the blood flowing in B of diagram 1 and D of diagram 2. [1]

(Go on to the next page)

SCORE	2
-------	---

32 Luke set up an experiment as shown below.

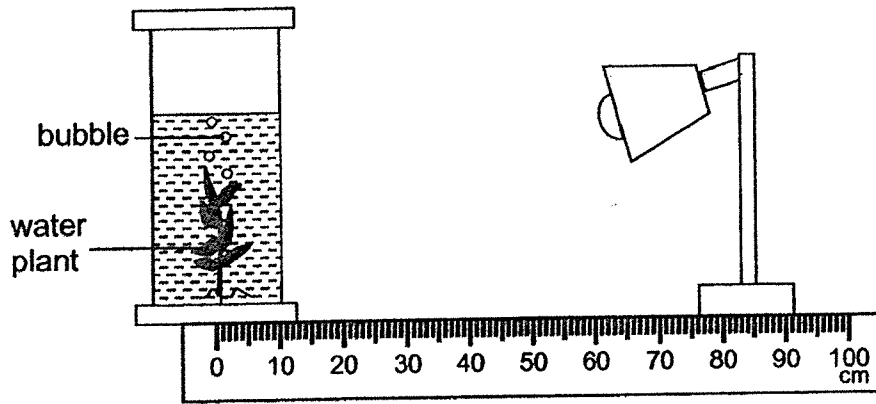

He placed a lamp at a given distance and recorded the number of bubbles produced in one minute by the water plant. He then repeated the experiment at various distances from the lamp as shown in the table below.

Distance between the lamp and the water plant (cm)	10	20	30	40
Number of bubbles produced in one minute	22	16	9	5

(a) State the gas in the bubbles produced. [1]

(b) Based on Luke's results, what is the relationship between the rate of photosynthesis and the distance between the lamp and the water plant? [1]

(c) Luke conducted the experiment in a dark room. Give a reason why this would make the experiment a fair test. [1]

(Go on to the next page)

SCORE	3
-------	---

Continue from Question 32

Luke collected samples of water from two ponds, S and T, and tested the amount of light passing through the water samples. The table below shows the results.

	Amount of light (units)
Sample of water from pond S	325
Sample of water from pond T	150

(d) In which pond, S or T, would the water plant grow better? Explain why. [2]

(Go on to the next page)

SCORE	2
-------	---

33. Mary put a plant into a beaker of blue-coloured water as shown below.

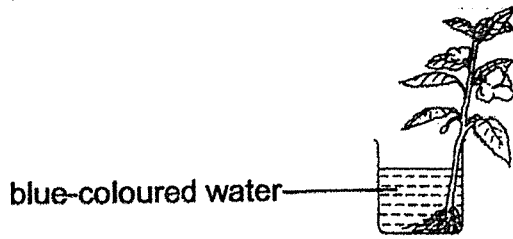

(a) After five hours, Mary observed that the flowers had turned from white to blue. Explain why. [1]

Mary then cut a section of the stem and observed that there were blue dots as shown in the diagram below.

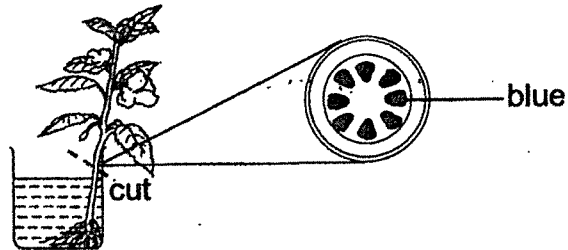

(b) What do the blue dots represent? [1]

Mary removed the outer ring of the stem.

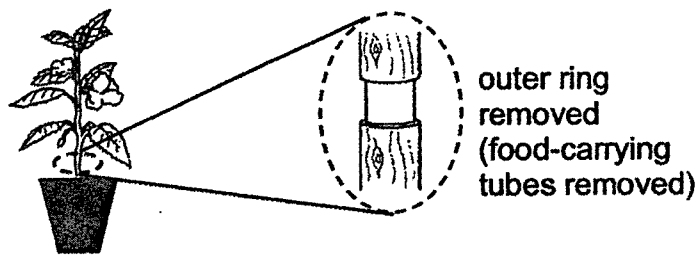

(c) After some time, the plant died. Give a reason why removing the outer ring of the stem caused the plant to die even though Mary watered her plant daily. [1]

(Go on to the next page)

SCORE	3
-------	---

34 Raju used the set-up below to test a certain property of a material.

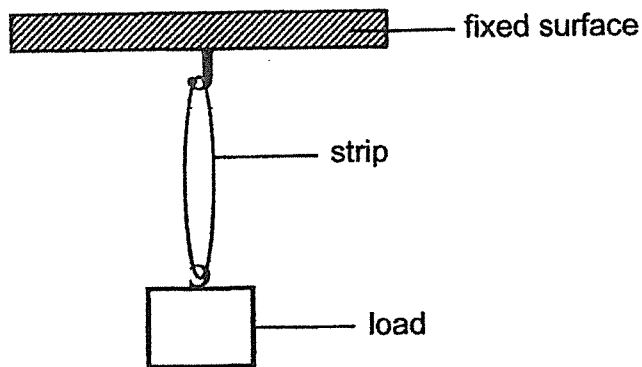

In his experiment, he used strips made of different materials, P, Q and R. He increased the number of loads hung until each strip broke. His results are shown below.

Material	Number of loads hung by the strip before it broke
P	5
Q	8
R	3

(a) State the property of material that Raju studied. [1]

(b) Based on his results, which material, P, Q or R, is most suitable to make a bag that can carry heavy groceries? Give a reason. [1]

(c) State one variable of the strips that Raju has to keep constant when conducting this experiment. [1]

(Go on to the next page)

SCORE	3
-------	---

35 Seng Huat filled a cylinder with water and inverted it into a beaker of water as shown below. He then started blowing air into the cylinder through a straw. The set-up was placed on an electronic balance.

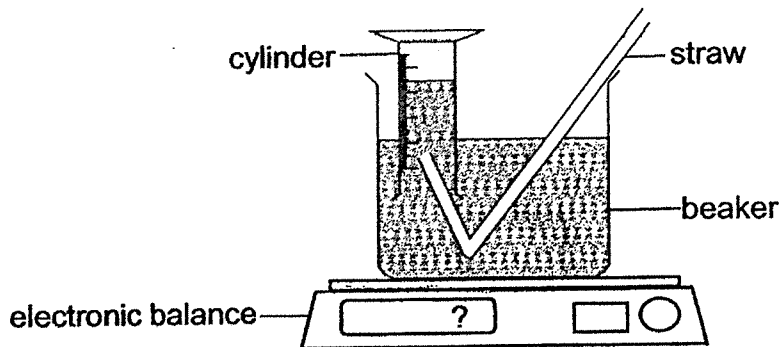

(a) What would happen to the water level in the cylinder when air was blown in through the straw? Explain your answer. [2]

(b) Would the mass of the set-up increase, decrease or remain the same after Seng Huat blew more air into the cylinder? Give a reason. [1]

(c) Seng Huat then removed the cylinder and straw. He inverted the cylinder vertically into the same beaker of water. In the diagrams below, which set-up correctly shows the water level in the cylinder after being inverted? Put a tick (✓) in the box. [1]

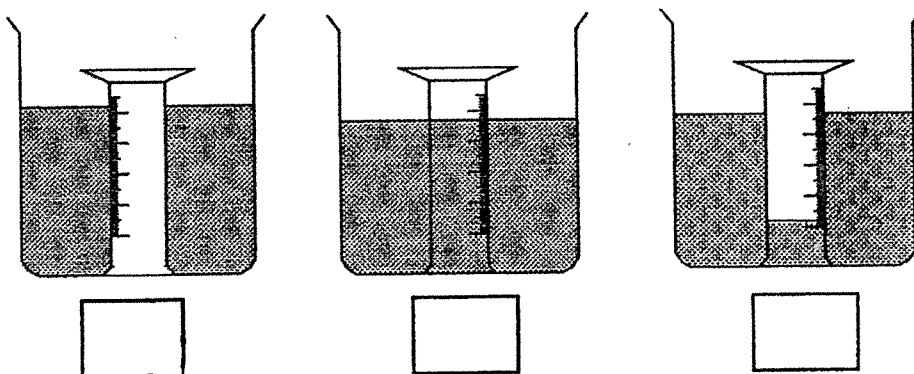

(Go on to the next page)

SCORE	4
-------	---

- 36 The diagram below shows how a light sensor is used to count the number of people entering a mall as they walked in through the door.

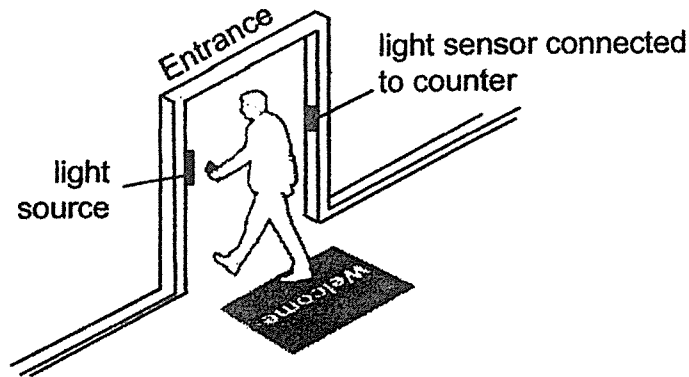

When a person is between the light source and the sensor, the light is blocked. The data recorded by the counter is represented in the graph below.



- (a) Based on the graph, how many people entered the mall in the first minute? [1]

- (b) The light source and the sensor are placed 1 m above the ground.

State whether a child who is shorter than 1 m in height can be counted. Give a reason. [1]

- (c) The set-up is not an accurate tool to count if many people walk through the door at the same time. Explain why. [1]

(Go on to the next page)

SCORE	3
-------	---

- 37 Lenice conducted an experiment as shown below. She first recorded the temperature of air in the bottle. Then she placed several hot stones in the same bottle and closed it so that it was air-tight.

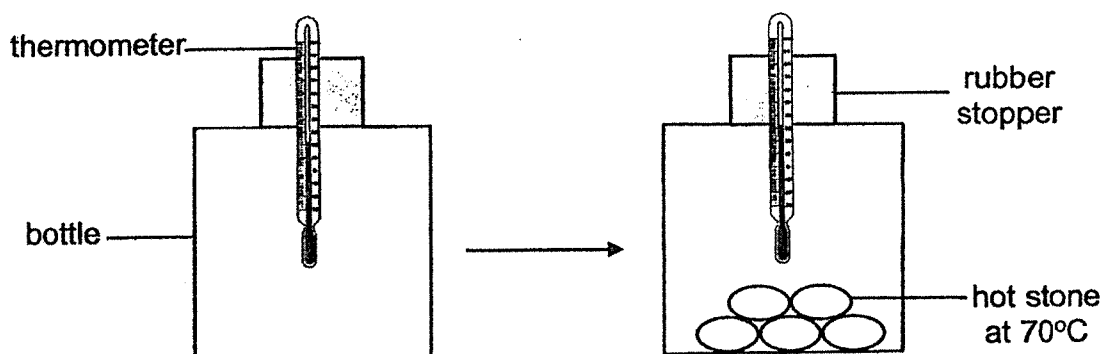

After 15 minutes, she recorded the temperature of air in the bottle as shown below.

Temperature of air in the bottle (°C)	
At the start	15 minutes after placing the stones
40	48

- (a) Give a reason for the increase in the temperature of air in the bottle after the stones were placed. [1]

(Go on to the next page)

SCORE	1
-------	---

Continue from Question 37

Lenice then conducted another experiment as shown below. She used two similar bottles, P and Q, made of different materials. She recorded the temperature of air in both bottles before placing similar hot stones in them.

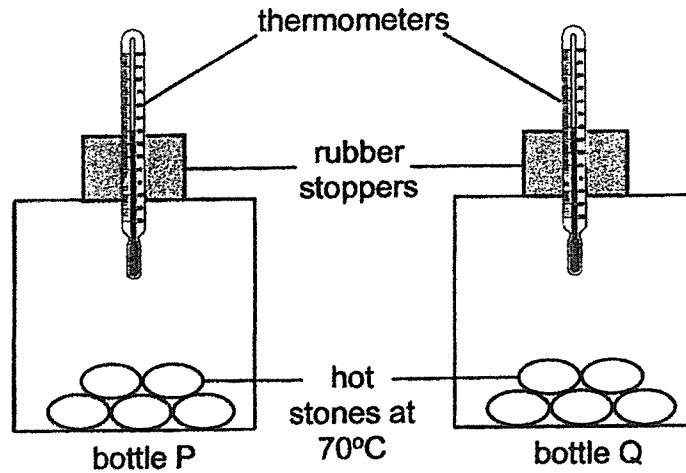

After 15 minutes, she recorded the temperature of air in the bottle as shown below.

	Temperature of air in the bottle (°C)	
	At the start	15 minutes after placing the stones
bottle P	40	48
bottle Q	40	45

(b) Explain why the temperature of air in bottle Q was lower than that in bottle P. [1]

(c) Lenice left the bottles uncovered for 15 minutes before repeating the experiment. Give a reason. [1]

(Go on to the next page)

SCORE	2
-------	---

- 38 Ephraim designed a toy as shown below. The toy shark and magnet J of different masses were hung on the balance. When he placed magnet K under magnet J, the beam balanced. Magnet K was fixed on the table.

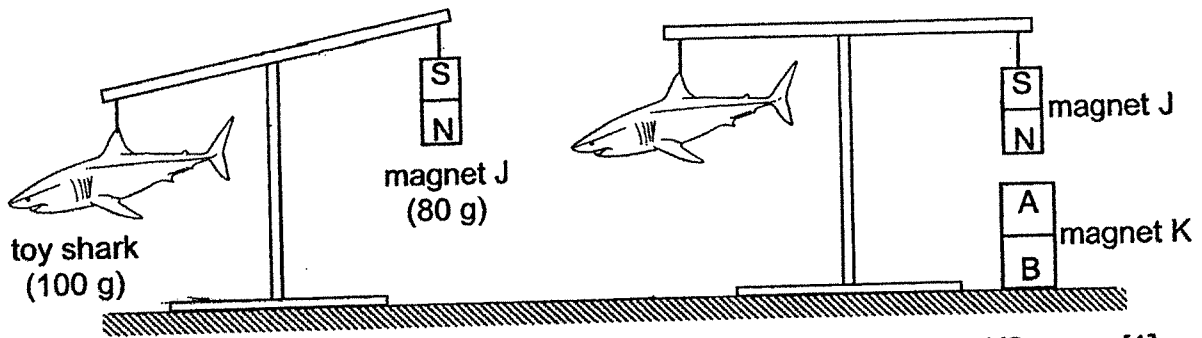

- (a) Based on the diagrams above, what are the poles on magnet K? [1]

Pole A: _____

Pole B: _____

- (b) Explain how the toy shark was balanced by magnets J and K. [2]

Ephraim replaced the toy shark with another lighter toy with a mass of 60 g. He then did something to magnet J so that the beam was balanced.

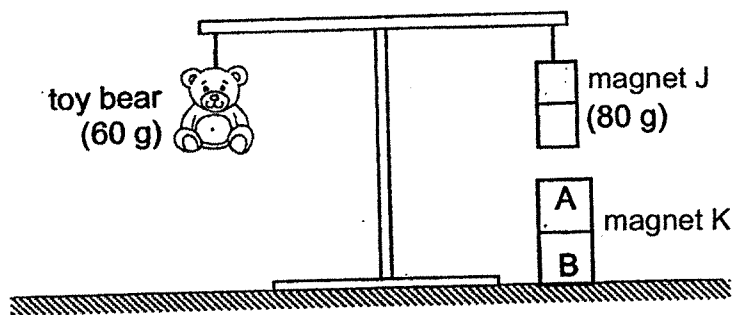

- (c) Suggest what Ephraim could have done to magnet J to keep the beam balanced. [1]

(Go on to the next page)

SCORE	4
-------	---

39 (a) State what freezing means.

[1]

Muthu used a hand sanitiser to spray on his palms on a hot day. When sprayed, the sanitiser came out as tiny droplets of liquid.

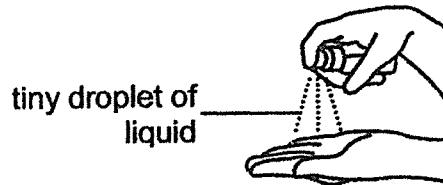

(b) After spraying the hand sanitiser, Muthu's palms felt cooler. Explain why.

[1]

Back home, Muthu opened the refrigerator door and mist was seen as shown.

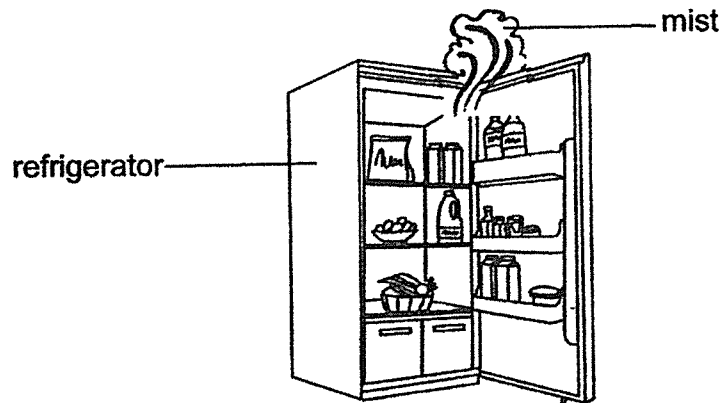

(c) Explain how the mist was formed when the door was opened.

[2]

(Go on to the next page)

SCORE	4
-------	---

40 Six pins, Q, R, S, T, U and V, were fixed onto a wooden board as shown in diagram 1. Diagram 2 shows a circuit tester.

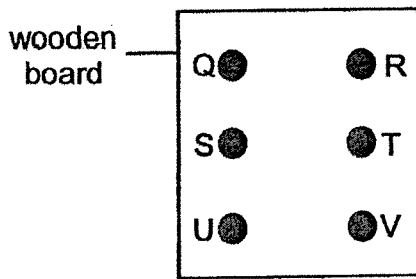

diagram 1

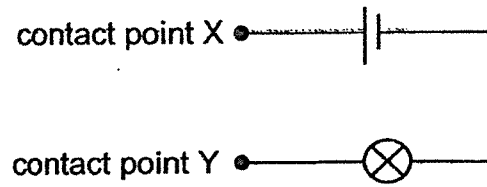
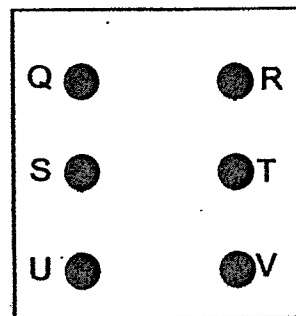
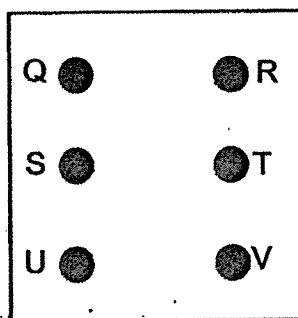

diagram 2

The bulb lit up when contact points X and Y were connected to the various pins. This is shown in the table below.

Pins connected to circuit tester	Did the bulb light up?
S and T	Yes
T and U	Yes
U and V	No
V and S	No
Q and R	No
R and S	Yes

Using three wires for each wooden board below, draw two possible arrangements of how the wires were connected. [2]



(Go on to the next page)

SCORE	2
-------	---

- 41 Peter designed a bell system as shown.
The bell would ring when he pushed open the door.

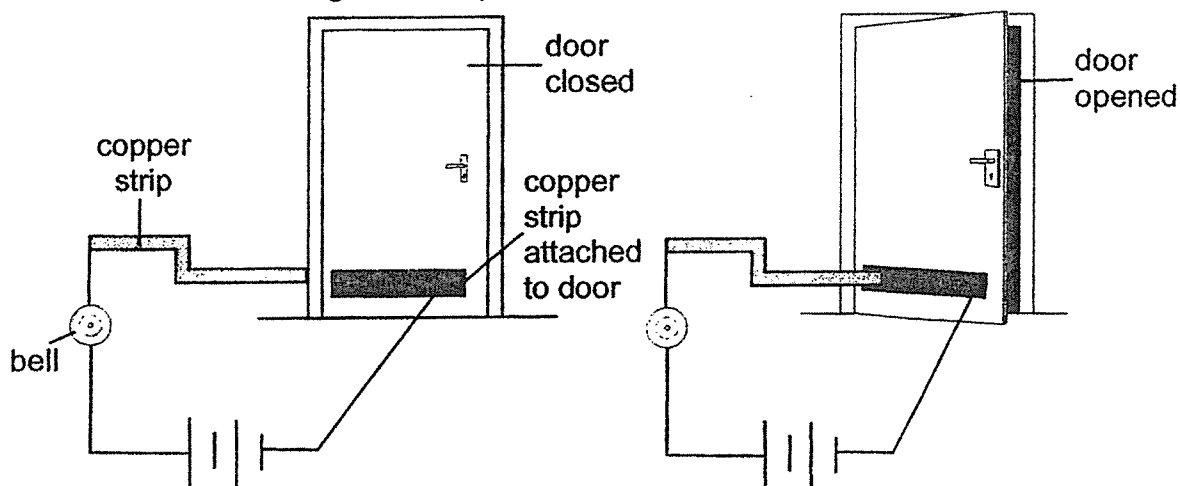

- (a) State a property of the copper strip that makes it suitable to be used in this system. [1]

- (b) Explain how the bell would ring when Peter pushed the door open. [2]

- (c) Peter wanted to improve on his set-up so that a person who could not hear would also be alerted when the door was opened. He added a bulb.
Using symbols, draw in the circuit diagram how the improved set-up will look like. The bell and bulb are connected such that when one does not work, the other will still work. [1]

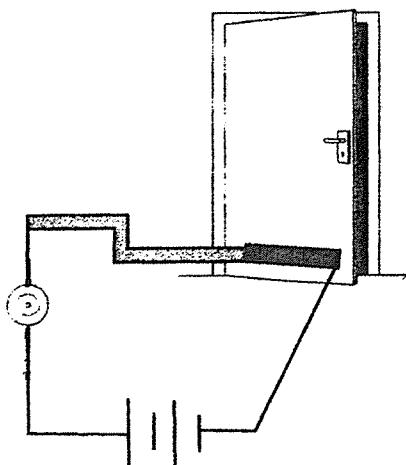

SCORE	4
-------	---

End of Booklet B

ANSWER KEY

YEAR : 2021
LEVEL : PRIMARY 5
SCHOOL : CATHOLIC HIGH SCHOOL
SUBJECT : SCIENCE
TERM : END OF YEAR EXAMINATION

BOOKLET A

Q1	2	Q2	4	Q3	4	Q4	1	Q5	1
Q6	4	Q7	2	Q8	2	Q9	3	Q10	3
Q11	2	Q12	3	Q13	4	Q14	1	Q15	2
Q16	2	Q17	2	Q18	2	Q19	2	Q20	1
Q21	3	Q22	2	Q23	3	Q24	3	Q25	3
Q26	3	Q27	4	Q28	1				

BOOKLET B

Q29	a)	Some eggs may die, thus laying many eggs ensure that some eggs may hatch and grow into adults
	b)	Butterflies
Q30	a)	Warmth, water and oxygen
	b)	W, leaves will start to grow causing it to increase its mass.
	c)	It gets its food from the sunlight, which take in carbon dioxide to make food.
Q31	a)	C, as the other body parts of the body used up the oxygen will its going to the heart to pump new bloods for the lungs to collect more oxygen the repeat the process.
	b)	Water✓ Waste materials✓
	c)	The blood in a human goes from the heart to the lungs, back to the to the heart before going to the other parts of the gills to the other parts of the body.
	d)	The blood in B of diagram one has more oxygen and less carbon dioxide and higher in carbon dioxide.
Q32	a)	Oxygen
	b)	The shorter the distance between the lamp and the water plant, the higher the rate of photosynthesis.
	c)	If Luke did not do it in a dark room, there will be an external source of light that would disrupt the test.
	d)	Pond S, as it has more light units that the plant needs to photosynthesis, while if it was in Pond T, if would not photosynthesis as much as if the plant was in Pond S.
Q33	a)	The roots of the plant absorbed the blue-coloured water and

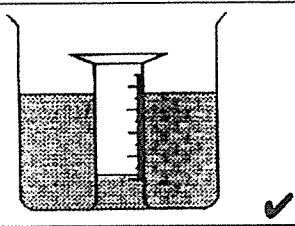
		transferred it to the stem which then transferred the blue-coloured water to the white flowers.		
	b)	water carrying tube		
	c)	The roots of the plant could not get food from the leaves and died so it stopped getting water for the plant.		
Q34	a)	Strength of the material		
	b)	Q, as it was able to hold the most amount of loads before breaking so it would be able to hold the weight of the heavy groceries.		
	c)	The length of each strip.		
Q35	a)	The water level in the cylinder would go lower, as air takes up space, so when air entered the cylinder, it pushed up out the water so that it can fit in the cylinder.		
	b)	Mass of the set-up would increase as air has weight and the level of the water will also increase as the air takes up space in the cylinder.		
	c)			
Q36	a)	two		
	b)	A child who is shorter than one meter in height cannot be counted as the light sensor cannot be blocked by the child.		
	c)	When the light source is blocked, one person is recorded to walk through the door, however if many people go pass at once, light source would record one person walking pass only as light source is block once thus not accurate		
Q37	a)	The air gain heat from the stones causing the air to increase its temperature.		
	b)	Bottle Q's material is a better conductor of heat than Bottle P, causing it to lose heat to the surroundings faster.		
	c)	She wanted to see if not touching the bottle affects the temperature.		
Q38	a)	<table border="1" data-bbox="414 1691 670 1780"> <tr> <td>Pole A: South</td> </tr> <tr> <td>Pole B: North</td> </tr> </table>	Pole A: South	Pole B: North
	Pole A: South			
	Pole B: North			
b)	Magnet J was attracted to magnet K, causing magnet J to push down the balance making the toy shark move upwards and the beam to be balanced			
c)	Ephraim could turn the magnet J over so that magnet J and K would be repelling against each other causing magnet J to move upwards to make it balanced.			

Q39	a)	Liquid turning solid
	b)	Hand sanitizer has a low boiling and melting point. Since, Muthu's hand is
	c)	Sanitiser contains alcohol. It feels cold when we spray sanitiser on our palm because the alcohol in it evaporates quickly, drawing away heat as it does so. It is cold as it evaporates.
Q40		
Q41	a)	It is a electrical conductor
	b)	When the door is closed, it is an opened circuit, but when the door is opened, the copper strip on the door will touch copper strip making it to be a closed circuit and causing the bell to ring.
	c)	