



**RAFFLES GIRLS' PRIMARY SCHOOL
END-OF-YEAR EXAMINATION 2021
MATHEMATICS (PAPER 1)
PRIMARY 5**

Name: _____ ()

Form Class: P5 _____

Math Teacher: _____

Date: 28 October 2021

Duration: 1 hour

Your Paper 1 Score (Out of 45 marks)	
Your Paper 2 Score (Out of 55 marks)	
Your Total Score (Out of 100 marks)	
Parent's Signature	

INSTRUCTIONS TO CANDIDATES

1. Do not turn over this page until you are told to do so.
2. Follow all instructions carefully.
3. Answer **ALL** questions and show all working clearly.
4. **NO** calculator is allowed for this paper.

Questions 1 to 10 carry 1 mark each. Questions 11 to 15 carry 2 marks each.
For each question, four options are given. One of them is the correct answer.
Make your choice (1, 2, 3 or 4). Shade your answer (1, 2, 3 or 4) on the OAS provided.
All diagrams are not drawn to scale. (20 marks)

1. Express 40 ℓ 30 ml in litres.

(1) 40.003 ℓ

(2) 40.03 ℓ

(3) 40.3 ℓ

(4) 4.03 ℓ

2. Which digit in 7531.640 is in the thousandths place?

(1) 0

(2) 5

(3) 7

(4) 4

3. Express $\frac{7}{8}$ as a decimal.

(1) 0.078

(2) 0.780

(3) 0.875

(4) 1.142

4. A machine takes 60 minutes to print 4800 sheets of paper. How many sheets of paper does it print in 40 minutes?

(1) 120

(2) 240

(3) 3200

(4) 7200

5. Mrs. Chun had 8 kg of rice. She used $\frac{5}{6}$ of it to make sushi. How much rice had she left?

(1) $\frac{1}{6}$ kg

(2) $1\frac{1}{3}$ kg

(3) $6\frac{2}{3}$ kg

(4) $7\frac{1}{6}$ kg

6. Find $\angle y$ in the figure shown.

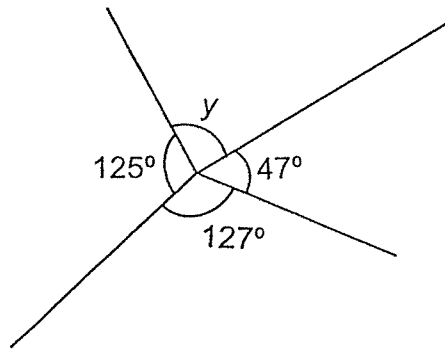

(1) 55°

(2) 61°

(3) 78°

(4) 127°

7. The table shows the number of pupils who volunteered for a donation drive over 5 days.

Day	Monday	Tuesday	Wednesday	Thursday	Friday
Number of pupils who volunteered	14	0	?	6	4

The average number of pupils who volunteered for the donation drive from Monday to Friday was 8. How many pupils volunteered on Wednesday?

- (1) 40
(2) 32
(3) 16
(4) 8
8. A solid cuboid has a square base with a height of 3 cm. The area of the shaded face is 18 cm^2 . What is its volume?

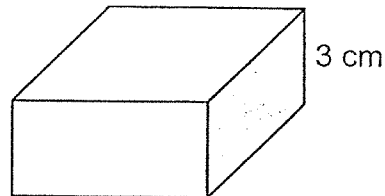

- (1) 54 cm^3
(2) 108 cm^3
(3) 162 cm^3
(4) 972 cm^3

9. Express 40 g as a percentage of 2 kg.

- (1) 5%
- (2) 2%
- (3) 20%
- (4) 50%

10. Siti baked 98 cupcakes at first. She gave 56 cupcakes to her friends. Find the ratio of the number of cupcakes she gave to her friends to the number of cupcakes left.

- (1) 3 : 4
- (2) 4 : 3
- (3) 4 : 7
- (4) 7 : 4

11. What is the missing number?

$$5.24 \times 30 = \underline{\hspace{2cm}} \div 10$$

- (1) 1.572
- (2) 15.72
- (3) 157.2
- (4) 1572

12. In the figure, ABC is a triangle. Find the area of triangle ABC.

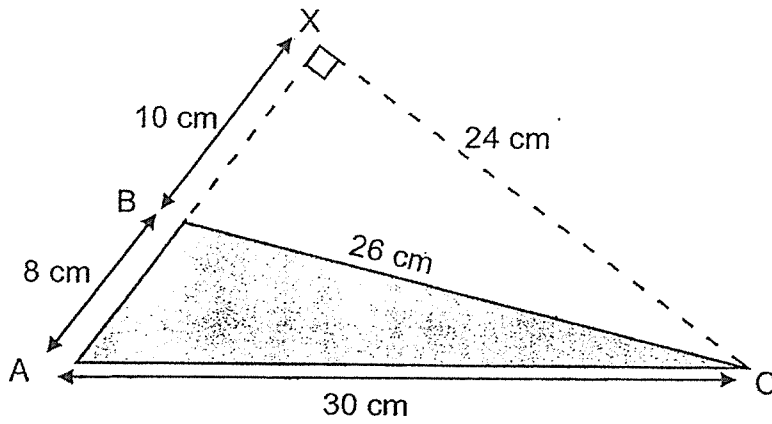

- (1) 96 cm²
- (2) 104 cm²
- (3) 120 cm²
- (4) 216 cm²

13. In the figure, MNP is an isosceles triangle. NPL is a right-angled triangle. LN is a straight line. MN = MP. Find the value of $\angle NLP$.

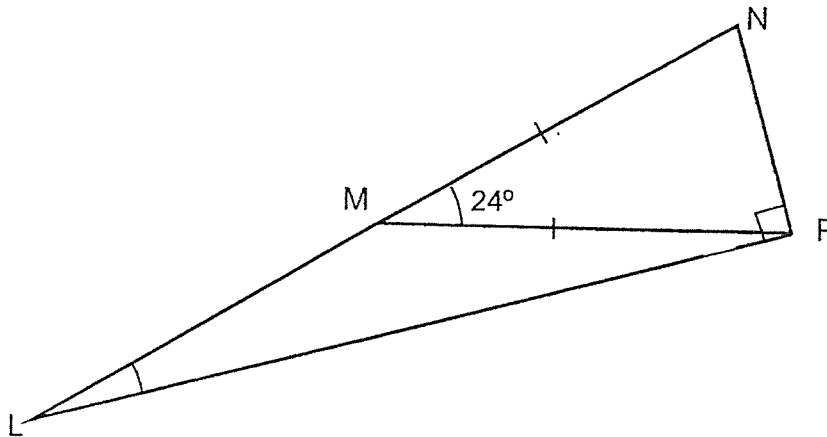

- (1) 12°
- (2) 24°
- (3) 78°
- (4) 156°

14. A rectangular piece of paper is 2 m long and $\frac{7}{8}$ m wide. What is the area of the piece of paper?

(1) $\frac{7}{16} \text{ m}^2$

(2) $1\frac{3}{4} \text{ m}^2$

(3) $2\frac{7}{8} \text{ m}^2$

(4) $5\frac{3}{4} \text{ m}^2$

15. Linda earns \$20 when she sells one book. For every 4 books she sells, she earns an extra \$20. How many books must she sell to earn \$600?

(1) 6

(2) 7

(3) 24

(4) 28

Questions 16 to 20 carry 1 mark each. Write your answers in the spaces provided.
For questions that require units, give your answers in the units stated. All diagrams are
not drawn to scale. (5 marks)

16. Find the value of $(12 + 36) \div 8 \times 6$.

Ans: _____

17. A ball of string with a length of 26 m was cut into 4 equal pieces. What was the length of each piece? Leave your answer as a mixed number in the simplest form.

Ans: _____ m

18. Express 8906 cm in metres.

Ans: _____ m

19. Ailee had $\frac{5}{6}$ of milk. She used $\frac{3}{4}$ of it to make a milkshake. How many litres of milk was left? Leave your answer in the simplest form.

Ans: _____ ℓ

20. In the figure, AB and CD are straight lines. Find the value of $\angle AOE$.

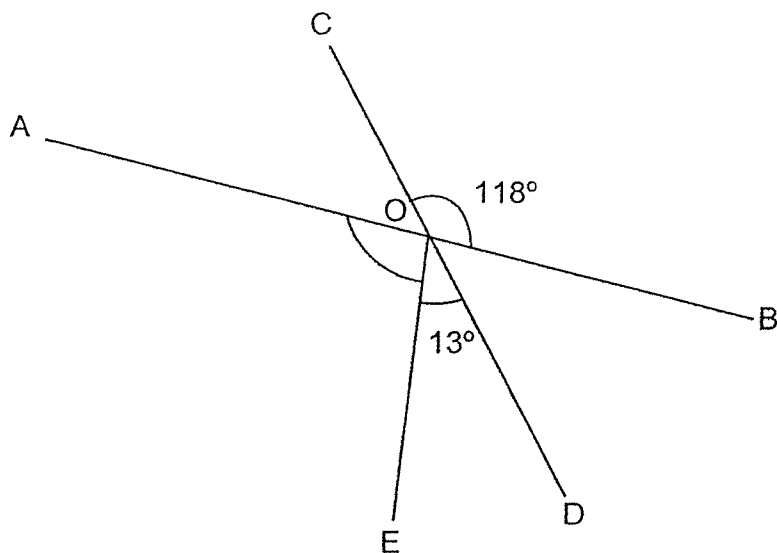

Ans: _____ °

Questions 21 to 30 carry 2 marks each. Show your working clearly in the space provided for each question and write your answers in the spaces provided. For questions that require units, give your answers in the units stated. All diagrams are not drawn to scale. (20 marks)

21. Find the value of

(a) $5.7 \div 100$

(b) 0.23×3000

Ans: (a) _____

Ans: (b) _____

22. What are the missing numbers in the blanks?

(a) $7 : 12 = \underline{\quad} : 36$

(b) $\underline{\quad} : 42 = 12 : 28$

Ans: (a) _____

Ans: (b) _____

23. A box of erasers were distributed equally to 54 pupils. 9 of them gave all their erasers away to the remaining pupils. These remaining pupils received 2 more erasers each. How many erasers were distributed to each pupil at first?

Ans: _____

24. In the figure, ABCD and PRSD are two identical rectangles. Find the shaded area of the figure.

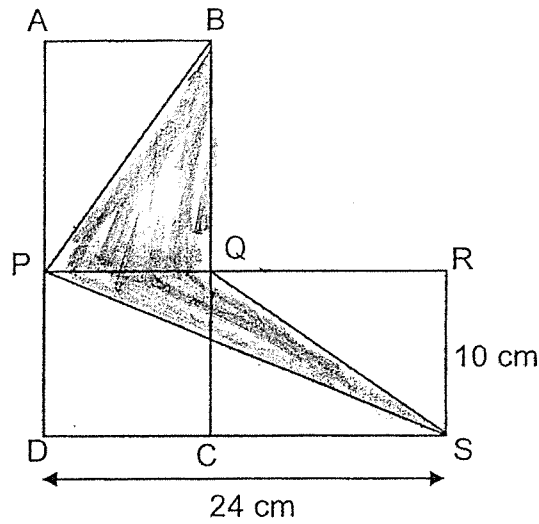

Ans: _____ cm^2

25. Jennie had \$36. She spent $\frac{5}{9}$ of her money on a book and $\frac{1}{12}$ of it on a sandwich. How much money did she have left?

Ans: \$ _____

26. When a container is $\frac{1}{6}$ filled with sugar, it has a mass of 250 g. When the container is $\frac{1}{3}$ filled with sugar, it has a mass of 340 g. What is the mass of the empty container?

Ans: _____ g

27. 160 pupils signed up for a day camp. 25 of them did not turn up for the camp. 60% of the pupils who were present were boys. How many girls were there at the camp?

Ans: _____

28. The ratio of Raj's age to Lisa's age now is 9 : 5. Lisa is 24 years younger than Raj. How many years ago was Raj four times as old as Lisa?

Ans: _____

29. The volume of an empty tank is 96ℓ . When a tap is turned on, it takes 20 minutes to fill the tank completely. What is the volume of water in the tank after the tap is turned on for 7 minutes?

Ans: _____ ℓ

30. The figure shows a rectangular piece of paper folded at its two corners.

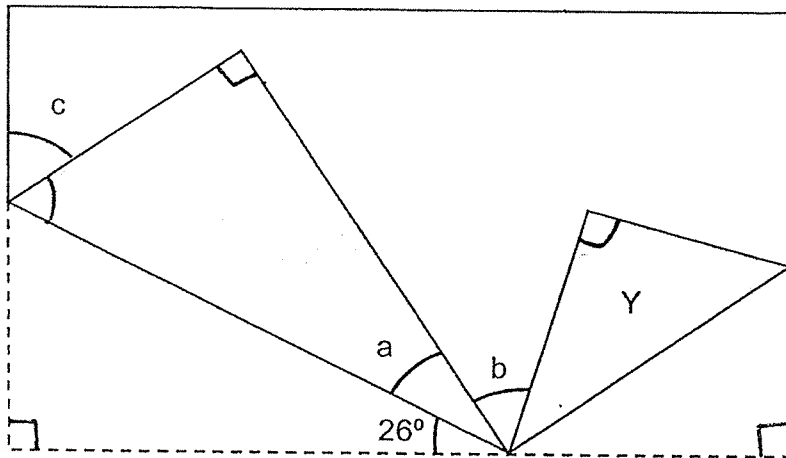

Each of the statements below is either true, false or not possible to tell from the information given. For each statement, put a (\checkmark) to indicate your answer.

	Statements	True	False	Impossible to tell
(a)	$\angle a$ is equal to $\angle b$.			
(b)	$\angle c$ is equal to 64° .			
(c)	The smaller triangle, Y, is an equilateral triangle.			

End of Paper
 ☺ Please check your work carefully ☺

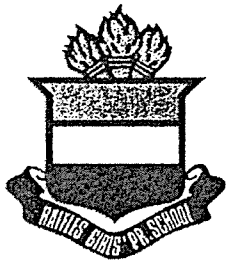

RAFFLES GIRLS' PRIMARY SCHOOL
END-OF-YEAR EXAMINATION 2021
MATHEMATICS (PAPER 2)
PRIMARY 5

Name: _____ ()

Form Class: P5 _____

Math Teacher: _____

Date: 28 October 2021.

Duration: 1 h 30 min

INSTRUCTIONS TO CANDIDATES

1. Do not turn over this page until you are told to do so.
2. Follow all instructions carefully.
3. Answer **ALL** questions and show all working clearly.
4. The use of calculator is allowed for this paper.

Questions 1 to 5 carry 2 marks each. Show your working clearly in the space provided for each question and write your answers in the spaces provided. For questions which require units, give your answers in the units stated. All diagrams are not drawn to scale. (10 marks)

1. The table shows the charges for bicycle rental.

Bicycle Rental Charges	
For the first hour	\$8
For every additional $\frac{1}{2}$ hour or part thereof	\$1.10 on all days

Sean rented a bicycle from 8.30 a.m. to 11.45 a.m. How much did he pay for the rental of the bicycle?

Ans : \$ _____

2. Mrs Bong bought a vacuum cleaner. The cost of the vacuum cleaner before GST was \$880. How much did she pay for the vacuum cleaner including the 7% GST?

Ans : \$ _____

3. On Monday, Ronnie started saving some money in his piggy bank. Every day he saved \$0.60 more than the previous day. He saved \$4.60 on Friday. How much did Ronnie save on Monday?

Ans : \$ _____

4. At a food donation centre, Mr Gomez shared 20 kg of rice equally among 9 people in a day. How many kilograms of rice did each person receive in a week? Leave your answer as a mixed number in the simplest form.

Ans : _____ kg

5. ABC is an equilateral triangle and BCD is an isosceles triangles. $DB = DC$. Find $\angle BDC$.

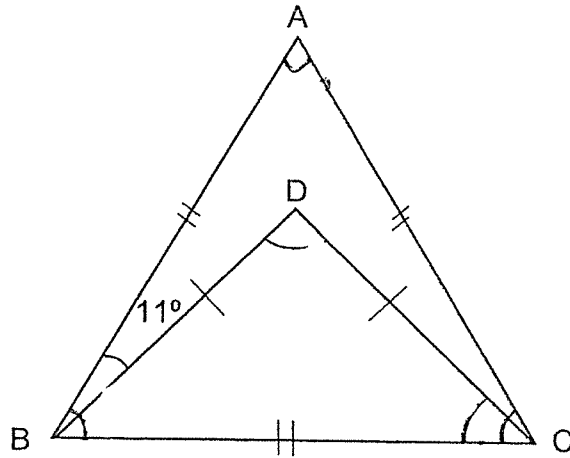

Ans : _____^o

For questions 6 to 17, show your working clearly in the space provided for each question and write your answers in the spaces provided.
The number of marks available is shown in brackets [] at the end of each question or part-question. All diagrams are not drawn to scale. (45 marks)

6. On a Sunday at the Science Centre, there were three times as many children as adults. An adult ticket cost \$10 and a child ticket cost \$6. A total amount of \$11 060 was collected from the sale of the tickets on that day.

(a) What was the total cost of one adult and three children tickets?

(b) How many people were at the Science Centre on Sunday?

Ans : (a) _____ [1]

(b) _____ [2]

7. The ratio of the length of one side of Square A to the length of one side of Square B is 2 : 5. The perimeter of Square B is 60 cm.

(a) What is the area of Square B?

(b) Find the ratio of the area of Square A to the area of Square B. Express the ratio in its simplest form.

Ans : (a) _____ [1]

(b) _____ [2]

8. Aliah bought a roll of ribbon and cut it into 3 pieces of different length.
The length of the first piece was $\frac{3}{10}$ of the length of the ribbon at first.
The length of the second piece was $\frac{2}{7}$ of the remaining length of the ribbon.
The length of the third piece was 445 cm long. What was the length of the first piece of cut ribbon?

Ans : _____ [3]

9. Cubical Tank P has a length of 36 cm and is $\frac{7}{9}$ filled with water. Some of the water is poured into an empty rectangular fish tank measuring 50 cm long, 18 cm wide and 26 cm high until it is completely full.

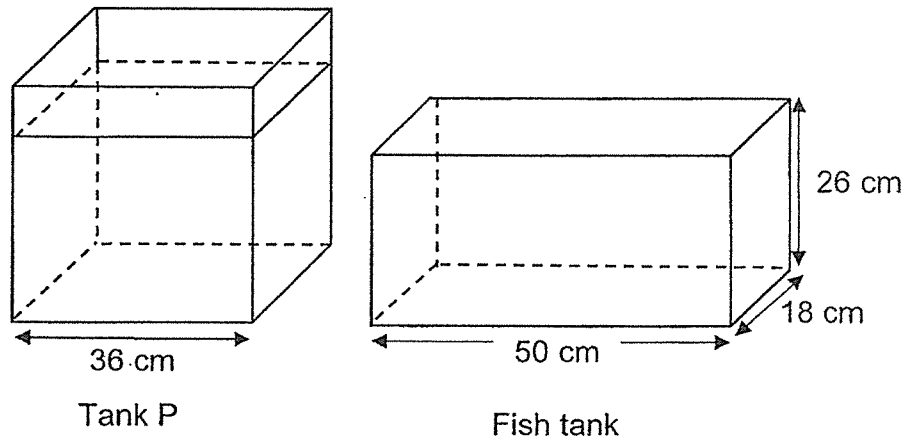

- (a) What is the volume of water in Tank P at first? Give your answer in cm^3 .
- (b) What is the volume of water left in Tank P? Give your answer in litres.

Ans : (a) _____ [1]

(b) _____ [2]

10. Mr Min and Mr Yong received a total of \$1026. After Mr Min spent $\frac{6}{7}$ of his money and Mr Yong spent $\frac{3}{4}$ of his money, Mr Yong had 3 times as much money as Mr Min. How much money did Mr Yong have at first?

Ans : _____ [3]

11. The bar graph shows the number of hampers sold by a gift shop from January to May. The bar for the month of May has not been drawn.

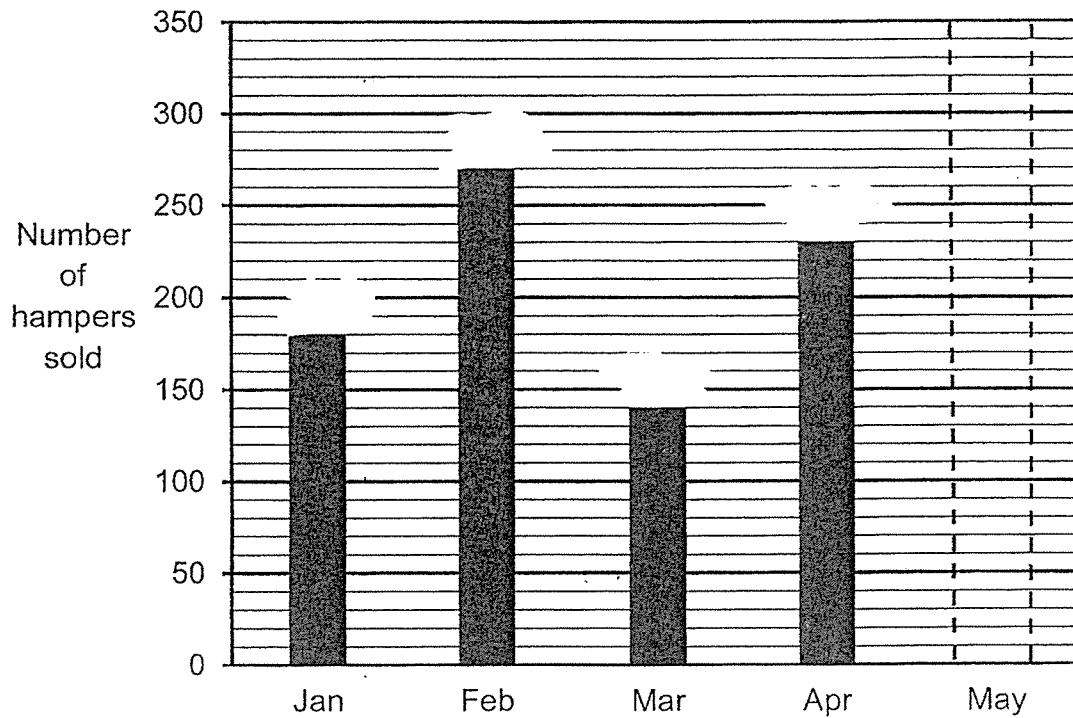

- (a) The number of hampers sold in May was 35 less than the average number of hampers sold per month from January to April. How many hampers was sold in May?
- (b) The gift shop set a goal to sell an average of 220 hampers per month from January to June. What was the minimum number of hampers that must be sold in June in order to reach the goal?

Ans : (a) _____ [2]

(b) _____ [2]

12. In the figure, AB is a straight line. CAF is an isosceles triangle, BCF is a triangle and CDGB is a rectangle. $\angle ECD = 22^\circ$ and $\angle AFC = 82^\circ$.

Find the value of

- (a) $\angle FCB$
 (b) $\angle FBC$

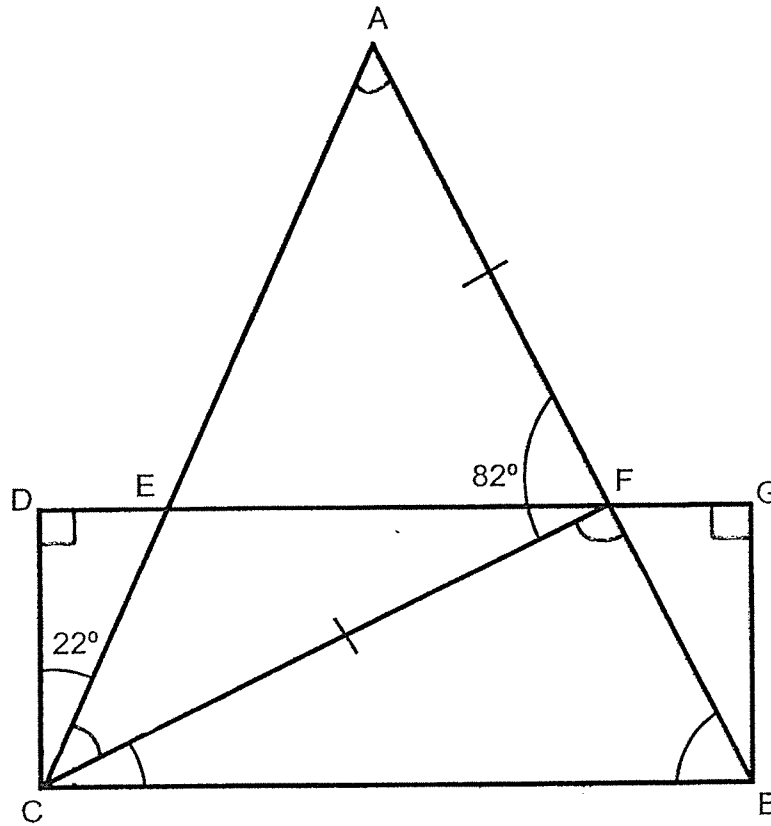

Ans : (a) _____ [2]

(b) _____ [2]

13. A florist sold carnations and roses in her shop on Mother's Day. 60% of the flowers she sold on that day were carnations and she sold 480 roses.

(a) What was the total number of flowers sold?

(b) 80% of the flowers in the shop were sold on that day. 85% of the flowers left were roses. How many roses were left?

Ans : (a) _____ [2]

(b) _____ [2]

14. The diagrams below show a pattern made up of squares.

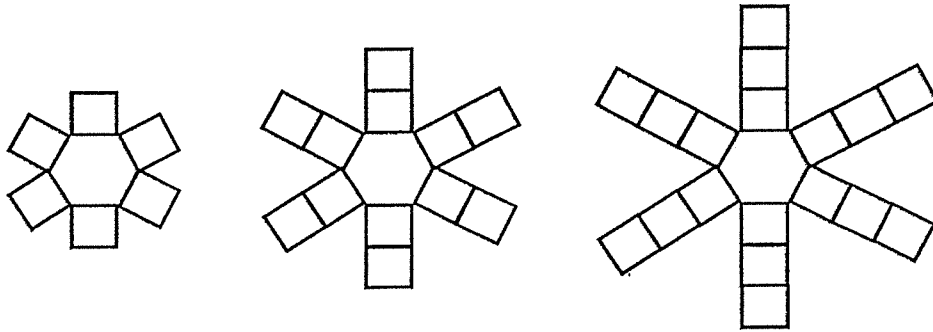

Pattern 1

Pattern 2

Pattern 3

Pattern Number	Number of squares	Number of sides
1	6	18
2	12	30
3	18	42
4	24	54
5	a) ?	b) ?

- (a) How many squares are there in Pattern 5?
 (b) How many sides are there in Pattern 5?
 (c) What is the Pattern Number for 246 sides?

Ans : (a) _____ [1]

(b) _____ [1]

(c) _____ [2]

15. There were a total of 2350 blue and red beads in a box. The ratio of the number of blue beads to the number of red beads was 3 : 2. After Sammy added some green beads into the box, the ratio of the number of blue beads to the number of green beads became 2 : 5.

(a) How many blue beads were there in the box?

(b) What was the total number of beads in the box in the end?

Ans : (a) _____ [2]

(b) _____ [3]

16. In the figure, ABC is a right-angled triangle and CDEF is a square. ED is three times as long as AF.

(a) Find the area of triangle ABC.

(b) Find the area of the shaded part.

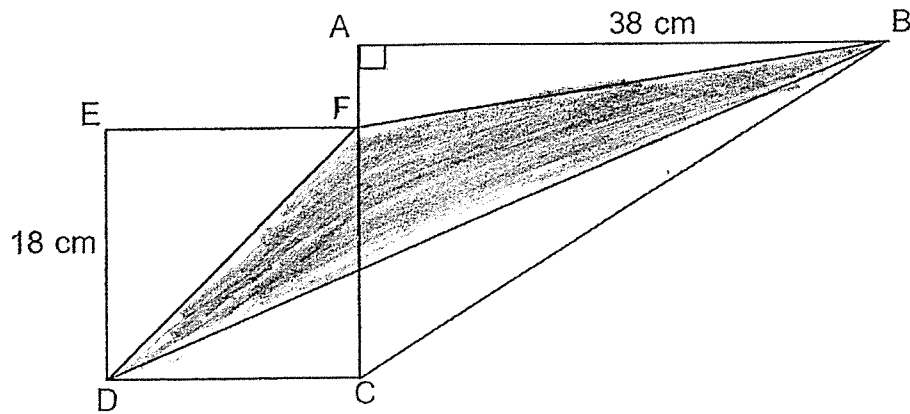

Ans : (a) _____ [1]

(b) _____ [4]

17. Kelly bought a piece of fabric. She used 9.2 m to sew 4 aprons and 5 kitchen towels. She wanted to sew another apron but was short of 0.3 m of fabric. In the end, she sewed another kitchen towel and had 0.38 m of fabric left.
- (a) What was the difference in the length of the fabric needed to sew an apron and a towel? Give your answer in metres.
- (b) How many metres of fabric did Kelly buy?

Ans : (a) _____ [1]

(b) _____ [3]

End of Paper

☺ Please check your work carefully ☺

ANSWER KEY

YEAR : 2021
 LEVEL : PRIMARY 5
 SCHOOL : RAFFLES GIRLS' PRIMARY SCHOOL
 SUBJECT : MATHEMATICS
 TERM : SA2

BOOKLET A (PAPER 1)

Q1	2	Q2	1	Q3	3	Q4	3	Q5	2
Q6	2	Q7	3	Q8	2	Q9	2	Q10	2
Q11	4	Q12	1	Q13	1	Q14	2	Q15	3

BOOKLET B (PAPER 1)

Q16	$(12 + 36) \div 8 \times 6$ $= 48 \div 8 \times 6$ $= 6 \times 6$ $= 36$	Q17	$26 \div 4 = \frac{26}{4}$ $= 6\frac{2}{4}$ $= 6\frac{1}{2}$
Q18	89.06cm = 89.06m	Q19	$\frac{5}{6} - \frac{3}{4} = \frac{10}{12} - \frac{9}{12} = \frac{1}{12}$
Q20	$118^\circ - 13^\circ = 105^\circ$	Q21	(a) $5.7 \div 100 = 0.057$ (b) $0.23 \times 3000 = 0.230 \times 1000 \times 3$ $= 230 \times 3$ $= 690$
Q22	(a) $7 \times 3 = 21$ (b) $3 \times 6 = 18$	Q23	$54 - 9 = 45$ pupils $45 \times 2 = 90$ $90 \div 9 = 10$
Q24	$\frac{1}{2} \times 14 \times 10 = 70$ $\frac{1}{2} \times 10 \times 10 = 50$ $50 + 70 = 120\text{cm}^2$	Q25	$\frac{5}{9} + \frac{1}{12} = \frac{20}{36} + \frac{3}{36} = \frac{23}{36}$ $36U = \$36$ $1U = \$1$ $13U = 13 \times 1 = \$13$
Q26	$\frac{1}{6} \rightarrow 250\text{g}$ $\frac{1}{3} = \frac{2}{6} \rightarrow 340\text{g}$ $\frac{1}{6} \rightarrow 340 - 250 = 90$ $250 - 90 = 160\text{g}$	Q27	$160 - 25 = 135$ $60\% = \frac{3}{5}$ $5U = 135$ $1U = 135 \div 5 = 27$ $2U = 27 \times 2 = 54$
Q28	$4U = 24$ $1U = 24 \div 4 = 6$	Q29	$20 \text{ min} \rightarrow 96 \ell$ $1 \text{ min} \rightarrow 96 \div 20$

	$5U = 6 \times 5 = 30$ $3P = 24$ $1P = 24 \div 3 = 8$ $30 - 8 = 22$		$= 9.6 \div 10 \div 2$ $= 9.6 \div 2$ 4.8 $7 \text{ min} \rightarrow 4.8 \times 7 = 33.6\ell$
Q30	(a) Impossible to tell (b) False (c) False		

PAPER 2

Q1	$1^{\text{st}} \text{ hour} = \8 $\text{Next } 2\text{h}15\text{min} = \$1.10 \times 5 = \$5.5$ $\$5.50 + \$8 = \$13.50$	Q2	$100\% = \$880$ $1\% = \$8.80$ $107\% = \$8.80 \times 107$ $= \$941.60$
Q3	$\$0.60 \times 4 = \2.40 $\$4.60 - \$2.40 = \$2.20$	Q4	$20 \div 9 = 2\frac{2}{9}$ $7 \times 2\frac{2}{9} = 15\frac{5}{9} \text{ kg}$
Q5	$60^\circ - 11^\circ = 49^\circ$ $180^\circ - (49^\circ + 49^\circ)$ $= 180^\circ - 98^\circ$ $= 82^\circ$	Q6	(a) $28U = 11060$ $1U = 11060 \div 28 = 395$ $1 \text{ adult} + 3 \text{ children}$ $= 10 + 6 + 6 + 6 = \$28$ (b) $4U = 395 \times 4 = 1580$
Q7	(a) length of B = $60 \div 4 = 15$ Area of B = $15 \times 15 = 225\text{cm}^3$ (b) $5U = 15$ $1U = 15 \div 5 = 3$ Length of A = $3 \times 2 = 6$ Area of A = $6 \times 6 = 36$ A:B = 4:25	Q8	$5U = 45$ $1U = 45 \div 5$ $= 89$ $3U = 89 \times 3$ $= 267$
Q9	(a) $\frac{7}{9} \times 36 \times 36 \times 36 = 36288\text{cm}^3$ (b) $50 \times 18 \times 26 = 23400$ $36288 - 23400 = 12888$ $12888 \text{ ml} = 12.888\ell$	Q10	$\frac{3}{7} m = \frac{1}{4} y$ $\frac{3}{7} m = \frac{3}{12} y$ $m = 7U$ $y = \frac{12u}{19u}$ $19U = 1026$ $1U = 1026 \div 19 = 54$ $12U = 54 \times 12 = \$648$
Q11	(a) $180 + 270 + 140 + 230 = 820$ $820 \div 4 = 205$ $205 - 35 = 170$ (b) $220 \times 6 = 1320$ $820 + 170 = 990$ $1320 - 990 = 330$	Q12	(a) $(180^\circ - 82^\circ) \div 2$ $= 98^\circ \div 2$ $= 49^\circ$ $180^\circ - 82^\circ = 98^\circ$ $90^\circ - 49^\circ - 22^\circ = 19^\circ$ (b) $180^\circ (19^\circ + 98^\circ) = 63^\circ$

Q13	<p>(a) $2U = 480$ $1U = 480 \div 2 = 240$ $5U = 240 \times 5 = 1200$ (b) $80P = 1200$ $1P = 1200 \div 80 = 15$ $17P = 15 \times 17 = 255$</p>	Q14	<p>(a) $24 + 6 = 30$ (b) $54 + 12 = 66$ (c) $12n + 6 = 246$ $246 - 6 = 240$ $240 \div 12 = 20$</p>
Q15	<p>(a) $10U = 2350$ $1U = 2350 \div 10 = 235$ $6U = 235 \times 6 = 1410$ (b) $25U = 235 \times 25 = 5875$</p>	Q16	<p>(a) $3U = 18$ $1U = 18 \div 3 = 6$ $18 + 6 = 24$ $\frac{1}{2} \times 24 \times 38 = 456\text{cm}^2$ (b) $\frac{1}{2} \times 18 \times 18 = 162$ $\frac{1}{2} \times 6 \times 38 = 114$ $\frac{1}{2} \times 18 \times 24 = 216$ $162 + 114 + 216 = 492$ $18 \times 18 = 324$ $324 + 456 = 780$ $780 - 492 = 288\text{cm}^2$</p>
Q17	<p>(a) $0.3 + 0.38 = 0.68\text{m}$ (b) $9U + 2.72 = 9.2$ $9U = 6.48$ $1U = 6.48 \div 9 = 0.72$ $0.72 + 9.2 + 0.38 = 10.3\text{m}$</p>		