



2021 PRIMARY 4 NON-WEIGHTED PRACTICE PAPER

Name : _____ ()

Date: _____

Class : Primary 4 ()

Time: 8.00 a.m. - 9.30 a.m.

Parent's signature: _____

Duration: 1 hour 30 minutes

SCIENCE

BOOKLET A

INSTRUCTIONS TO CANDIDATES

1. Write your name, class and register number.
2. Do not turn over this page until you are told to do so.
3. Follow all instructions carefully.
4. Answer all questions.
5. Shade your answers on the Optical Answer Sheet (OAS) provided.

Booklet A (22 x 2 marks)

For each question from 1 to 22, four options are given. One of them is the correct answer. Make your choice (1, 2, 3 or 4) and shade your answer on the Optical Answer Sheet.

(44 marks)

1. The diagram below shows a plant.

Which part (1), (2), (3) or (4) is the leaf?

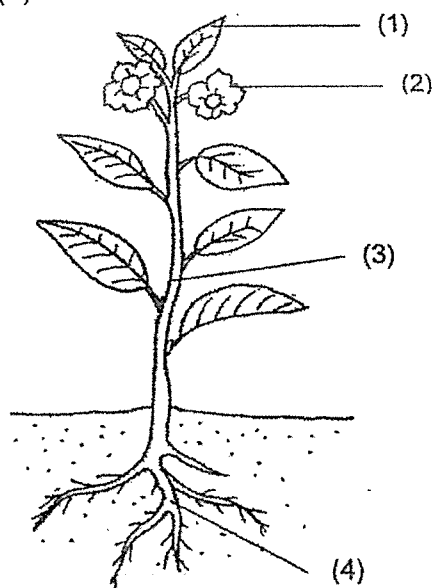

2. In which part of the digestive system is the digested food absorbed into the blood?
- (1) gullet
 - (2) mouth
 - (3) small intestine
 - (4) large intestine

3. Animal A hides itself in its shell when touched.

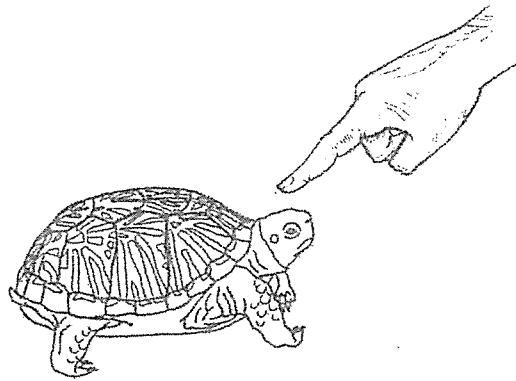

Animal A

This shows that Animal A is a living thing because it can _____.

- (1) grow
 - (2) breathe
 - (3) respond
 - (4) reproduce
4. The diagram below shows the life cycle of an animal.

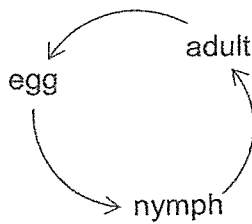

Which animal below has a similar life cycle to the one shown above?

- (1) frog
- (2) beetle
- (3) caterpillar
- (4) grasshopper

5. The graph below shows the number of weeks in the different stages of the life cycle of animal T.

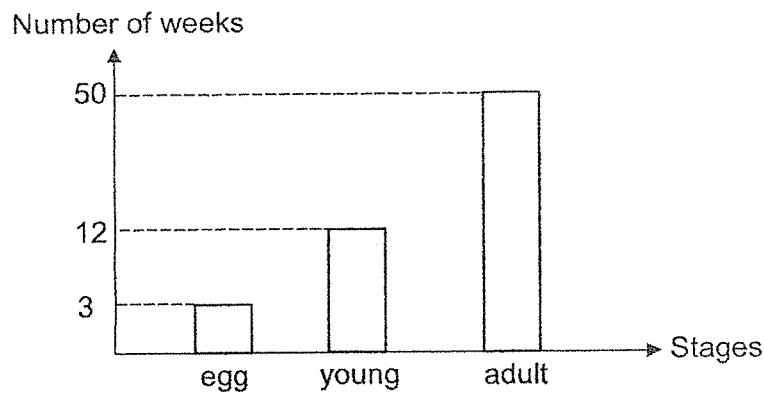

Based on the graph above, how many weeks will it take for animal T's egg to become an adult after it is laid?

- (1) 12 weeks
(2) 15 weeks
(3) 50 weeks
(4) 65 weeks
-
6. Which of the following body systems in our body are needed when we swim?
- A. Skeletal system
B. Muscular system
C. Circulatory system
D. Respiratory system
- (1) A and B only
(2) C and D only
(3) B, C and D only
(4) A, B, C and D

7. Mark carried out an experiment to find out how various conditions given affect the growth of plants, A, B and C. The table below shows the conditions in which the plants are grown.

Plant	A	B	C
Duration of plant exposed to light (hours)	8	8	4
Amount of water given per day (ml)	80	40	80

Which pair of plants should Mark compare to find out the following?

	To find out how amount of light affects plant growth	To find out how amount of water affects plant growth
(1)	A and C	A and B
(2)	A and C	B and C
(3)	B and C	A and C
(4)	B and C	A and B

8. Which one of the following substances has a fixed shape?

- (1) air
- (2) oil
- (3) ice
- (4) water

9. Look at the picture below.

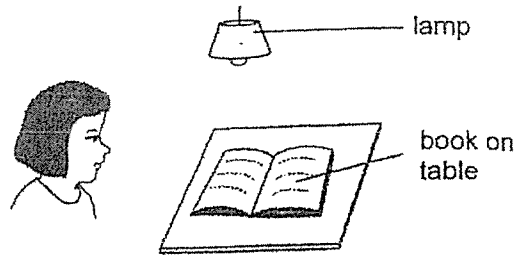

Which of the following explains why Laura can see the book on the table?

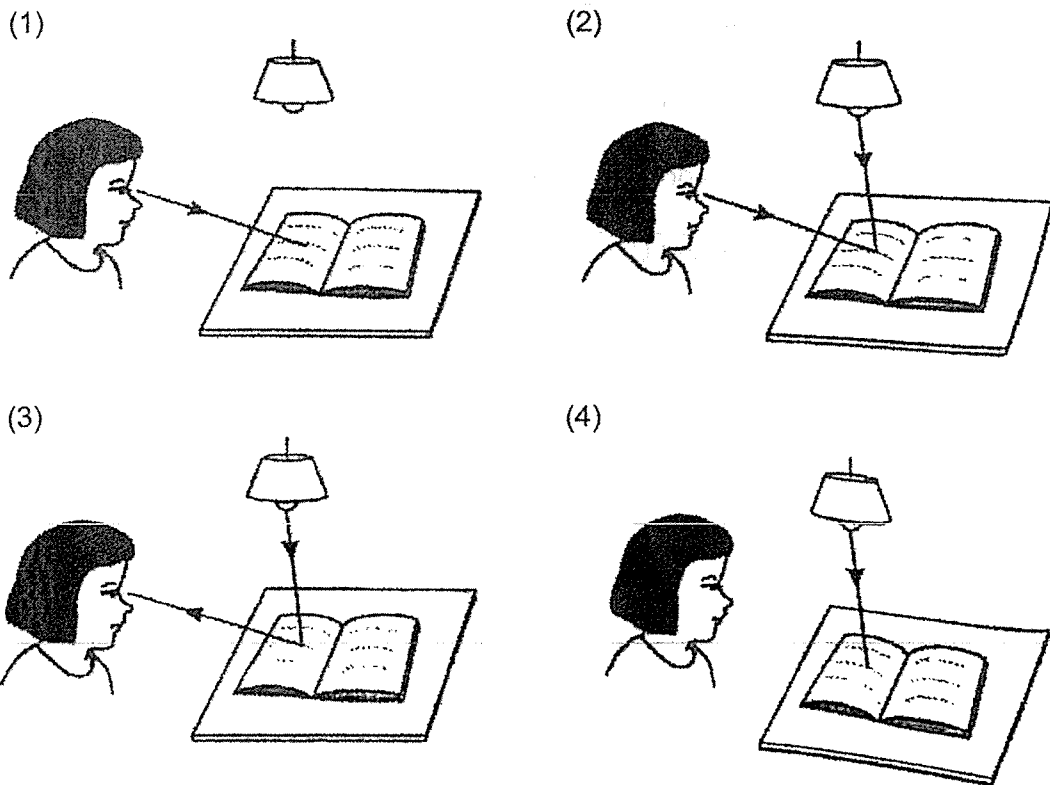

10. Which one of the following is **NOT** a source of heat?

- (1) a fire
- (2) the Sun
- (3) a lighted lamp
- (4) a pair of socks

11. Faizal places a metal spoon in a bowl of hot soup.

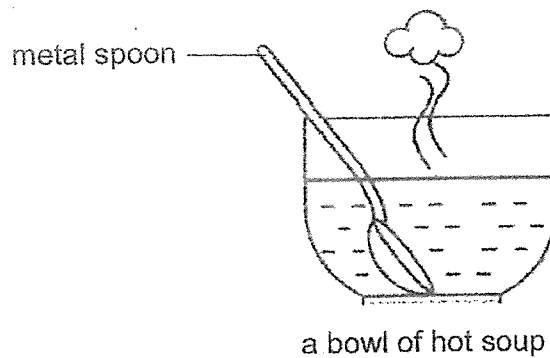

The metal spoon becomes hotter after a while. Which of the following explains this?

- (1) The bowl loses heat to the hot soup.
- (2) The hot soup gains heat from the bowl.
- (3) The metal spoon loses heat to the hot soup.
- (4) The metal spoon gains heat from the hot soup.

12. Lucas put a styrofoam block into a container of water. At which position, A, B, C or D, would the block most likely be found?

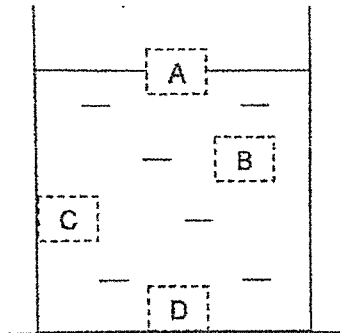

- (1) A
- (2) B
- (3) C
- (4) D

13. A measuring cylinder shown below contains 150 cm³ of water. Object X was dropped into the measuring cylinder and 50 cm³ of oil was poured in.

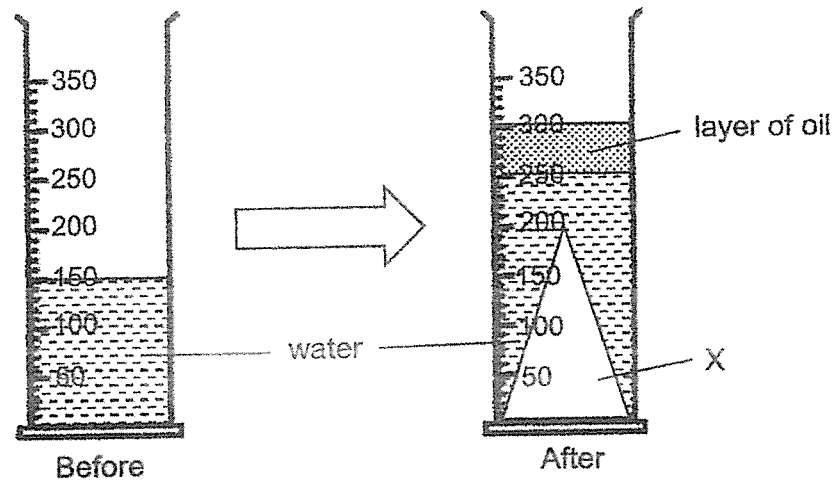

What does the above set-up show about the properties of solids and liquids?

- (1) Solids do not have a fixed volume.
- (2) Liquids do not have a fixed volume.
- (3) Solids and liquids have a fixed volume.
- (4) Solids have a fixed volume but liquids do not have a fixed volume.

14. Wei Sheng has 4 identical plastic cups. He poked holes into the cups, turned them upside down, and submerged them into a container of water. Which diagram shown below is a possible outcome?

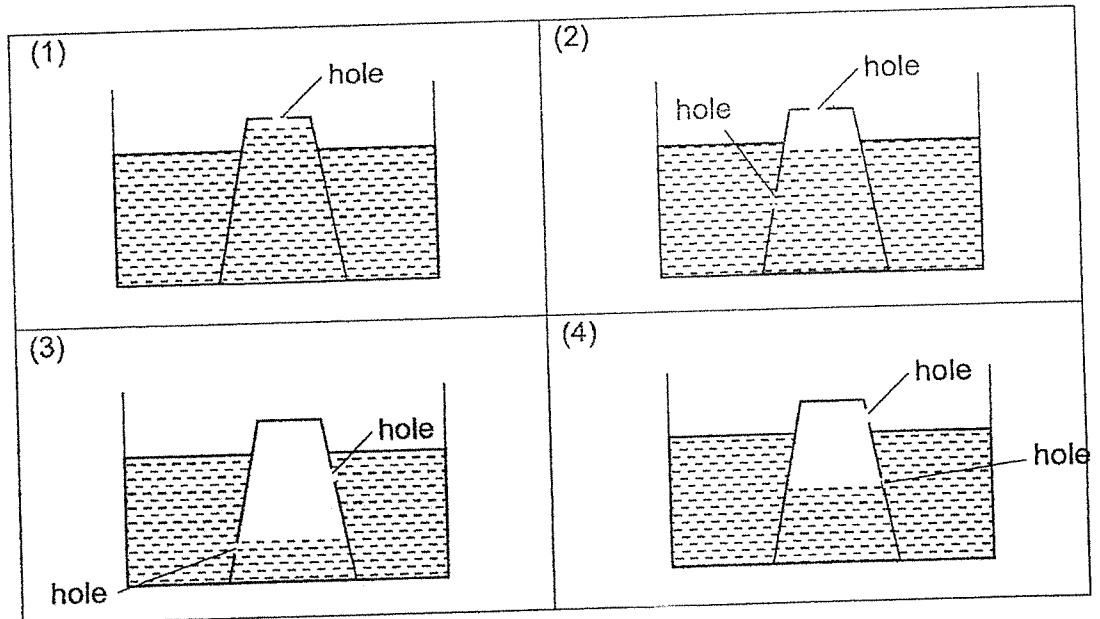

15. We can see a book because it _____.

- (1) gives out its own light
- (2) blocks light from light sources
- (3) reflects light from the Sun
- (4) takes in light from the Sun

16. The table below shows the properties of 4 materials, A, B, C and D.

Allows most light to pass through	Allows no light to pass through
A	C
B	D

The diagram below shows a lit room separated by walls made from the materials A, B, C and D.

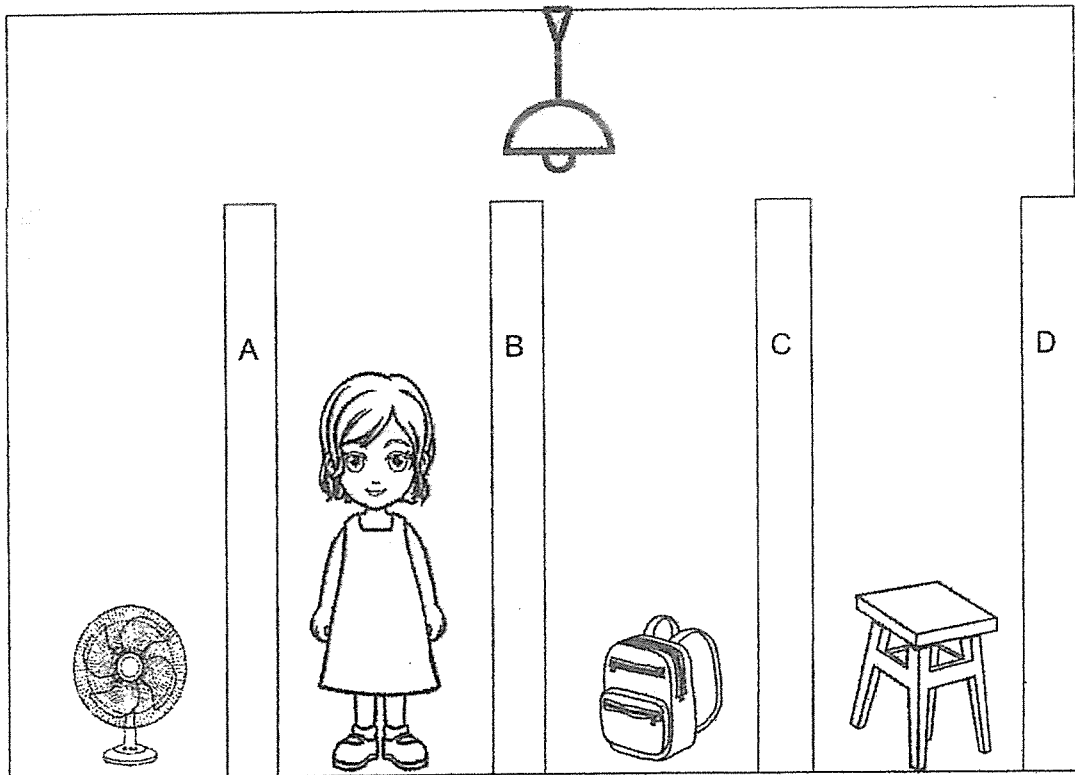

How many object(s) placed behind the walls can the girl see?

- (1) 1
- (2) 2
- (3) 3
- (4) 0

17. The diagram below shows an object X casting a shadow on a fixed screen.

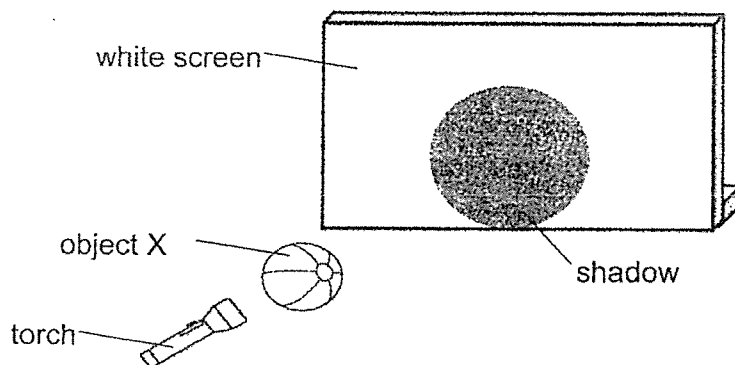

Using the same torch and object, how can a larger shadow be formed?

- (1) Move the object nearer to the torch.
 - (2) Move the object nearer to the screen.
 - (3) Move the screen nearer to the object.
 - (4) Move the torch further from the screen.
18. Observe the set-up below.

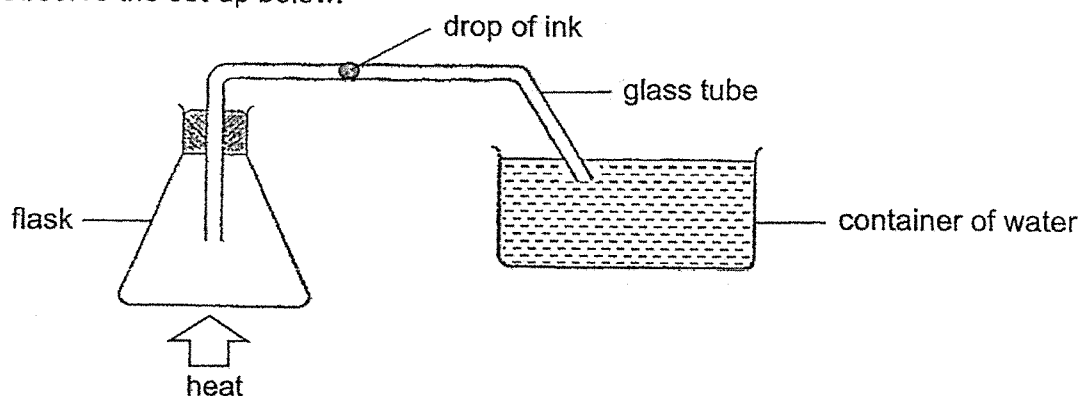

Which of the following is a possible observation when the bottom of the flask is heated?

- (1) Water enters the glass tube.
- (2) The drop of ink moves to the left.
- (3) The water level in the container drops.
- (4) Bubbles come out from the glass tube.

19. Mr Singh left 4 identical spoons made of different materials, Q, R, S and T in the freezer overnight. Next morning, he took them out of the freezer and left them in the Sun. After 5 minutes, he recorded the temperatures of the spoons. The results are shown in the table below.

Material	Temperature after 5 minutes in the Sun (°C)
Q	34
R	15
S	10
T	27

Which material, Q, R, S or T, would be most suitable to make a container for keeping food warm the longest time?

- (1) Q
- (2) R
- (3) S
- (4) T

20. Hui Ling has 4 bowls, A, B, C and D, made of different materials. The bowls are of the same size and thickness. She placed an identical ice cube in each bowl and heated the bowls over a flame for 7 minutes as shown below.

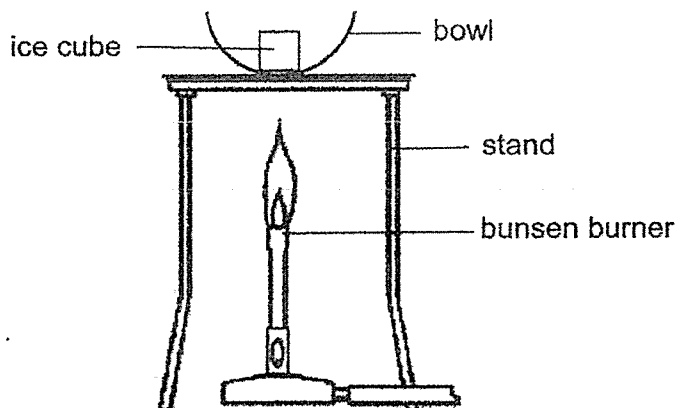

She recorded her observations in the table below.

Bowl	State of the ice cube after		
	3 minutes	5 minutes	7 minutes
A	liquid	liquid	gas
B	solid	liquid	liquid
C	liquid	liquid	liquid
D	solid	solid	solid

Which bowl is the best conductor of heat?

- (1) A
- (2) B
- (3) C
- (4) D

21. In which of the following will the two magnets push each other away?

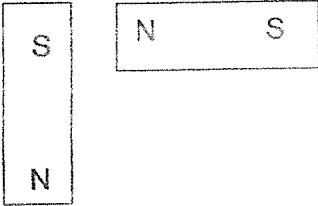
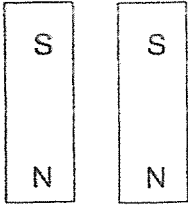
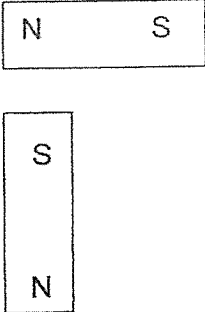
1	
2	
3	
4	

22. Study the following observations of magnets, X, Y and Z interacting with two identical paper clips and identical sheets of paper.

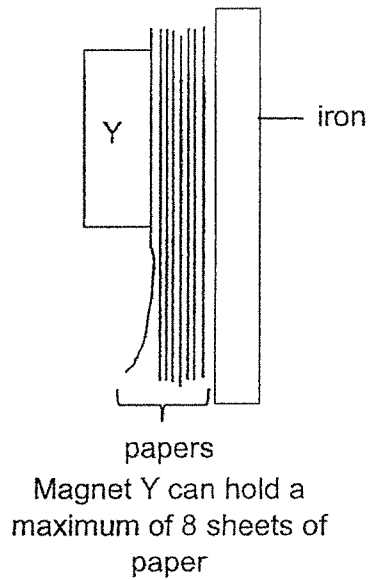
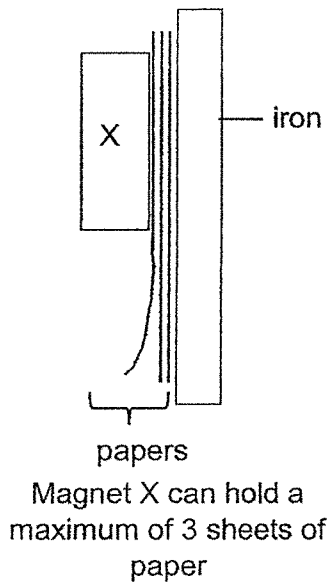
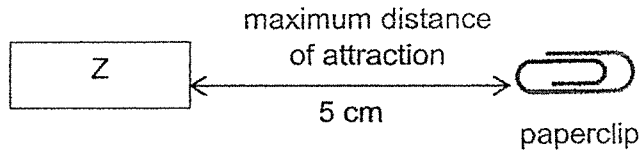
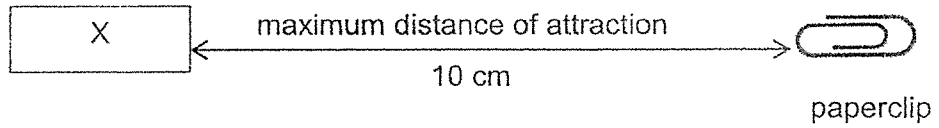

Which arrangement of magnets X, Y and Z, shows the weakest magnet to the strongest magnet?

- (1) X, Y, Z
- (2) Y, X, Z
- (3) Z, Y, X
- (4) Z, X, Y

End of Booklet A



2021 PRIMARY 4 NON-WEIGHTED PRACTICE PAPER

Name : _____

Date: _____

Class : Primary 4 (

Time: 8.00 a.m. – 9.30 a.m.

Parent's Signature : _____

Duration: 1 hour 30 minutes

SCIENCE

BOOKLET B

INSTRUCTIONS TO CANDIDATES

1. Write your name, class and register number.
2. Do not turn over this page until you are told to do so.
3. Follow all instructions carefully.
4. Answer all questions.
5. Write your answers in the booklet.

Booklet A	44
Booklet B	36
Total	80

Booklet B (36 marks)

For questions 23 to 34, write your answers clearly in this booklet. The number of marks available is shown in brackets [] at the end of each question or part question.

(36 marks)

23. The diagram below shows the stages in the life cycle of a mosquito.

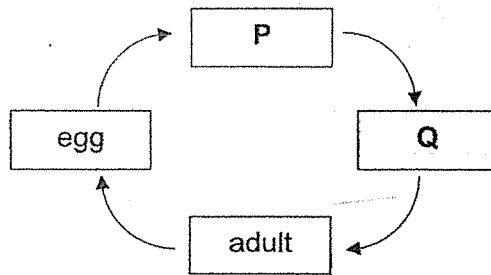

Choose the correct words from the box to answer the question below.

seed	pupa	larva	nymph
------	------	-------	-------

Name the two stages, **P** and **Q**.

[2]

P: _____

Q: _____

Score	2
-------	---

24. Study the diagram below.

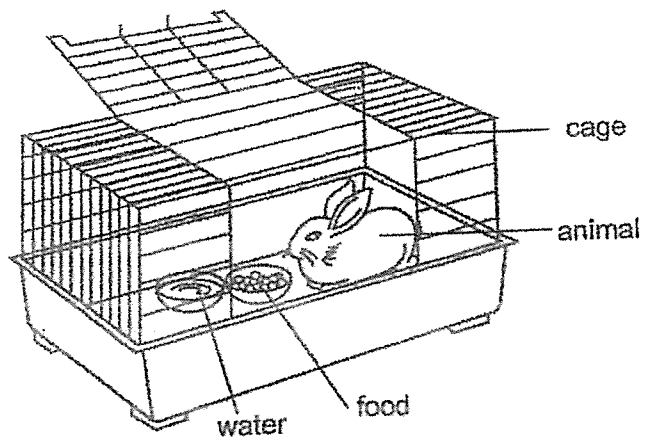

(a) After a few days, will the amount of water in the bowl increase, decrease or remain the same? [1]

(b) Based on the diagram above, name one substance this animal needs so it remains alive. [1]

Score	2
-------	---

25. The diagram below shows two plants.

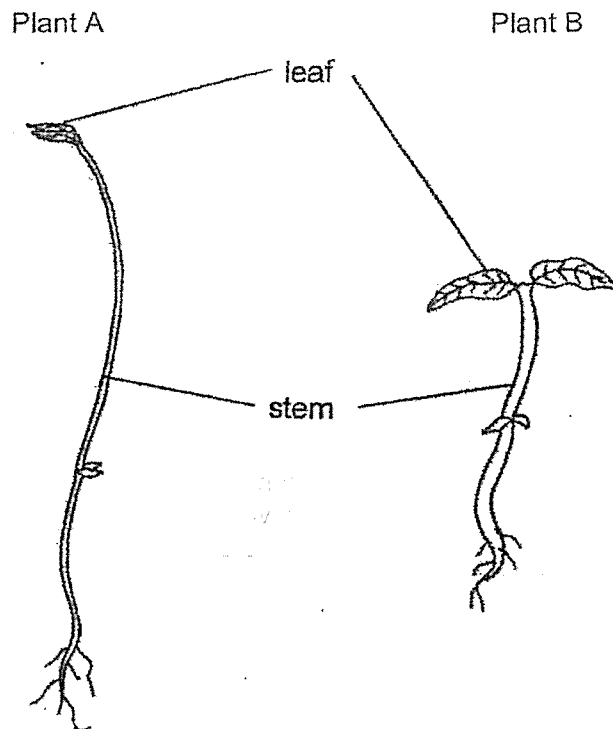

(a) What is one difference between the stem of plant A and the stem of plant B? [1]

The stem of plant A is _____ than the stem of plant B.

(b) The leaves help both plants make _____ in the light. [1]

(c) The roots help both plants absorb _____ and mineral salts from the soil. [1]

Score	3
-------	---

26. Jamie was eating rice with a pair of chopsticks.

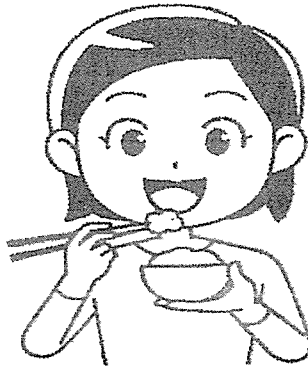

Jamie took one mouthful of rice and chewed 10 times before swallowing. She then took another mouthful of rice and chewed 20 times before swallowing.

(a) How does increasing number of times she chewed in her mouth affect the amount of undigested food before swallowing? [1]

(b) Explain your answer in part (a). [1]

Jamie started talking to her father as she was swallowing the rice. She choked and started to cough.

(c) Which body system had the rice gone into which had caused Jamie to cough? [1]

(d) Which is the correct body system for the rice to go into after swallowing? [1]

Score	4
-------	---

27. Devi planted 20 identical seeds in each of the four identical containers, A, B, C and D, and placed them at different locations. She watered the seeds with the same amount of water every day and recorded the number of seeds germinated in each container after 3 days in the table below.

Container	Temperature of the surroundings (°C)	Number of seeds germinated after 3 days
A	10	1
B	20	10
C	30	15
D	40	0

- (a) Based on the table above, what is the aim of Devi's experiment? [1]

To find out how _____

- (b) Based on the information above, what is the most suitable temperature in order for the most number of seeds to germinate? [1]

- (c) When the temperature of the surroundings is 40 °C, no seeds germinated. Explain why. [1]

Score	3
-------	---

28. The picture below shows an inflated balloon.

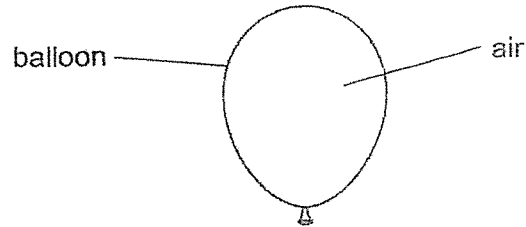

Circle the correct state for the following things.

[2]

(a) air: solid / liquid / gas

(b) balloon: solid / liquid / gas

29. Kate placed two ring magnets, A and B, through a holder as shown below.

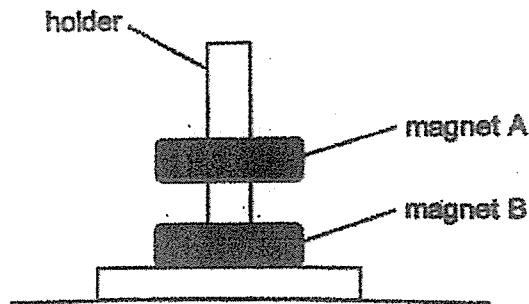

(a) The holder was made of plastic and was not attracted by the magnets.

Plastic is a _____ material.

[1]

(b) Why was magnet A floating above magnet B?

Magnet B was _____ magnet A.

[1]

Score	4
-------	---

30. Jordan wanted to compare the volume of three objects, W, X and Y. He dropped each object into three identical test-tubes with different amounts of water. The diagram below shows the experiment.

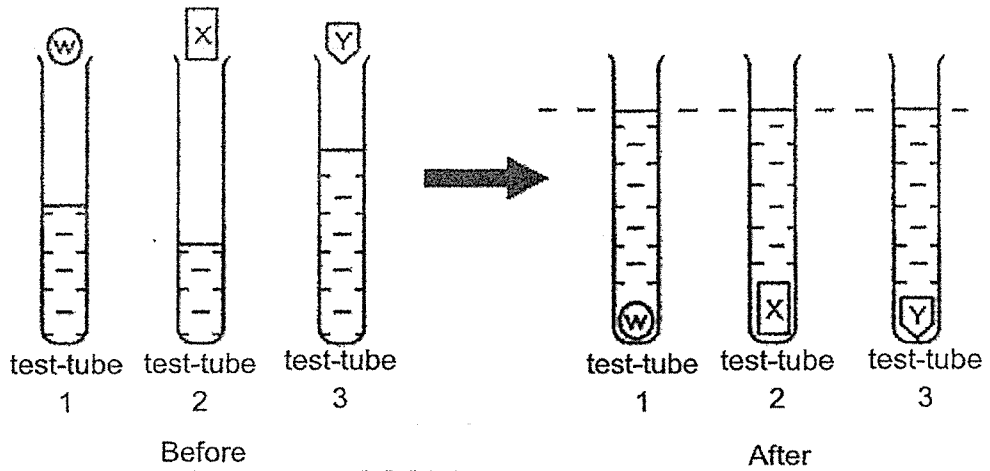

The water level at the end is the same for all three test-tubes. Jordan concluded that the three objects have the same volume. However, Jordan's classmate said that the volume of X is greater than the volume of Y

- (a) Whose conclusion is correct? Explain why. [1]

- (b) Based on the above experiment, complete the table below by arranging the volumes of the objects, W, X and Y from smallest to largest. [1]

Volume	Smallest volume \longrightarrow Largest volume		
Object			

Score	2
-------	---

Jordan measured the volume of water in the containers using a measuring cylinder as shown below.

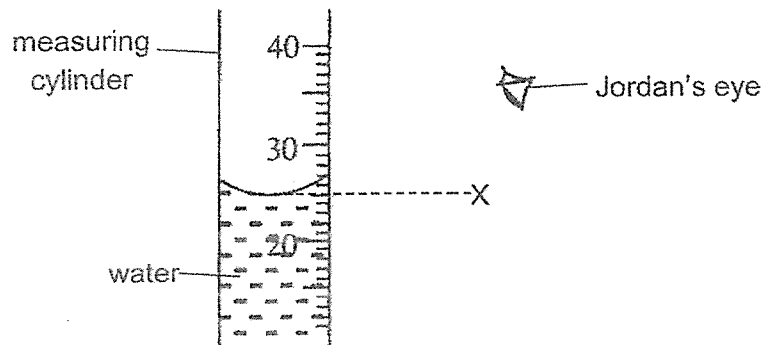

Jordan's teacher said that Jordan should read the water level from position X.

(c) Explain how reading from position X would affect Jordan's readings. [1]

Jordan could not fit his bag of clothes shown below into a suitcase.

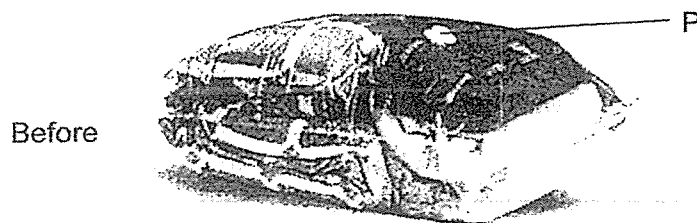

After air had been sucked out from opening P, he was then able to fit the bag of clothes in as shown below.



(d) Explain why. [1]

Score	2
-------	---

31. The diagram below shows 4 different shapes cut from sheets made of different materials, P, Q, R and S. All of the shapes are of the same height, 5cm.

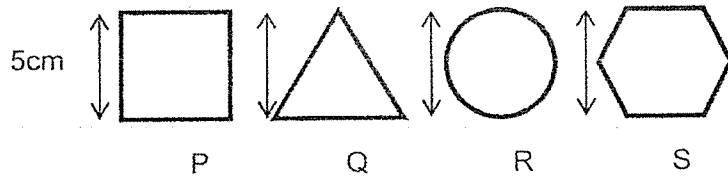

The shapes were then arranged in a straight line as shown in the diagram below. A torch was then shone at the shapes as shown.

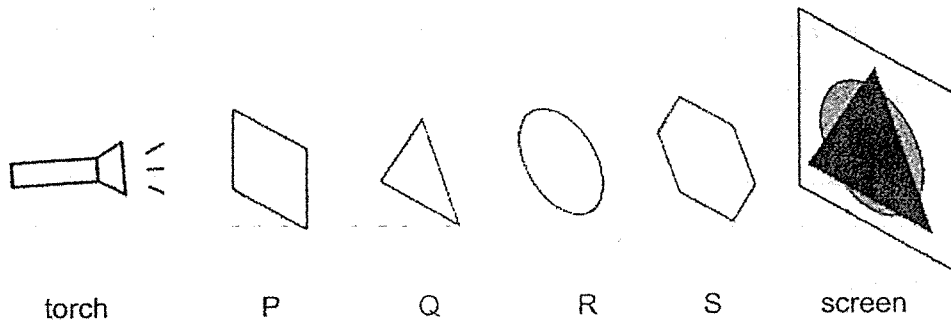

A shadow as shown above was observed on the screen.

- (a) Based on the above, state "most", "some" or "no" for the blanks provided below to describe the properties of the material P, Q, R and S. [2]

P: allows _____ light to pass through

Q: allows _____ light to pass through

R: allows _____ light to pass through

S: allows _____ light to pass through

Score	2
-------	---

One of the materials P, Q, R and S, was used to make the front of a toy box as shown in the diagram below.

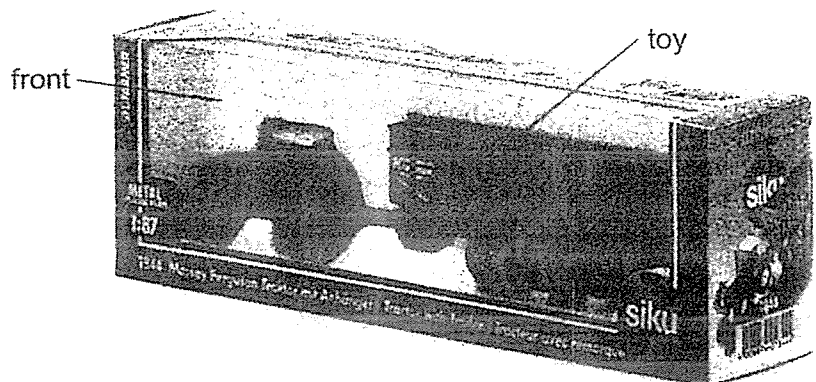

(b) Based on the results of the experiment, which material, P, Q, R or S, is the most suitable for making the front of the toy box? Explain why. [2]

Score	2
-------	---

32. Ivan walked from point A to point B under a lighted lamppost on a dark night as shown below.

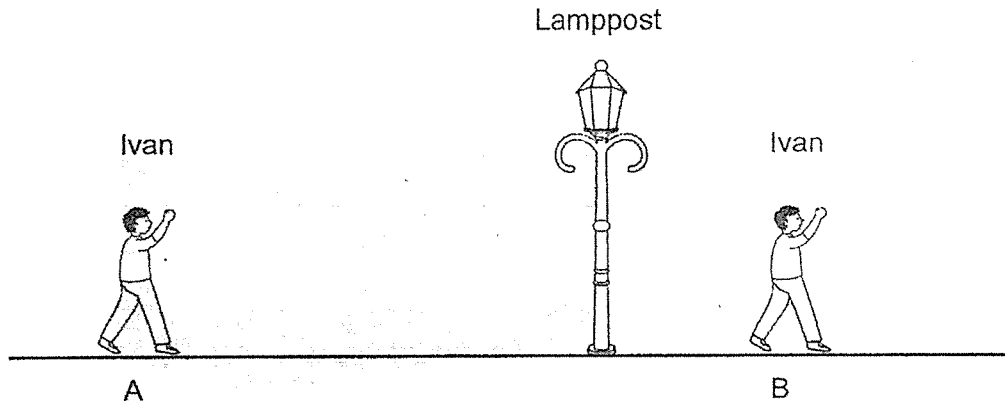

(a) How is Ivan's shadow formed? [1]

(c) Draw in the bar graph to show the length of Ivan's shadow when he is at position B. [1]

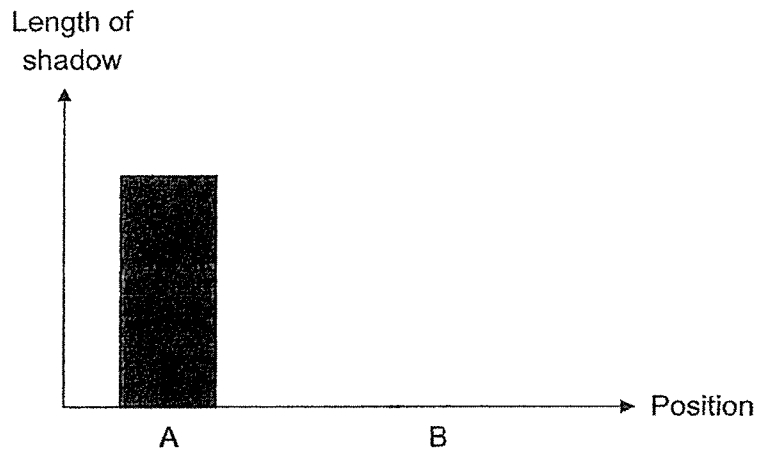

Score	2
-------	---

33. John has two containers, J and K, made of different materials as shown below. The containers are of the same size, shape and thickness. He poured boiling water into the containers and left them in a room at room temperature. He measured the temperature of the water after 1 hour.

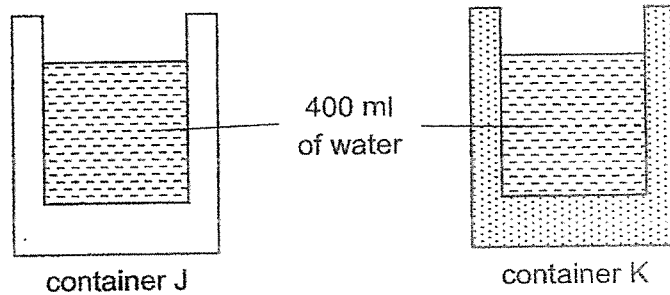

He recorded the temperatures of the water in the table below.

Container	Start temperature (°C)	End temperature after 1 hour (°C)
J	100	60
K	100	40

- (a) Which container should John use if he wants to bring a tub of ice cream to his friend who lives 1 hour away? Explain why. [2]

John then set the temperature of the room to 18 °C and left the two containers of water in the room overnight for 8 hours.

- (b) What will be the temperature of the water in the containers the next day? Explain your answer. [2]

34. Four rods made of different metals, P, Q, R and S, are heated over a flame. The rods have the same length and thickness. The change in the length of the rods as they are heated is shown in the graph below.

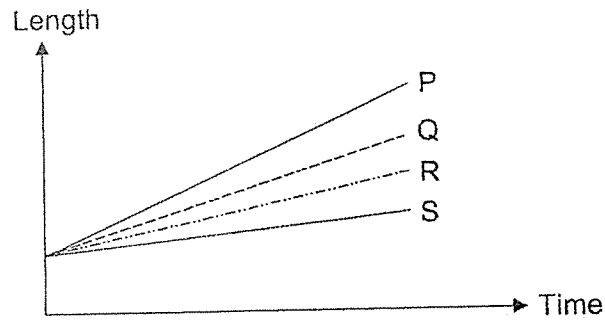

- (a) Explain why the length of the rods increased. [1]

Railway tracks are built with gaps in between the rails of the tracks.

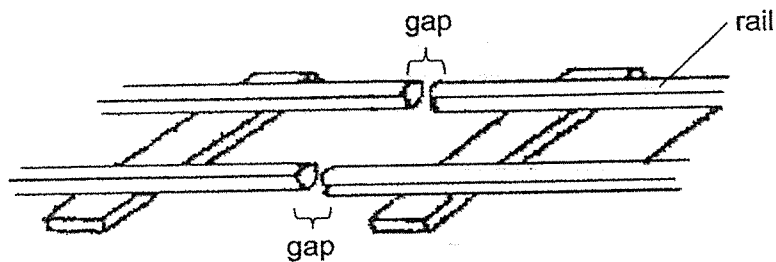

- (b) What is the purpose of the gap between the rail? [1]

- (c) What would happen to the track if there are no gaps between the rails? [1]

Score	3
-------	---

(d) Which metal, P, Q, R or S, is most suitable for making the tracks? Based on the results from the graph, explain why. [1]

End of Paper

Score	1
-------	---



ANSWER KEY

YEAR : 2021
 LEVEL : Primary 4
 SCHOOL : Tao Nan School
 SUBJECT : SCIENCE
 TERM : Non-Weighted Practice Paper

BOOKLET A

Q1	1	Q2	3	Q3	3	Q4	4	Q5	2
Q6	4	Q7	1	Q8	3	Q9	3	Q10	4
Q11	4	Q12	1	Q13	3	Q14	2	Q15	3
Q16	2	Q17	1	Q18	4	Q19	3	Q20	1
Q21	3	Q22	4						

BOOKLET B

Q23	P : Larva Q : Pupa
Q24	(a) After a few days, the amount of water in the bowl decrease. (b) food
Q25	(a) taller (b) food (c) water
Q26	(a) The amount of undigested food decreased. (b) It increases the surface area of the rice for digestion. (c) Respiratory system (d) Digestive system
Q27	(a) To find out how the temperature of the surroundings affects the number of seeds germinated after 3 days. (b) 30°C (c) It is because the temperature was too high for the seeds to germinate.
Q28	(a) gas (b) solid
Q29	(a) non-magnetic (b) repelling
Q30	(a) Jordan's classmate's conclusion is correct. The increase in the water level is greater for X. (b) Y, W, X (c) It is because when looking at position X it will give the accurate amount

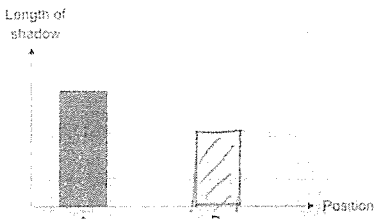
	<p>of water in the measuring cylinder.</p> <p>(d) There is no air in the bag, so the bag of clothes took up less space.</p>
Q31	<p>(a) P : most Q : no R : some S : most</p>
Q32	<p>(a) It is formed by Ivan blocking the light from the lamppost.</p>  <p>(b)</p> <p>(c) Material P. It is because material P allows most light to pass through so people can see the toy inside the box.</p>
Q33	<p>(a) It is because container J is a poorer conductor of heat so the ice cream will gain heat slower from the surrounding and the ice cream melts slower.</p> <p>(b) The water lost heat to its surroundings, unless both reach the same temperature.</p>
Q34	<p>(a) It is because the heat from the flame made the rod expand.</p> <p>(b) To let the rail expand on a hot day without buckling.</p> <p>(c) The tracks would bend sideways.</p> <p>(d) Metal S. It is because Metal S expanded the least when flame was heating S.</p>

2
ZND