



## 2021 PRIMARY 4 MID-YEAR EXAMINATION

Name : \_\_\_\_\_ ( )

Date: 11 May 2021

Class : Primary 4 ( )

Time: 8.00 a.m. - 9.30 a.m.

Parent's Signature: \_\_\_\_\_

Duration: 1 hour 30 minutes

# SCIENCE

## BOOKLET A

### INSTRUCTIONS TO CANDIDATES

1. Write your name, class and register number.
2. Do not turn over this page until you are told to do so.
3. Follow all instructions carefully.
4. Answer all questions.
5. Shade your answers on the Optical Answer Sheet (OAS) provided.

**Booklet A (22 x 2 marks)**

For each question from 1 to 22, four options are given. One of them is the correct answer. Make your choice (1, 2, 3 or 4) and shade your answer on the Optical Answer Sheet.

(44 marks)

1. Study the table below.  
Which animal group is matched with the correct body covering?

	<b>Animal Group</b>	<b>Body covering</b>
(1)	bird	moist skin
(2)	reptile	scales
(3)	mammal	feathers
(4)	amphibian	hair

2. The diagram below shows the different parts of a plant.

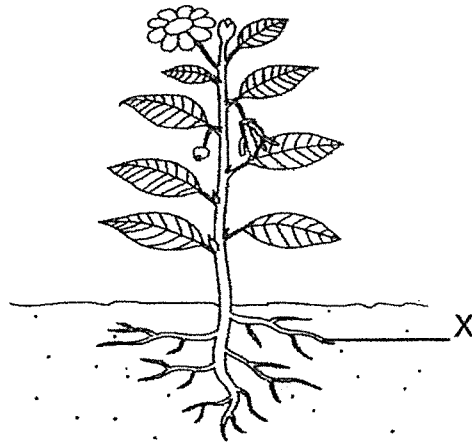

Which of the following are the functions of part X?

- A produces fruits
- B makes food for the plant
- C absorbs water for the plant
- D holds the plant firmly to the soil

- (1) A and C only
- (2) B and C only
- (3) B and D only
- (4) C and D only

3. The diagram below shows the human digestive system and its organs.

Digestion does not take place at one of the organs. Which organ is that?

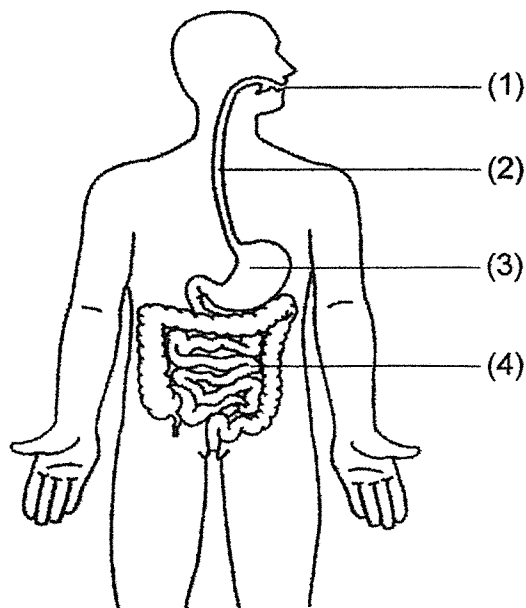

4. The graph below shows the amount of digested and undigested food in the different parts of the digestive system just before it leaves each organ.

Which bar graph correctly represents the large intestine?

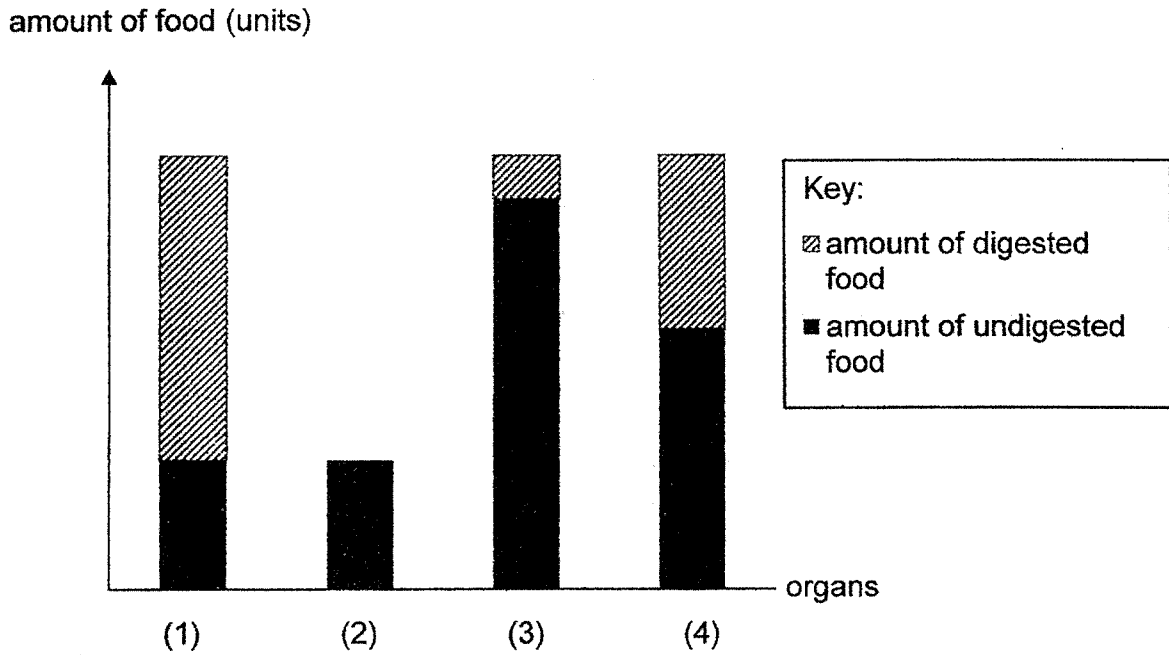

5. The diagram below shows the life cycle of an animal.

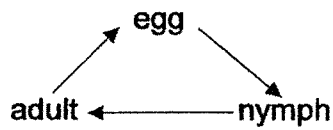

Which animal undergoes the similar life cycle as shown above?

- (1) beetle
- (2) butterfly
- (3) mosquito
- (4) cockroach

6. Siti observed the life cycle of the chicken and the frog. She recorded the number of days taken for some of the stages in the life cycles below.

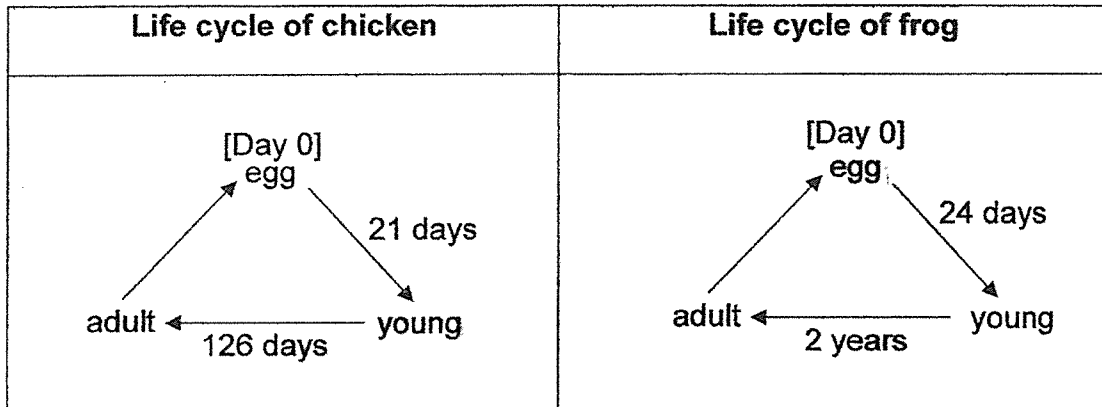

At which stage would each animal be on Day 22?

Life cycle		
	chicken	frog
(1)	egg	young
(2)	young	egg
(3)	young	young
(4)	adult	egg

7. Study the flow chart below.

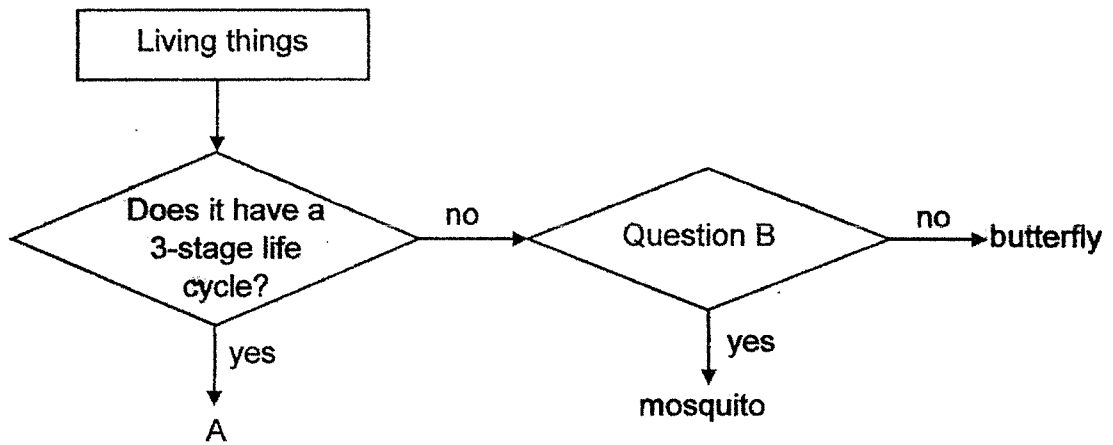

Which of the following represents living thing A and Question B?

	Living thing A	Question B
(1)	beetle	Does the young moult?
(2)	plant	Does the young resemble the adult?
(3)	beetle	Does the young resemble the adult?
(4)	plant	Does it lay eggs in water?

8. Ben released object Q into a basin of water and observed the following as shown in the diagram.

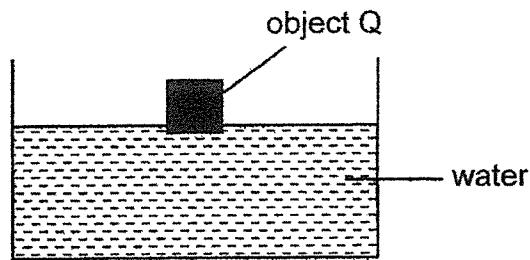

Based on the diagram above, which of the following correctly states the material object Q could be made of and the reason for his observation?

	Material	Reason
(1)	metal	It is strong.
(2)	ceramic	It is waterproof.
(3)	plastic	It is transparent.
(4)	wood	It can float on water.

9. Joshua pours a beaker of water into a basin as shown in the diagram below.

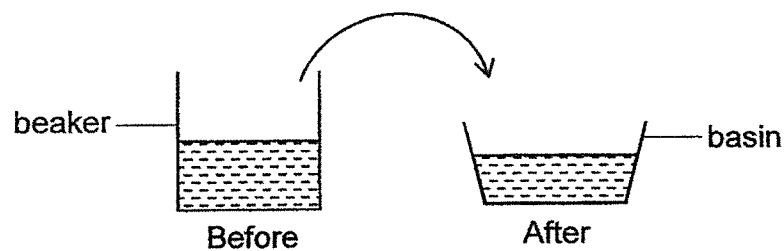

Based on the diagram above, which of the following correctly shows the property of water?

The water \_\_\_\_\_.

- (1) has mass
- (2) can be compressed
- (3) has no definite shape
- (4) has no definite volume

10. Study the classification table below.

Group M	Group N
sound	oxygen
light	cooking oil
shadow	sand

How are the above items classified?

	Group M	Group N
(1)	matter	non-matter
(2)	non-matter	matter
(3)	gas	solid
(4)	solid	liquid

11. Which of the following instruments can be used to measure exactly 35 cm<sup>3</sup> of water?

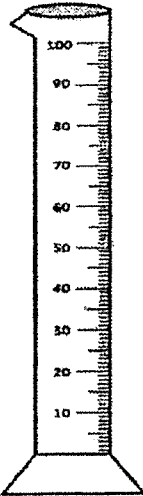
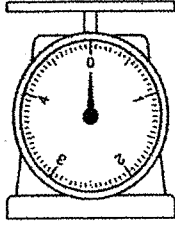
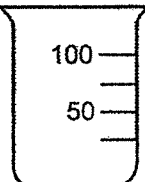
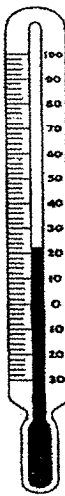
 <p>measuring cylinder</p>	 <p>weighing scale</p>	 <p>beaker</p>	 <p>thermometer</p>
(1)	(2)	(3)	(4)



12. Sam has two identical beakers each containing 200 ml of water. He then places solid objects, Y and Z, into each beaker and the water levels rise as shown in the diagram below.

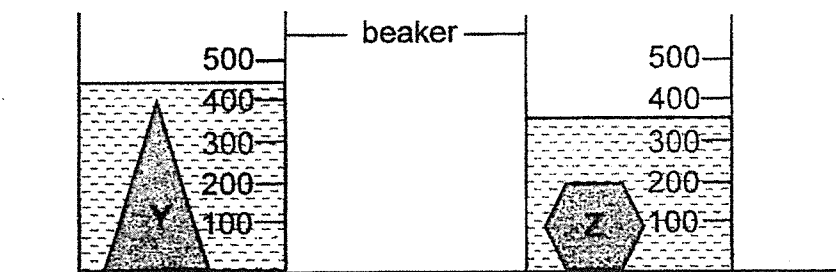

What can Sam conclude from his observation?

- (1) Object Y is heavier than object Z.
  - (2) Object Z has a smaller mass than object Y.
  - (3) Object Z occupies less space than object Y.
  - (4) Object Y has a smaller volume than object Z.
13. Rosa conducted an experiment using the set-up as shown below.

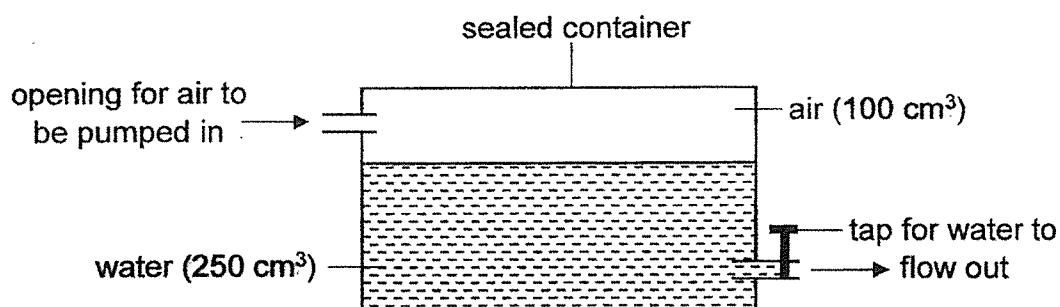

She removed 50 cm<sup>3</sup> of water from the container and pumped in another 100 cm<sup>3</sup> of air. What is the final volume of air in the container?

- (1) 150 cm<sup>3</sup>
- (2) 200 cm<sup>3</sup>
- (3) 250 cm<sup>3</sup>
- (4) 350 cm<sup>3</sup>

14. Four identical empty bottles, A, B, C and D, were pushed into a tank filled with water as shown in the diagram below. Two bottles, C and D, were sealed before being pushed into the water.

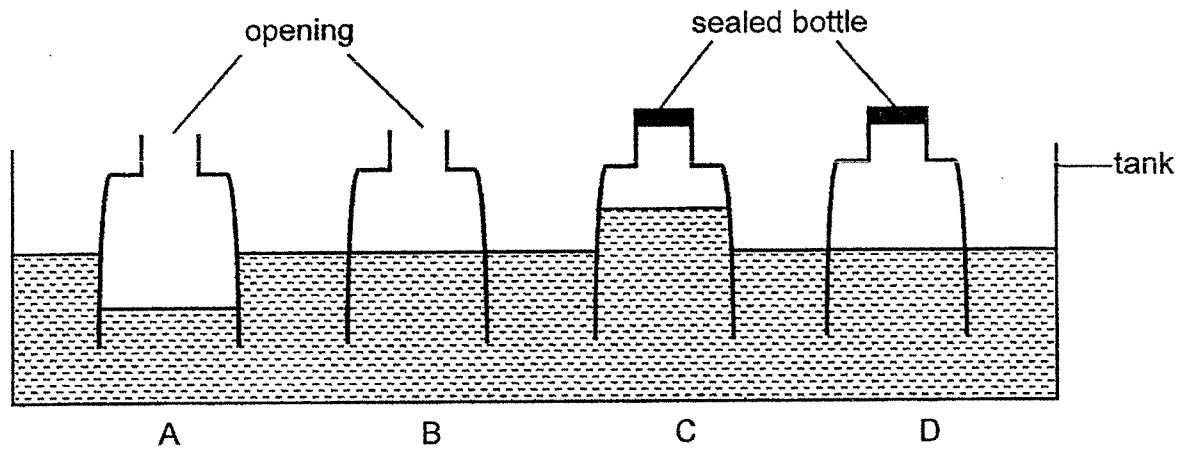

Which bottle shows the correct water level in the bottle?

- (1) A
- (2) B
- (3) C
- (4) D

15. Paul made the following electromagnet to attract some iron nails.

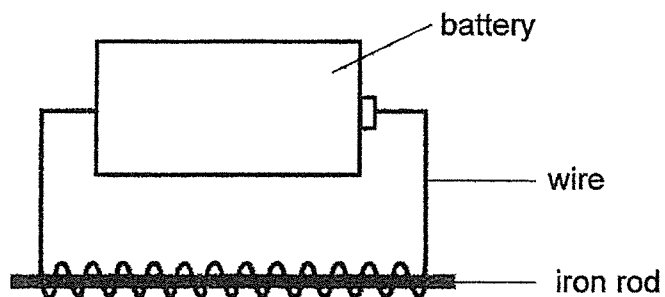

Which of the following method(s) can Paul use to attract more iron nails?

- A use a shorter wire
- B increase the number of batteries
- C change the iron rod to a plastic rod
- D reduce the number of coils of wire around the iron rod

- (1) B only
- (2) A and D only
- (3) B and C only
- (4) C and D only

16. Four magnets are arranged as shown below. A compass is placed near pole H.

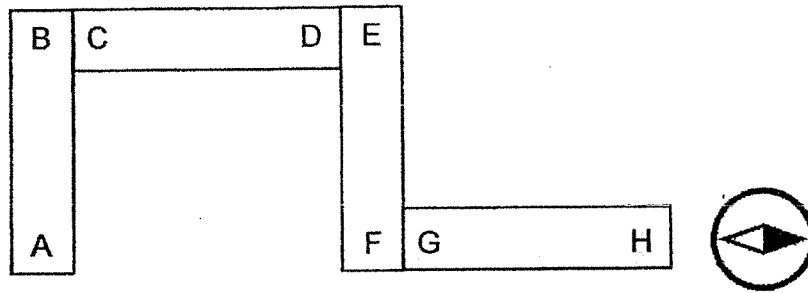

Which of the following shows the correct observation when the ends of two magnets are placed near to each other and a compass is placed at one end?

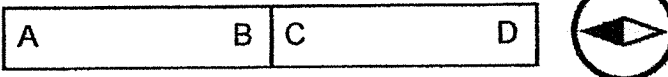
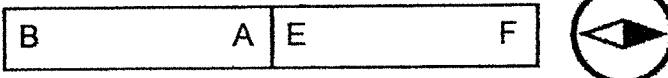
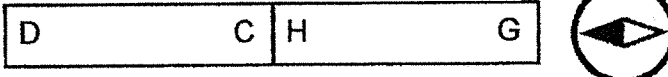
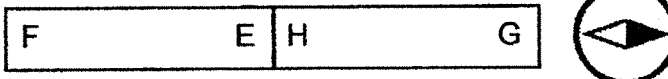
- (1) 
- (2) 
- (3) 
- (4) 

17. Study the diagram below.

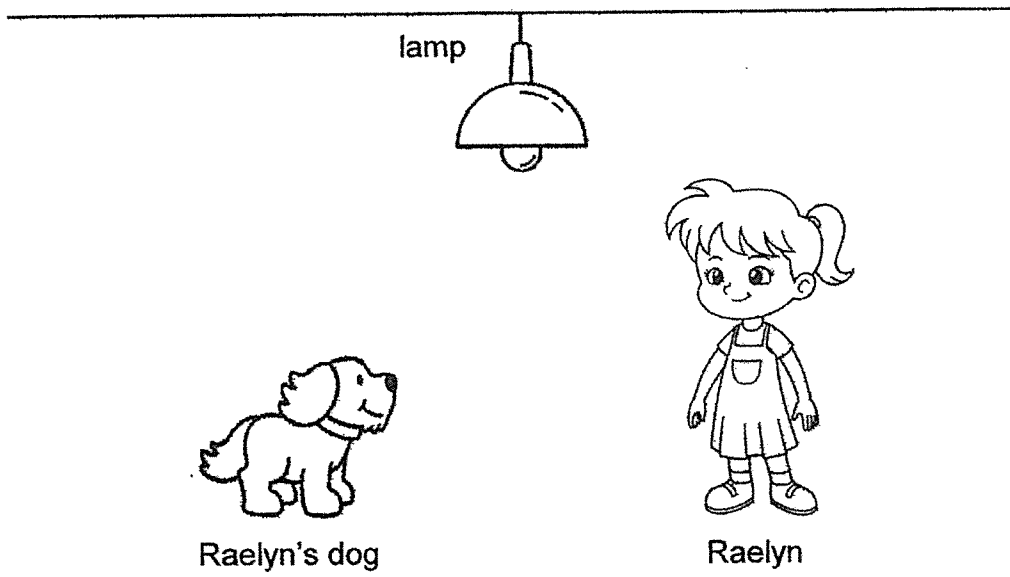

Which of the following shows the path of light that enabled Raelyn to see her dog?

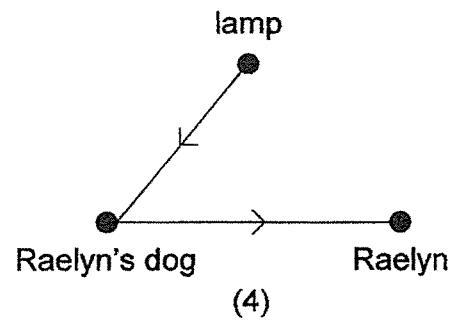
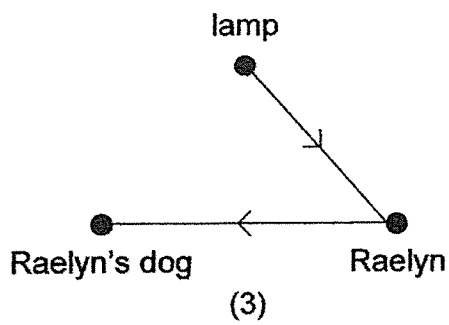
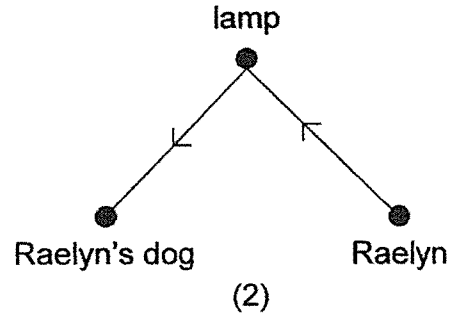
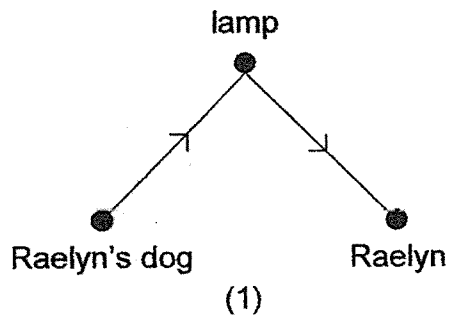

18. The diagram below shows an opaque bottle.

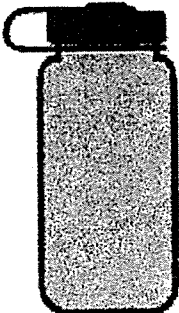

Which of the following shadows cannot be formed by the bottle?

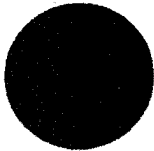

(1)

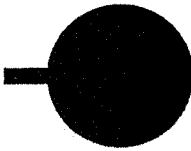

(2)



(3)



(4)

19. With the lamp switched on, Ivan could not see his cat when his cat moved to the other side of the room, which is separated by a wall.

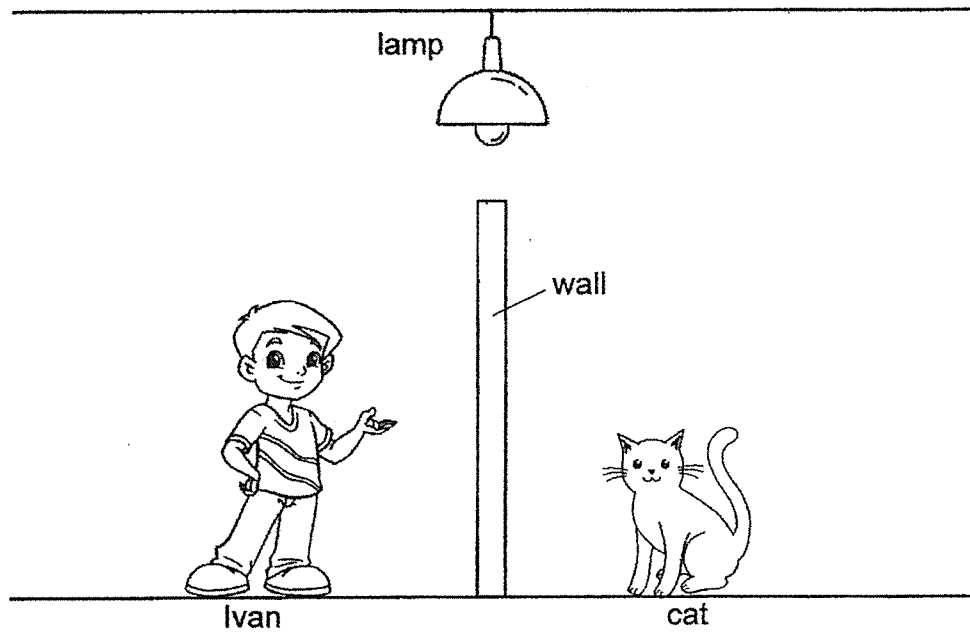

Which of the following explains why Ivan could not see his cat?

- (1) The cat did not reflect light.
- (2) The cat did not give off light.
- (3) The wall did not allow light to pass through.
- (4) The light from the lamp did not enter his eyes.

20. Cheryl sets up an experiment in a dark room as shown below.

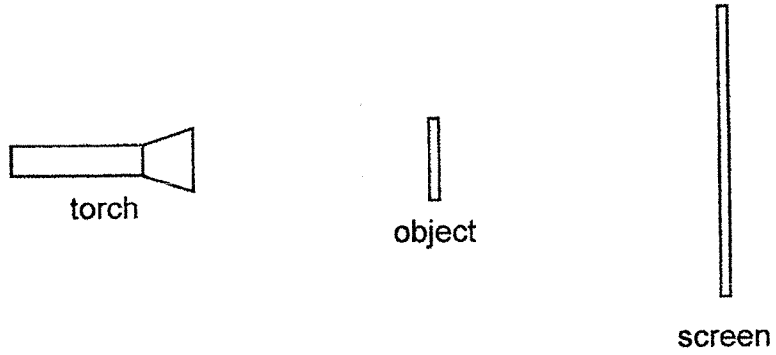

The object is made up of different materials as shown below.

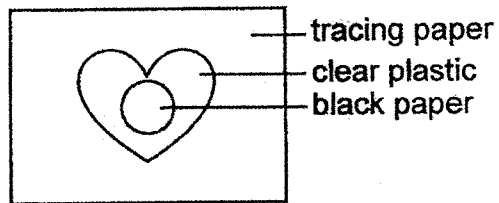

When the torch is switched on, which of the following could be seen on the screen?

Four possible images on a screen, each labeled 'screen' on the right side:

- (1) A white heart shape on a black background.
- (2) A grey heart shape on a white background with a black dot in the center.
- (3) A white heart shape on a grey background with a black dot in the center.
- (4) A black heart shape on a grey background with a white dot in the center.



21. An experiment was conducted to compare the amount of light that passes through four different materials, A, B, C and D.

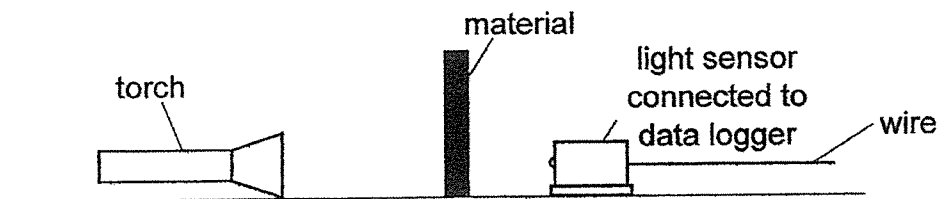

The readings of the light sensor are shown in the bar graph below.

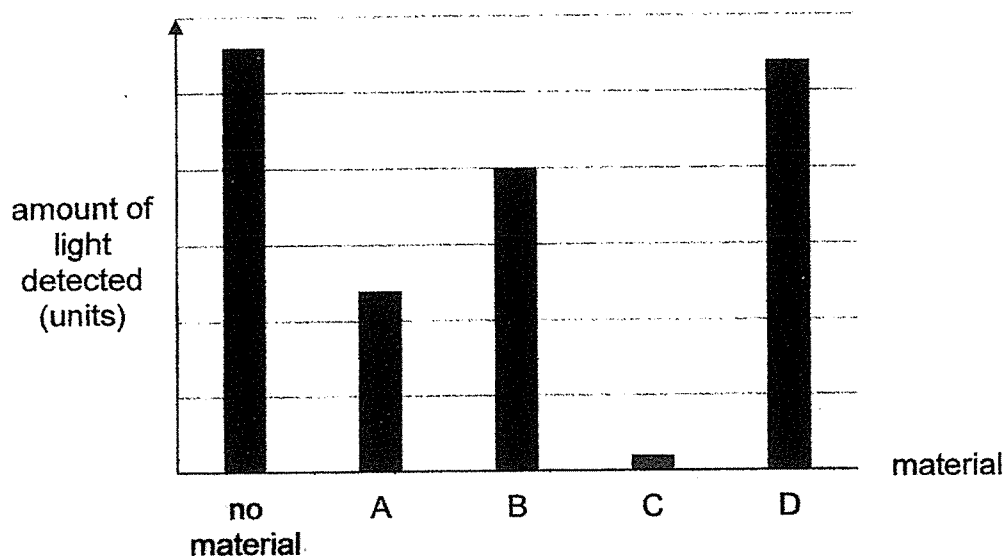

Based on the bar graph above, which of the materials, A, B, C or D, is most suitable to make a fish tank as shown below?

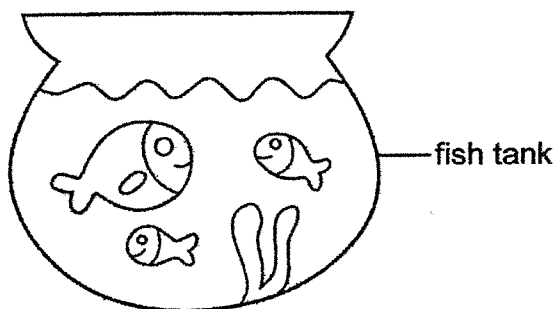

- (1) material A
- (2) material B
- (3) material C
- (4) material D

22. John cut a heart, square and circle with hollow centres out of cardboard, as shown below. The shapes are of equal height.

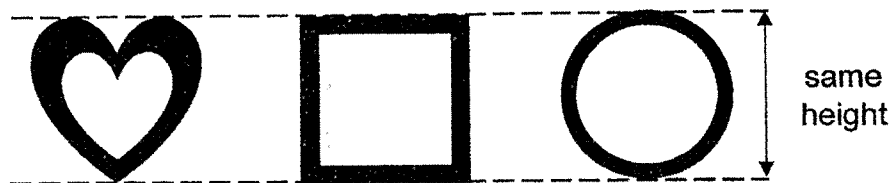

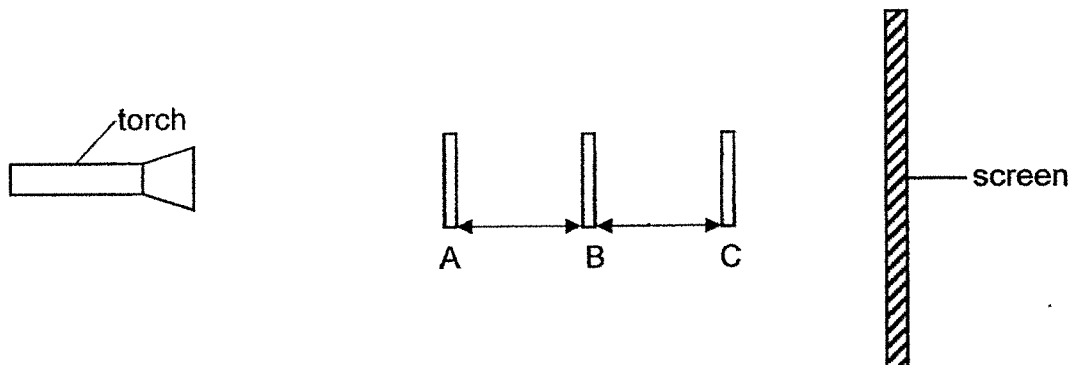

These shapes are placed in front of a torch at positions A, B and C as shown below.

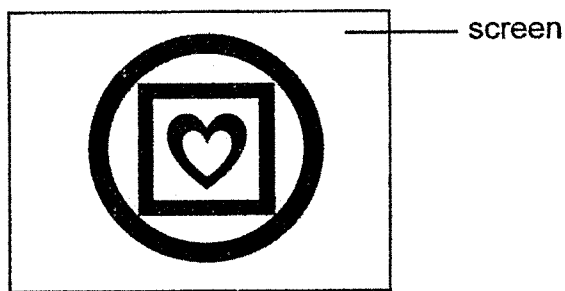

The diagram below shows the shadow that is cast on the screen.

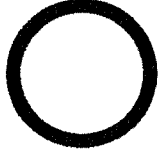

Which of the following best represents where the different shapes were placed at?

			
(1)	A	B	C
(2)	B	A	C
(3)	B	C	A
(4)	C	B	A

End of Booklet A



## 2021 PRIMARY 4 MID-YEAR EXAMINATION

Name : \_\_\_\_\_ ( )

Date: 11 May 2021

Class : Primary 4 ( )

Time: 8.00 a.m. – 9.30 a.m.

Parent's Signature : \_\_\_\_\_

Duration: 1 hour 30 minutes

# SCIENCE

## BOOKLET B

### INSTRUCTIONS TO CANDIDATES

1. Write your name, class and register number.
2. Do not turn over this page until you are told to do so.
3. Follow all instructions carefully.
4. Answer all questions.
5. Write your answers in the booklet.

Booklet A	44
Booklet B	36
Total	80

**Booklet B**

For questions 23 to 34, write your answers clearly in this booklet.

The number of marks available is shown in brackets [ ] at the end of each question or part question. (36 marks)

---

23. The picture below shows animal Y.

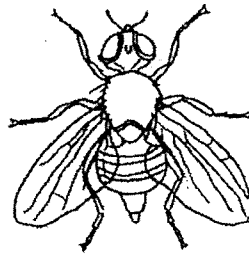

animal Y

(a) Based on the picture above, in which animal group does animal Y belong to? Give a reason for your answer. [2]

---

---

The picture below shows animal Z.

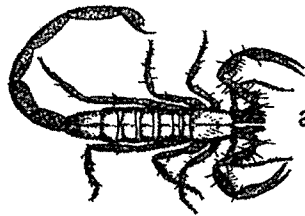

animal Z

(b) Animal Z cannot be classified in the same animal group as animal Y. Give a reason why. [1]

---

---

Score	3
-------	---

24. The following statements describe the different stages as the food moves down the digestive system. Arrange the statements below in the correct order with 1, 2, 3 and 4. [2]

Statement	Order
Digested food is absorbed into the bloodstream.	
Food is cut into pieces and mixed with saliva at the same time.	
Food is passed to another organ that produces more digestive juices.	
Water is absorbed just before undigested food is removed from the body.	

Score	2
-------	---

25. Study the life cycles of animals M and N.

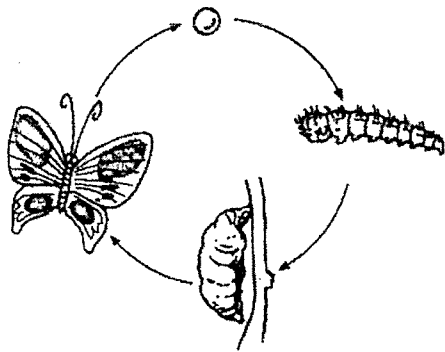

life cycle of animal M

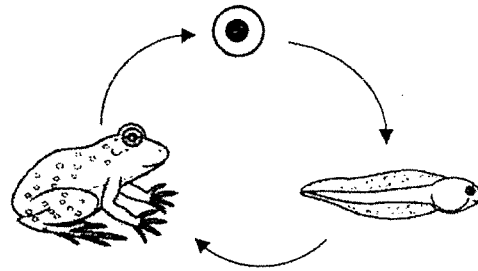

life cycle of animal N

(a) Based on the diagrams above, state two similarities between the life cycles of animals M and N. [2]

Similarity 1: \_\_\_\_\_

\_\_\_\_\_

Similarity 2: \_\_\_\_\_

\_\_\_\_\_

(b) Based on the diagrams above, state one difference between the life cycles of animals M and N. [1]

\_\_\_\_\_

\_\_\_\_\_

Score	3
-------	---

26. The diagram below shows the life cycle of the mealworm beetle.

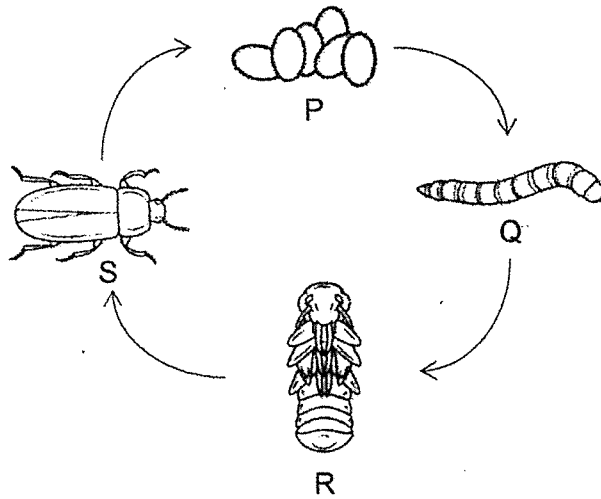

(a) Name the stages, Q and R.

[1]

Q: \_\_\_\_\_

R: \_\_\_\_\_

(b) At which stage(s) of its life cycle does the mealworm beetle not feed on any food?

[1]

\_\_\_\_\_

(c) The female beetle can lay up to 200 eggs at a time. Explain why laying many eggs is important for the beetle.

[1]

\_\_\_\_\_

\_\_\_\_\_

Score	3
-------	---

27. The diagram below shows the growth of a green bean plant but the order is wrong.

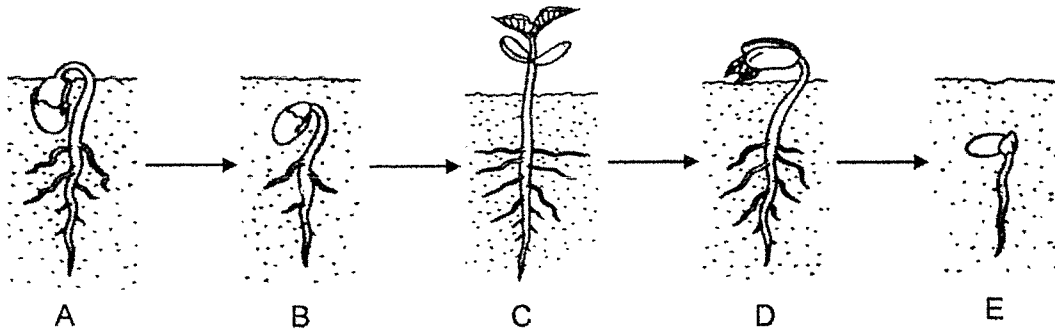

(a) Fill in the boxes below with the letters, A, B, D and E, to show the correct growth order ending with C. [1]



(b) At which stage, A, B, C, D or E, will the green bean plant be able to make its own food? Explain why. [2]

---



---

The picture below shows plant X.

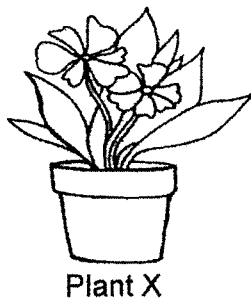

(c) At which stage of its life cycle is plant X in? Explain why. [1]

---



---

Score	4
-------	---



28. Susan placed a piece of kitchen sponge into a container as shown in the diagram below.

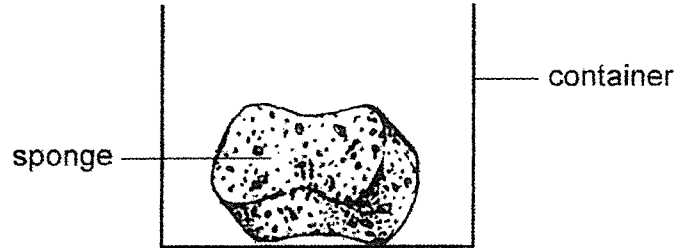

(a) Based on the diagram above, what state of matter is the sponge in? [1]

---

Susan then removed the sponge from the container and squeezed it with her hand.

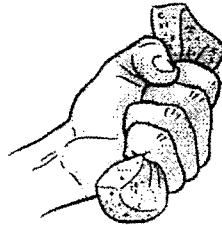

sponge after squeezing

(b) Based on the diagram above, why did the sponge take up less space now? [1]

---

---

Score	2
-------	---

29. Peter has two similar beakers, X and Y. Beaker X contains  $100\text{ cm}^3$  of water and beaker Y is filled with marbles up to the  $100\text{ cm}^3$  mark as shown in the diagram below.

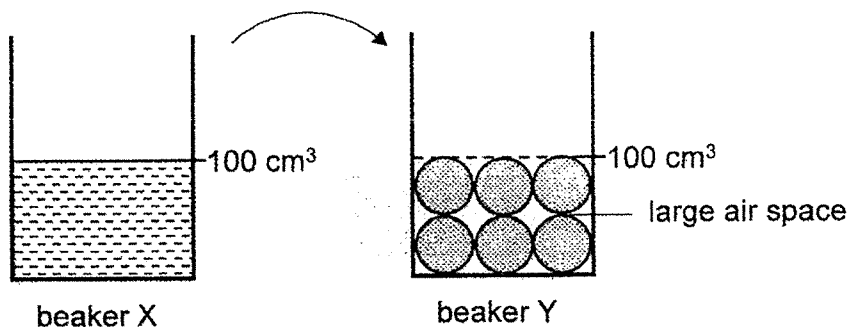

Then, Peter pours all the water from beaker X into beaker Y. The water level in beaker Y reaches the  $160\text{ cm}^3$  mark as shown in the diagram below.

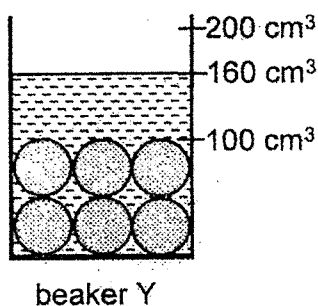

- (a) Explain why the water level rises only to the  $160\text{ cm}^3$  mark and not the  $200\text{ cm}^3$  mark. [1]

---

---

Score	1
-------	---

Peter replaces beaker Y with smaller marbles also up to the 100 cm<sup>3</sup> mark as shown in the diagram below.

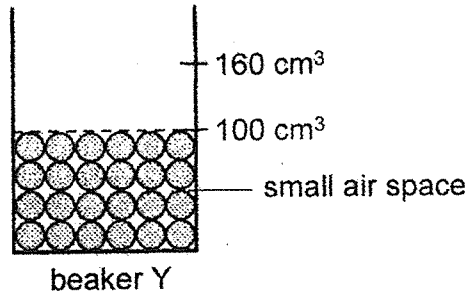

(b) When Peter pours all the water from beaker X into beaker Y again, the water level in beaker Y rises higher than the 160 cm<sup>3</sup> mark. Explain why. [2]

---

---

---

The picture below shows a crow dropping some stones into a pitcher in order to reach the water.

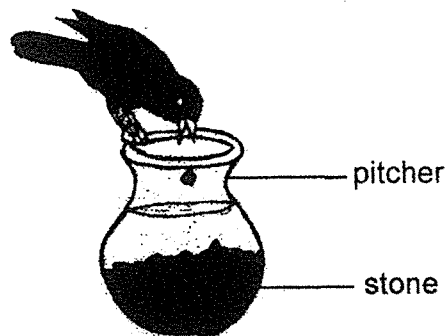

(c) State the property of the stone that enables the water level in the pitcher to rise so that the crow can finally drink the water. [1]

---

---

Score	3
-------	---

30. Joe hung four similar magnets, E, F, G and H, above a tray of iron filings. The diagram below shows the set-up for his experiment.

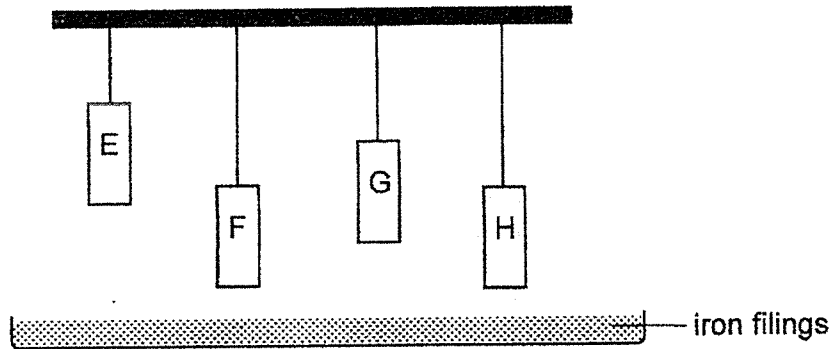

He recorded the amount of iron filings attracted by each magnet in the table below.

Magnet	Mass of iron filings attracted (g)
E	15
F	15
G	10
H	10

- (a) Based on his results, compare the magnetic strength of magnets, G and H. Give a reason for your answer. [2]

---

---

---

Score	2
-------	---

The diagram below shows a magnetic door stopper.

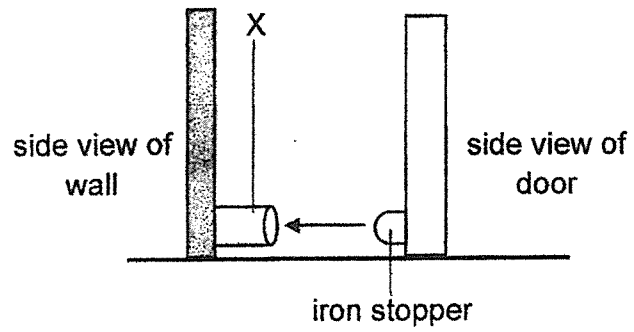

b) Based on the table, which magnet, E, F, G or H, should be used to make X hold the door most tightly on a windy day? Explain why. [2]

---

---

Score	2
-------	---

31. Jessica observed that she could form shadow puppets on the wall using her hands.



(a) Explain how the shadow of the puppet is formed.

[1]

---

---

(b) Jessica walks from point A to C as shown in the diagram below.

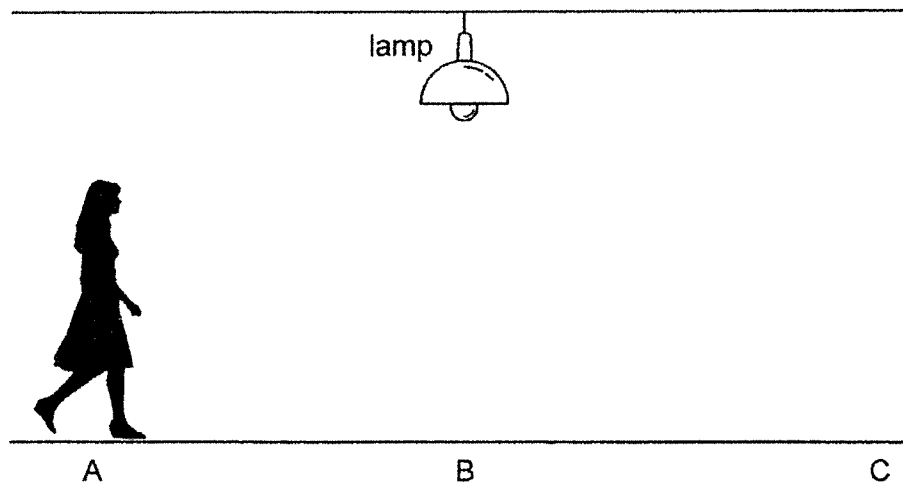

At which point, A, B or C, will her shadow be the shortest? Explain why.

[1]

---

---

Score	2
-------	---

32. Dan placed a wooden block at positions X, Y and Z. He then measured the height of the shadow cast on the screen when the wooden block was at each position.

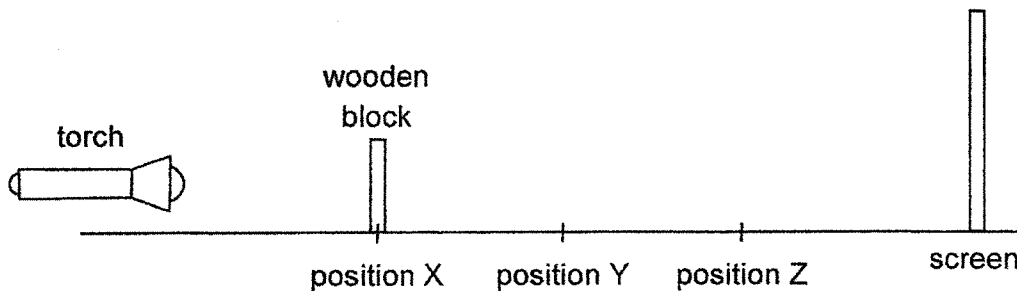

The table below shows his results.

Position of wooden block	Height of shadow (cm)
X	20
Y	16
Z	12

- (a) How does the distance between the wooden block and the torch affect the height of the shadow? [1]

---



---

- (b) Keeping the positions of the wooden block and torch fixed, what can Dan do to obtain a larger shadow? [1]

---



---

Score	2
-------	---

33. Joseph placed three sheets of different materials, P, Q and R in a straight line as shown below. A square was cut out in the centre of material Q and a circle was cut out in the centre of material R. The shapes that were cut out were of the same size.

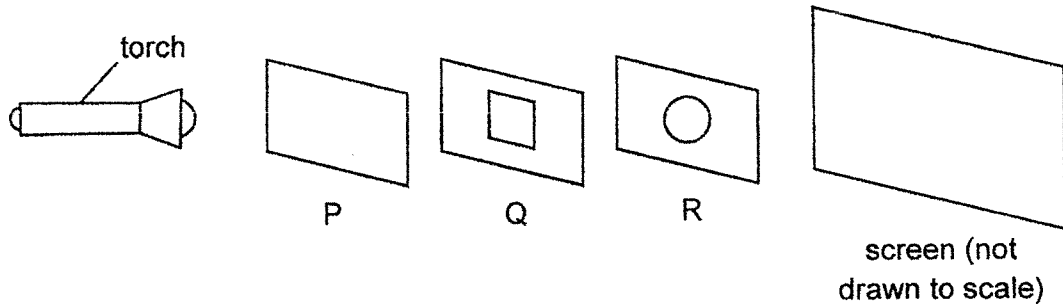

When the torch was switched on, a bright clear circular patch of light with a fainter square inside a dark rectangular shadow was cast on the screen as shown below.

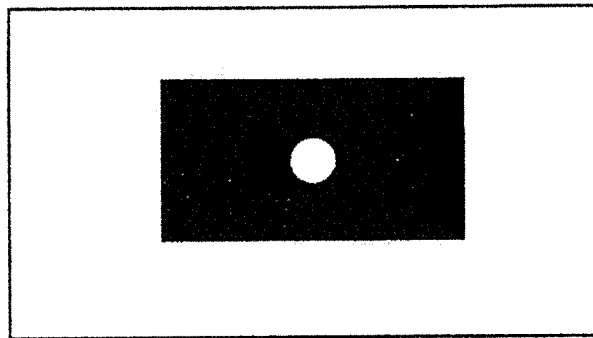

- (a) Fill in the blanks with 'most', 'some' or 'no' to describe the properties of materials, P, Q, R and the screen. [2]

P: allows \_\_\_\_\_ light to pass through.

Q: allows \_\_\_\_\_ light to pass through.

R: allows \_\_\_\_\_ light to pass through.

screen: allows \_\_\_\_\_ light to pass through.

Score	2
-------	---



Joseph wears a pair of sunglasses to protect his eyes on sunny days.

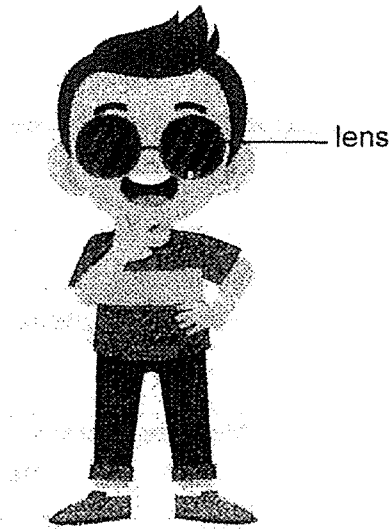

(b) Based on your answer in (a), which of the materials, P, Q or R, is the most suitable for making the lens of the sunglasses? Explain why. [2]

---

---

---

---

Score	2
-------	---

34. Paul set up an experiment as shown in the diagram below.

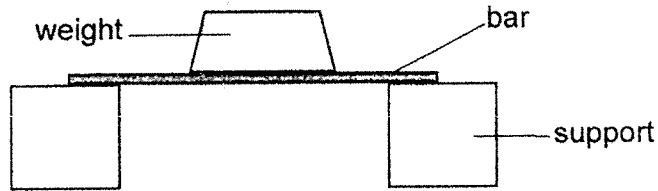

Paul carried out the experiment using 3 bars made of different materials, A, B and C. He recorded the maximum mass each material could withstand before breaking in the table below.

Material	Maximum mass it could withstand before breaking (kg)
A	60
B	20
C	40

(a) What property of material was Paul testing? [1]

---

(b) Paul had a mass of 50 kg. Based on his experiment, which material should he choose to make a chair that he could sit on? Give a reason for your answer. [2]

---

---

---

End of Paper

Score	3
-------	---

## ANSWER KEY

YEAR : 2021  
LEVEL : PRIMARY 4  
SCHOOL : TOA NAN SCHOOL  
SUBJECT : SCIENCE  
TERM : MID-YEAR EXAMINATION

### BOOKLET A

Q1	2	Q2	4	Q3	2	Q4	2	Q5	4
Q6	2	Q7	4	Q8	4	Q9	3	Q10	2
Q11	1	Q12	3	Q13	1	Q14	2	Q15	1
Q16	3	Q17	4	Q18	1	Q19	3	Q20	3

Q21 4      Q22 4

Primary 4 Science Mid-Year Examination (Booklet B)  
Suggested Answers for Students

Qn	Suggested Answer	Check										
23a	Insect Animal Y has 3 body parts/ 6 legs.											
b	Animal Z has 8 legs instead of 6 legs.											
24	<table border="1"> <thead> <tr> <th>Statement</th> <th>Order</th> </tr> </thead> <tbody> <tr> <td>Food is absorbed into the bloodstream.</td> <td>3</td> </tr> <tr> <td>Food is cut into pieces and mixed with saliva at the same time.</td> <td>1</td> </tr> <tr> <td>Food is passed to another organ that produces more digestive juices.</td> <td>2</td> </tr> <tr> <td>Water is absorbed just before remaining food is removed from the body.</td> <td>4</td> </tr> </tbody> </table>	Statement	Order	Food is absorbed into the bloodstream.	3	Food is cut into pieces and mixed with saliva at the same time.	1	Food is passed to another organ that produces more digestive juices.	2	Water is absorbed just before remaining food is removed from the body.	4	
Statement	Order											
Food is absorbed into the bloodstream.	3											
Food is cut into pieces and mixed with saliva at the same time.	1											
Food is passed to another organ that produces more digestive juices.	2											
Water is absorbed just before remaining food is removed from the body.	4											
25a	Both M and N have an egg/ adult stage. Both the young of M and N do not resemble the adult.											
b	Animal M has a 4-stage life cycle while Animal N has a 3-stage life cycle.											
26a	Larva Pupa											
b	Stages P and R											
c	To increase the chances of some eggs hatching/ surviving											
27a	E > B > A > D > C											
b	The leaves are developed so they can trap light to make food.											
c	Adult stage as it has flowers.											
28	Solid.											
b	Air in the sponge was compressed. Air in the sponge escaped.											
29a	The water occupies the spaces previously occupied by the air.											
b	The air spaces between the marbles are smaller. Hence, less water fills up the air spaces between the marbles.											
c	The stones occupy space in the pitcher.											

At stage  
C ←

30a	Magnet G is strongest ✓ Magnet G attracts the same mass from a further distance.					
b	Magnet E is the strongest. It attracted the most iron filings from the furthest distance.					
31a	The light is blocked by her hand.					
b	She is standing directly under the lamp.					
32a	As the distance between wooden block and torch increases, the height of shadow decreases.					
b	He can move the screen further away from the wooden block/torch.					
33a	<table border="1" style="display: inline-table; vertical-align: top;"> <tr> <td>P: most</td> </tr> <tr> <td>Q: no</td> </tr> <tr> <td>R: some</td> </tr> <tr> <td>screen: no</td> </tr> </table>	P: most	Q: no	R: some	screen: no	
P: most						
Q: no						
R: some						
screen: no						
b	R allows some light to pass through. (material Q) He can see and some light blocked/ less light enters his eyes.					
34a	Strength / To test how strong the material is.					
b	A is strongest. It can withstand 60 kg and can carry/ hold Paul without breaking.					

END