



RAFFLES GIRLS' PRIMARY SCHOOL

**MID-YEAR EXAMINATION
2021**

Section A	56
Section B	44
Your score out of 100%	
Parent's signature	

Name : _____ Index No : _____ Class: P4 _____ Date: _____

4 May 2021

SCIENCE

Duration: 1 h 45 min

SECTION A (28 x 2 marks)

For each question from 1 to 28, four options are given. One of them is the correct answer. Make your choice (1, 2, 3 or 4). Shade the correct oval (1, 2, 3 or 4) on the Optical Answer Sheet (OAS) provided.

1. The diagram shows an animal which curled up when Susan touched it.

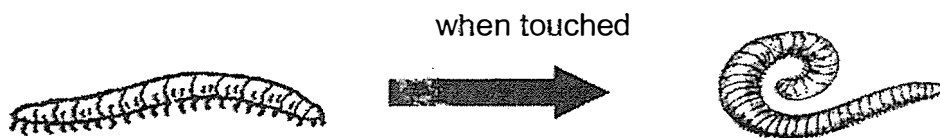

What characteristic of living things does the above diagram show?

- (1) Living things grow.
- (2) Living things reproduce.
- (3) Living things need air, food and water to survive.
- (4) Living things respond to changes in its surroundings.

2. The diagram shows animal A. It is classified as an insect because

_____.

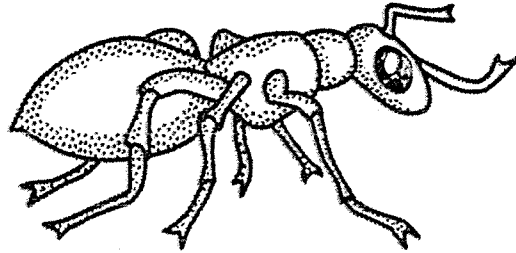

Animal A

- A It has a tail.
- B It has six legs.
- C It has no wings.
- D It has three body parts.

- (1) C only
- (2) B and D only
- (3) A and C only
- (4) A, B and C only

3. The flowchart below shows how some animals are classified.

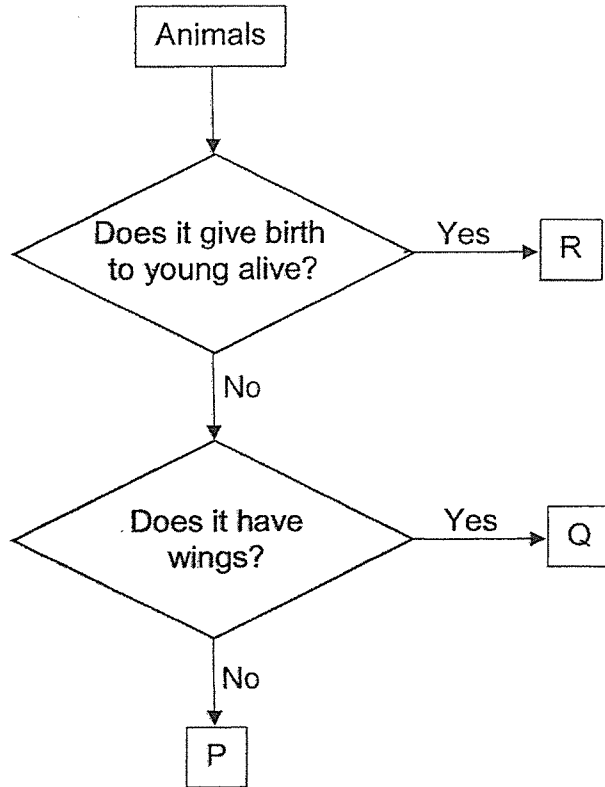

Based on the flow chart above, which one of the following shows the correct identification of animals P, Q and R?

	P	Q	R
(1)	dog	grasshopper	lizard
(2)	lizard	cockroach	cat
(3)	cockroach	shark	grasshopper
(4)	cat	zebra	shark

4. May found some plants in the garden and classified them in the table shown below.

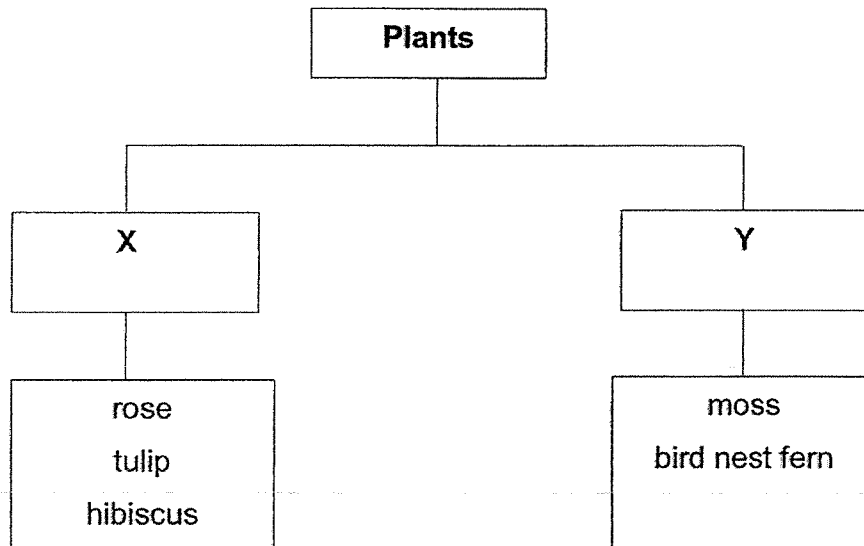

Which one of the following shows the correct headings for X and Y?

	X	Y
(1)	land plants	water plants
(2)	flowering plants	non-flowering plants
(3)	flowering plants	ferns
(4)	water plants	fungi

5. Which of the following statements describe bread mould correctly?

- A It is a type of fungi.
- B It reproduces by spores.
- C It can make its own food.
- D It needs air, food and water to survive.

- (1) A and B only
- (2) C and D only
- (3) A, B and D only
- (4) A, B, C and D

6. The diagrams below show the life cycles of Animal C and Animal D.

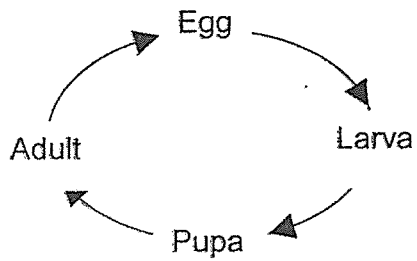

Animal C

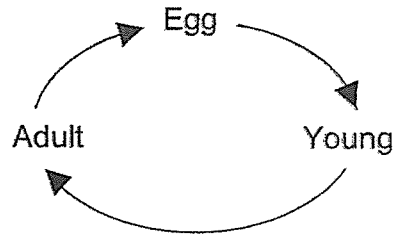

Animal D

Which animals below have a similar life cycle as animals C and D?

	Animal C	Animal D
(1)	hen	mealworm beetle
(2)	cockroach	butterfly
(3)	mosquito	hen
(4)	mealworm beetle	mosquito

7. The table below shows the number of days animals A and B spend in each stage of their life cycles.

Days spent in each stage of its life cycle	Animal A	Animal B
Egg	5	8
Larva	18	30
Pupa	7	12
Adult	22	35

Both animals eat plants in their larval stage.

Based on the information given above, four students come up with the following conclusions about animals A and B.

Roy : Animal A eats more plants than animal B.

Mary : Animal A spends more days as an adult than as a larva.

Sally : Animal B eats more food in its pupal stage than animal A.

Ali : Animal B spends most days as an adult than other stages in its life cycle.

Whose statement(s) is/are correct?

- (1) Ali only
- (2) Sally and Roy only
- (3) Ali and Mary only
- (4) Ali, Mary and Sally only

8. The following statements show the different stages in the life cycle of a plant.

- A The shoot grows upwards.
- B The root grows downwards.
- C The seedling develops its first leaves.
- D The young plant uses sunlight to make food.

Which one of the following shows the correct stages of growth?

- (1) A → C → B → D
- (2) A → B → C → D
- (3) B → A → C → D
- (4) B → C → A → D

9. The diagrams below show four set-ups, R, S, T and U. One seed is placed on each petri dish.

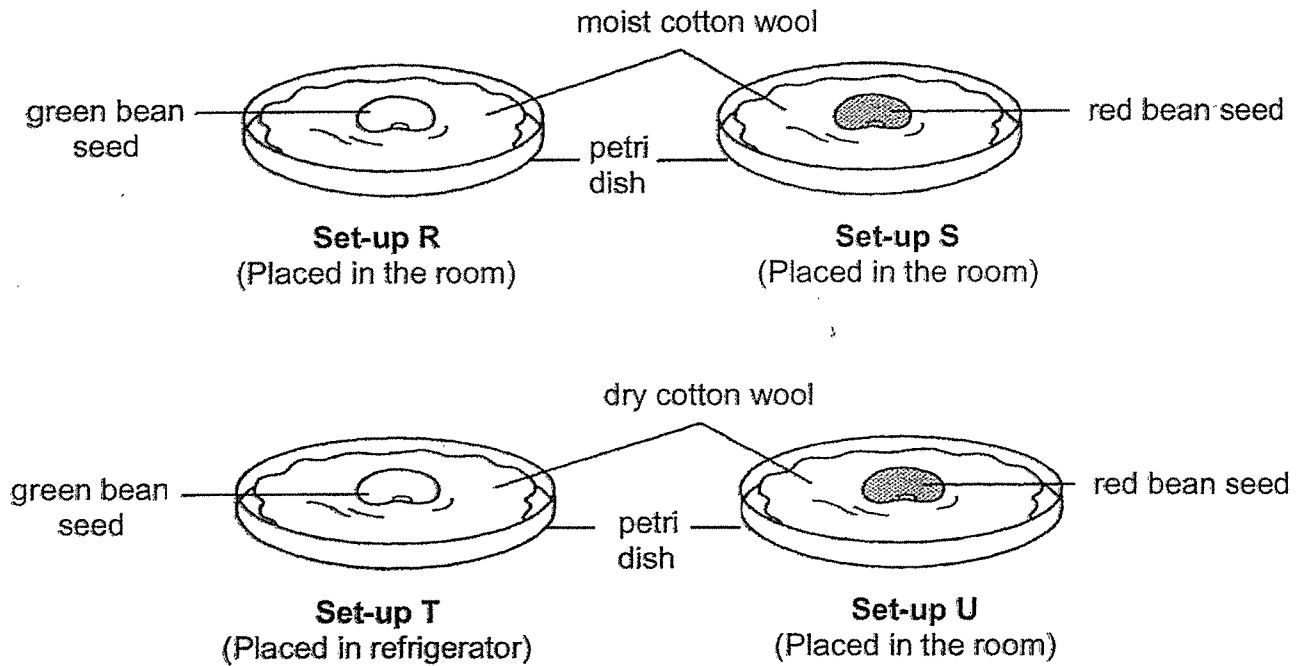

Steven wants to investigate if water is needed for germination. Which of the two set-ups should he use?

- (1) R and S only
- (2) S and U only
- (3) R and T only
- (4) T and U only

10. Study the diagram below.

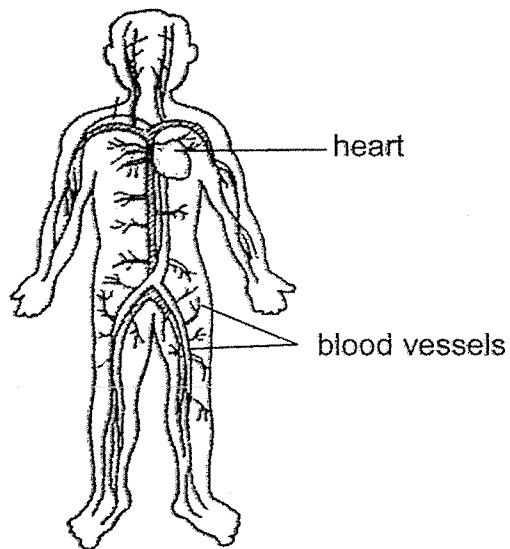

Which organ system does it belong to?

- (1) skeletal
- (2) digestive
- (3) circulatory
- (4) respiratory

11. Which two systems work together to enable our bodies to move?

- A skeletal
- B circulatory
- C muscular
- D respiratory

- (1) A and B
- (2) A and C
- (3) B and C
- (4) B and D

12. Study the flowchart below.

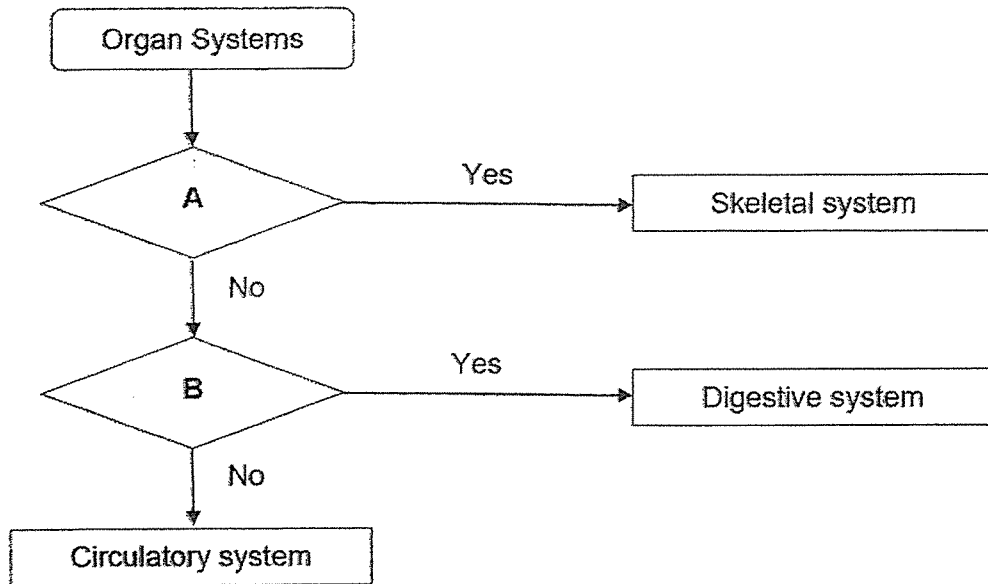

Which of the following represent **A** and **B**?

	A	B
(1)	Protects the organs in the body	Breaks down food into simpler substances
(2)	Transports digested food to all parts of the body	Supports the body
(3)	Takes in air into the body	Enable different parts of the body to move
(4)	Breaks down food into simpler substances	Gives the body shape

13. The chart below shows the amount of digested food in various organs in the human digestive system at the end of the digestion process.

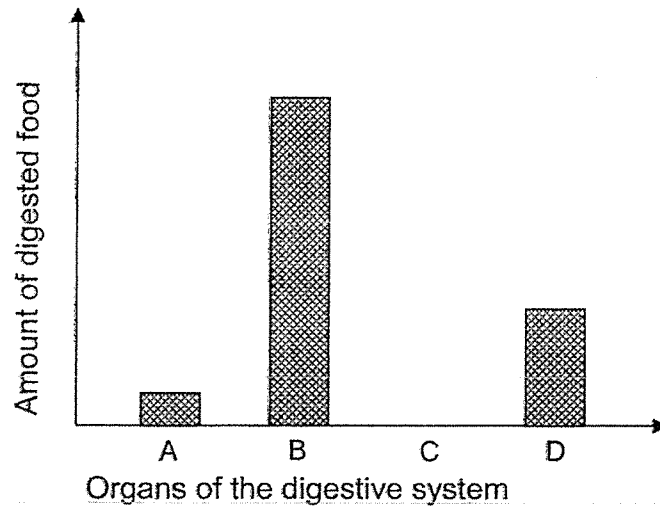

Based on the graph above, which one of the following best represents A, B, C and D respectively?

	A	B	C	D
(1)	mouth	large intestine	stomach	small intestine
(2)	mouth	small intestine	large intestine	stomach
(3)	stomach	mouth	large intestine	small intestine
(4)	large intestine	small intestine	stomach	mouth

14. The diagram below shows a young plant.

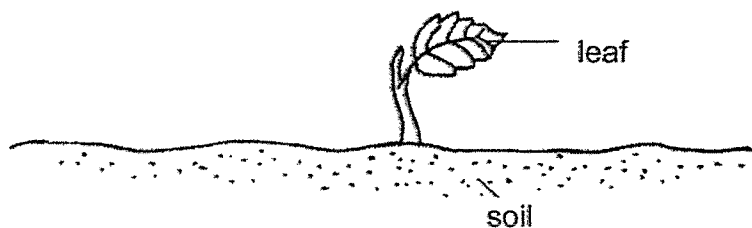

The leaf helps the plant to _____.

- (1) make food
- (2) grow upright
- (3) absorb water
- (4) absorb nutrients

15. Which of the following are the functions of the stem of a plant?
- A Holds the plant upright
 - B Takes in water from the soil.
 - C Takes in mineral salts from the soil
 - D Transports food from the leaves to the other parts of the plant
- (1) A and D only
 (2) B and C only
 (3) A, B and C only
 (4) A, C and D only

16. Andy made two cuts in the stem of a plant as shown below.

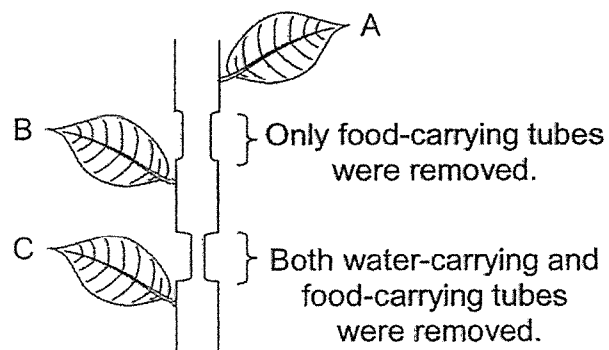

After the cuts were made on the stem, which of the leaves is/are still able to make food after some time?

- (1) A only
 (2) C only
 (3) A and B only
 (4) B and C only

17. Ryan carried out an investigation. He placed two similar plants in the set-ups as shown below. The plant in set-up A had roots while the plant in set-up B had its roots removed.

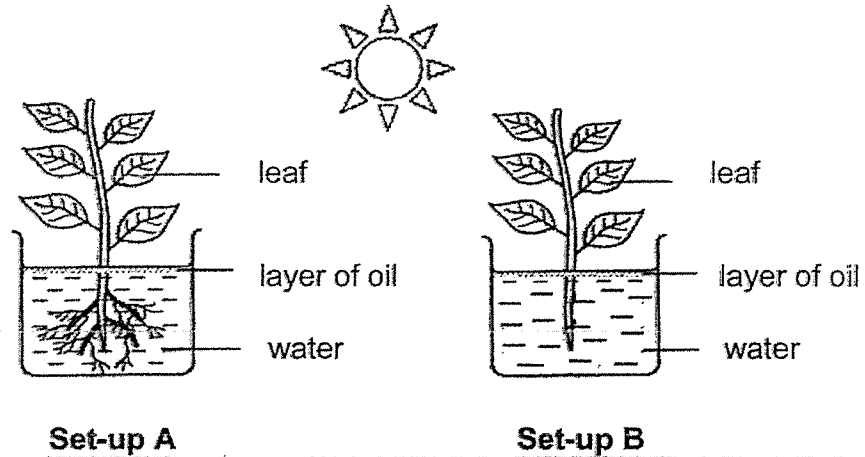

In his investigation, Ryan wanted to find out if _____.

- (1) oil will affect the growth of plants
 - (2) plants need roots to take in water
 - (3) water is needed for plants to make food
 - (4) sunlight is needed for plants to make food
18. Some objects are grouped in the classification table below.

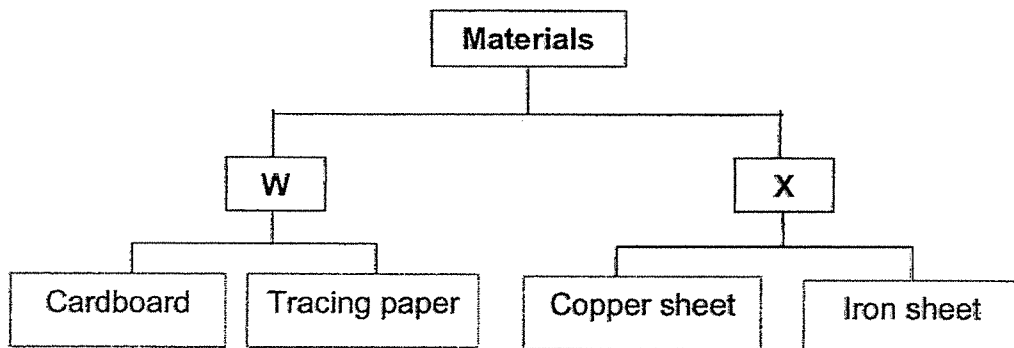

Which of the following properties represent W and X?

	W	X
(1)	Not waterproof	Waterproof
(2)	Non-flexible	Flexible
(3)	Sink	Float
(4)	Does not allow light pass through	Allow light pass through

19. Danny wanted to find out which material is most suitable to block out sound. He set up an experiment as shown below.

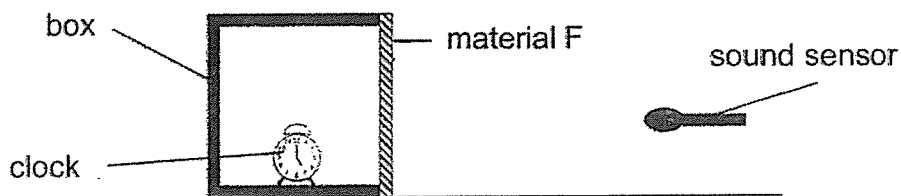

Danny covered one side of the box using material F.

The clock was set to ring at a fixed volume. Danny recorded the loudness of the sound from the clock with a sound sensor. He repeated the experiment using materials G, H and I, of the same thickness as F one at a time.

The table below shows the results.

Material	Loudness of sound detected by sound sensor (unit)
F	80
G	30
H	50
I	60

Danny wanted to choose a material to block out sound from his music room most effectively.

Which material, F, G, H or I, should he use for the walls of the music room?

- (1) F
- (2) G
- (3) H
- (4) I

20. Which one of the following properties is true for both air and a pencil?

- (1) They can be seen.
- (2) They take up space.
- (3) They have fixed shapes.
- (4) They have fixed volumes.

21. David poured 250 ml of water into each of the three measuring cylinders. Then he placed three different objects, R, S and T, into the cylinders as shown in the diagram below.

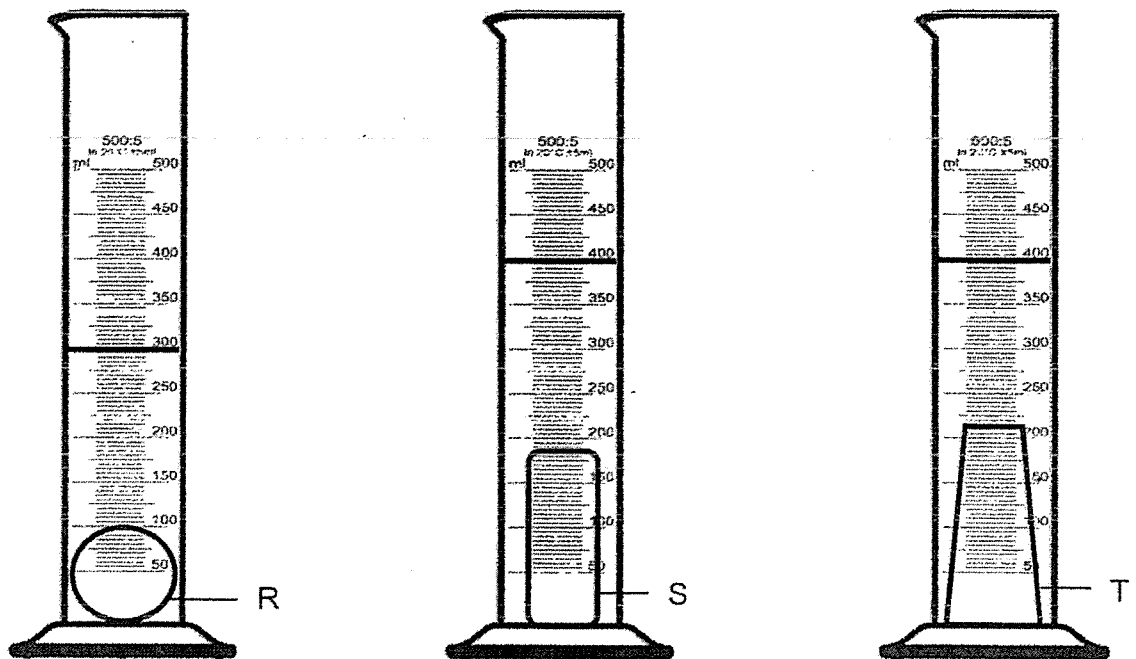

Based on his observations, which of the following conclusions are correct?

- A Object T has a greater volume than Object R.
- B Object S has a greater volume than Object R.
- C Objects S and T have the same volume.

- (1) A and B only
- (2) A and C only
- (3) B and C only
- (4) A, B and C

22. Study the flow chart below.

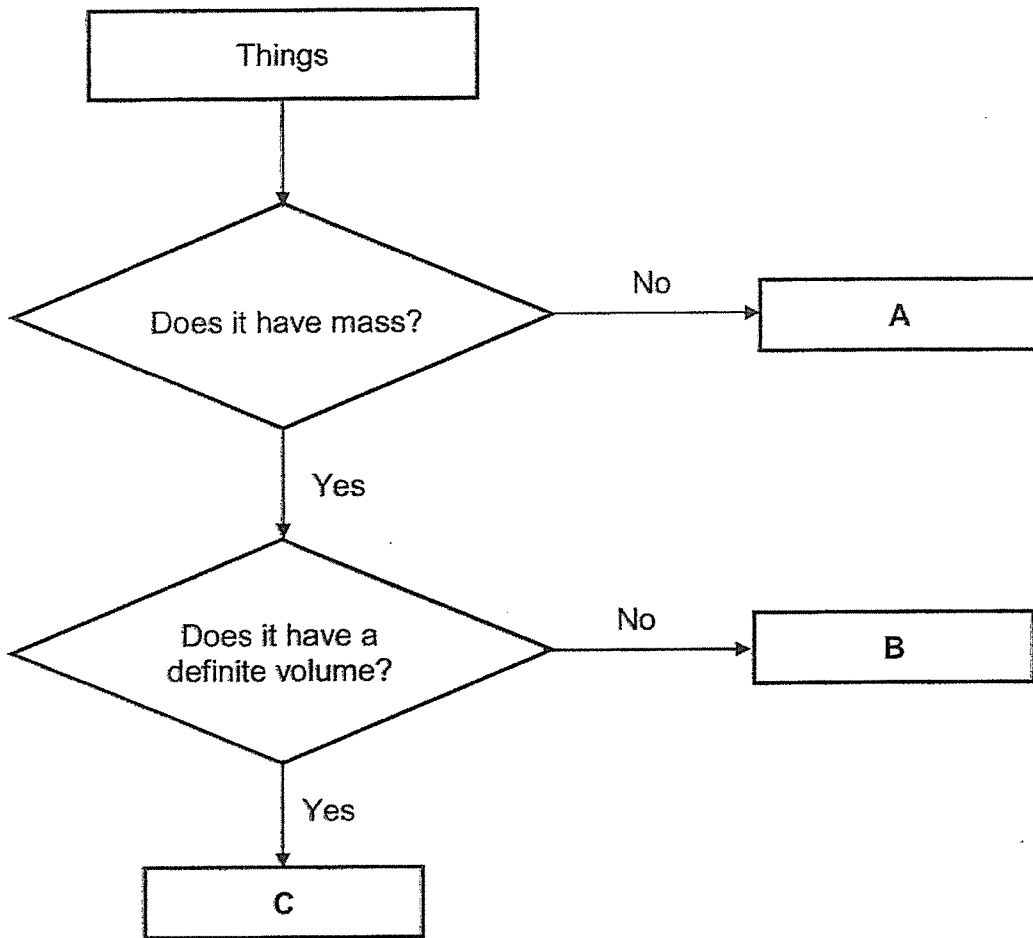

Which one of the following best represents A, B and C?

	A	B	C
(1)	Sound	Water	Air
(2)	Water	Stone	Oil
(3)	Shadow	Oxygen	Oil
(4)	Air	Stone	Oxygen

23. Andy filled two similar syringes, X and Y, with the same volume of water and air as shown below. He covered each syringe with one finger.

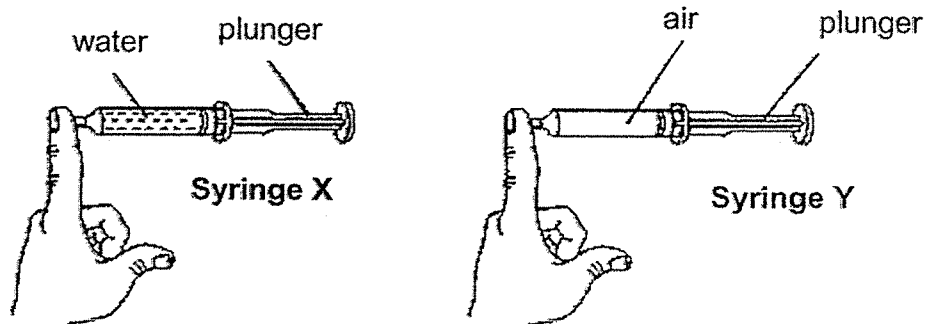

When he pushed in the plunger of each syringe, he observed that the plunger of syringe X could not move while the plunger of syringe Y could move in a little.

Based on his observations, which of the following conclusions could Andy make?

- A Air cannot be compressed.
- B Water cannot be compressed.
- C Air has no fixed volume.
- D Water has no fixed volume.

- (1) A and B only
- (2) A and D only
- (3) B and C only
- (4) C and D only

24. The diagrams below show three containers, A, B and C, of different capacities. An air pump was connected to each container.

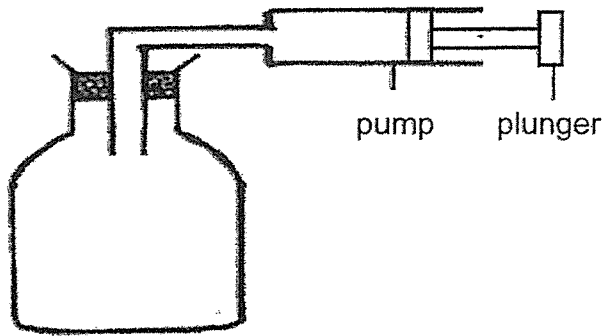

Container A
(Capacity: 1500 cm³)

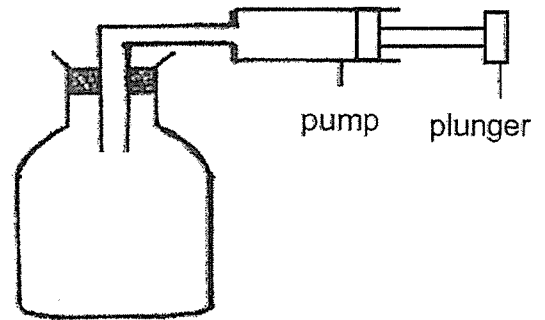

Container B
(Capacity: 1000 cm³)

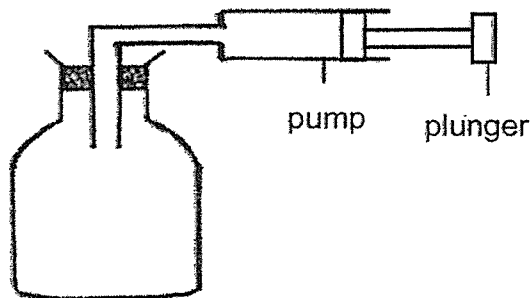

Container C
(Capacity: 700 cm³)

Which of the following shows the final volume of air in each container after 200 cm³ of air was pumped into each container?

	Volume of air (cm ³)		
	A	B	C
(1)	1700	1200	900
(2)	1600	1300	1000
(3)	1500	1200	900
(4)	1500	1000	700

25. The diagram below shows the maximum number of paper clips magnets J, K, L and M attracted at their respective heights.

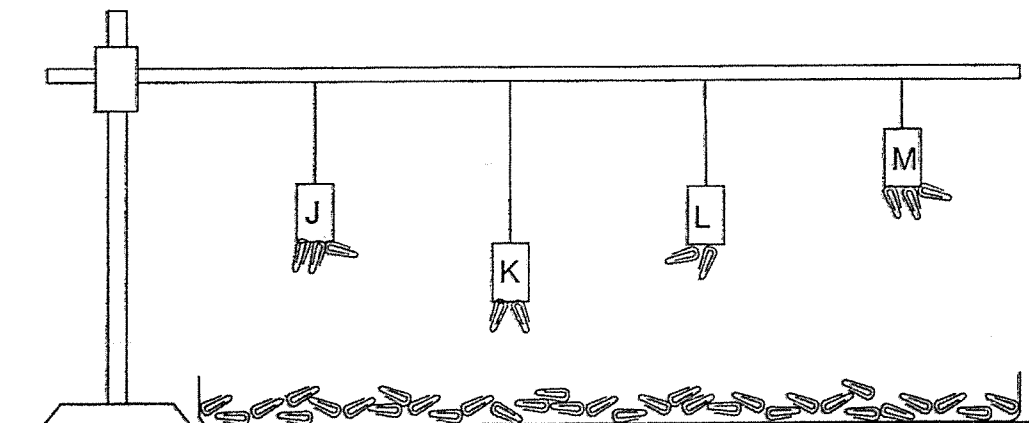

Which of the following shows the strength of the magnets, arranged from the strongest to the weakest?

	Strongest	→	Weakest
(1)	J	K	L
(2)	K	L	J
(3)	M	L	J
(4)	M	J	L

26. Siti labelled the different parts of an iron rod, P, Q and R. She stroked the iron rod thirty times with a magnet in the direction as shown below.

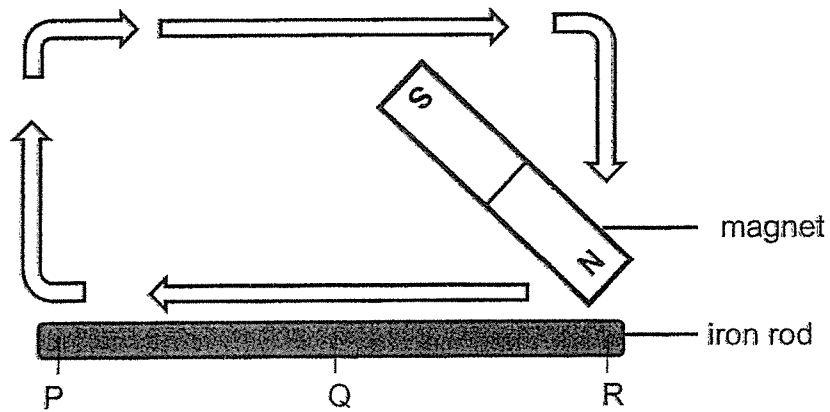

Siti observed that the iron rod was able to attract some steel paper clips.

Which of the following is/are true about the iron rod after it has been stroked by the magnet?

- A Part P of the iron rod was the North pole.
 - B Only part R of the iron rod was able to attract steel paper clips.
 - C Part R of the iron rod was able to attract more steel paper clips than part Q.
- (1) A only
(2) C only
(3) A and B only
(4) B and C only

27. Three magnets are arranged as shown below.

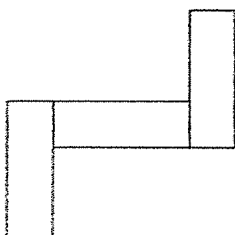

Which one of the diagrams below shows the correct poles of the magnets?

(1)

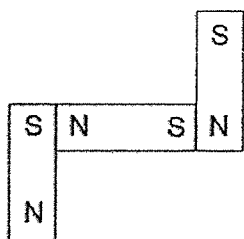

(2)

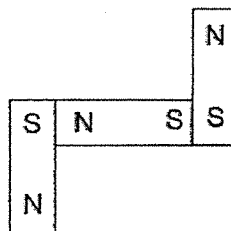

(3)

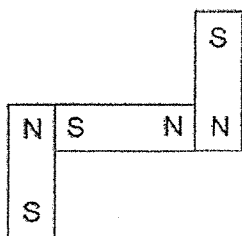

(4)

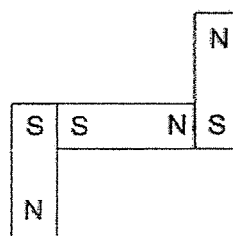

28. A piece of note was left on the door of the refrigerator. The note was held onto the door with the help of a magnet as shown below.

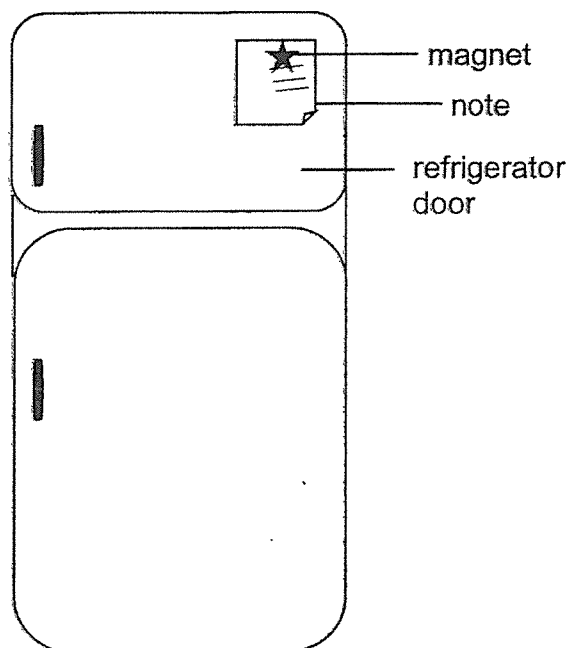

Which of the following shows the correct properties of the note, refrigerator door and magnet that allowed the note to be held onto the door of the refrigerator by the magnet?

	Property of the note	Property of the refrigerator door	Property of the magnet
(1)	magnetic material	magnetic material	magnetic material
(2)	magnetic material	non-magnetic material	non-magnetic material
(3)	non-magnetic material	magnetic material	non-magnetic material
(4)	non-magnetic material	magnetic material	magnetic material

Name : _____ Index No: _____ Class: P4 _____

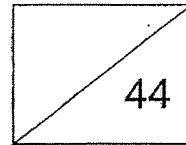

SECTION B (44 marks)

For questions 29 to 41, write your answers clearly in the spaces provided. The number of marks available is shown in brackets [] at the end of each question or part question.

29. Steven carried out an experiment to find out the conditions needed by snails to survive. He kept three snails in each container as shown below.

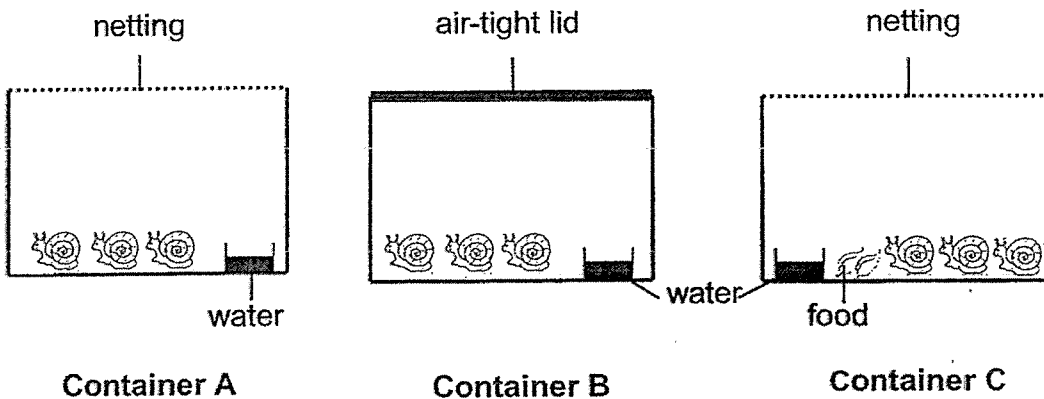

(a) In which container would the snails survive the longest? Give a reason for your answer. [1]

(b) Steven commented that the snails in container B would be able to survive longer than the snails in container A. Do you agree with him? Give a reason for your answer. [1]

(c) Steven set up another container D that has the same condition as container C, except that he only put in 1 snail.
Would the snail in container D survive longer than the snails in container C?
Give a reason for your answer. [1]

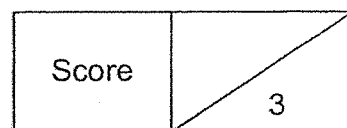

30. A classification chart below shows how animals W, X, Y and Z are being grouped.

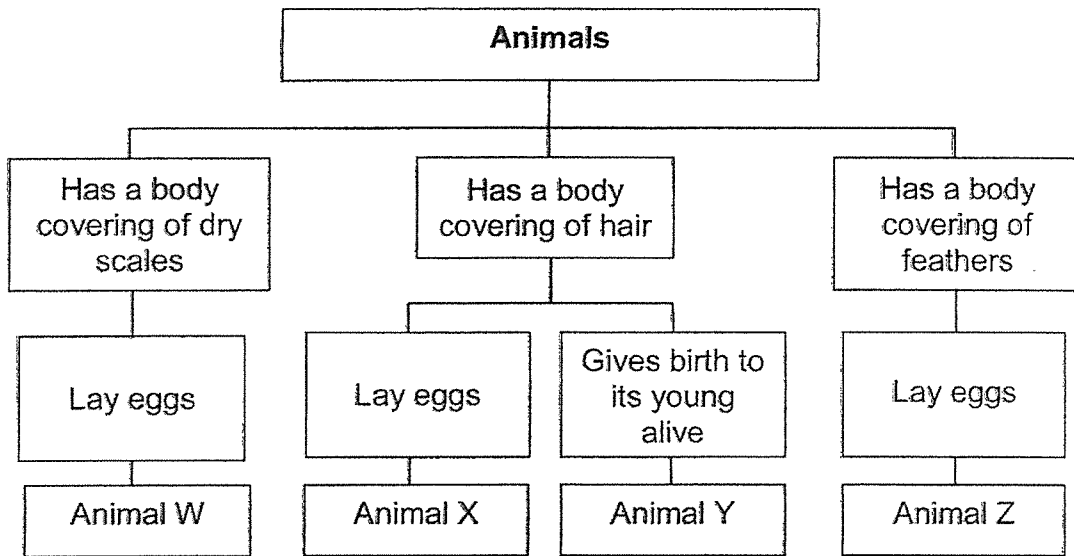

(a) Based on the classification chart above, name the group of animals that animal W belongs to. [1]

(b) Based on the information above, list two characteristics of animal Y. [1]

(c) Study the animal below carefully.

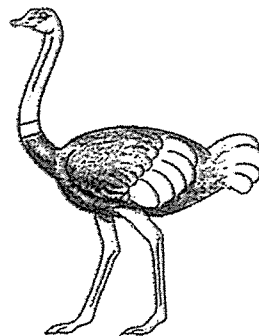

Which animal, W, X, Y or Z, represents the animal above? [1]

Animal _____.

Score	3
-------	---

31. The diagram below shows the life-cycles of a grasshopper and a butterfly.

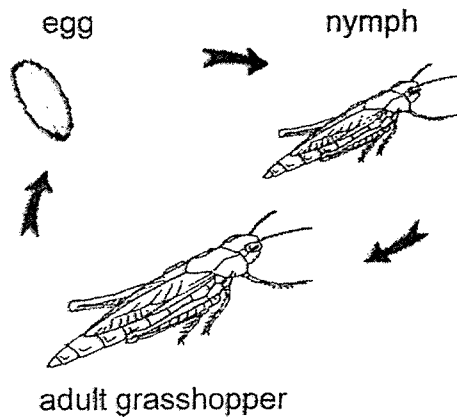

Life-Cycle of Grasshopper

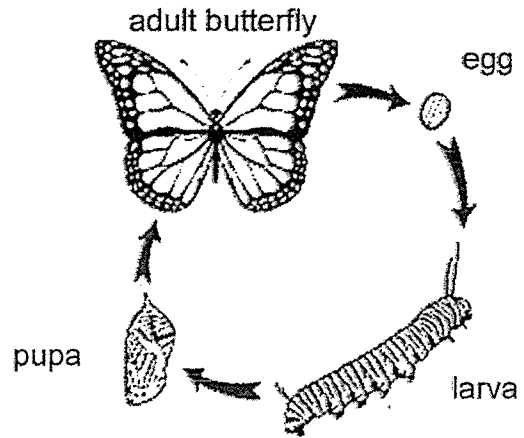

Life-Cycle of Butterfly

(a) Based on the diagrams above, state two differences between the two life-cycles.

[2]

Difference 1:

Difference 2:

(b) The grasshoppers often destroy the plants that farmers grow.

At which stage would it be easiest for the farmer to get rid of the grasshoppers?
Explain your answer.

[1]

Score	3
-------	---

32. The diagrams below show the different stages of development of a plant.

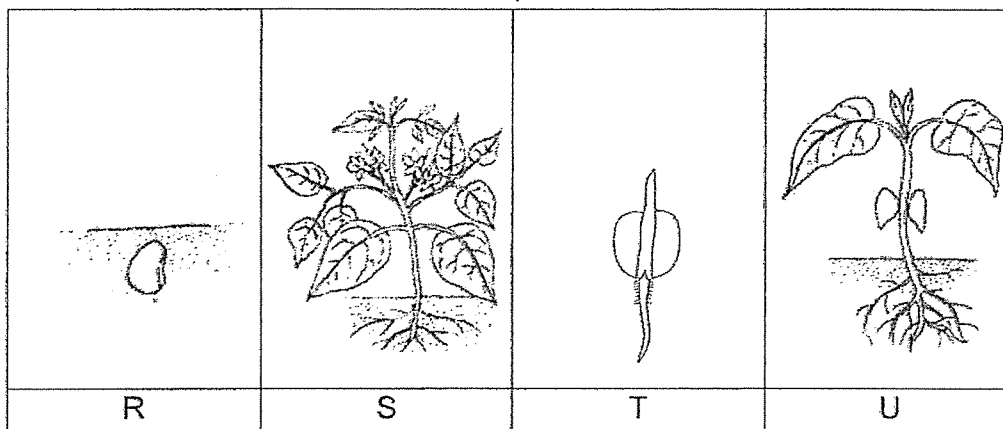

(a) Complete the diagram below with the letters, R, S and U, to show the correct order of the developmental stage. [1]

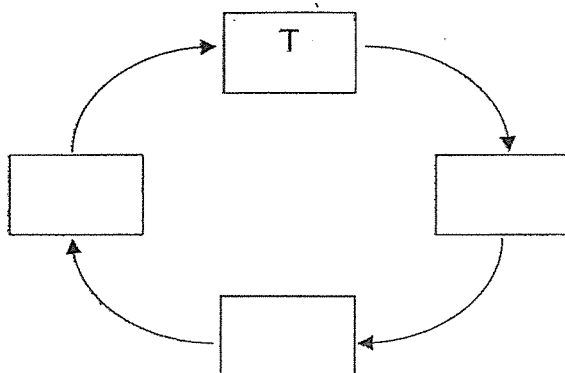

(b) At which stage(s), R, S, T or U, can the plant make food on its own?

Give a reason for your answer.

[2]

(c) What will happen to the seed leaves when the plant grows into an adult plant? [1]

Score	4
-------	---

33. The diagram below shows the human digestive system.

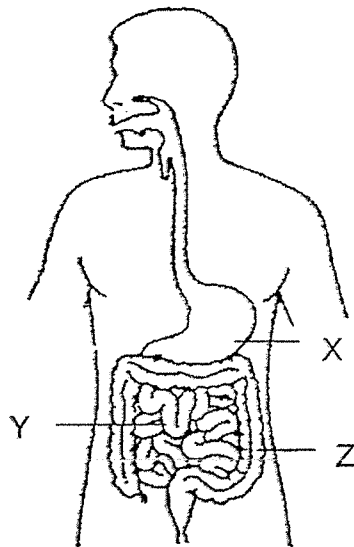

(a) Name parts X and Y. [2]

(i) X: _____

(ii) Y: _____

(b) Which of the following takes place at part Z? [1]

Tick (✓) the correct answer.

Food is digested.

Food is mixed with saliva.

Water is removed from undigested food.

Score	3
-------	---

34. The diagram below shows how oxygen and carbon dioxide are transported in the human body.

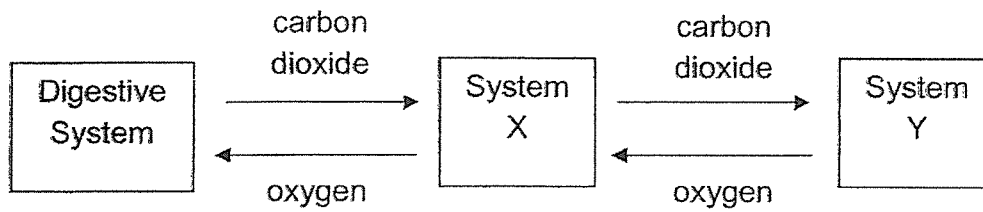

- (a) Name systems X and Y. [1]

X: _____

Y: _____

Study the diagram below.

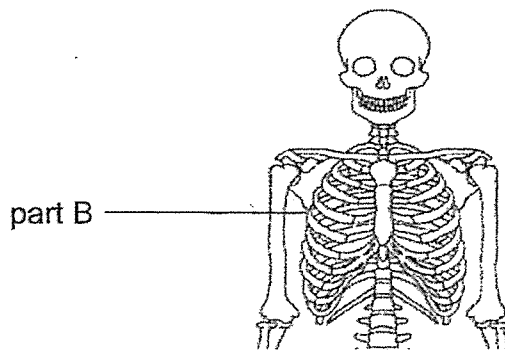

- (b) Which body system does part B belong to? [1]

- (c) State one function of part B. [1]

Score	3
-------	---

35. Two different plants, W and Z, are shown in the diagrams below.

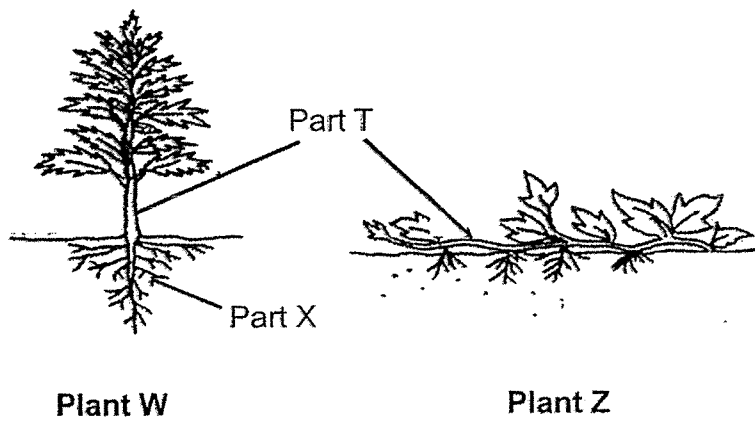

(a) Name part T. [1]

(b) Name one function of part T. [1]

(c) State one difference on the characteristic of part T between both plants. [1]

(d) Part X grows over a wide area and deep into the ground. Give one advantage for the plant. [1]

Score	4
-------	---



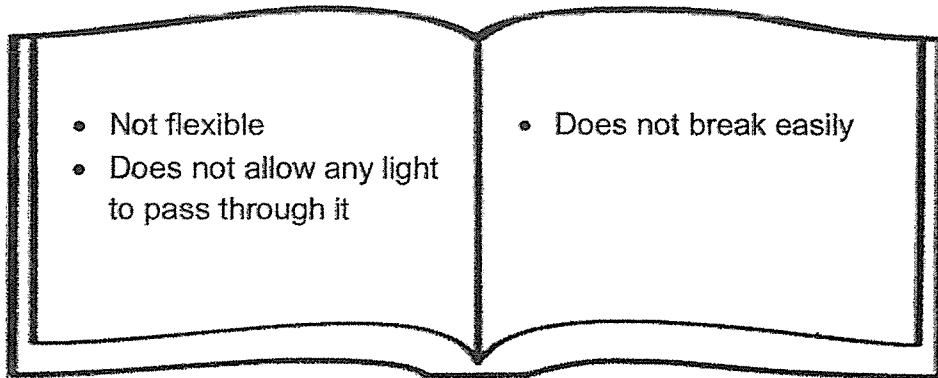

36. Linda wrote the following descriptions of object E in her Science journal.



(a) Based on the descriptions above, which object can object E be?

In the boxes provided, tick (✓) the correct answer.

[1]

Object	
 Marble	<input data-bbox="1077 1010 1152 1077" type="checkbox"/>
 Cotton blanket	<input data-bbox="1077 1234 1152 1301" type="checkbox"/>
 Styrofoam box	<input data-bbox="1077 1447 1152 1514" type="checkbox"/>
 Metal block	<input data-bbox="1077 1659 1152 1727" type="checkbox"/>

Continue on next page

Score	1
-------	---

Continued from previous page

- (b) Classify the four objects shown in part (a) into two groups based on the headings given in the table below. [1]

Waterproof	Not waterproof

- (c) When the four objects were dropped into a pail of water, which objects could Linda remove from the other objects most easily from the pail of water?

Explain your answer.

[1]

Score	
-------	---

37. The diagram below shows a syringe attached to a beaker that contains 70 cm^3 of water and 30 cm^3 of air.

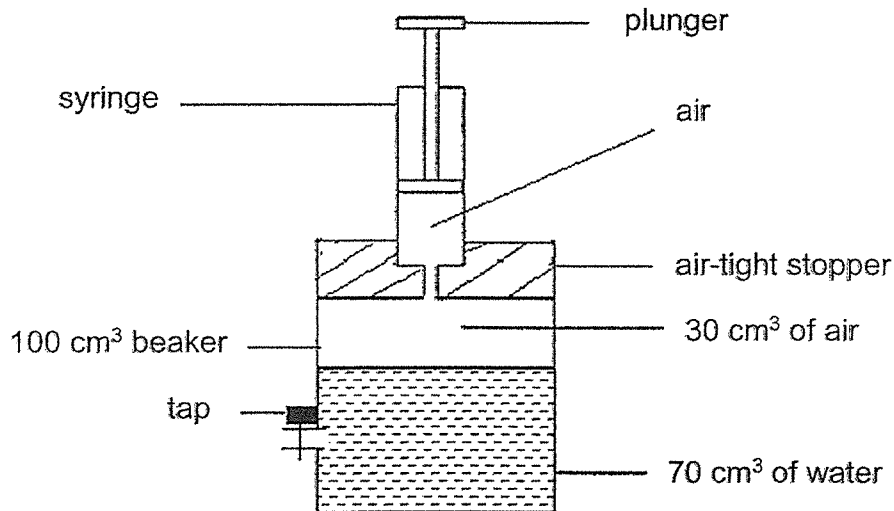

- (a) What would be the final volume of air in the beaker, after
- (i) 10 cm^3 of air has been pumped into the beaker? [1]
- _____ cm³
- (ii) 10 cm^3 of water has been removed from the beaker through the tap? [1]
- _____ cm³
- (b) Explain your answer for part (a)(ii). [1]

Continue on next page

Score	3
-------	---

Continued from previous page

(c) Another container is filled with water as shown below.

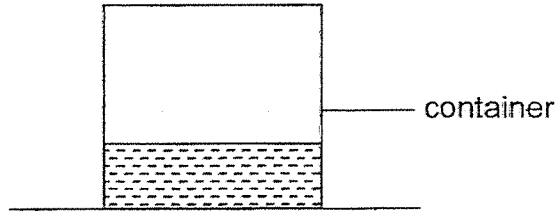

Which one of the diagrams below shows the water level correctly after the container is tilted?

Put a tick (✓) in the correct box below the diagram.

[1]

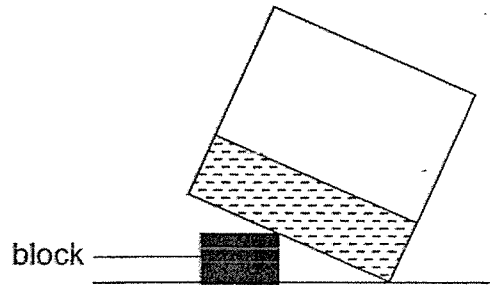
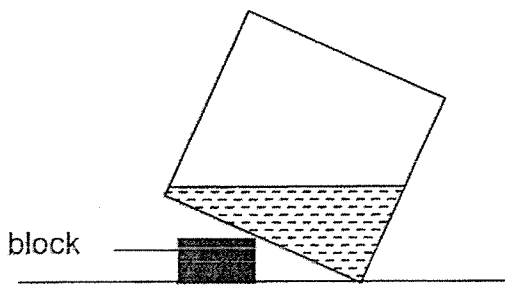

Score	1
-------	---

38. Elaine conducted the experiment shown below using a piece of plasticine and mould the entire piece into shape X and then into shape Y as shown in the diagrams below.

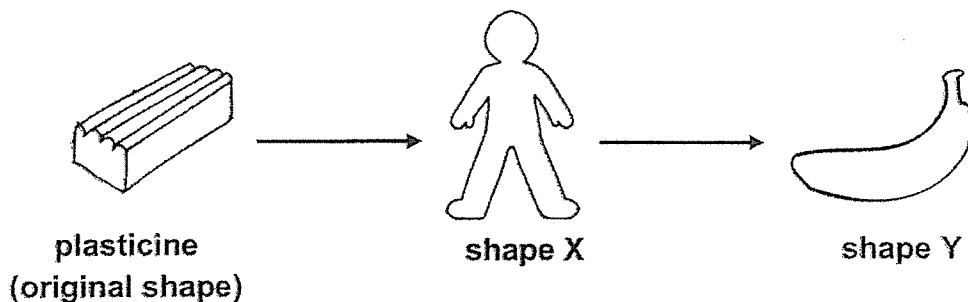

(a) She measured the mass of each shape every time she has formed it and record in the table below. Complete the table for the shapes X and Y below. [2]

Shape	Mass of the plasticine (g)
Start	500
X	
Y	

(b) Explain your answer for part (a). [1]

Score	3
-------	---

39. Peter was given a cylindrical container and a sponge as shown below. He tried to squeeze the whole sponge into the cylindrical container and was able to do so.

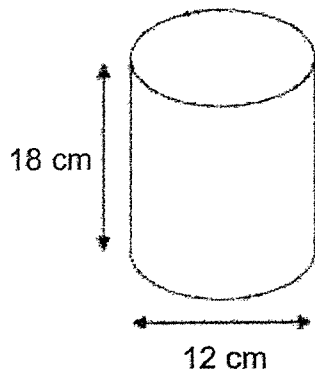

Cylindrical container

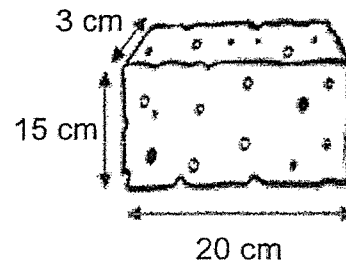

Sponge

- (a) What state of matter is the sponge? [1]

- (b) Peter was able to squeeze the sponge into the cylindrical container. Explain clearly why he was able to do so. [2]

Score	3
-------	---

40. Ken placed an inflated ball on an electronic balance as shown below. He observed that the mass of the inflated ball was 500 g.

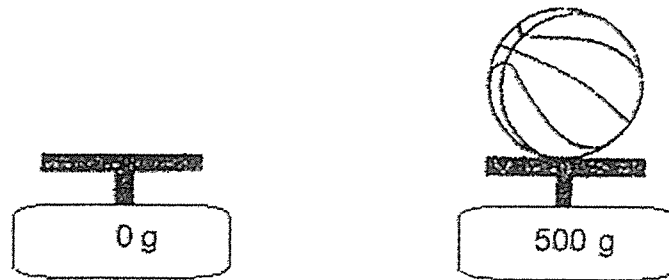

- (a) Ken deflated the ball and measured its mass. Would the mass of the basketball increase, decrease or remain the same? Explain your answer. [2]

- (b) The diagram below shows a syringe filled with air and water.

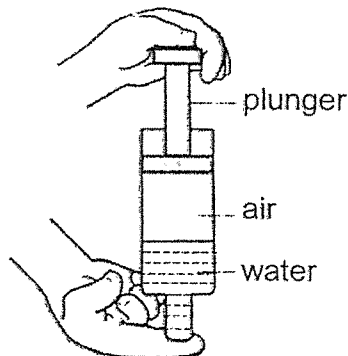

What would happen to the volume of air and volume of water in the syringe after the plunger was pushed in?

Put a tick (✓) in the correct boxes.

[2]

	Decreases	Increases	No change
Volume of air			
Volume of water			

Score	4
-------	---

41. Nishika hung four objects, A, B, C and D, on a wooden rod. The diagram shows her observations.

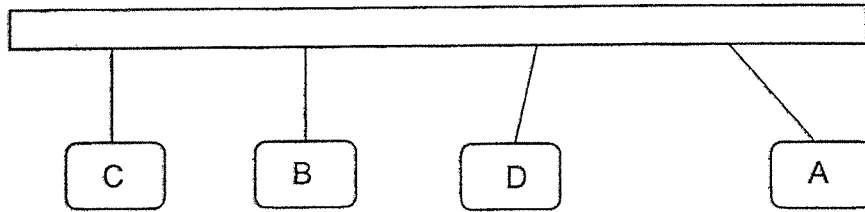

She then changed the positions of B and D. The diagram below shows her new observation.

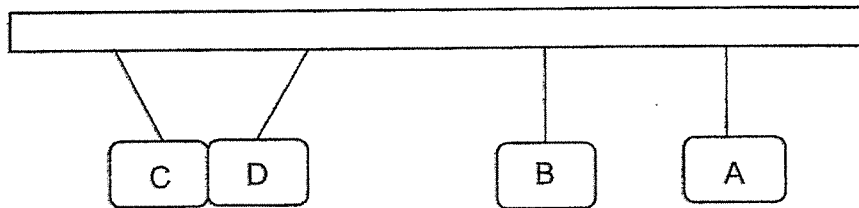

- (a) What material could object B most likely be made of? Explain your answer. [2]

- (b) Based on the information above, which objects are definitely magnets? Explain your answer. [2]

Score	4
-------	---

END OF PAPER

ANSWER KEY



YEAR : 2021
LEVEL : Primary 4
SCHOOL : Raffles Girls' Primary School
SUBJECT : SCIENCE
TERM : Mid-Year Examination

BOOKLET A

Q1	4	Q2	2	Q3	2	Q4	2	Q5	3
Q6	3	Q7	3	Q8	3	Q9	2	Q10	3
Q11	2	Q12	1	Q13	2	Q14	1	Q15	1
Q16	2	Q17	2	Q18	1	Q19	2	Q20	2
Q21	4	Q22	3	Q23	3	Q24	4	Q25	4
Q26	2	Q27	1	Q28	4				

BOOKLET B

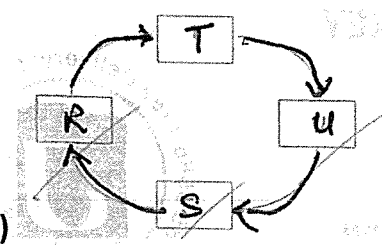
Q29	(a) Container C. Container C has air, food and water which is what living things need in order to survive. (b) No. The snails in container B has a lack of air and food, however container A had air but does not have food thus living longer due to sufficient air. (c) Yes. It has air food and water for itself. However, there is more than one snail in container C. Hence the food will run out easily and the snails in container C survives shorter than the snails in container D.
Q30	(a) Reptiles. (b) It has a body covering of hair and gives birth to its young alive. (c) Animal Z
Q31	(a) Difference 1 : The life cycle of a grasshopper has three stages but the life cycle of a butterfly has four stages. Difference 2 : The nymph of a grasshopper resembles its adult but the larva does not resemble its adult. (b) At the egg stage. It does not move around and eat anything. Hence, the egg stage would be the easiest for the farmer to get rid of the grasshoppers.

<p>Q32</p>	 <p>(a)</p> <p>(b) Stages U and S. It has its own true leaves to trap sunlight to make food for the plant.</p> <p>(c) The seed leaves will drop off.</p>								
<p>Q33</p>	<p>(a) (i) X : Stomach (ii) Y : small intestine</p> <p>(b) Water is removed from undigested food.</p>								
<p>Q34</p>	<p>(a) X: Circulatory Y: Respiratory</p> <p>(b) Skeletal system</p> <p>(c) It protects the heart and lungs.</p>								
<p>Q35</p>	<p>(a) The stem</p> <p>(b) It transports food from the leaves to all parts of the plant.</p> <p>(c) Part T of plant W is strong to support the plant but part T of plant Z is too weak to support the plant.</p> <p>(d) Part X can anchor the plant for firmly to the ground by growing deep into the ground.</p>								
<p>Q36</p>	<p>(a) Metal block</p> <p>(b)</p> <table border="1" data-bbox="303 1232 1404 1411"> <thead> <tr> <th>Waterproof</th> <th>Not waterproof</th> </tr> </thead> <tbody> <tr> <td>Marble marble</td> <td>Cotton Blanket</td> </tr> <tr> <td>Styrofoam</td> <td></td> </tr> <tr> <td>Metal block</td> <td></td> </tr> </tbody> </table> <p>(c) Styrofoam box. It floats on water while the metal block ,marble and cotton blanket sinks in water.Hence, the styrofoam box could be removed from the other objects most easily from the pail of water.</p>	Waterproof	Not waterproof	Marble marble	Cotton Blanket	Styrofoam		Metal block	
Waterproof	Not waterproof								
Marble marble	Cotton Blanket								
Styrofoam									
Metal block									
<p>Q37</p>	<p>(a)(i) 30cm^3 (ii) 40cm^3</p> <p>(b) When water is removed, the amount of space left will increase.Air has no definite volume. Hence , the air will take up the space left in the beaker which is 40cm^3.</p>  <p>(c) <input checked="" type="checkbox"/> <input type="checkbox"/></p>								
<p>Q38</p>	<p>(a)</p> <table border="1" data-bbox="303 1971 742 2049"> <tbody> <tr> <td>X</td> <td>500</td> </tr> <tr> <td>Y</td> <td>500</td> </tr> </tbody> </table>	X	500	Y	500				
X	500								
Y	500								

	(b) The plasticine is solid and has a definite mass. Hence, whatever shape she makes, the mass would remain the same.
Q39	(a) Solid. (b) There were air spaces inside the sponge. When he squeezes the sponge, the air escapes. Hence, Peter will be able to squeeze the sponge into the cylindrical container.
Q40	(a) Decrease. There was air in the ball occupying space and air has mass. Thus, when the basketball deflates, the mass will decrease. (b) Volume of air : Decreases Volume of water : No change
Q41	(a) A non-magnetic material. When A is placed beside D, both rods repel, which means that A and D are magnets. However when A is placed beside B, there was no reaction. Hence, B is made of a non magnetic material. (b) A and D. When they are placed beside each other, they repel each other, hence, A and D are magnets.

