

CATHOLIC HIGH SCHOOL
MID-YEAR EXAMINATION (2021)
PRIMARY FOUR
SCIENCE
BOOKLET A

Name: _____ ()

Class: Primary 4 - _____

Date: 11 May 2021

24 questions

48 marks

Total Time for Booklets A and B: 1 hour 30 minutes

INSTRUCTIONS TO CANDIDATES

Do not turn over this page until you are told to do so.

Follow all instructions carefully.

Answer all questions.

Shade your answers in the Optical Answer Sheet (OAS) provided.

This booklet consists of 16 printed pages, excluding the cover page.

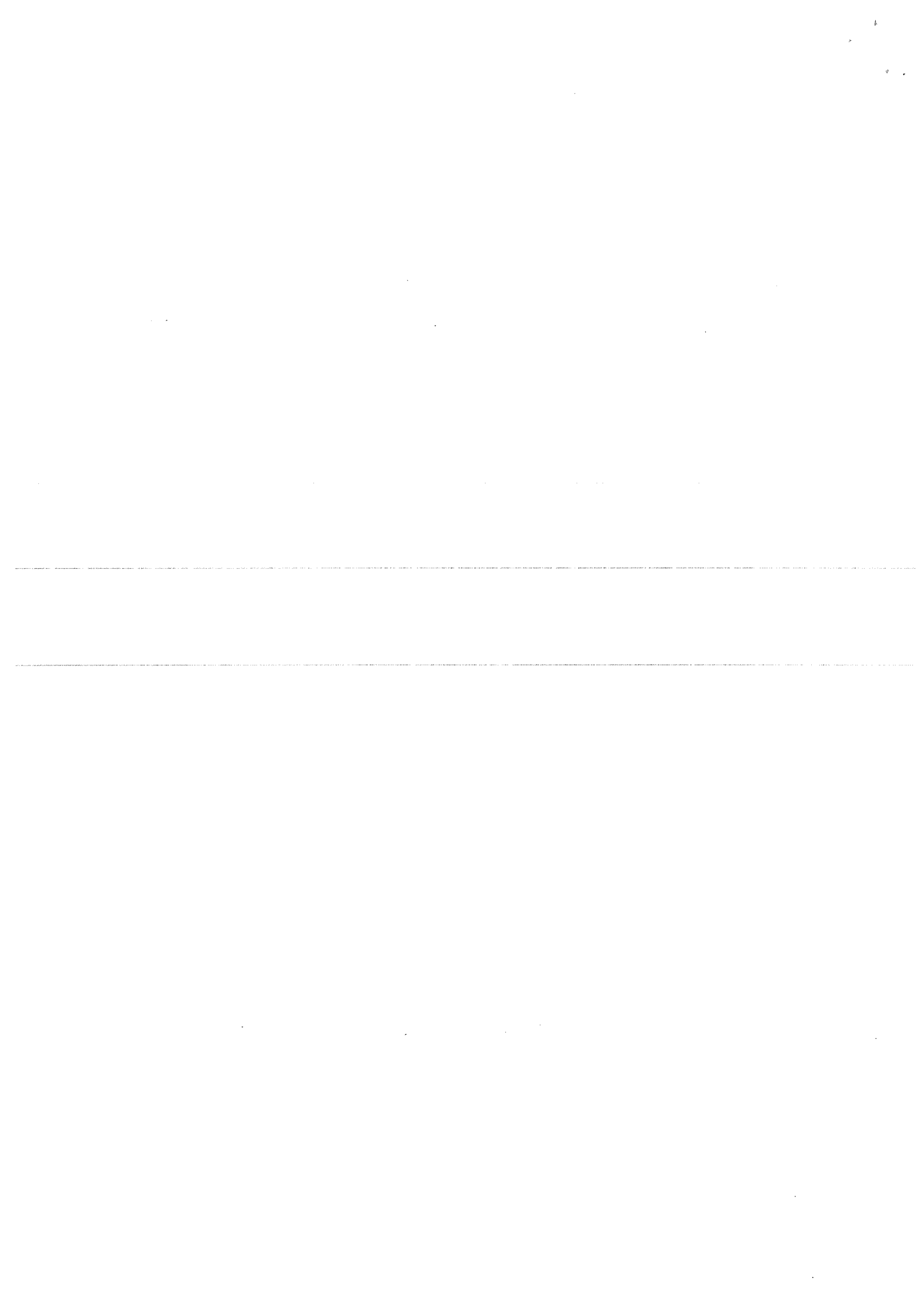

Booklet A (24 × 2 marks)

For each question from 1 to 24, four options are given. One of them is the correct answer. Make your choice (1, 2, 3 or 4). Shade your answer on the Optical Answer Sheet. (48 marks)

- 1 The table below shows the characteristics of four things, A, B, C and D. A tick (✓) indicates the presence of the characteristic.

Thing	Needs air, food and water	Can make food	Has four legs
A	✓		✓
B			✓
C	✓		
D	✓	✓	

Which of the following correctly represents A, B, C and D?

	A	B	C	D
(1)	mosquito	rose plant	table	lion
(2)	lion	table	rose plant	mosquito
(3)	table	mosquito	lion	rose plant
(4)	lion	table	mosquito	rose plant

2 Study the diagram below.

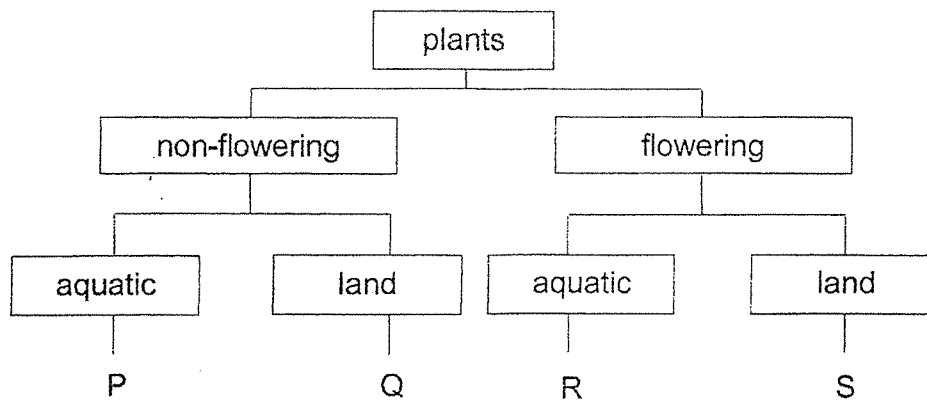

Plant E reproduces from spores and grows on the branches of a tall tree.

Based on the characteristics of plant E, which letter, P, Q, R or S, represents plant E?

- (1) P
- (2) Q
- (3) R
- (4) S

3 Three pupils made the following statements about bacteria.

Alice Bacteria cannot make its own food.
John Bacteria can be useful or harmful to living things.
Peter Bacteria can only feed on living things that are alive.

Which pupil(s) was/were correct?

- (1) Alice only
- (2) Peter only
- (3) Alice and John only
- (4) John and Peter only

4 Study the diagram below.

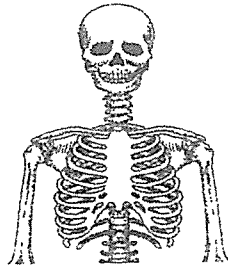

Which of the following is **not** a function of the system above?

- (1) supports the body
 - (2) gives the body its shape
 - (3) removes air from the body
 - (4) protects the organs in the body
- 5 Which of the following helps to hold the plant upright?

- (1) leaf
- (2) root
- (3) fruit
- (4) stem

6 Ravi kept four mealworms, J, K, L and M, each at a different stage of growth, in four containers. He placed 12 g of food in each container and recorded the amount of food left in the containers after three days as shown in the table below.

Mealworms in container	Amount of food left after 3 days (g)
J	4
K	8
L	10
M	12

Which mealworm is most likely to be in the pupa stage?

- (1) mealworm J
- (2) mealworm K
- (3) mealworm L
- (4) mealworm M

- 7 Muthu did a study on two animals, P and Q, and recorded his observations as shown below.

Observations	Animal P	Animal Q
It has six legs.	✓	✓
Eggs are laid on land.	✓	
It has a 4-stage life cycle.		✓

Which of the following represents animals P and Q?

	Animal P	Animal Q
(1)	butterfly	frog
(2)	grasshopper	mosquito
(3)	grasshopper	frog
(4)	butterfly	mosquito

- 8 The graph below shows the duration of the four stages of the life cycles of insects A and B.

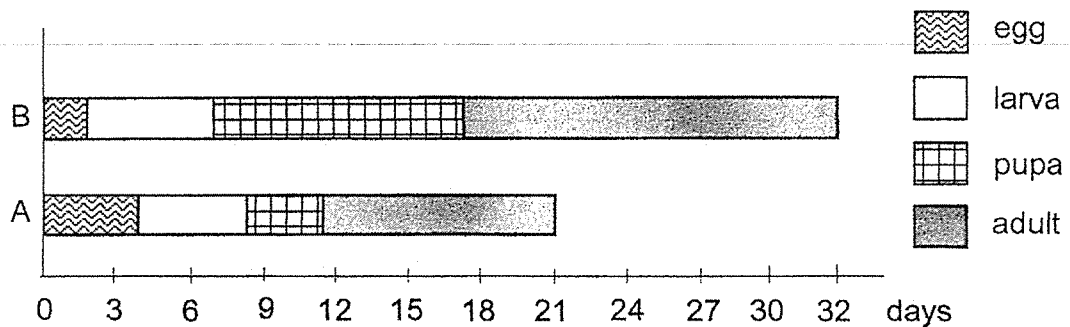

On which day are the insects at the same stage in their life cycle if the eggs are laid on the same day?

- (1) Day 3
- (2) Day 6
- (3) Day 13
- (4) Day 16

9 Chitra planted a bean seed and wrote a journal about the growth of her bean plant. However, she did not record the growth of the bean plant correctly.

- A The shoot appears.
- B A root grows downwards.
- C Two green leaves appear.
- D The flowers develop into fruits.
- E The seeds will grow into new plants.

Which of the following shows the correct order of the growth?

- (1) A → C → E → D → B
- (2) B → A → C → D → E
- (3) B → C → A → D → E
- (4) C → A → B → E → D

- 10 Cai Ling wanted to find out if temperature affects the growth of bean seeds. Four similar set-ups were placed at different places as shown below.

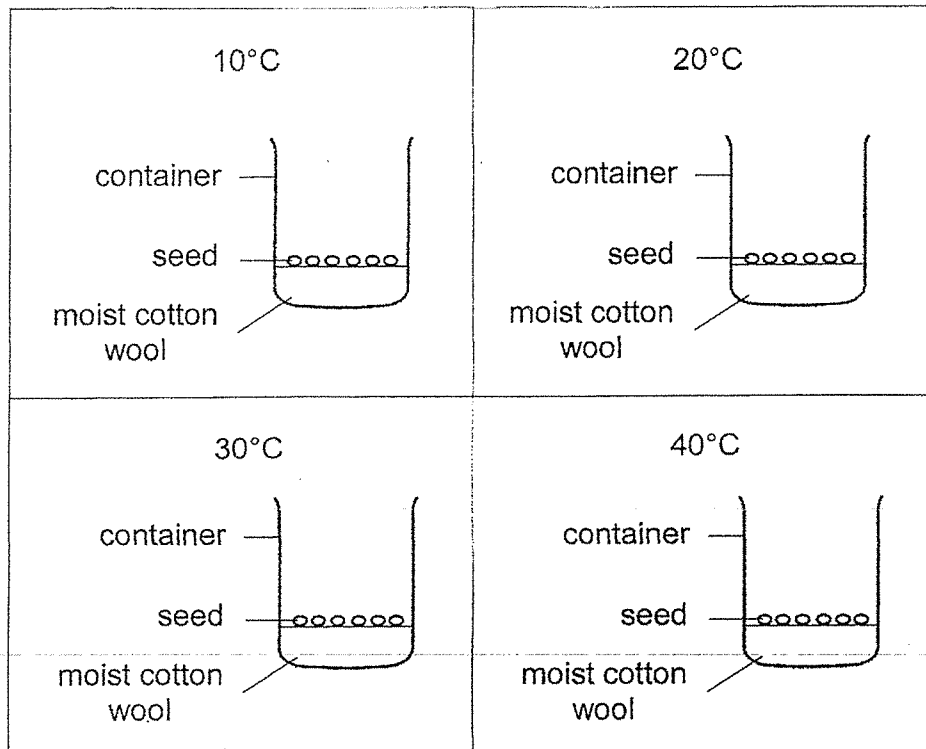

After four days, she counted the number of seeds that grew and recorded her results as shown below.

Temperature (°C)	Number of seeds grown
10	0
20	2
30	6
40	4

What could Cai Ling conclude from the results above?

- (1) Bean seeds could not grow below 40°C.
- (2) Bean seeds could grow at any temperature.
- (3) The best temperature for bean seeds to grow was 30°C.
- (4) The number of seeds grown increased as the temperature increased.

- 11 En Jie set up an experiment as shown below to compare a property of four strips, P, Q, R and S, which are made of different materials.

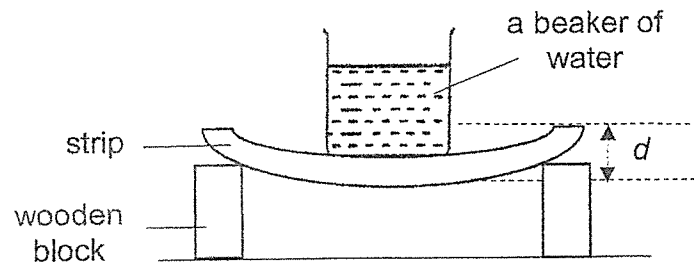

En Jie placed a beaker holding 100 ml of water on each strip and measured the distance, d . His results are as shown below.

Strip	Amount of water in the beaker (ml)	d (cm)
P	100	2
Q	100	3
R	100	5
S	100	7

Based on En Jie's experiment, which strip is most suitable for making a food tray as shown below?



- (1) P
- (2) Q
- (3) R
- (4) S

- 12 Jasmine lowered a bar magnet into a tray of iron pins as shown in the diagram below.

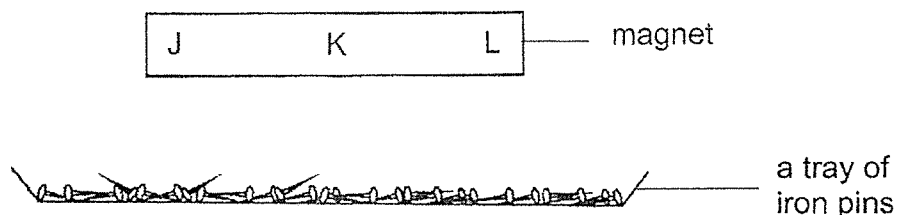

Which of the following correctly represents the number of iron pins attracted by each part of the bar magnet?

Number of iron pins attracted			
	J	K	L
(1)	9	2	8
(2)	8	7	6
(3)	5	6	9
(4)	9	2	2

- 13 Objects A and B of the same size were pulled towards magnet X as shown in the diagram below.

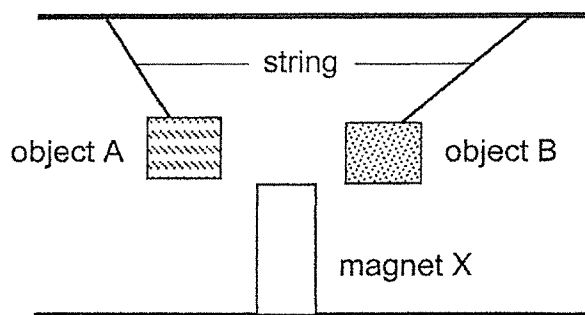

Based on the observations above, which statement about objects A and B is correct?

- (1) Object A is a magnet but object B is non-magnetic.
- (2) Object B is a magnet but object A is non-magnetic.
- (3) Both objects A and B are made of magnetic materials.
- (4) Object A is made of iron and object B is made of copper.

14 Aishah stroked an iron bar with a magnet as shown below.

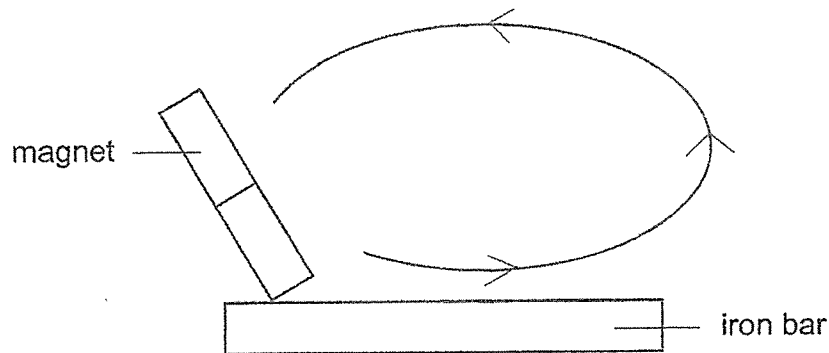

The iron bar attracted one paper clip after it was stroked a few times.

What could Aishah do so that the iron bar could attract more than one paper clip?

- (1) Drop the iron bar a few times.
- (2) Heat the iron bar over a flame.
- (3) Stroke the iron bar in different directions many times.
- (4) Increase the number of strokes on the iron bar in the same direction.

15 Below are some statements made about matter.

- A Matter has mass.
- B Matter can be seen.
- C Matter occupies space.
- D Matter has a definite shape.

Which statements about matter are correct?

- (1) A and B only
- (2) A and C only
- (3) C and D only
- (4) B, C and D only

16 The table below shows the mass of three objects.

Object	Mass (g)
P	85
Q	135
R	205

Which diagram is correct?

(1)

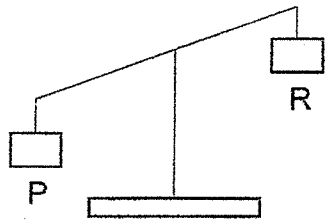

(2)

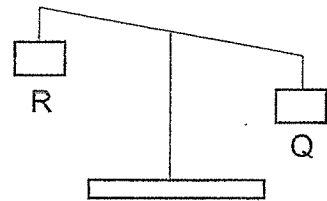

(3)

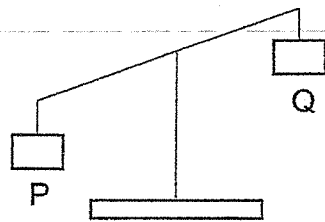

(4)

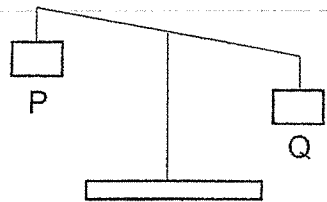

- 17 Siva filled a cylinder with 5 cm³ of water and sealed it with a plunger as shown below.

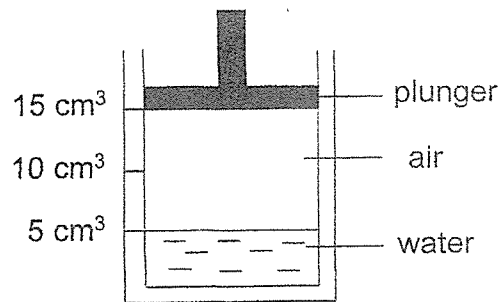

What would Siva see after he pushed the plunger downwards as far as he could without any air or water escaping?

(1)

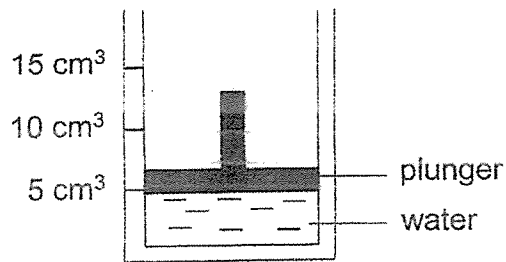

(2)

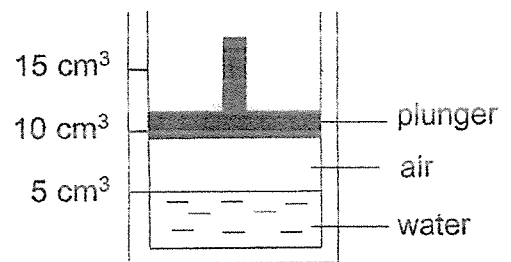

(3)

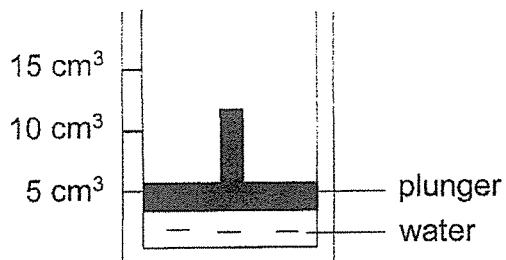

(4)

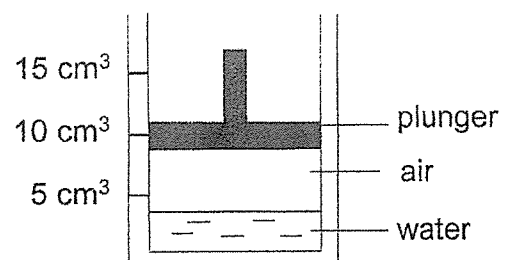

18 Three identical glasses contained the following matter.

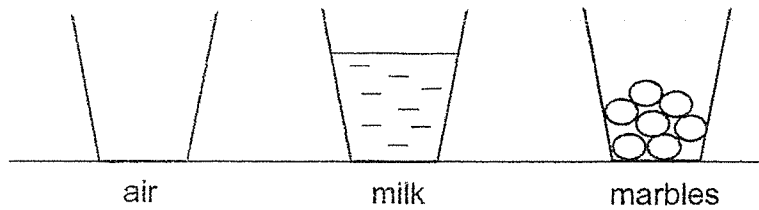

A jug of water was poured into each glass at the same time.

In what order, from the first to the last, would the water overflow?

	first	last
(1)	air	milk
(2)	marbles	air
(3)	milk	marbles
(4)	marbles	air

19 Study the diagram below.

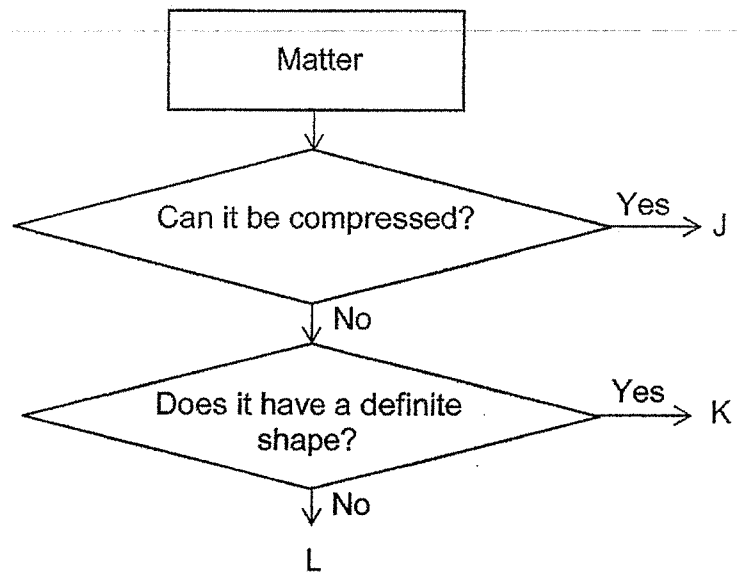

Which of the following correctly represents J, K and L?

	J	K	L
(1)	water	water vapour	ice cube
(2)	water vapour	ice cube	water
(3)	ice cube	water	water vapour
(4)	water vapour	water	ice cube

- 20 Joe recorded the volume and mass of three balls that are made of different materials as shown below.

Ball	Volume	Mass
A	50 cm ³	500 g
B	150 cm ³	300 g
C	200 cm ³	300 g

He then made some statements below.

- A Objects of a smaller volume occupies less space.
- B Objects of a different volume can have the same mass.
- C An object that occupies less space is lighter than an object that occupies more space.

Based on the information above, which statements are correct?

- (1) A and B only
- (2) A and C only
- (3) B and C only
- (4) A, B and C

- 21 Study the things below.

- A sun
- B earth
- C mirror
- D candle flame

Which are **not** sources of light?

- (1) A and B
- (2) A and D
- (3) B and C
- (4) C and D

22 Which diagram correctly shows the path of light that enables Yi En to see the object?

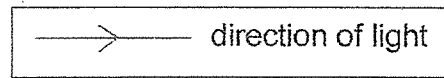

(1)

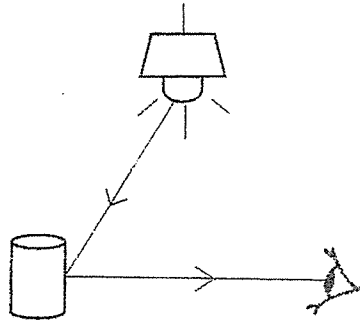

(2)

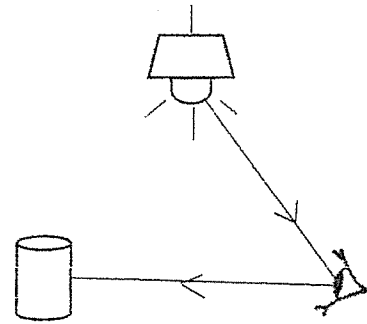

(3)

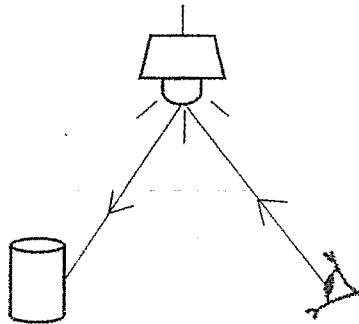

(4)

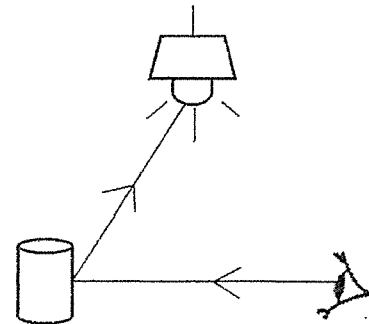

- 23 The diagram below shows the top view of a road. Mirrors were placed at some corners of the road for the purpose of road safety.

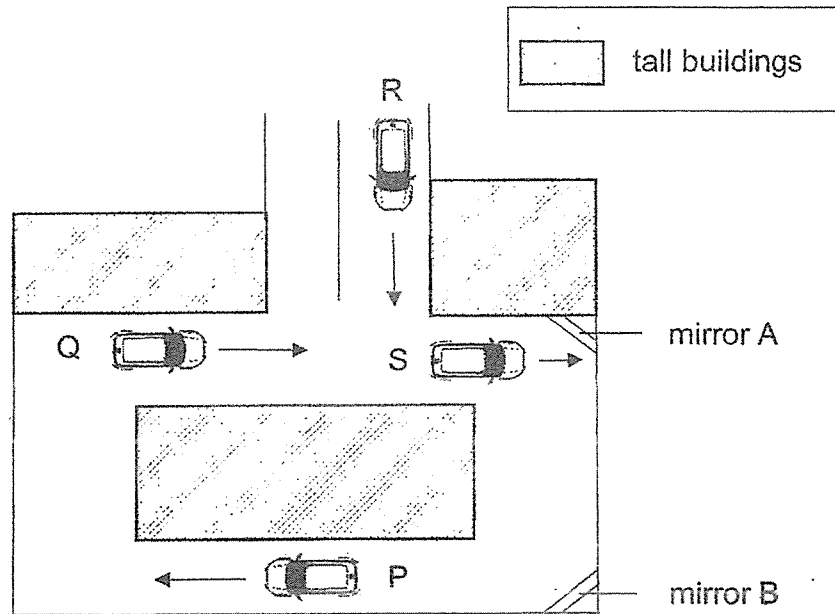

Using mirrors A and B only, which statement is correct?

- (1) The driver in car S can see car R.
- (2) The driver in car R can see car Q.
- (3) The driver in car P can see car Q.
- (4) The driver in car S can see car P.

- 24 Ahmad had four sheets of materials, P, Q, R and S. The sheets were of the same size. He arranged the sheets in a straight line in a completely dark room. When the torch was switched on, he could see a bright spot on sheet R only.

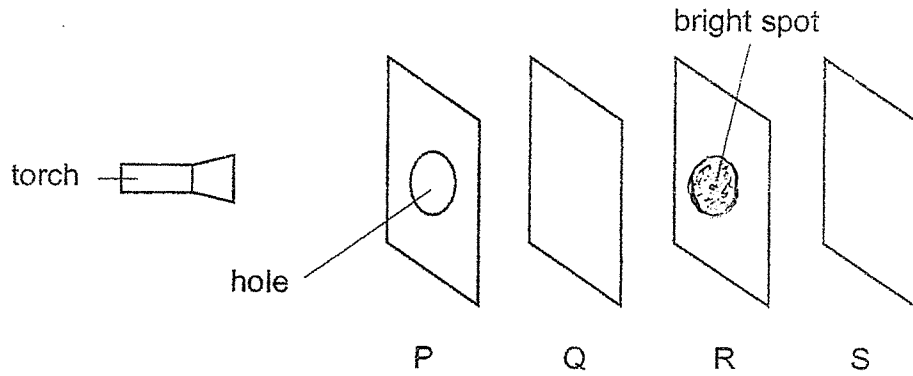

Which of the following about the four sheets of materials is correct?

	Does not allow light to pass through	Allow the most light to pass through	Not possible to tell
(1)	R, P	Q	S
(2)	S	P and Q	R
(3)	P	R	Q and S
(4)	R and S	P	Q

End of Booklet A

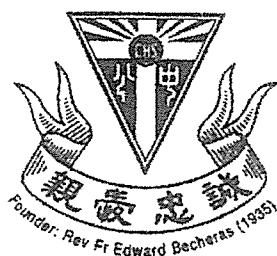

CATHOLIC HIGH SCHOOL
MID-YEAR EXAMINATION (2021)
PRIMARY FOUR
SCIENCE
BOOKLET B

Name: _____ ()

Class: Primary 4 - _____

Date: 11 May 2021

Parent's Signature: _____

Booklet A	48
Booklet B	32
Total	80

10 questions

32 marks

Total Time for Booklets A and B: 1 hour 30 minutes

INSTRUCTIONS TO CANDIDATES

Do not turn over this page until you are told to do so.

Follow all instructions carefully.

Answer all questions.

Write your answers in this booklet.

This booklet consists of 14 printed pages, excluding the cover page.

Booklet B (32 marks)

For questions 25 to 35, write your answers in this booklet.

The number of marks available is shown in brackets [] at the end of each question or part question. (32 marks)

25 Study the diagram below.

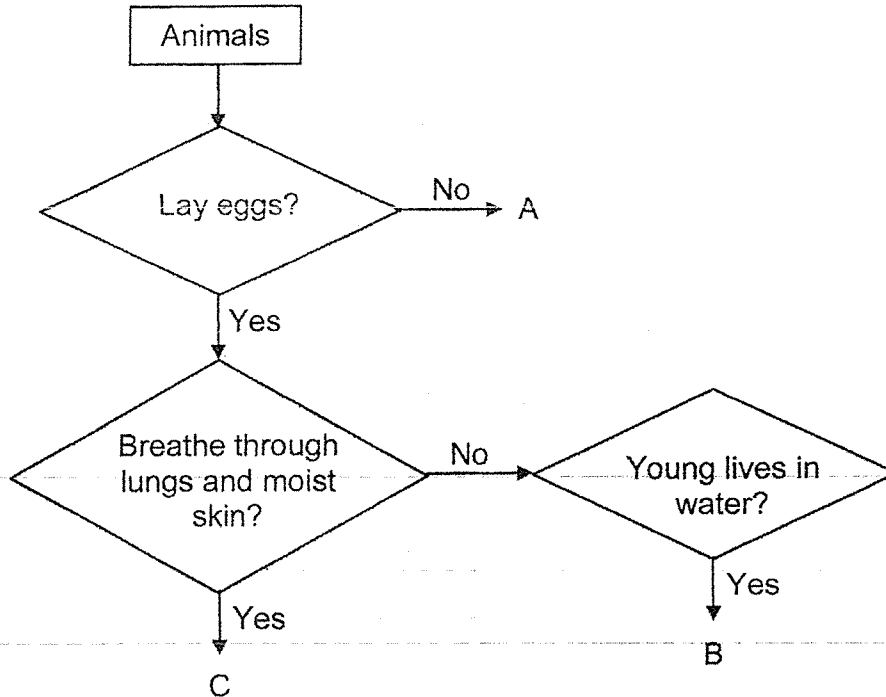

(a) Which letter, A, B or C, represents a whale? [1]

(b) State one similarity between animals B and C. [1]

(Go on to the next page)

SCORE	2
-------	---

26 The diagram below shows the human digestive system.

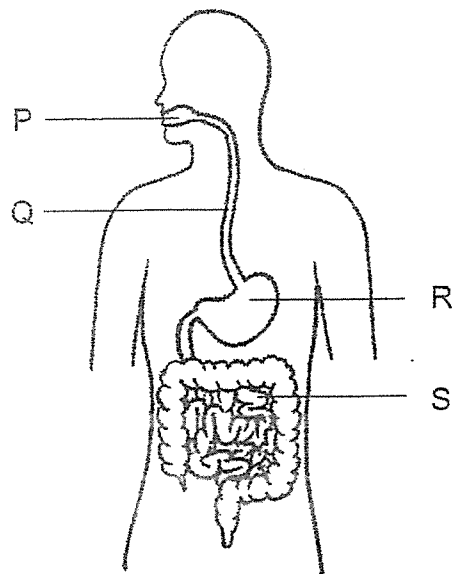

(a) Name organs Q and R. [1]

Organ Q: _____

Organ R: _____

(b) Which organ(s), P, Q, R or S, do/does digestion of food take place? [1]

(c) What happens to the digested food in organ S? [1]

(Go on to the next page)

SCORE	3
-------	---

27 Study the diagram below.

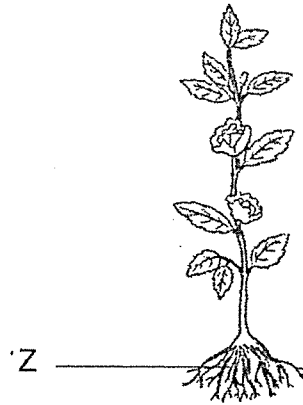

(a) State one function of part Z.

[1]

(b) Devak wanted to find out if the number of leaves affects the growth of a plant. He then carried out the experiment as shown below.

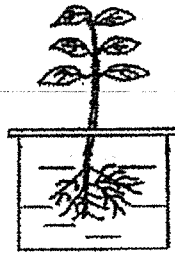

Set-up A

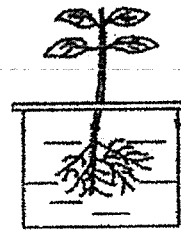

Set-up B

Put a tick (✓) in the box(es) next to the variable that Devak must keep the same to make his test fair.

[1]

Variables	Tick (✓)
type of plant	
number of leaves	
amount of water left after a few days	
location where the experiment took place	

(Go on to the next page)

SCORE	2
-------	---

28 Study the diagram below.

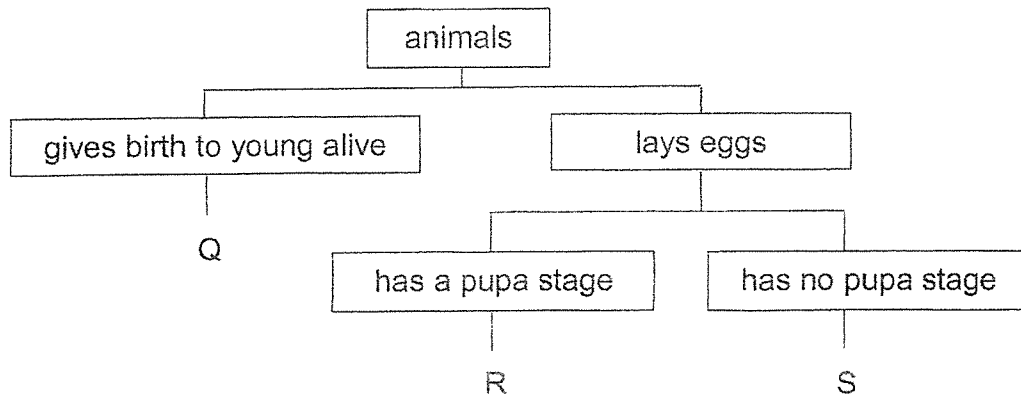

(a) Which animal, Q, R or S, is most likely to have a young that does not look like its parent? [1]

(b) Draw the life cycle of an insect that has the same characteristics as animal S. [2]

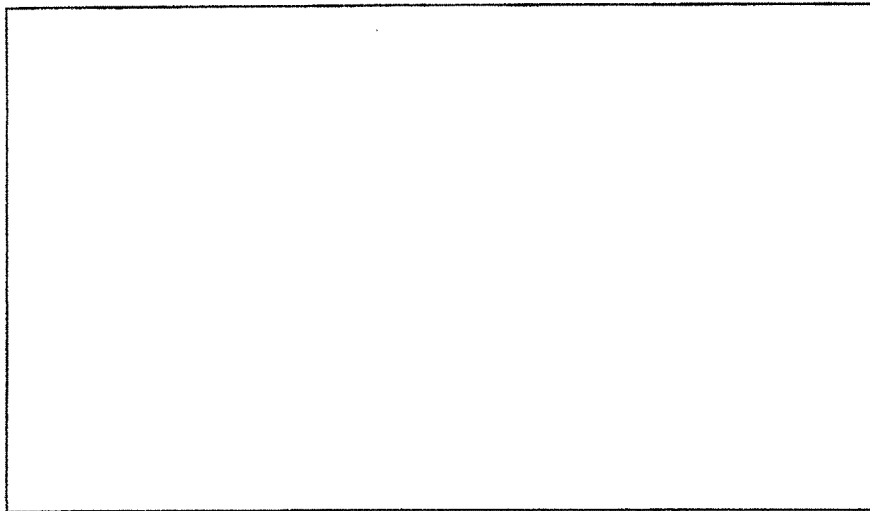

(Go on to the next page)

SCORE	3
-------	---

- 29 Junjie planted some beans and observed the growth of the beans. He recorded the mass of the seed leaves in the table shown below.

Number of days	3	5	7	9
Average mass of seed leaves (g)	4	3	2	0

- (a) Based on the results above, what is the relationship between the number of days and the average mass of the seed leaves? [1]

- (b) How did the seedling get its food for growth after Day 9? [1]

(Go on to the next page)

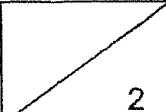
SCORE	
-------	---------------------------------------------------------------------------------------

- 30 Four identical sheets, A, B, C and D, of different materials were used for this experiment. The table below shows the mass of these sheets before and after they were put into four beakers, each containing an equal amount of water.

Material	Mass before putting into water (g)	Mass after putting into water (g)
A	7	10
B	10	13
C	11	16
D	13	13

- (a) What property of the material is the experiment testing? [1]

The diagram below shows a pair of gloves that helps to keep a person's hands dry when doing some chores.

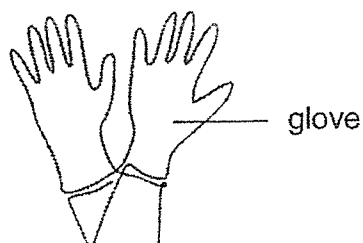

- (b) Based on the results in the table above, which material would you use to make the glove? Explain why. [2]

(Go on to the next page)

SCORE	3
-------	---

- 31 Norimah brought two bar magnets near each other. She observed that they moved in the directions as shown by the arrows.

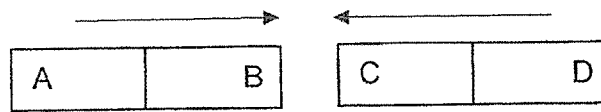

- (a) Name the poles at B and C. [1]

B: _____

C: _____

- (b) Explain your answer in (a). [1]

She then set up an experiment as shown below.

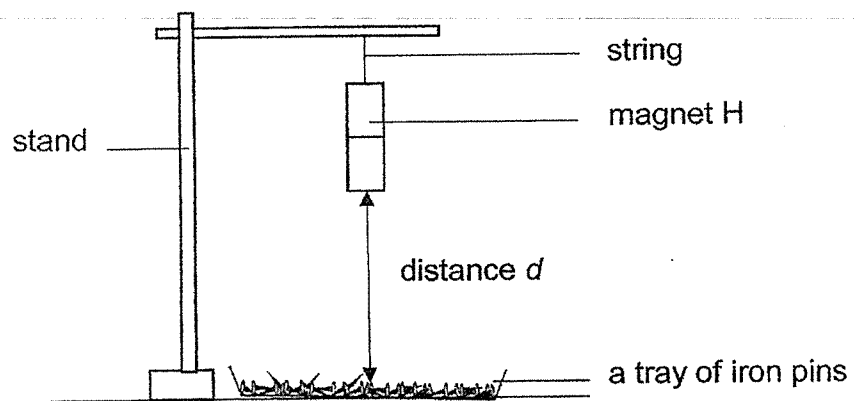

She hung magnet H at different distances, d , from the tray of iron pins and recorded the number of iron pins attracted.

(Go on to the next page)

SCORE	2
-------	---

Continue from Question 31

The table below shows her results.

Distance d (cm)	2	4	6	8
Number of iron pins attracted	15	12	8	5

- (c) Based on the results above, what is the relationship between distance d and the number of iron pins attracted by magnet H? [1]

- (d) Norimah decided to change the tray of iron pins to copper pins. She noticed that magnet H did not attract any copper pins. Explain why. [1]

(Go on to the next page)

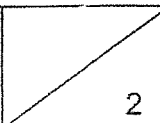
SCORE	
-------	---------------------------------------------------------------------------------------

- 32 Si Qin wanted to make an electromagnet using the electrical method as shown in the set-up below.

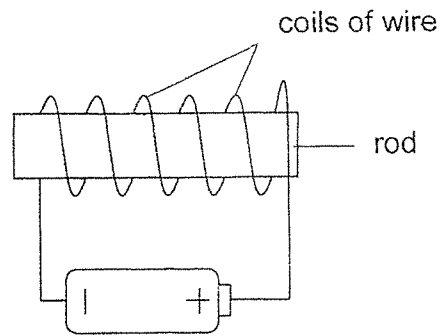

- (a) Name a suitable material for the rod.

[1]

After Si Qin had constructed the electromagnet, she tested it. She observed that the electromagnet could only attract 4 steel clips.

She reconstructed her electromagnet. This time, it could attract 8 steel clips.

- (b) Without replacing or adding any of the items found in the set-up above, suggest what she had done to the electromagnet in order to attract 8 steel clips.

[1]

- (c) What would Si Qin observe after removing the battery from the set-up?

[1]

(Go on to the next page)

SCORE	3
-------	---

- 33 Krishna filled a container with some water. An empty inverted plastic cup was pushed into the container of water as shown in the set-up below.

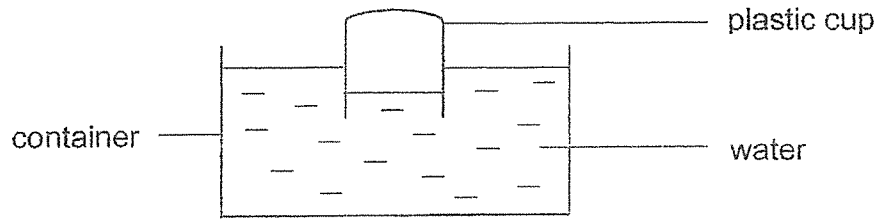

- (a) Explain why only some water was able to enter the plastic cup. [2]

Krishna then made a hole at the bottom of the plastic cup and pushed the cup into the container of water again.

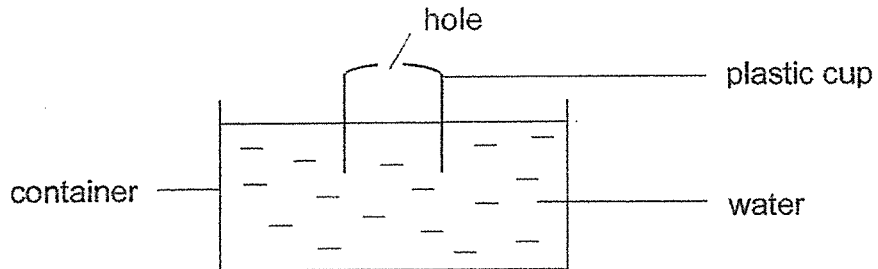

- (b) She observed that more water could enter the plastic cup. Explain why. [1]

(Go on to the next page)

SCORE	3
-------	---

- 34 Jake filled a syringe with 10 cm^3 of air and 10 ml of water as shown in the diagram below. He sealed the end of the syringe and pushed in the plunger till it could not be pushed any further.

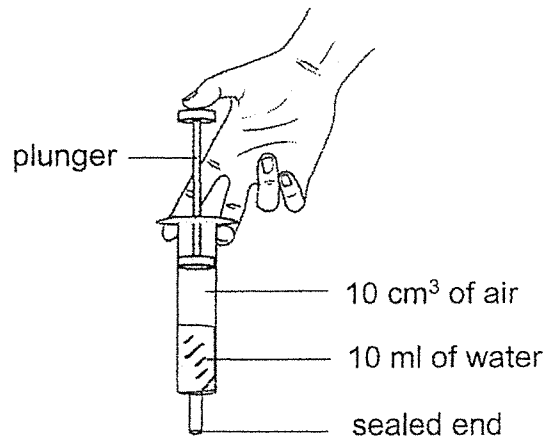

- (a) From the diagram above, what happened to the volume of air and water in the syringe? Put a tick (\checkmark) in the table below. [1]

		Increased	Decreased	Remained the same
(i)	Volume of air			
(ii)	Volume of water			

- (b) Explain your answer in (a) (ii). [1]

(Go on to the next page)

SCORE	2
-------	---

Continue from Question 34

Jake then pumped 10 cm^3 of air into a flask that has a capacity of 100 cm^3 as shown below.

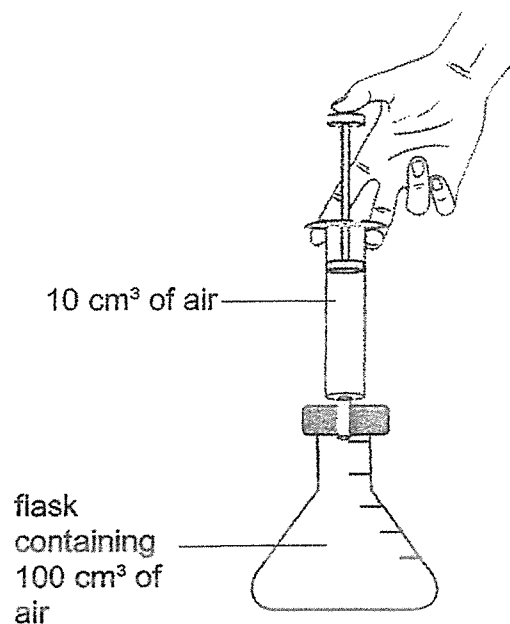

- (c) What would be the final volume of air in the flask? Give a reason for your answer. [1]

(Go on to the next page)

SCORE	1
-------	---

- 35 Mary wanted to find out which material, X, Y or Z, allowed the most light to pass through. In a completely dark room, material X was first placed in between a torch and a light sensor, connected to a datalogger as shown in the diagram below. Then, she repeated the experiment with materials Y and Z.

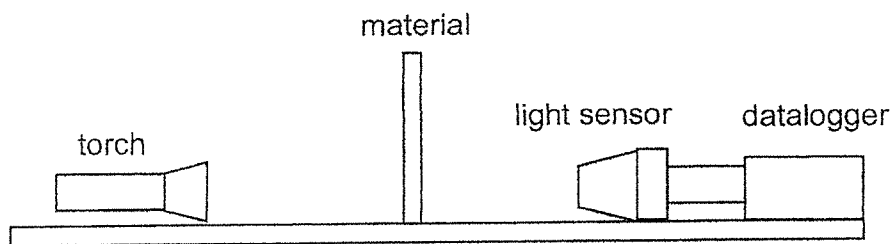

The table below shows the results of her experiment.

Materials	Amount of light detected by light sensor (units)
X	150
Y	0
Z	230

- (a) Put a tick (✓) in the box next to the changed variable in this experiment. [1]

Variables	Tick (✓)
type of material	
amount of light detected	
distance between the torch and material	

- (b) Based on the above results, what can you conclude about material Y? [1]

(Go on to the next page)

SCORE	2
-------	---

Continue from Question 35

Study the diagram below.

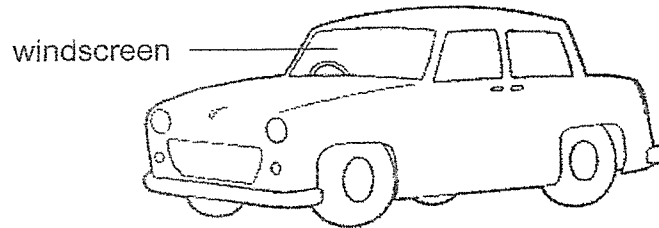

- (c) Based on Mary's observation, which material is the most suitable for making the windscreen of a car? Explain your answer. [2]

End of Booklet B

SCORE	2
-------	---

ANSWER KEY

YEAR : 2021
LEVEL : Primary 4
SCHOOL : Catholic High School
SUBJECT : SCIENCE
TERM : Mid-Year Examination

BOOKLET A

Q1	4	Q2	2	Q3	3	Q4	3	Q5	4
Q6	4	Q7	2	Q8	2	Q9	2	Q10	3
Q11	1	Q12	1	Q13	3	Q14	4	Q15	2
Q16	4	Q17	2	Q18	3	Q19	2	Q20	1
Q21	3	Q22	1	Q23	4	Q24	1		

BOOKLET B

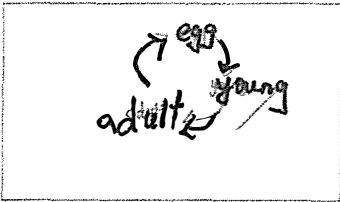
Q25	(a) A (b) Both B and C lays eggs.
Q26	(a) Organ Q : gullet Organ R : stomach (b) P,R,S (c) Digested food is absorbed into the bloodstream.
Q27	(a) The roots absorb water and mineral salts. (b) Type of plant, location where the experiment took place
Q28	(a) R  (b)
Q29	(a) As the number of days increases, the average mass of the seed leaves decreases. (b) The seedling has leaves to make food for itself.
Q30	(a) It is waterproof (b) Material D, as it has the same mass before and after being in water, thus it is waterproof.
Q31	(a) B: North C: South (b) Unlike poles of magnets attract each other, thus since B and C are

	<p>attracting each other, it should be unlike poles facing each other.</p> <p>(c) As distance d increases, the number of iron pins attracted by the magnet decreases.</p> <p>(d) Copper is a non-magnetic material and since magnet only can attract magnetic material, copper would not be attracted.</p>
Q32	<p>(a) Iron rod</p> <p>(b) She increased the coils of wire around the iron rod.</p> <p>(c) The iron rod would not attract any paper clip.</p>
Q33	<p>(a) Air was trapped in the plastic cup and it occupies space , and air can be compressed so only some water could enter the cup.</p> <p>(b) Air escaped through the hole in the cup so more water could enter to occupy the space previously occupied by the air.</p>
Q34	<p>(a)(i) Decreased</p> <p>(ii) Remained the same</p> <p>(b) Water has a definite volume of water.</p> <p>(c) 100cm^3. As air does not have a definite volume, and occupies all available space.</p>
Q35	<p>(a) type of material</p> <p>(b) Material Y do not allow light to pass through.</p> <p>(c) Material Z, Z allows the most amount of light to pass through so it allows the driver to see the road most clearly when he is driving.</p>